

REVISIONS				
P	LTN	DESCRIPTION	DATE	OWN APVD
-	SEE SHEET 1			

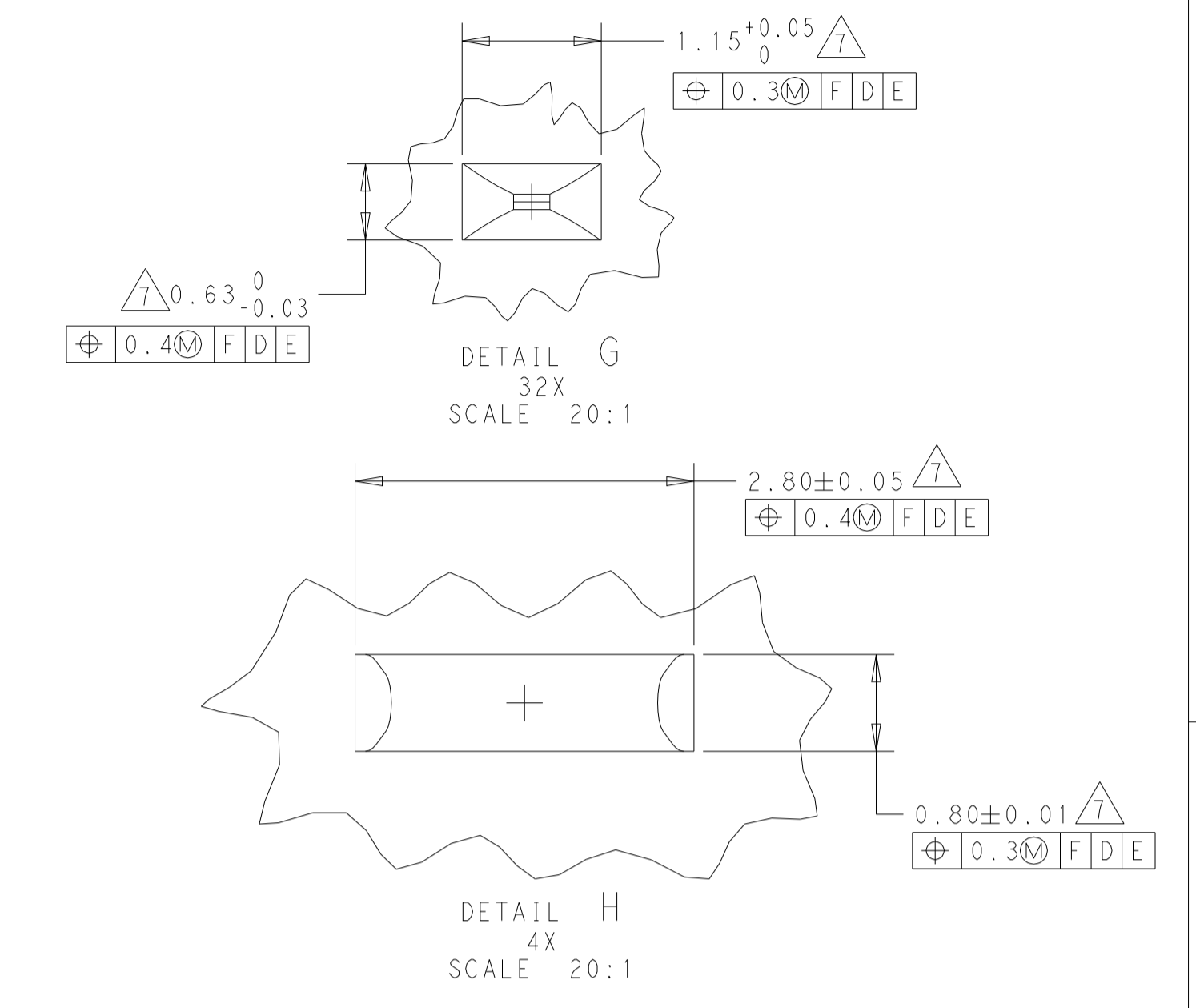
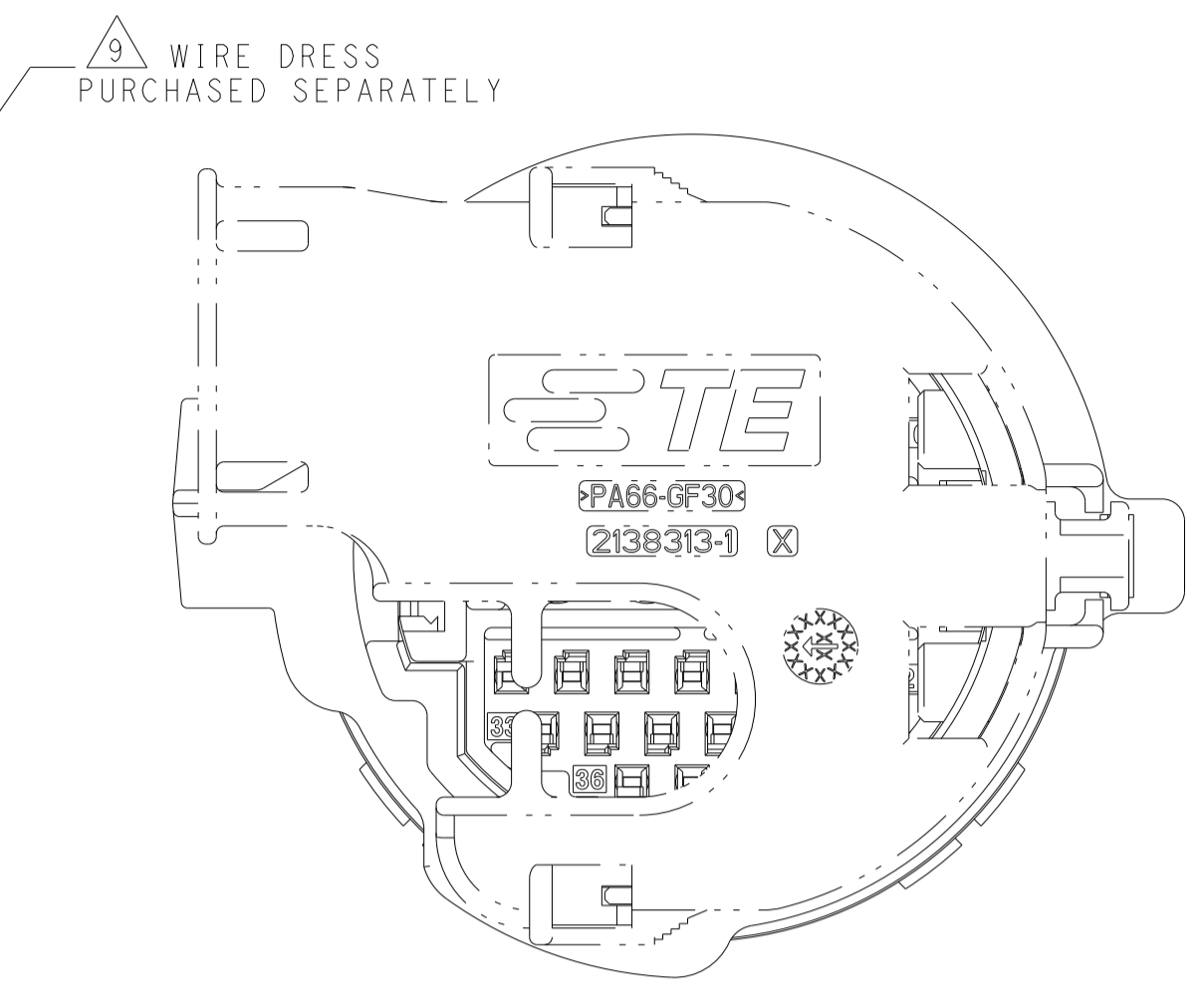
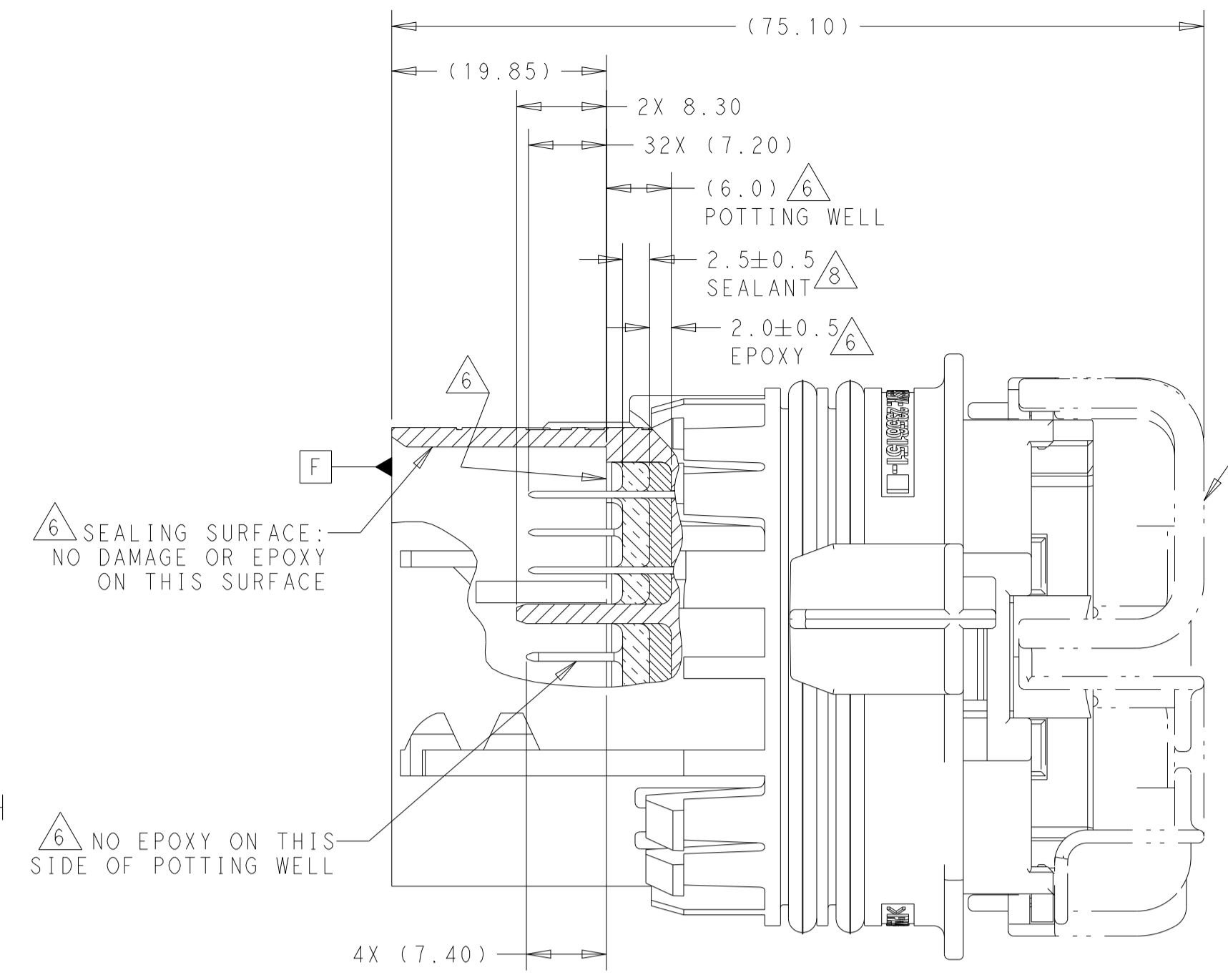
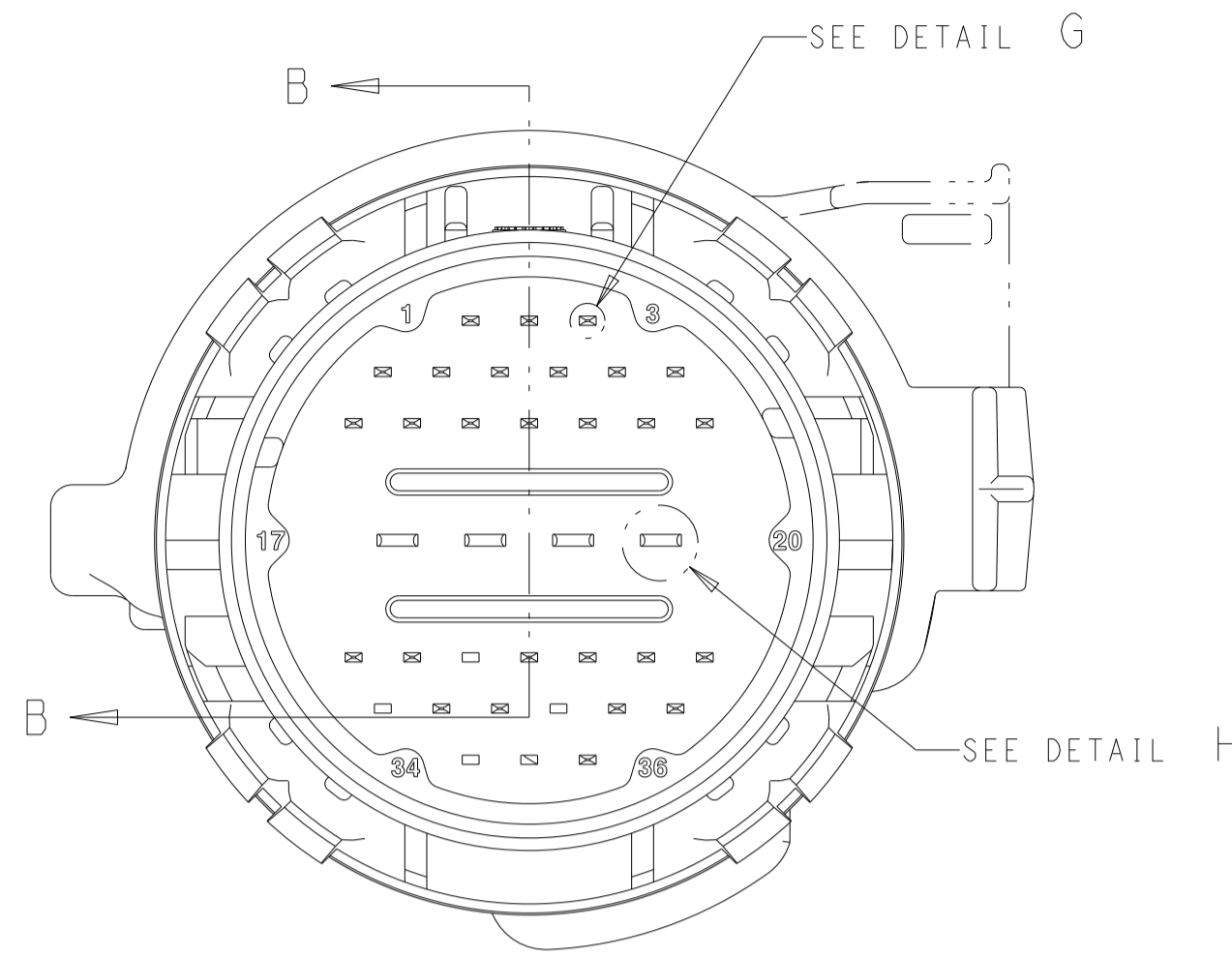

SECTION B-B

<p>SCALE 2:1 2356151-1 KEYING OPTION "A"</p>	<p>SCALE 2:1 2356151-2 KEYING OPTION "B"</p>	<p>SCALE 2:1 2356151-3 KEYING OPTION "C"</p>	<p>SCALE 2:1 2356151-4 KEYING OPTION "D"</p>
<p>SCALE 2:1 2356151-5 KEYING OPTION "A", 27P DE-POPULATION</p>	<p>SCALE 2:1 2356151-6 KEYING OPTION "A", 32P DE-POPULATION</p>	<p>SCALE 2:1 2356151-7 KEYING OPTION "A", 29P DE-POPULATION</p>	<p>SCALE 2:1 2356151-8 KEYING OPTION "A", 24P DE-POPULATION</p>

THIS DRAWING IS A CONTROLLED DOCUMENT.		OWN: J. SHIRK, ZOMAY2019	TE Connectivity NAME: 36 POSITION SEALED CAP ASSEMBLY TRANSMISSION PASS-THRU (32X 1.2MM AND 4X 2.8MM TABS)
DIMENSIONS: mm		CHK: K. FAY, ZOMAY2019	
TOLERANCES UNLESS OTHERWISE SPECIFIED:		APVD: K. FAY, ZOMAY2019	SIZE: A 00779 C=2356151
0 PLC	±0.0	PRODUCT SPEC	RESTRICTED TO
1 PLC	±0.5	APPLICATION SPEC	SCALE 2:1 SHEET 2 OF 4 REV A
2 PLC	±0.13		
3 PLC	±0.05		
4 PLC	±0.0		
ANGLES	±0.0		
FINISH	±3°		
MATERIAL:		RESTRICTED CUSTOMER	

REVISIONS				
P	LTN	DESCRIPTION	DATE	APVD
-		SEE SHEET 1	-	-

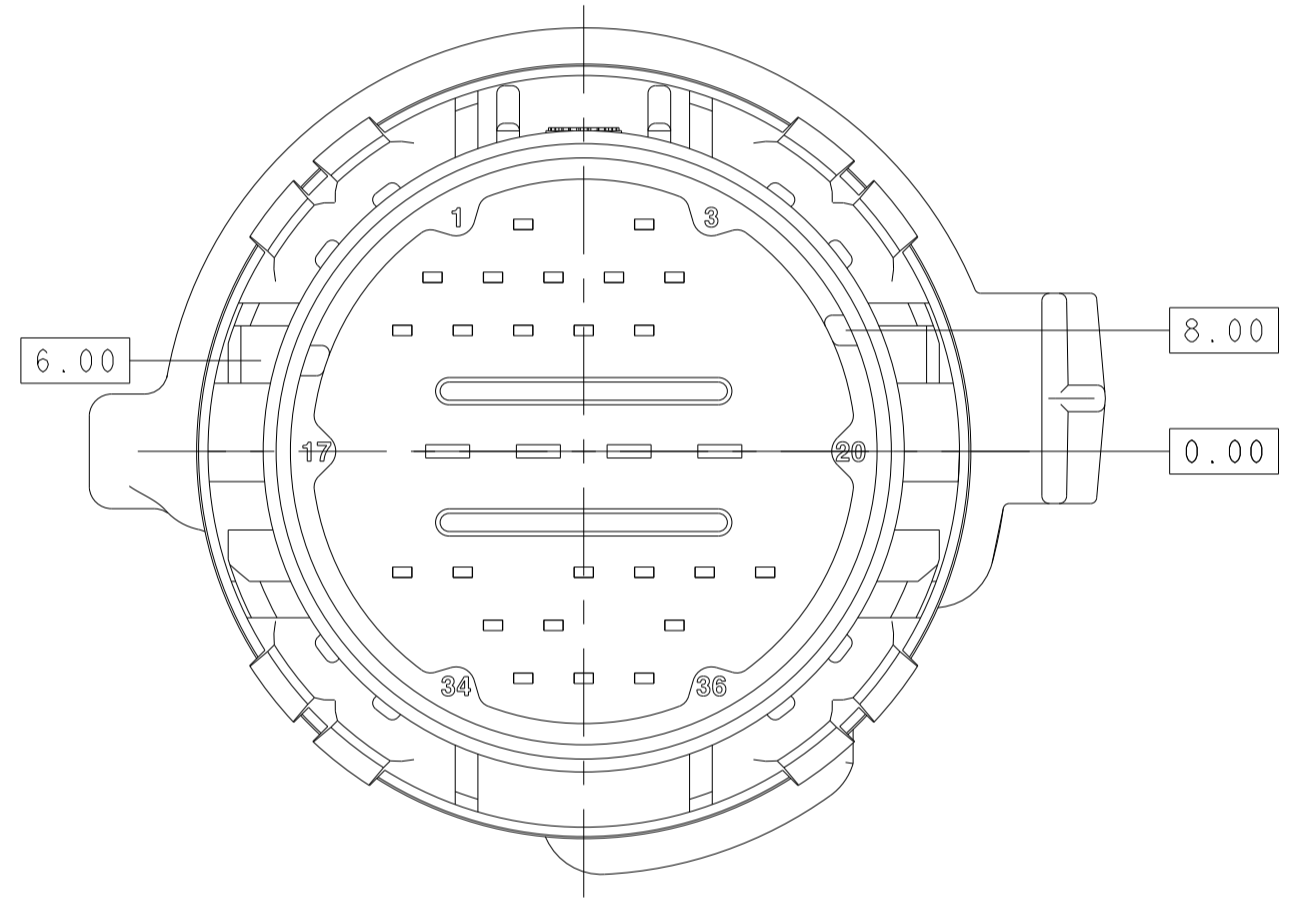

SCALE 2:1
2356151-9
KEYING OPTION "A", 28P DE-POPULATION

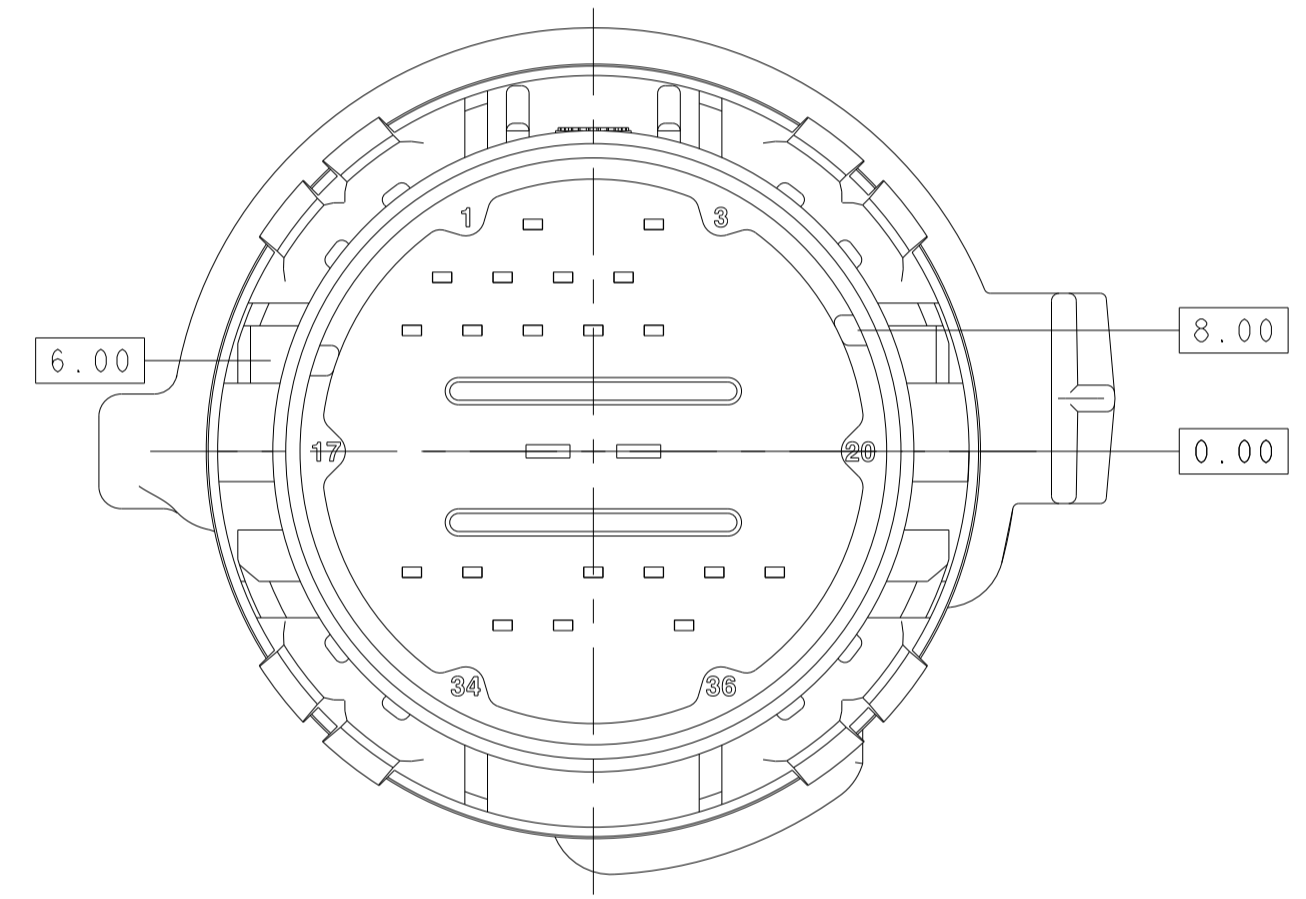

SCALE 2:1
1-2356151-0
KEYING OPTION "A", 22P DE-POPULATION

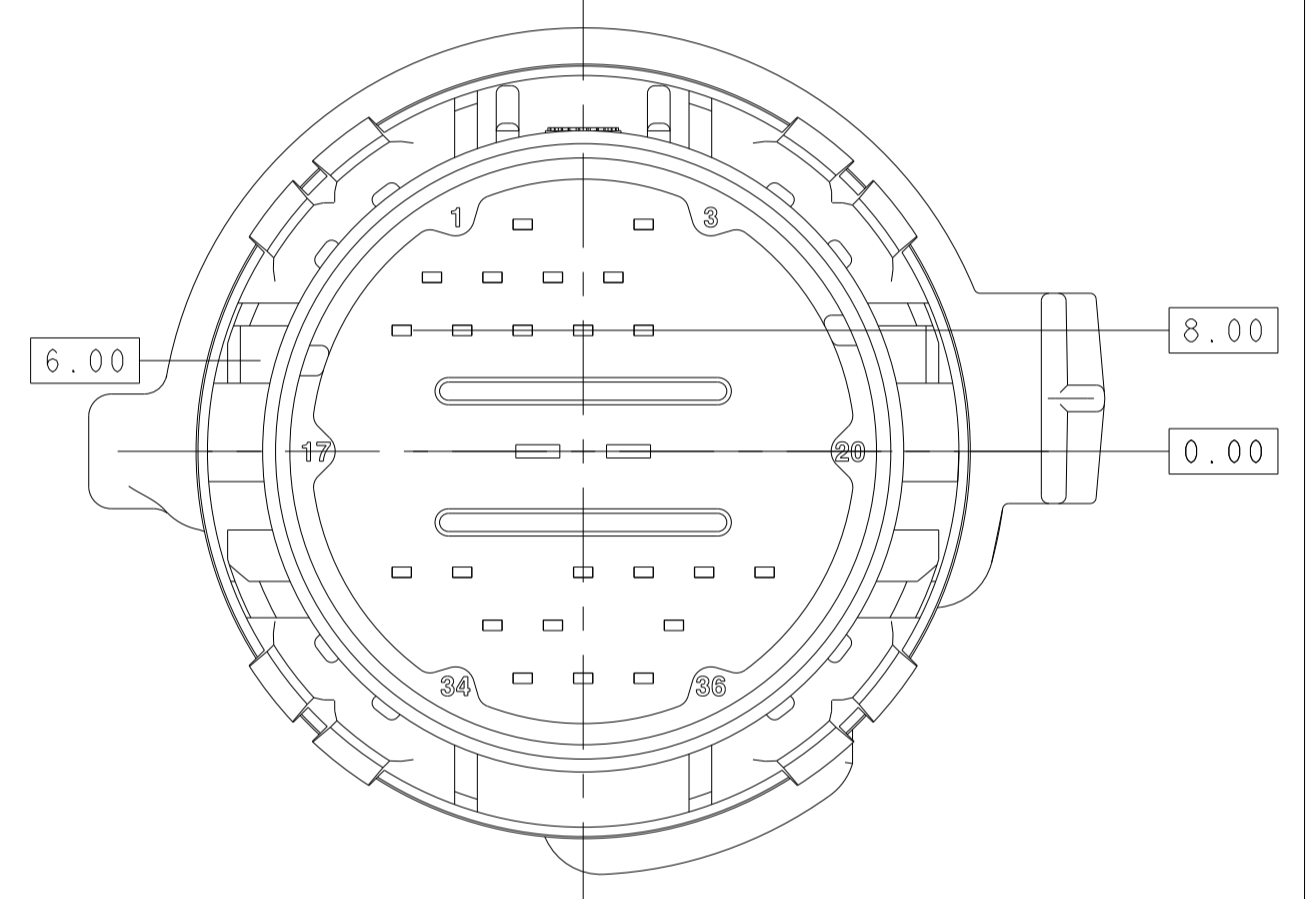

SCALE 2:1
1-2356151-1
KEYING OPTION "A", 25P DE-POPULATION

THIS DRAWING IS A CONTROLLED DOCUMENT.		DWN J. SHIRK 20MAY2019	
DIMENSIONS: mm		CHK K. FAY 20MAY2019	
		APVD K. FAY 20MAY2019	NAME 36 POSITION SEALED CAP ASSEMBLY TRANSMISSION PASS-THRU (32X 1.2MM AND 4X 2.8MM TABS)
TOLERANCES UNLESS OTHERWISE SPECIFIED: 0 PLC ±0.0 1 PLC ±0.5 2 PLC ±0.13 3 PLC ±0.05 4 PLC ±0.0 ANGLES ±3° FINISH		PRODUCT SPEC APPLICATION SPEC	RESTRICTED TO
MATERIAL		WEIGHT	SIZE CAGE CODE DRAWING NO A 00779 C=2356151
		RESTRICTED CUSTOMER	SCALE 2:1 SHEET 3 OF 4 REV A

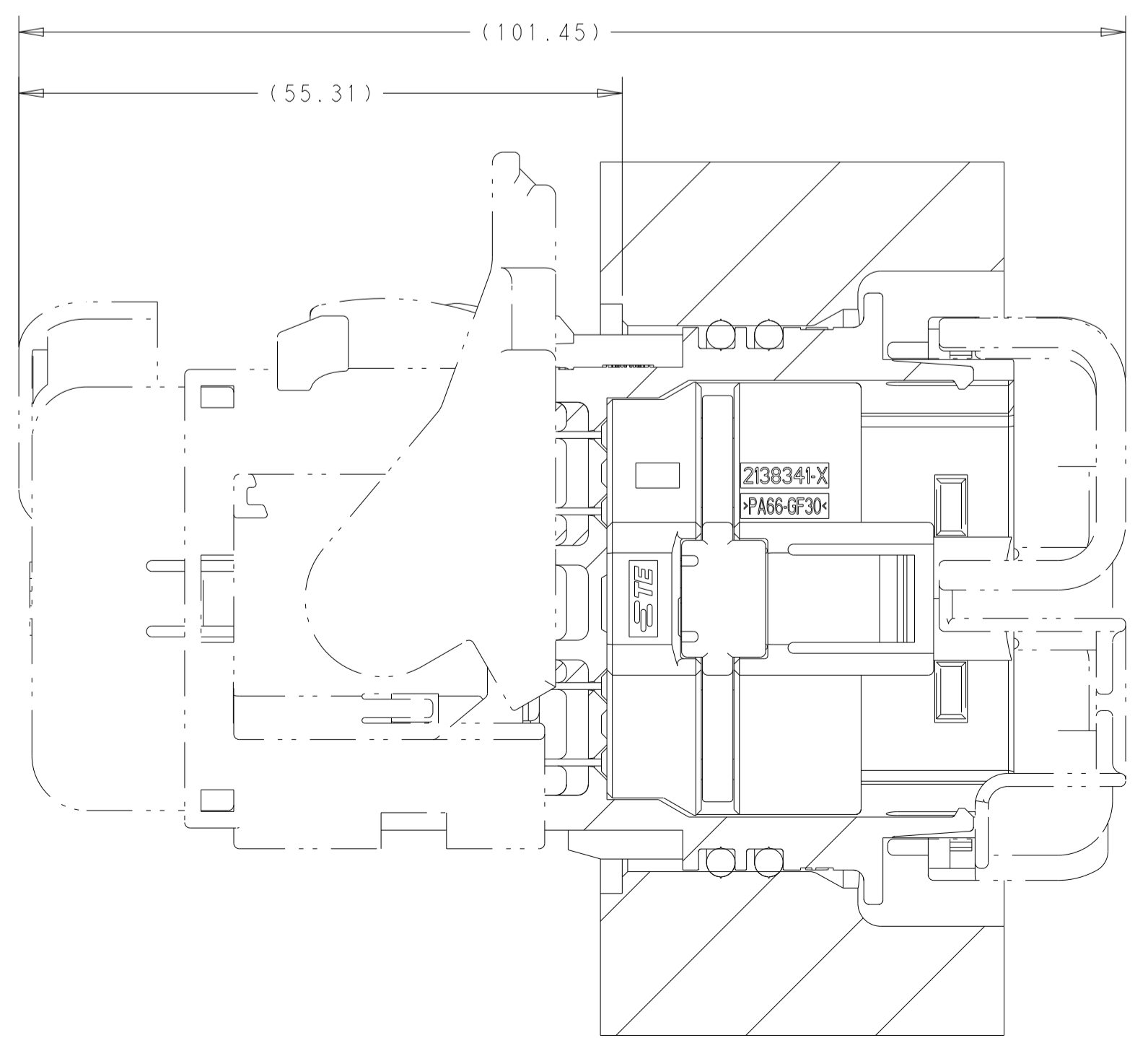
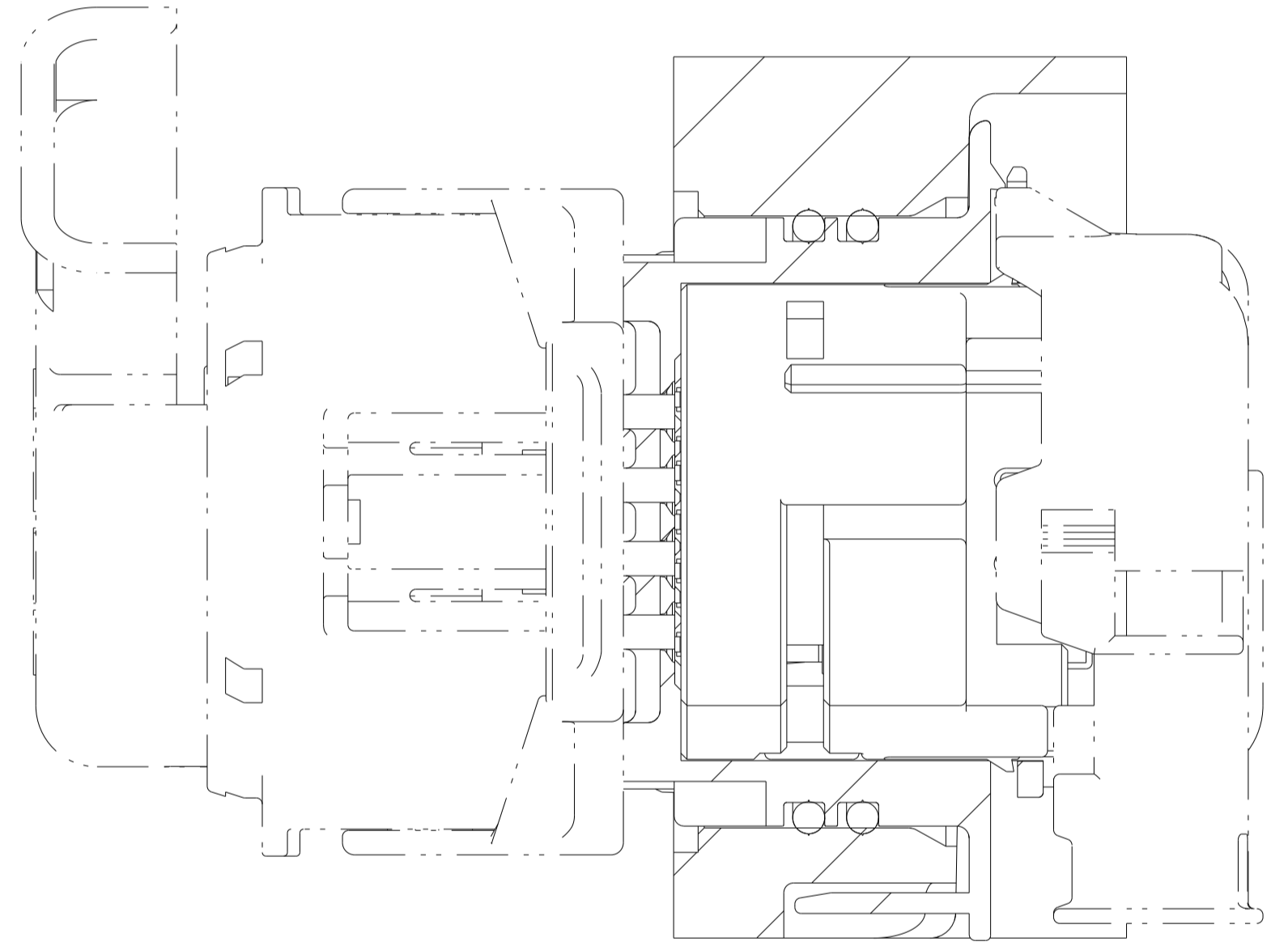
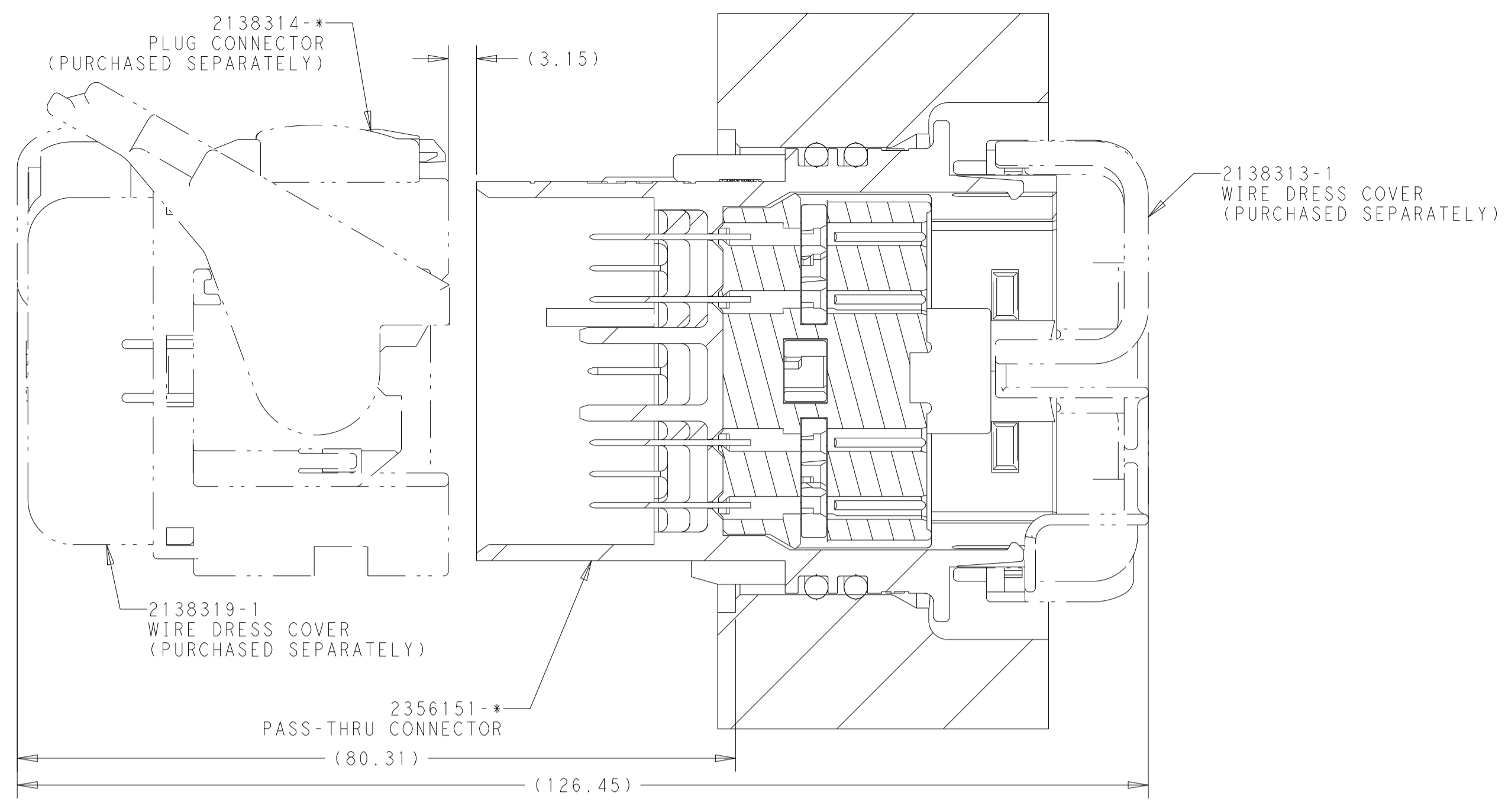

REVISIONS				
P	LTN	DESCRIPTION	DATE	APVD
-	-	SEE SHEET 1	-	-

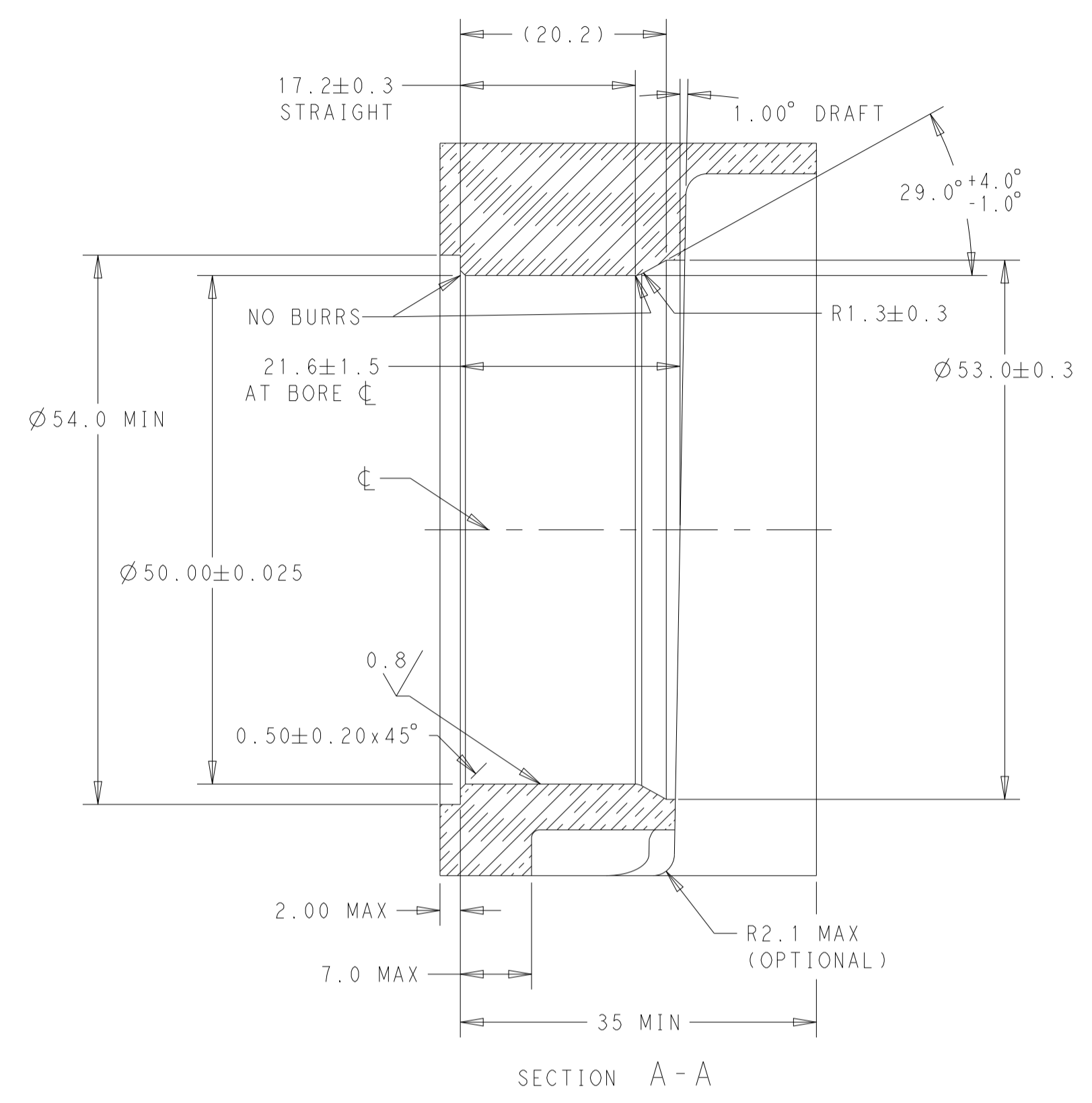

RECOMMENDED MOUNTING HOLE DETAIL

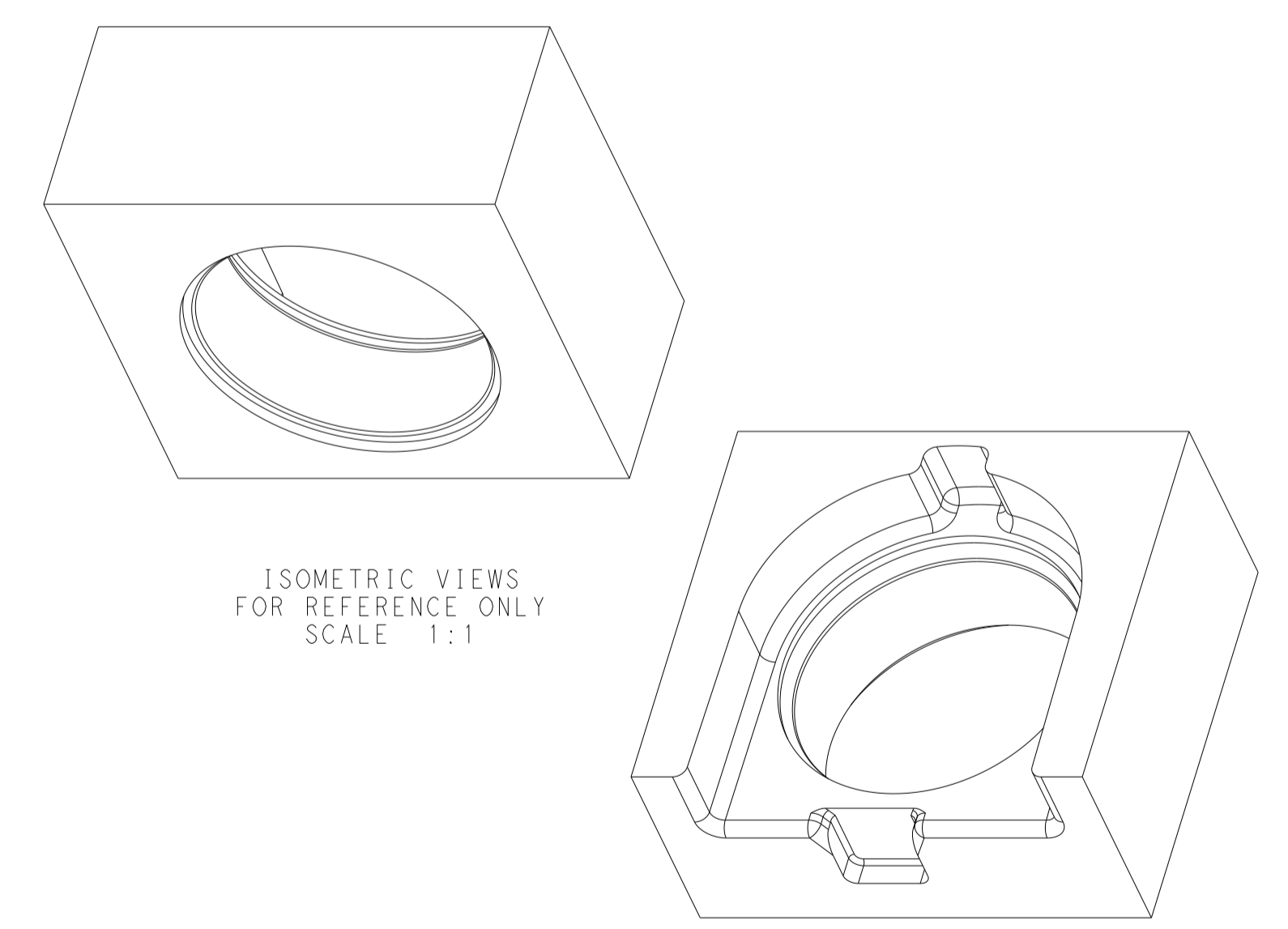
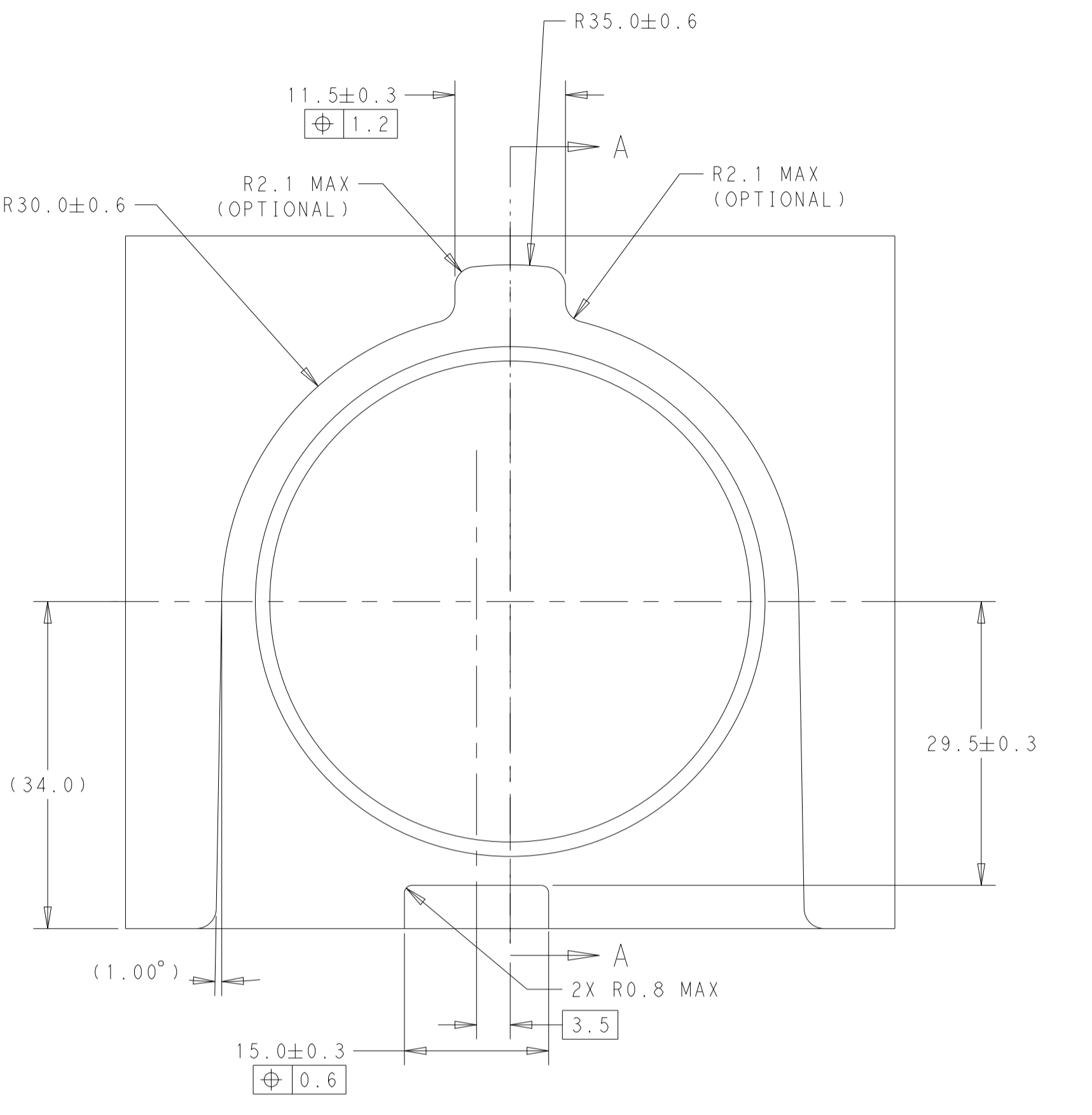
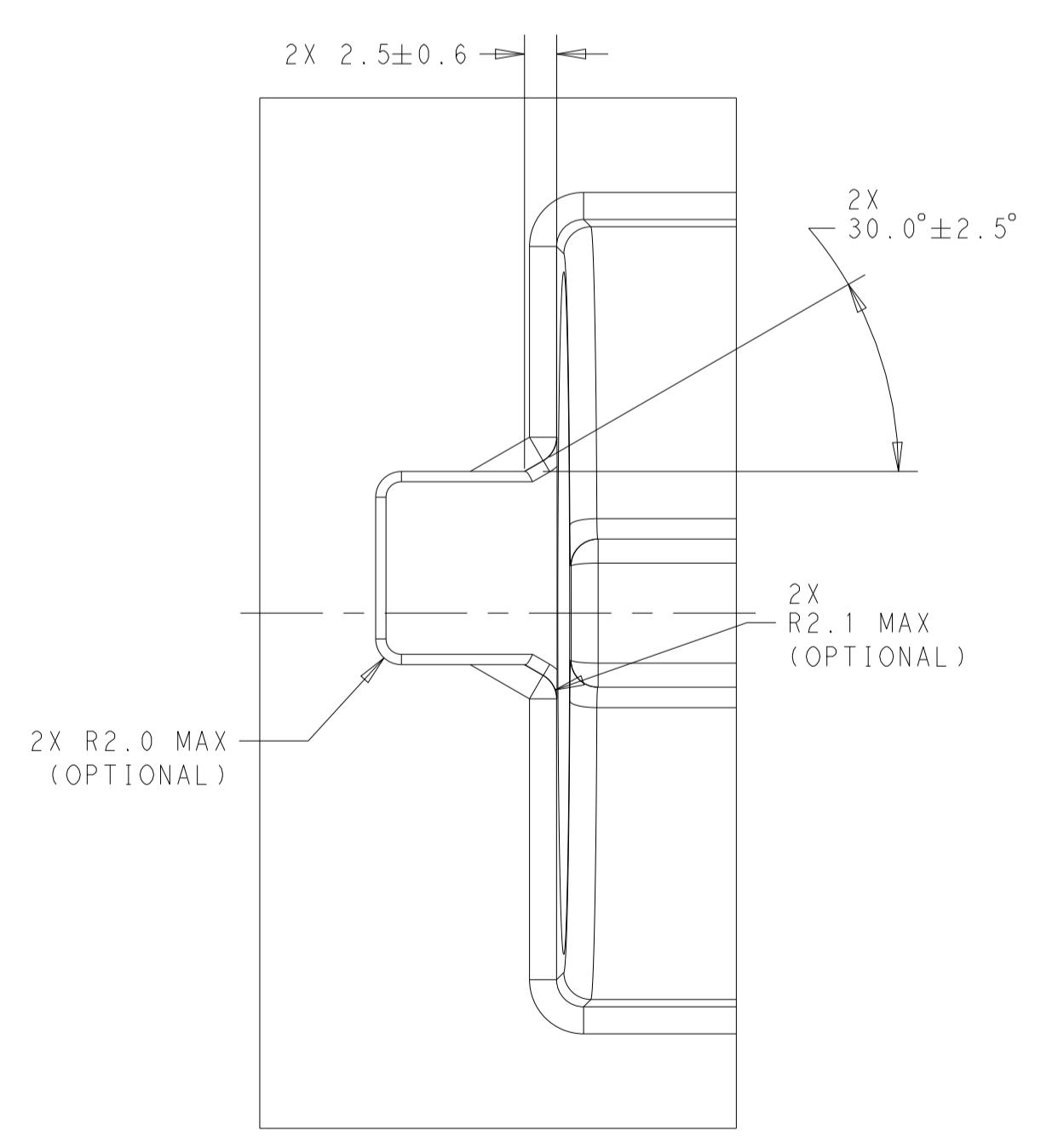

THIS DRAWING IS A CONTROLLED DOCUMENT.		DWN J. SHIRK 20MAY2019	
DIMENSIONS:		CHK K. FAY 20MAY2019	
mm	TOLERANCES UNLESS OTHERWISE SPECIFIED:	APVD K. FAY 20MAY2019	NAME 36 POSITION SEALED CAP ASSEMBLY TRANSMISSION PASS-THRU (32X 1.2MM AND 4X 2.8MM TABS)
	0 PLC ±0.0	PRODUCT SPEC	APPLICATION SPEC
	1 PLC ±0.5		
	2 PLC ±0.13		
	3 PLC ±0.05		
	4 PLC ±0.0		
	ANGLES ±3°		
MATERIAL	FINISH	WEIGHT	RESTRICTED TO
-	-	-	A 00779 C=2356151
RESTRICTED CUSTOMER		SCALE 2:1	SHEET 4 OF 4 REV A