

Datasheet

CON SMA024-G SMA Jack PCB Cutout Edge Mount Connector

Operating from 0 GHz to 18 GHz, the CON SMA024-G provides high performance and reliability in a small package. Mounting in a cutout/notch in a printed circuit board (PCB) and available in tape and reel packaging, the CON SMA024-G is more compact than standard board edge mount connectors and is compatible with pick and place machines for high volume manufacturing. Additionally, all Linx connectors meet RoHS lead free standards and are tested to meet requirements for corrosion resistance, vibration, mechanical and thermal shock.

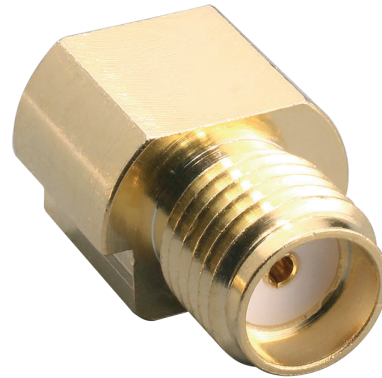

Features

- 0 to 18 GHz operation
- SMA jack (female socket) connection
 - Gold plated brass connector body
 - Gold plated phosphor bronze center contact
- Direct surface-mount PCB attachment
- Reflow- or hand-solder assembly

Electrical Specifications

Impedance	50 Ω
Frequency Range	0 to 18 GHz
Insulation Resistance	5000 M Ω min.
Voltage Rating	750 V RMS
Contact Resistance	Center: \leq 2.0 m Ω Outer: \leq 2.0 m Ω
Insertion Loss (dB max)	-0.42 @ 6 GHz
VSWR (max)	1.15 @ 6 GHz

Ordering Information

Part Number	Description
CON SMA024-G	SMA jack (female socket), PCB cutout edge mount connector in trays (100 per tray)
CON SMA024-G-T	SMA jack (female socket), PCB cutout edge mount connector in tape and reel (500 per reel)

Available from Linx Technologies and select distributors and representatives.

Product Dimensions

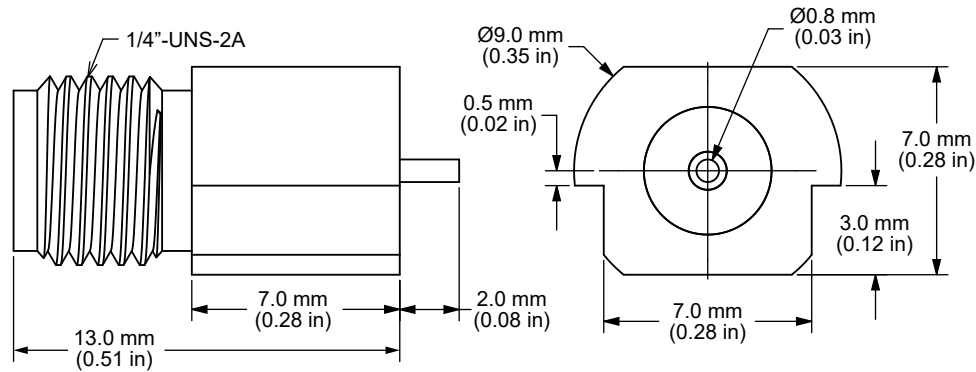

Figure 1. Product Dimensions for the CONSMA024-G Connector

Connector Components

CONSMA024-G		
Connector Part	Material	Finish
Connector Body	Brass	Gold
Center Contact	Phosphor Bronze	Gold
Insulator	PTFE	–

Recommended Footprint

Figure 2 shows the recommended PCB footprint and PCB cutout dimensions.

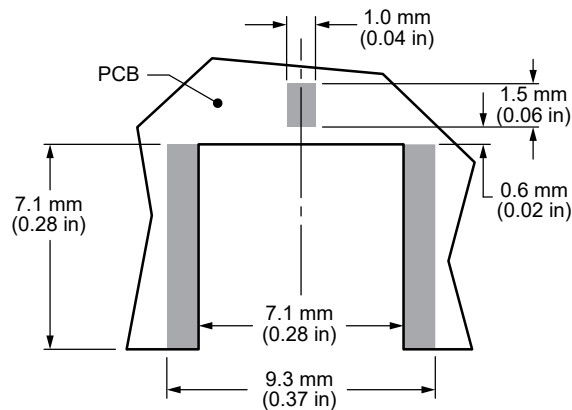

Figure 2. Recommended PCB Footprint for the CONSMA024-G Connector

Mechanical Specifications

CONSMA024-G	
Mounting Type	PCB Board Edge
Fastening Type	1/4\"-36 UNS-2A threaded coupling
Interface in Accordance with	MIL-STD-348A
Recommended Torque	0.57 N m (5.0 in lbs)
Coupling Nut Retention	60 lbs. min.
Connector Durability	500 cycles min.
Weight	3.2 g (0.11 oz)

Connector Performance

Table 1 shows insertion loss and VSWR values for the CONSMA024-G connector at commonly used frequencies.

Insertion loss is the loss of signal power (gain) resulting from the insertion of a device in a transmission line. VSWR describes how efficiently power is transmitted through the connector. A lower VSWR value indicates better performance at a given frequency.

Table 1. Insertion Loss and VSWR for the CONSMA024-G Connector

Band	Low-Band Cellular/ ISM/LPWA	Midband Cellular/ GNSS	WiFi/ISM	WiFi 6
Frequency Range	400 MHz to 960 MHz	1.1 GHz to 5 GHz	2.4 GHz	5 GHz to 7.125 GHz
Insertion Loss (dB max)	-0.07	-0.35	-0.17	-0.51
VSWR (max)	1.1	1.2	1.1	1.3

Environmental Specifications

MIL-STD/Method/Test Condition	
Corrosion (Salt spray)	MIL-STD-202 Method 101 test condition B
Thermal Shock	MIL-STD-202 Method 107 test condition B
Vibration	MIL-STD-202 Method 204 test condition D
Mechanical Shock	MIL-STD-202 Method 213 test condition I
Temperature Range	-55 °C to +155 °C
Environmental Compliance	RoHS

Reflow Solder Profile

Figure 3 shows the time and temperature data for reflow soldering the connector to a PCB.

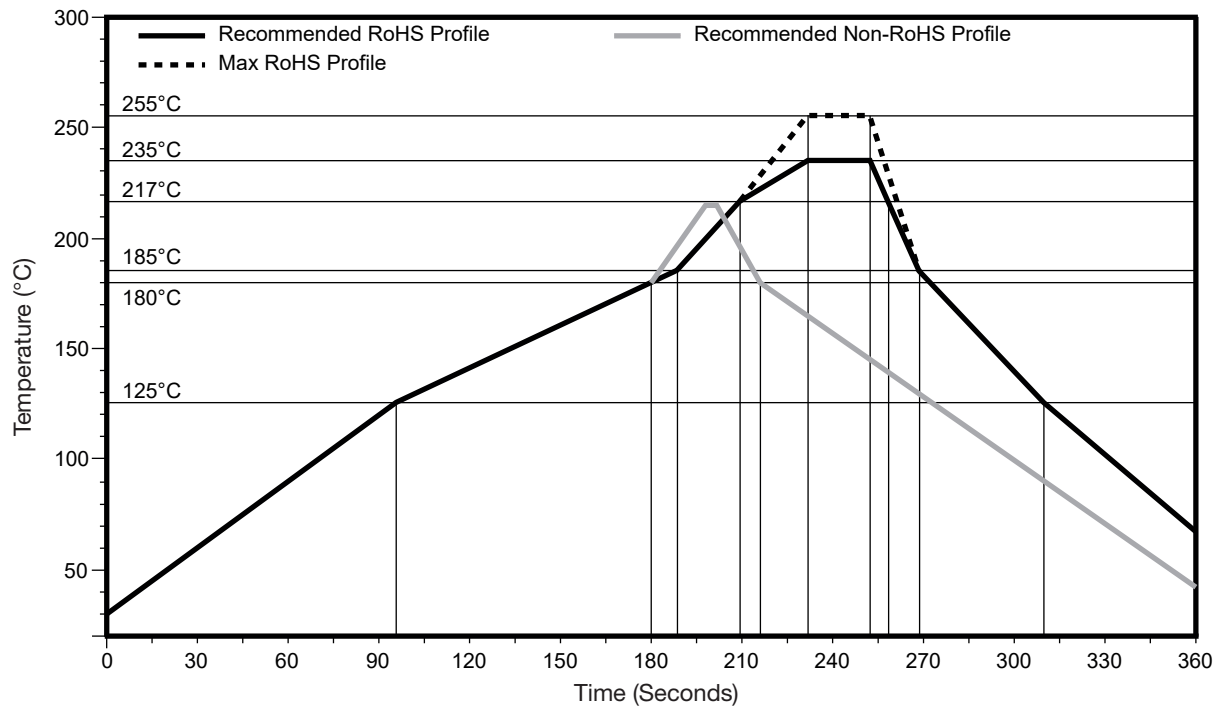

Figure 3. Recommended Reflow Solder Profile

Packaging Information

Figure 4 shows the tape dimensions for the CONSMA024-G-T connector. The reel specifications are provided in Figure 5.

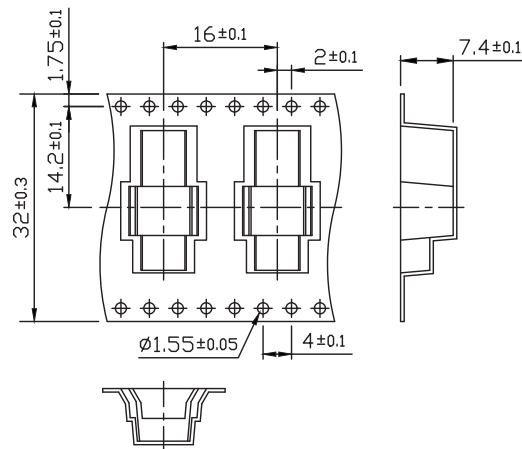
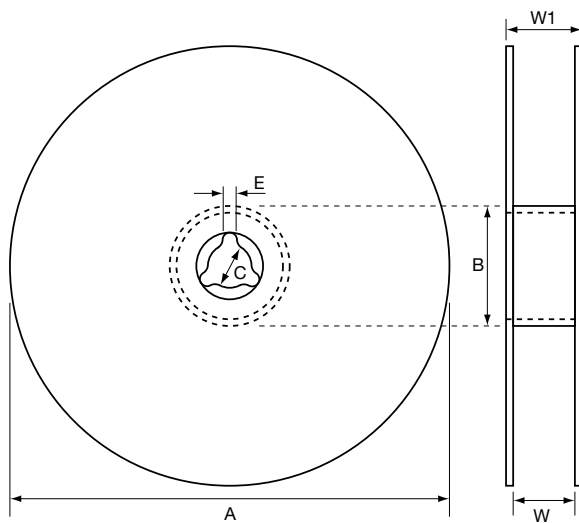

Figure 4. Tape Specifications for the CONSMA024-G-T Connector



Reel Dimensions		
Symbol	Qty	Unit
QTY per reel	500	pcs
Tape width	24.00	mm
A	∅ 330 ±1	mm
B	∅ 100 ±0.5	mm
C	∅ 13.00 ±0.2	mm
E	2.2 ±0.5	mm
W	24 ±0.5	mm
W1	28.4 ±0.2	mm

Figure 5. Reel Specifications for the CONSMA024-G-T Connector

Connector & Adapter Definitions and Useful Formulas

VSWR - Voltage Standing Wave Ratio. VSWR is a unitless ratio that describes how efficiently power is transmitted through the connector. A lower VSWR value indicates better performance at a given frequency. VSWR is easily derived from Return Loss.

$$\text{VSWR} = \frac{10^{\left[\frac{\text{Return Loss}}{20}\right]} + 1}{10^{\left[\frac{\text{Return Loss}}{20}\right]} - 1}$$

Insertion Loss - The loss of signal power (gain) resulting from the insertion of a device in a transmission line. Insertion loss can be derived from the power transmitted to the load before the insertion of the component P_T and the power transmitted to the load after the insertion of the component P_R .

$$\text{Insertion Loss (dB)} = 10 \log_{10} \frac{P_T}{P_R}$$

TE TECHNICAL SUPPORT CENTER

USA:	+1 (800) 522-6752
Canada:	+1 (905) 475-6222
Mexico:	+52 (0) 55-1106-0800
Latin/S. America:	+54 (0) 11-4733-2200
Germany:	+49 (0) 6251-133-1999
UK:	+44 (0) 800-267666
France:	+33 (0) 1-3420-8686
Netherlands:	+31 (0) 73-6246-999
China:	+86 (0) 400-820-6015

te.com

TE Connectivity, TE, TE connectivity (logo), Linx and Linx Technologies are trademarks owned or licensed by the TE Connectivity Ltd. family of companies. All other logos, products and/or company names referred to herein might be trademarks of their respective owners.

The information given herein, including drawings, illustrations and schematics which are intended for illustration purposes only, is believed to be reliable. However, TE Connectivity makes no warranties as to its accuracy or completeness and disclaims any liability in connection with its use. TE Connectivity's obligations shall only be as set forth in TE Connectivity's Standard Terms and Conditions of Sale for this product and in no case will TE Connectivity be liable for any incidental, indirect or consequential damages arising out of the sale, resale, use or misuse of the product. Users of TE Connectivity products should make their own evaluation to determine the suitability of each such product for the specific application.

TE Connectivity warrants to the original end user customer of its products that its products are free from defects in material and workmanship. Subject to conditions and limitations TE Connectivity will, at its option, either repair or replace any part of its products that prove defective because of improper workmanship or materials. This limited warranty is in force for the useful lifetime of the original end product into which the TE Connectivity product is installed. Useful lifetime of the original end product may vary but is not warranted to exceed one (1) year from the original date of the end product purchase.

©2023 TE Connectivity. All Rights Reserved.

04/23 Original