

P.C.B. LAYOUT

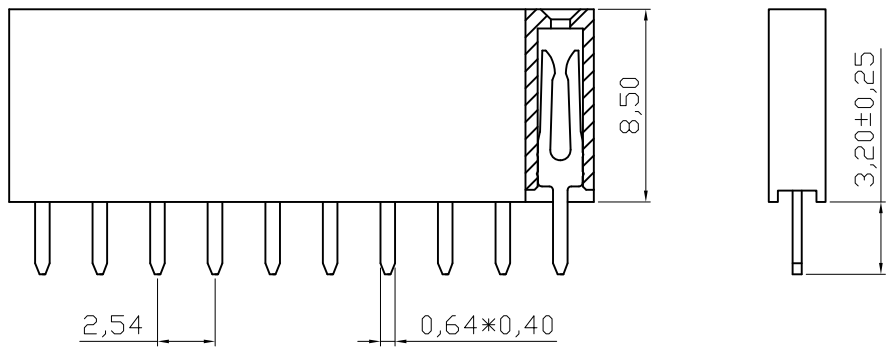

NOTES:

MATERIAL

- 1. Insulator Material: PBT+30%G.F(UL94V-0), Black
- 2. Contact Material : Brass
- 3. Contact Plating : Gold Flash or Tin plated

ELECTRICAL

- 1. Current Rating : 3.0Amps/contact max
- 2. Withstand Voltage : 1000V AC/minute
- 3. Contact Resistance : 20mΩ/contact max
- 4. Insulation Resistance: 1000MΩ min at Voltage=100V

ENVIRONMENTAL

- 1. Operation Temperature: -55°C to +105°C (Gold plated)
-40°C to +105°C (Tin plated)
- 2. Mechanical life cycle: min.200

Packing: Tray

Order code: A-BL254-EG-xxx D

Contact plating: G: Gold flash, Z: Tin plated
No. of Contacts

RoHS compliant
Unit: mm

Scale	Free						Date	Name	Customer-No.
TOLERANCE						Drawn	18.09.2000	Hellwig	ASSMANN WSW-No. A-BL254-EG- xxx D
X.	±0.50								
X.X	±0.30	④	Add Tin plating	07.05.2013	Amy	Approved	07.05.2013	Amy	Drawing-No. ASS 1034A CO
X.XX	±0.20	③	Update	27.09.2012	Amy				
X.XXX	±0.10	②	Modify drawing	27.07.2009	Dean				rev04
DIM	TOL	①	Drawn	18.09.2000	Hellwig				
Angle	±5°	Id.	Modification	Date	Name				SHEET

