

# System Reset IC with delay

## Monolithic IC PST89XA Series

### Outline

This IC is a reset IC for turning on/off power supply and power flicker in CPU or logic systems.  
 This IC can change delay time by an external capacitor.

### Features

1. Maximum supply voltage	7V
2. Detecting voltage accuracy	±1.0%
3. Low supply current	0.35µA typ.
4. Operating supply voltage	0.95 to 6.5V
5. Operating temperature	-40 to +105°C
6. Reset voltage rank	1.2 to 5.2V (0.1Vstep)
7. Reset temperature coefficient	±100ppm/°C typ.
8. Delay Resistance	10MΩ type.
9. Output type	Open drain, CMOS

### Packages

SC-82ABB  
 SOT-25A  
 PLP-4A

### Applications

1. The reset of CPU and MPU and logic circuit
2. Battery voltage check
3. Back-up circuit
4. Level detector

**Block Diagram**

**PST893Axxx Series (Delay Resistance 10MΩ type, CMOS Output)**

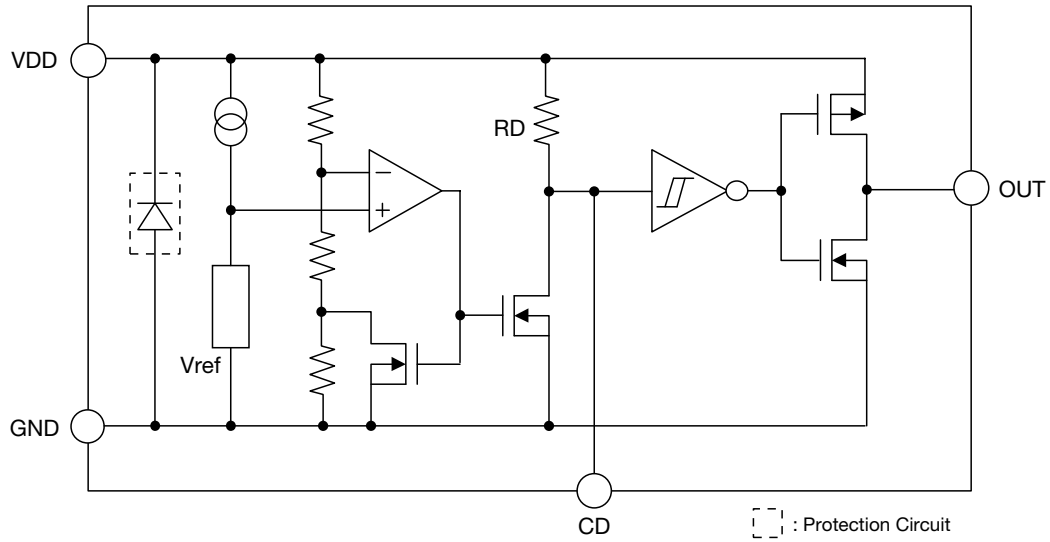

**PST894Axxx Series (Delay Resistance 10MΩ type, Open Drain Output)**

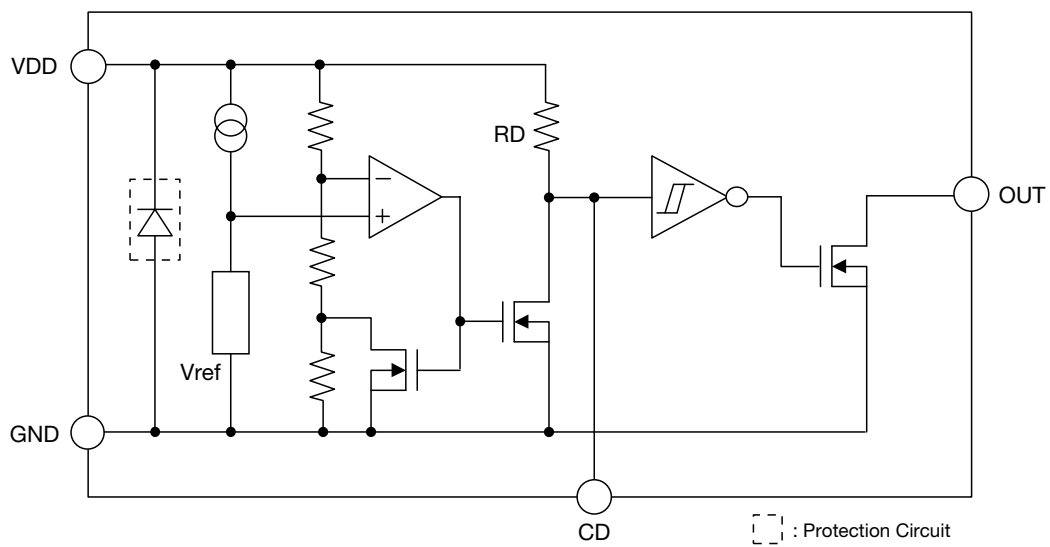

• Any products mentioned in this catalog are subject to any modification in their appearance and others for improvements without prior notification.  
 • The details listed here are not a guarantee of the individual products at the time of ordering. When using the products, you will be asked to check their specifications.

## Pin Assignment

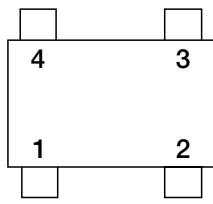

SC-82ABB  
(TOP VIEW)

1	GND
2	VDD
3	CD
4	OUT

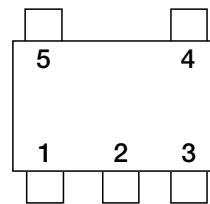

SOT-25A  
(TOP VIEW)

1	OUT
2	VDD
3	GND
4	NC
5	CD

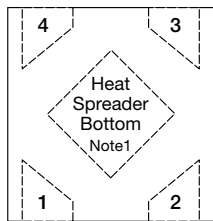

PLP-4A  
(TOP VIEW)

1	GND
2	OUT
3	CD
4	VDD

Note1 : Heat Spreader Bottom with GND.

## Pin Description

### SC-82ABB

Pin No.	Pin name	Functions
1	GND	GND Pin
2	VDD	VDD Pin / Voltage Detect Pin
3	CD	Capacitor Connect Pin with Delay
4	OUT	Reset Signal Output Pin

### SOT-25A

Pin No.	Pin name	Functions
1	OUT	Reset Signal Output Pin
2	VDD	VDD Pin / Voltage Detect Pin
3	GND	GND Pin
4	NC	No Connection
5	CD	Capacitor Connect Pin with Delay

### PLP-4A

Pin No.	Pin name	Functions
1	GND	GND Pin
2	OUT	Reset Signal Output Pin
3	CD	Capacitor Connect Pin with Delay
4	VDD	VDD Pin / Voltage Detect Pin

**Absolute Maximum Ratings** (Except where noted otherwise Ta=25°C)

Item	Symbol	Ratings		Units
Supply Voltage	VDD max.	-0.3~+7.0		V
Output Voltage	OUT	PST893 Series	GND-0.3 ~ VDD max. +0.3 (CMOS Type)	V
		PST894 Series	GND-0.3 ~ +7.0 (N-ch Open Drain Type)	
Input Current (VDD)	IDD	20		mA
Output current (RESET, $\overline{\text{RESET}}$ )	IOUT	20		mA
CD Pin Input Voltage	VCD	GND-0.3 ~ +VDD+0.3		V
Power dissipation	Pd	150 (SC-82AB, SOT-25A)		mW
		400 (PLP-4A) (Note2)		mW
Operating temperature	Topr	-40~+105		°C
Storage temperature	Tstg	-65~+150		°C

Note2 : With PC board of glass epoxy.

**Recommended Operating Conditions**

Item	Symbol	Ratings	Units
Operating Temperature	Topr	-40~+105	°C
Supply Voltage	VDD	0.95~6.5	V

**Model Name**

P S T 8 9  A

a b c d e

a		b		c		d		e	
Output Type		CD pin charge Type		Detecting Voltage Rank		Package		Packing Specifications	
3	CMOS Output	A	delay Resistance	120	V <sub>TH</sub> =1.20V	U	SC-82ABB	R	R HOUSING Halogen-contained Product
4	Open drain Output			∩	∩	N	SOT-25A	L	L HOUSING Halogen-contained Product
				520	V <sub>TH</sub> =5.20V	R	PLP-4A	M	R HOUSING Halogen-free Product
								H	L HOUSING Halogen-free Product

• Any products mentioned in this catalog are subject to any modification in their appearance and others for improvements without prior notification.  
 • The details listed here are not a guarantee of the individual products at the time of ordering. When using the products, you will be asked to check their specifications.

**Electrical Characteristics** (Except where noted otherwise Ta=25°C)

Item	Symbol	Measurement conditions	Rank	Min.	Typ.	Max.	Units	Circuit
Reset threshold	V <sub>TH</sub>	Ta=+25°C Ta=-40~+85°C	120	1.1880	1.2000	1.2120	V	2
				1.1700		1.2300		
			130	1.2870	1.3000	1.3130		
				1.2675		1.3325		
			140	1.3860	1.4000	1.4140		
				1.3650		1.4350		
			150	1.4850	1.5000	1.5150		
				1.4625		1.5375		
			160	1.5840	1.6000	1.6160		
				1.5600		1.6400		
			170	1.6830	1.7000	1.7170		
				1.6575		1.7425		
			180	1.7820	1.8000	1.8180		
				1.7550		1.8450		
			190	1.8810	1.9000	1.9190		
				1.8525		1.9475		
			200	1.9800	2.0000	2.0200		
				1.9500		2.0500		
			210	2.0790	2.1000	2.1210		
				2.0475		2.1525		
			220	2.1780	2.2000	2.2220		
				2.1450		2.2550		
			230	2.2770	2.3000	2.3230		
				2.2425		2.3575		
			240	2.3760	2.4000	2.4240		
				2.3400		2.4600		
			250	2.4750	2.5000	2.5250		
				2.4375		2.5625		
			260	2.5740	2.6000	2.6260		
				2.5350		2.6650		
			270	2.6730	2.7000	2.7270		
				2.6325		2.7675		
			280	2.7720	2.8000	2.8280		
				2.7300		2.8700		
290	2.8710	2.9000	2.9290					
	2.8275		2.9725					
300	2.9700	3.0000	3.0300					
	2.9250		3.0750					
310	3.0690	3.1000	3.1310					
	3.0225		3.1775					
320	3.1680	3.2000	3.2320					
	3.1200		3.2800					
330	3.2670	3.3000	3.3330					
	3.2175		3.3825					
340	3.3660	3.4000	3.4340					
	3.3150		3.4850					

Note3 : This device is tested at Ta=25°C, over temperature limits guaranteed by design only.

Note4 : The parameter is guaranteed by design.

Item	Symbol	Measurement conditions	Rank	Min.	Typ.	Max.	Units	Circuit
Reset threshold	V <sub>TH</sub>	Ta=+25°C Ta=-40~+85°C	350	3.4650	3.5000	3.5350	V	2
				3.4125		3.5875		
			360	3.5640	3.6000	3.6360		
				3.5100		3.6900		
			370	3.6630	3.7000	3.7370		
				3.6075		3.7925		
			380	3.7620	3.8000	3.8380		
				3.7050		3.8950		
			390	3.8610	3.9000	3.9390		
				3.8025		3.9975		
			400	3.9600	4.0000	4.0400		
				3.9000		4.1000		
			410	4.0590	4.1000	4.1410		
				3.9975		4.2025		
			420	4.1580	4.2000	4.2420		
				4.0950		4.3050		
			430	4.2570	4.3000	4.3430		
				4.1925		4.4075		
			440	4.3560	4.4000	4.4440		
				4.2900		4.5100		
			450	4.4550	4.5000	4.5450		
				4.3875		4.6125		
			460	4.5540	4.6000	4.6460		
				4.4850		4.7150		
470	4.6530	4.7000	4.7470					
	4.5825		4.8175					
480	4.7520	4.8000	4.8480					
	4.6800		4.9200					
490	4.8510	4.9000	4.9490					
	4.7775		5.0225					
500	4.9500	5.0000	5.0500					
	4.8750		5.1250					
510	5.0490	5.1000	5.1510					
	4.9725		5.2275					
520	5.1480	5.2000	5.2520					
	5.0700		5.3300					

Note3 : This device is tested at Ta=25°C, over temperature limits guaranteed by design only.

Note4 : The parameter is guaranteed by design.

Item	Symbol	Measurement conditions	Rank	Min.	Typ.	Max.	Units	Circuit
Reset threshold hysteresis	$\Delta V_{TH}$	$V_{DD}=0V \rightarrow V_{TH}+1V \rightarrow 0V$	120	0.036	0.060	0.096	V	2
			130	0.039	0.065	0.104		
			140	0.042	0.070	0.112		
			150	0.045	0.075	0.120		
			160	0.048	0.080	0.128		
			170	0.051	0.085	0.136		
			180	0.054	0.090	0.144		
			190	0.057	0.095	0.152		
			200	0.060	0.100	0.160		
			210	0.063	0.105	0.168		
			220	0.066	0.110	0.176		
			230	0.069	0.115	0.184		
			240	0.072	0.120	0.192		
			250	0.075	0.125	0.200		
			260	0.078	0.130	0.208		
			270	0.081	0.135	0.216		
			280	0.084	0.140	0.224		
			290	0.087	0.145	0.232		
			300	0.090	0.150	0.240		
			310	0.093	0.155	0.248		
			320	0.096	0.160	0.256		
			330	0.099	0.165	0.264		
			340	0.102	0.170	0.272		
			350	0.105	0.175	0.280		
			360	0.108	0.180	0.288		
			370	0.111	0.185	0.296		
			380	0.114	0.190	0.304		
			390	0.117	0.195	0.312		
			400	0.120	0.200	0.320		
			410	0.123	0.205	0.328		
			420	0.126	0.210	0.336		
			430	0.129	0.215	0.344		
440	0.132	0.220	0.352					
450	0.135	0.225	0.360					
460	0.138	0.230	0.368					
470	0.141	0.235	0.376					
480	0.144	0.240	0.384					
490	0.147	0.245	0.392					
500	0.150	0.250	0.400					
510	0.153	0.255	0.408					
520	0.156	0.260	0.416					

Note3 : This device is tested at Ta=25°C, over temperature limits guaranteed by design only.

Note4 : The parameter is guaranteed by design.

Item	Symbol	Measurement conditions	Rank	Min.	Typ.	Max.	Units	Circuit
Supply Current	I <sub>DD</sub>	V <sub>DD</sub> =V <sub>TH</sub> +1V	120 ~ 520		0.35	1.0	μA	1
Reset threshold temp. coefficient	ΔV <sub>TH</sub> /°C	T <sub>a</sub> =-40~+85°C	120 ~ 520		±100		ppm/°C	2
L transfer delay time (Note4)	t <sub>PHL</sub>	V <sub>DD</sub> =V <sub>TH</sub> +0.3V →V <sub>TH</sub> -0.3V	120 ~ 130		15	100	μs	4
		V <sub>DD</sub> =V <sub>TH</sub> +0.4V →V <sub>TH</sub> -0.4V	140 ~ 520					
H transfer delay time (Note4)	t <sub>PLH</sub>	V <sub>DD</sub> =V <sub>TH</sub> -0.3V →V <sub>TH</sub> +0.3V	120 ~ 130		15	100	μs	4
		V <sub>DD</sub> =V <sub>TH</sub> -0.4V →V <sub>TH</sub> +0.4V	140 ~ 520					
"L" Output Current	I <sub>OL1</sub>	V <sub>DD</sub> =0.95V, V <sub>DS</sub> =0.05V	120 ~ 520	0.01	0.10		mA	3
	I <sub>OL2</sub>	V <sub>DD</sub> =1.2V, V <sub>DS</sub> =0.5V V <sub>TH</sub> ≥1.3V	130 ~ 520	0.23	2.00			
	I <sub>OL3</sub>	V <sub>DD</sub> =2.4V, V <sub>DS</sub> =0.5V V <sub>TH</sub> ≥2.5V	250 ~ 520	1.60	8.00			
	I <sub>OL4</sub>	V <sub>DD</sub> =3.6V, V <sub>DS</sub> =0.5V V <sub>TH</sub> ≥3.7V	370 ~ 520	3.20	12.0			
"H" Output Current	I <sub>OH1</sub>	V <sub>DD</sub> =4.8V, V <sub>DS</sub> =0.5V V <sub>TH</sub> ≤4.7V PST893 series only	120 ~ 470	0.36	0.62		mA	4
	I <sub>OH2</sub>	V <sub>DD</sub> =6.1V, V <sub>DS</sub> =0.5V PST893 series only	120 ~ 520	0.46	0.75			
Output Leakage Current	I <sub>leak</sub>	V <sub>DD</sub> =6.5V, OUT=6.5V PST894 series only	120 ~ 520			0.1	μA	3
CD Pin Resistance	R <sub>D</sub>	PST89XA series	120 ~ 520	9	10	11	MΩ	5
CD Pin Threshold Voltage	V <sub>TCD</sub>	V <sub>DD</sub> =V <sub>TH</sub> ×1.1V	120 ~ 520	V <sub>DD</sub> ×0.3	V <sub>DD</sub> ×0.5	V <sub>DD</sub> ×0.7	V	4
CD Pin Output Current1	I <sub>CD1</sub>	V <sub>DD</sub> =0.95V V <sub>DS</sub> =0.1V	120 ~ 520	2.0	30.0		μA	5
CD Pin Output Current2	I <sub>CD2</sub>	V <sub>DD</sub> =1.0V V <sub>DS</sub> =0.5V	120 ~ 150	50	200		μA	5
		V <sub>DD</sub> =1.5V V <sub>DS</sub> =0.5V	160 ~ 520	200	800			

Note3 : This device is tested at T<sub>a</sub>=25°C, over temperature limits guaranteed by design only.

Note4 : The parameter is guaranteed by design.

Test Circuit

(1)

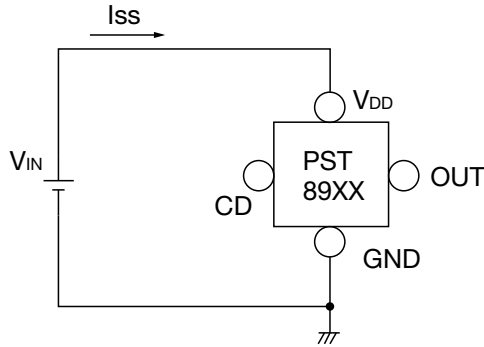

(2)

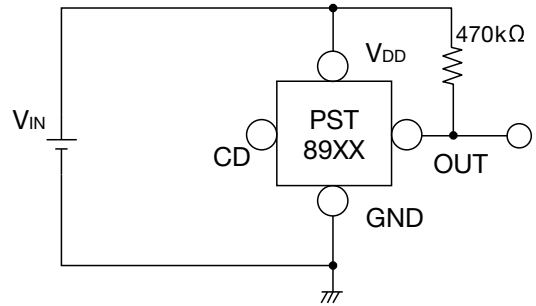

(3)

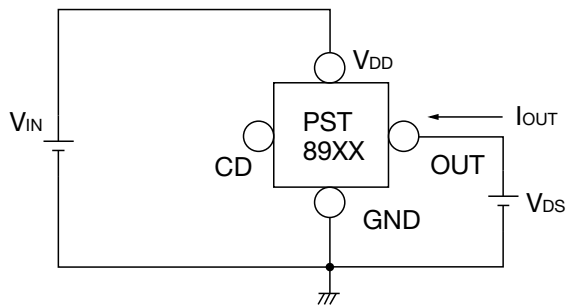

(4)

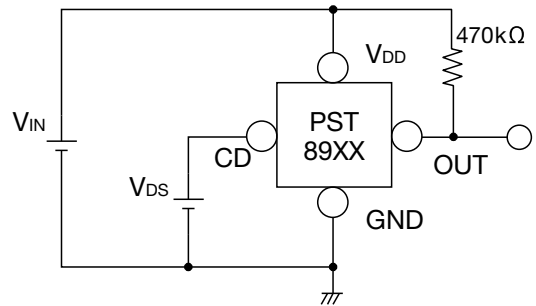

(5)

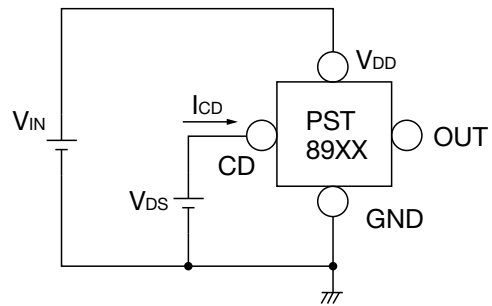
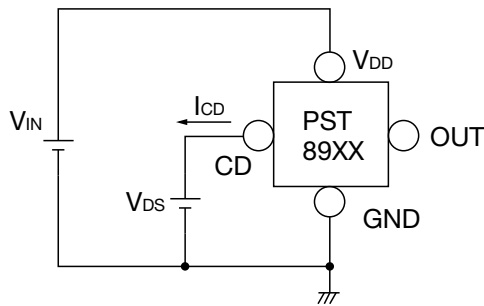

(6)

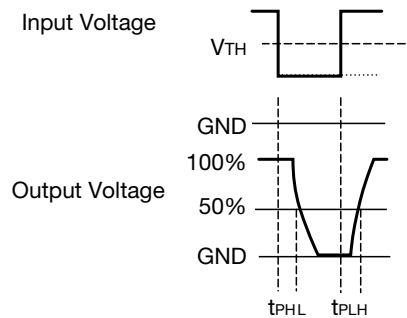
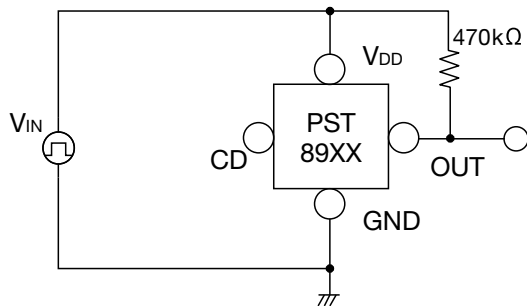

$V_{TH}=1.2V, 1.3V \rightarrow$  Input Voltage  $V_{TH}-0.3V \sim V_{TH}+0.3V$   
 $V_{TH}=1.4V \sim 5.2V \rightarrow$  Input Voltage  $V_{TH}-0.4V \sim V_{TH}+0.4V$

• Any products mentioned in this catalog are subject to any modification in their appearance and others for improvements without prior notification.  
 • The details listed here are not a guarantee of the individual products at the time of ordering. When using the products, you will be asked to check their specifications.

Timing Chart

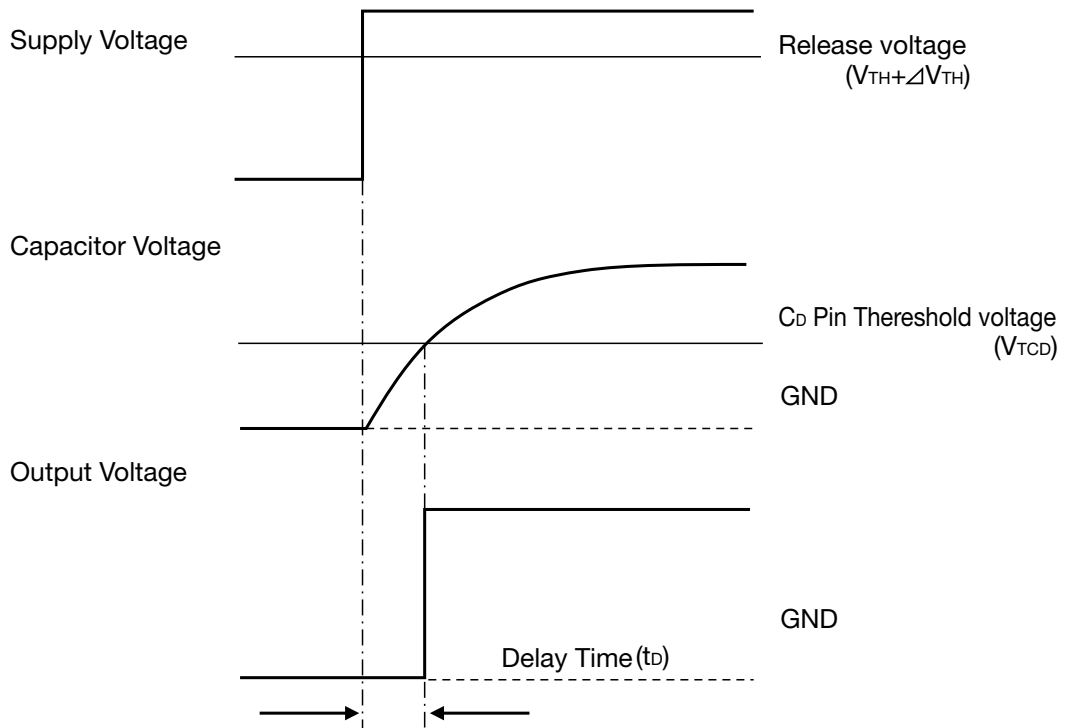

Delay Time ( $t_D$ ) PST89XA Series (10M $\Omega$ )  $R_D$  :  $C_D$  Pin Resistance  
 $t_D \doteq 0.69 \times R_D \times C_D$  (s)  $C_D$  : Capacitor

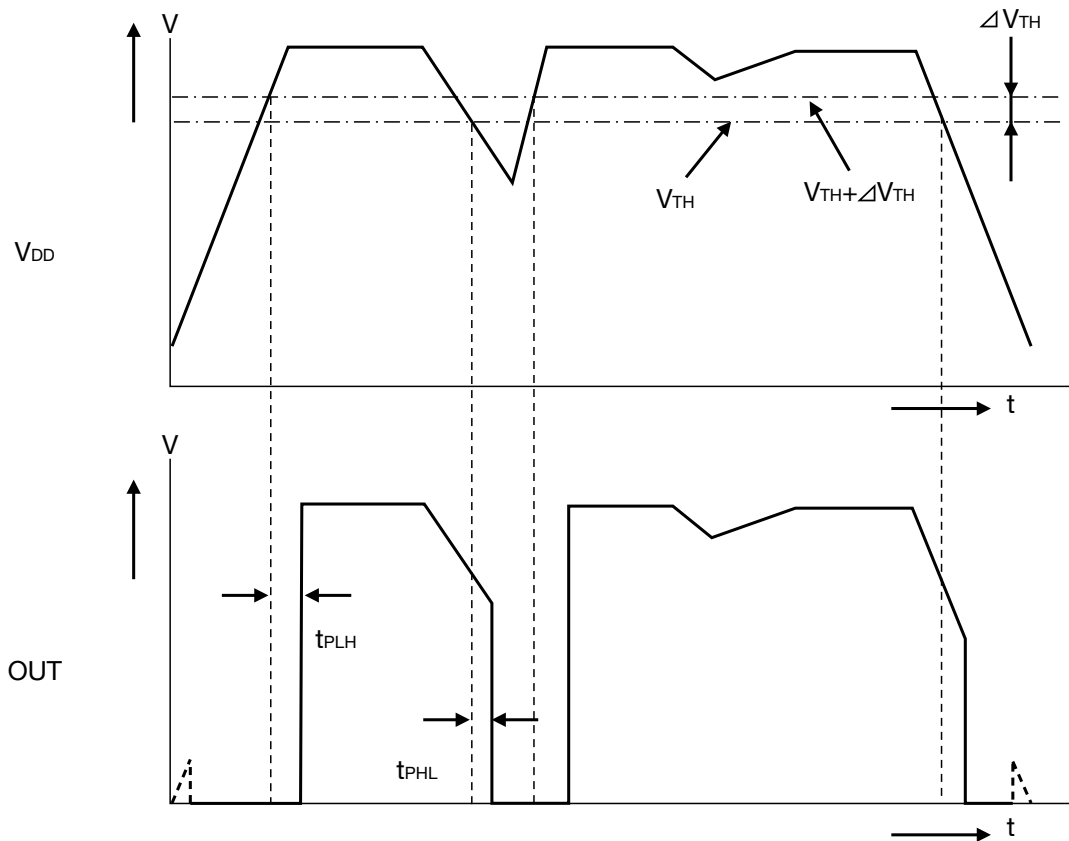

• Any products mentioned in this catalog are subject to any modification in their appearance and others for improvements without prior notification.  
 • The details listed here are not a guarantee of the individual products at the time of ordering. When using the products, you will be asked to check their specifications.

Application Circuits

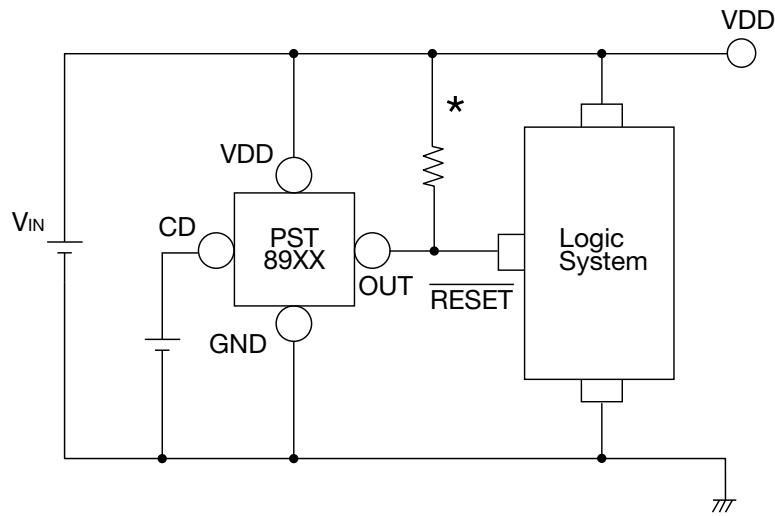

\* PST894 Series only

- We shall not be liable for any trouble or damage caused by using this circuit.
- In the event a problem which may affect industrial property or any other rights of us or a third party is encountered during the use of information described in these circuit, Mitsumi Electric Co., Ltd. shall not be liable for any such problem, nor grant a license therefore.

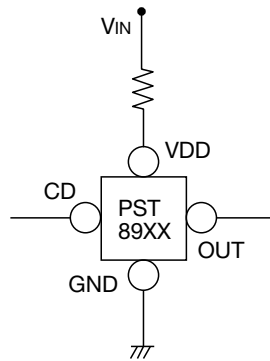

- Please note that there is any possibility of circuit oscillation when resistance put in the line VIN. In PST89xx, please make it less than 15k ohm.
- Heat Spreader Bottom (The electrode of the bottom central part) with VDD pin.

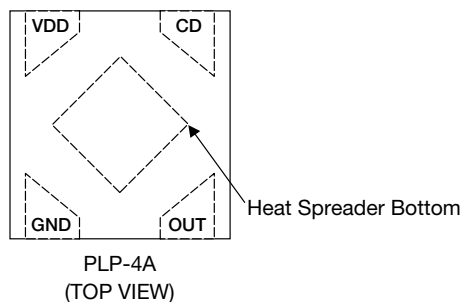

• Any products mentioned in this catalog are subject to any modification in their appearance and others for improvements without prior notification.  
 • The details listed here are not a guarantee of the individual products at the time of ordering. When using the products, you will be asked to check their specifications.

**Characteristics (2.8V)** (Except where noted otherwise Ta=25°C)

**■ Detecting Voltage**

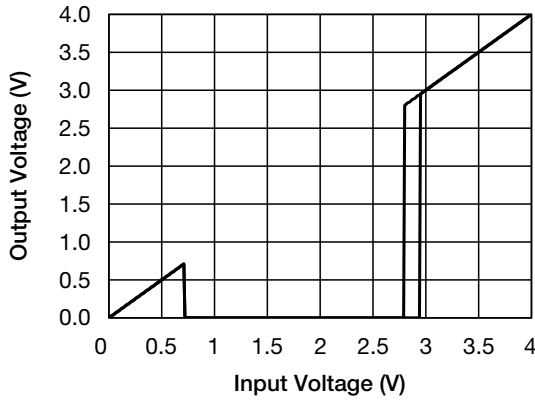

**■ Supply Current**

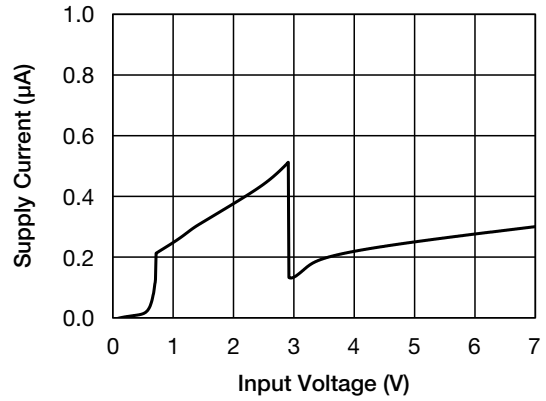

**■ Detecting Voltage - Temperature**

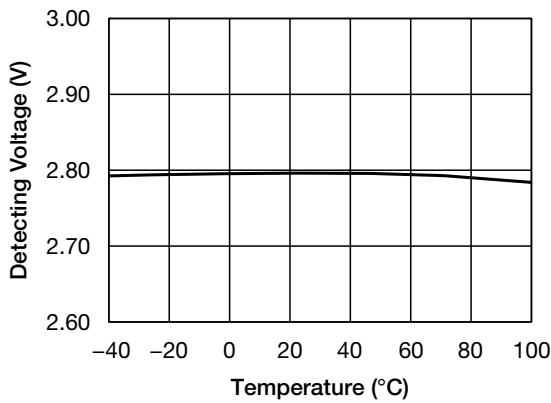

**■ Hysteresis Voltage - Temperature**

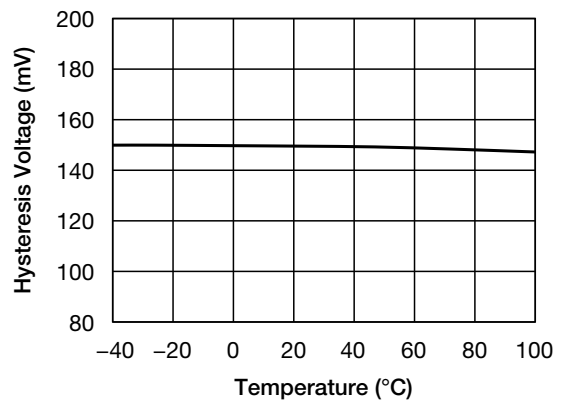

**■ "L"Output Current 1 - Temperature**

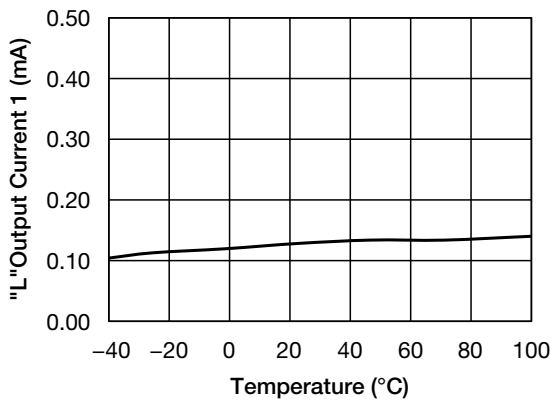

**■ "L"Output Current 2 - Temperature**

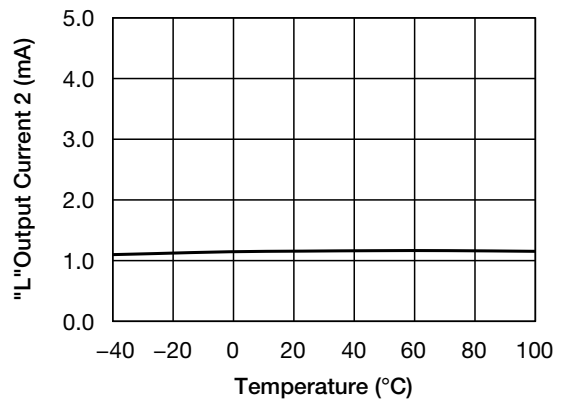

Note : \* These are typical characteristics.

• Any products mentioned in this catalog are subject to any modification in their appearance and others for improvements without prior notification.  
 • The details listed here are not a guarantee of the individual products at the time of ordering. When using the products, you will be asked to check their specifications.

■ "L" Output Current 3 - Temperature

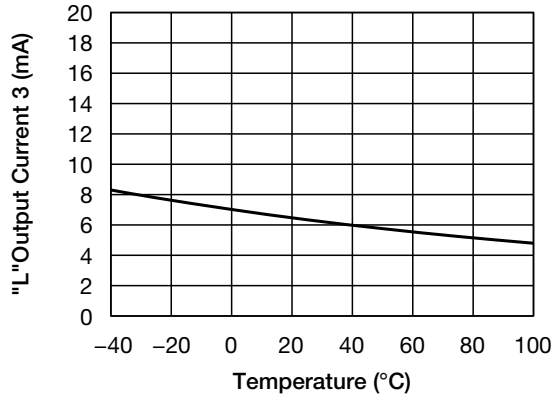

■ CD Pin Resistance - Temperature

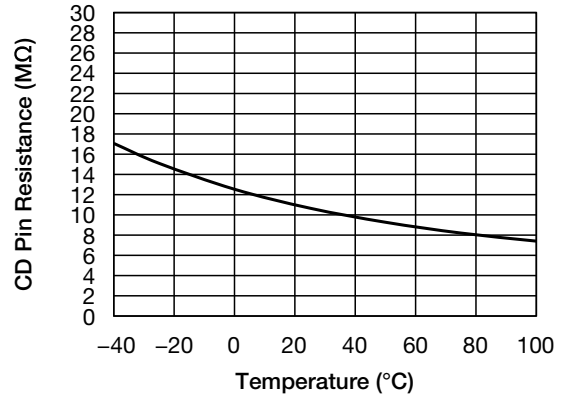

■ CD Pin Threshold Voltage - Temperature

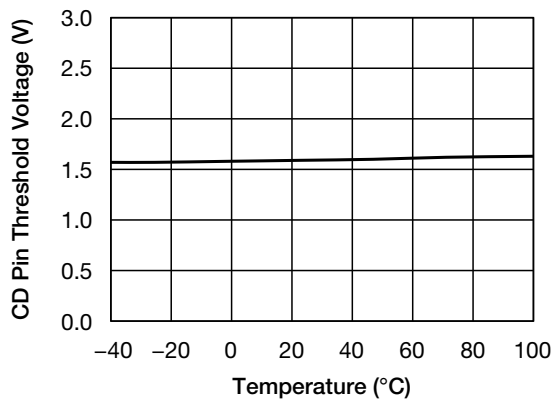

■ CD Pin Output Current

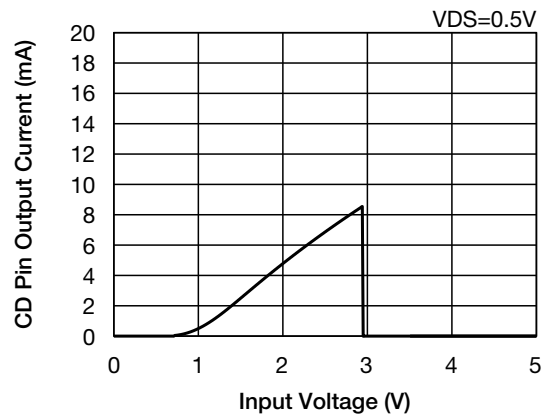

■ CD Pin Output Current 1 - Temperature

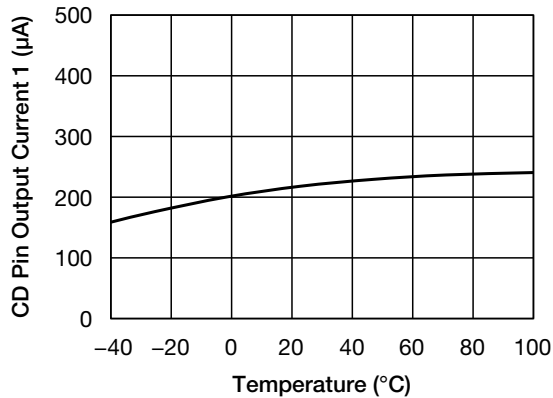

■ CD Pin Output Current 2 - Temperature

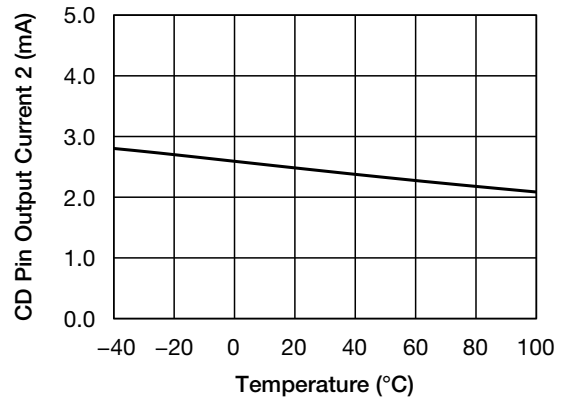

Note : \* These are typical characteristics.

• Any products mentioned in this catalog are subject to any modification in their appearance and others for improvements without prior notification.  
 • The details listed here are not a guarantee of the individual products at the time of ordering. When using the products, you will be asked to check their specifications.

■ N-ch Output Current

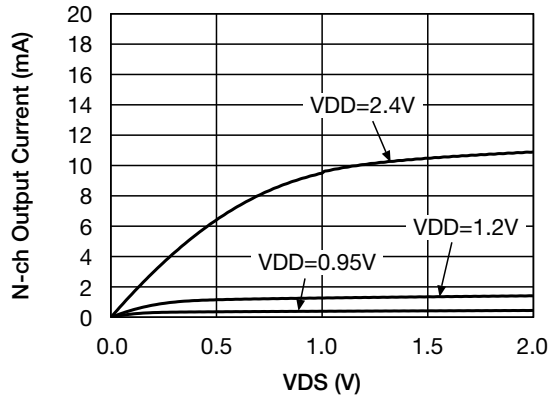

■ N-ch Output Current

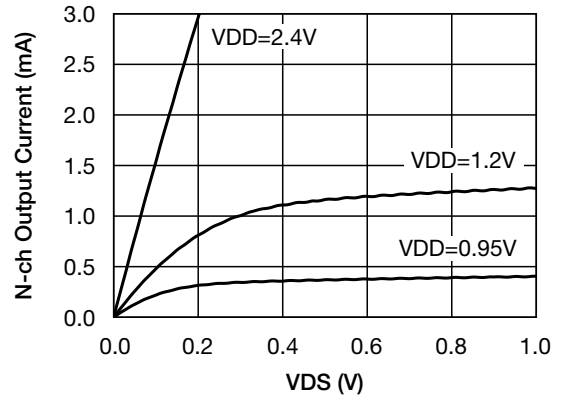

Note : \* These are typical characteristics.

• Any products mentioned in this catalog are subject to any modification in their appearance and others for improvements without prior notification.  
 • The details listed here are not a guarantee of the individual products at the time of ordering. When using the products, you will be asked to check their specifications.