

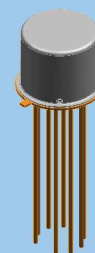

HIGH-SHOCK, HIGH-PERFORMANCE TO-5 RELAY DPDT



SERIES	RELAY TYPE
412K	DPDT High-Shock, Non-Latching Relay
422K	DPDT High-Shock, Magnetic-Latching Relay

DESCRIPTION

The TO-5 relay, originally conceived and developed by Teledyne, has become one of the industry standards for low-level switching from dry circuit to 1 ampere. Designed for highdensity PC board mounting, its small size and low coil power dissipation make the TO-5 relay one of the most versatile subminiature relays available.

The K Series high-shock TO-5 relays are designed to withstand shock levels up to 4000 g's, .5 millisecond duration. Special material selection and construction details provide assurance that critical elements of the relay structure and mechanism will not be permanently displaced or damaged as a result of extremely high g level shocks.

Typical applications:

- Commercial avionics aircraft control
- Commercial aircraft control systems
- Transportation systems (rail/truck)

By virtue of their inherently low intercontact capacitance and contact circuit losses, the K Series relays have proven to be excellent subminiature RF switches for applications with frequency ranges well into the UHF spectrum. A typical RF application for the TO-5 relay is in handheld radio transceivers, wherein the combined features of good RF performance, small size, low coil power dissipation and high reliability make it a preferred method of T-R switching (see Figure 1).

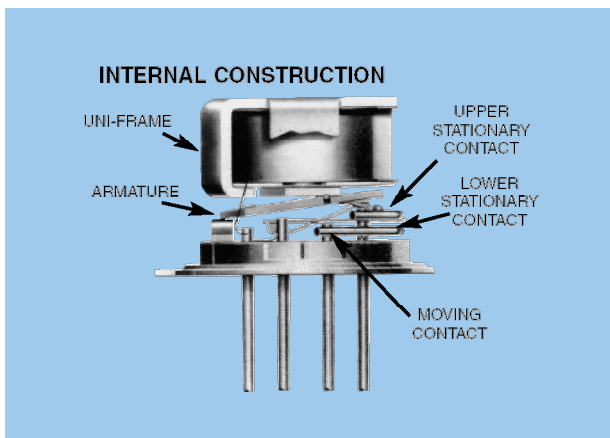

ENVIRONMENTAL AND PHYSICAL SPECIFICATIONS	
Temperature (Ambient)	-65°C to +125°C
Vibration (General Note 1)	30 g's 10 to 3000 Hz
Shock	General Note 1) 75 g's, 6ms half sine
	(General Note 4) 4000 g's, 0.5 msec. axial plane, half-sine 1000 g's, 0.5 msec side planes, half-sine
Acceleration	50 g's
Enclosure	Hermetically sealed
Weight	0.09 oz. (2.55g) max.

Series 412K/422K

Non-Latching, 1A
High Shock, High Performance



SERIES 412K GENERAL ELECTRICAL SPECIFICATIONS (-65°C to +125°C unless otherwise noted)

Contact Arrangement	2 Form C (DPDT)
Contact Resistance <i>Measured 1/8" below header</i>	High Level: 0.1Ω maximum before life; 0.2Ω max. after life at 1A/28Vdc
Contact Load Rating (DC) <i>(See Fig. 2 for other DC resistive voltage/current ratings)</i>	Resistive: 1A/28Vdc Inductive: 200mA/28Vdc (320 mH) Lamp: 100mA/28Vdc Low Level: 10 to 50μA/10 to 50mV
Contact Load Rating (AC)	Resistive: 250mA/115Vac, 60 and 400 Hz (Case not grounded) 100mA/115Vac, 60 and 400 Hz (Case grounded)
Contact Bounce	3.0 ms maximum
Contact Life Ratings	10,000,000 cycles (typical) at low level 1,000,000 cycles at 0.5A/28Vdc resistive 100,000 cycles min. at all other loads specified above
Contact Overload Rating	2A/28Vdc Resistive (100 cycles min.)
Contact Carry Rating	Contact Factory
Coil Operating Power	500mW typ. @ 25°C
Operate Time	2.0 msec max.
Release Time	412K: 1.5 msec max.; 412KD: 4.0 msec max.
Intercontact Capacitance	0.4 pf typical
Insulation Resistance	10,000 MΩ minimum, between mutually isolated terminals
Dielectric Strength	Atmospheric pressure: 500Vrms/60Hz; 70,000 ft.: 125Vrms/60Hz

DETAILED ELECTRICAL SPECIFICATIONS (-65°C to +125°C unless otherwise noted) (Note 3)

BASE PART NUMBERS (See full P/N example)			412K-5	412K-12	412K-26
Coil Voltage, Nominal (Vdc)	Nom.		5.0	12.0	26.5
	Max.		5.8	16.0	32.0
412K Coil Resistance <i>(Ohms ±10%, 25°C)</i>	412K		50	300	1350
422K Coil Resistance <i>(Ohms ±10%, 25°C)</i>	422K		61	500	2000
Pick-up Voltage (Vdc, Max.)	412K		4.3	10.0	21.0
Drop-out Voltage (Vdc)	412K	Min.	0.14	0.41	0.89
Set & Reset Voltage (Vdc)	422K	Max	3.5	9.0	18.0

SCHEMATIC DIAGRAMS

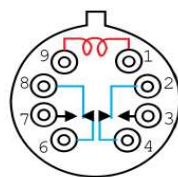

412K

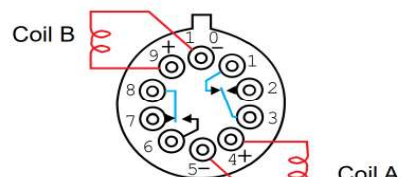

422K

SCHEMATICS ARE VIEWED FROM TERMINALS

**SERIES 412K
PERFORMANCE CURVES**

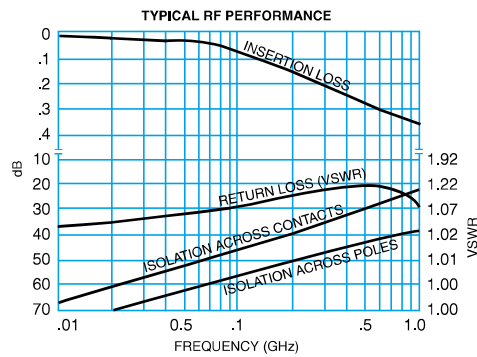

Figure 1

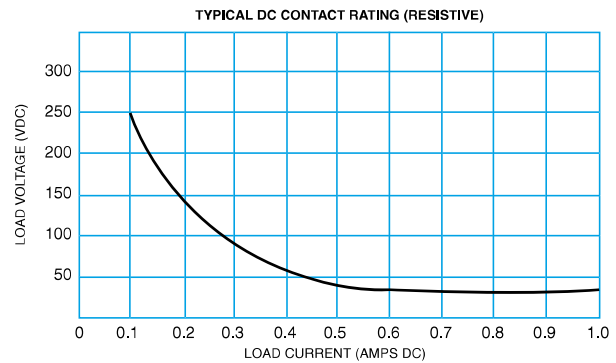
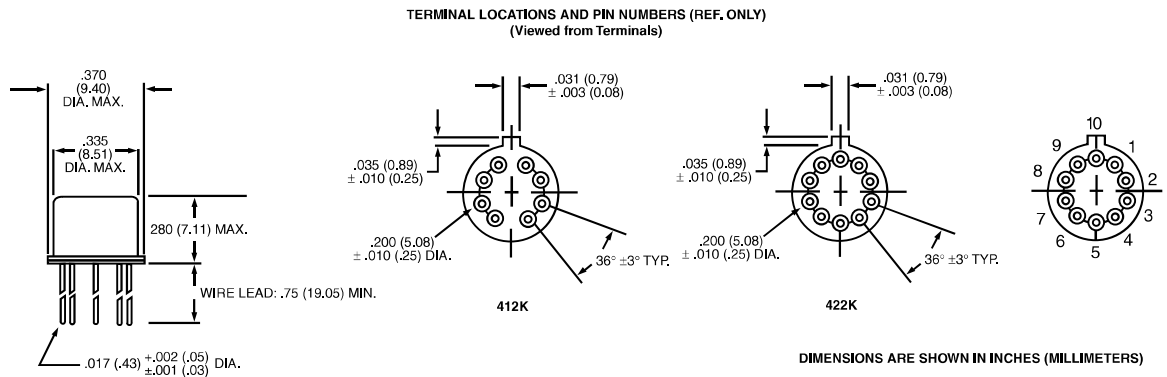
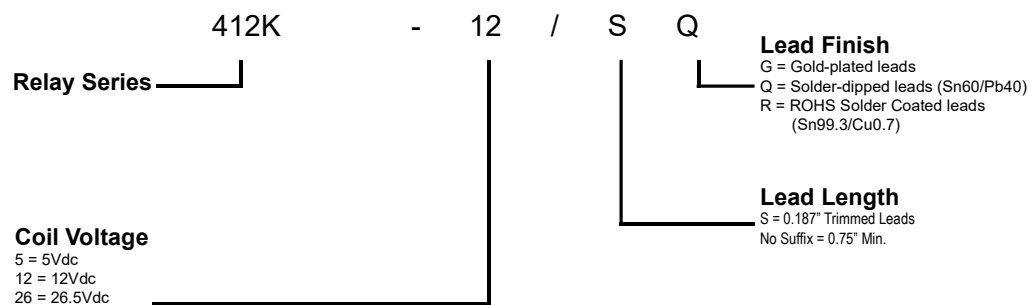

Figure 2

OUTLINE DIMENSIONS



Teledyne Part Numbering System for 412K Series



General Notes

1. Relay contacts will exhibit no chatter in excess of 10 µsec or transfer in excess of 1 µsec.
2. "Typical" characteristics are based on available data and are best estimates. No on-going verification tests are performed.
3. Unless otherwise specified, parameters are initial values.
4. Unless otherwise specified, relays will be supplied with either gold-plated or solder-coated leads.
5. The slash and characters appearing after the slash are not marked on the relay.
6. Screened HI-REL versions available. Contact factory.