

0,635mm EDGE MOUNT PAIR QMSS-DP-EM SERIES

SPECIFICATIONS

For complete specifications see www.samtec.com?QMSS-DP-EM

Insulator Material: Liquid Crystal Polymer
Terminal, Ground Plane & Shield Material: Phosphor Bronze
Plating: Au over 50µ" (1.27µm) Ni (Tin on Ground Plane Tails)
Current Rating: Testing Now!
Operating Temp: -55°C to +125°C

Note: Some lengths, styles and options are non-standard, non-returnable.

Mates with: QFSS

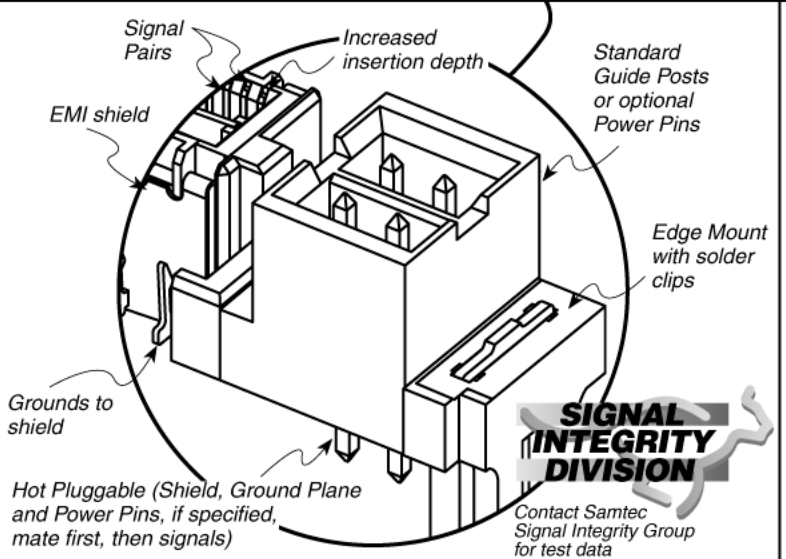

SIGNAL INTEGRITY DIVISION
 Contact Samtec Signal Integrity Group for test data

APPLICATION SPECIFIC OPTION

- 8 Power Pins/End Call Samtec.

Processing:

Max Processing Temp: 230°C for 60 seconds, or 260°C for 20 seconds 3x
Lead-Free Solderable: Yes
SMT Lead Coplanarity: (0,10mm) .004" max (016-048) (0,15mm) .006" max (064) lead coplanarity
Suggested PCB Layouts: For reference only. Go to www.samtec.com?QMSS-DP-EM for recommended PCB layout.

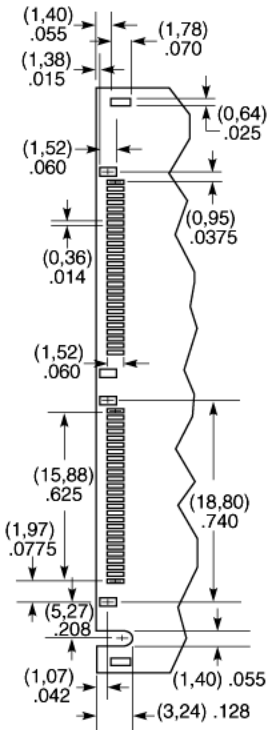

-016, -032, -048, -064
 (16 pairs per bank)

-H
 = 30µ" (0,76µm) Gold on Signal Pins, 10µ" (0,25µm) Gold on Shield and Ground Plane

-L
 = 10µ" (0,25µm) Gold on Signal Pins, Shield and Ground Plane

-PC4
 = 4 Power Pins/End (N/A with -064)

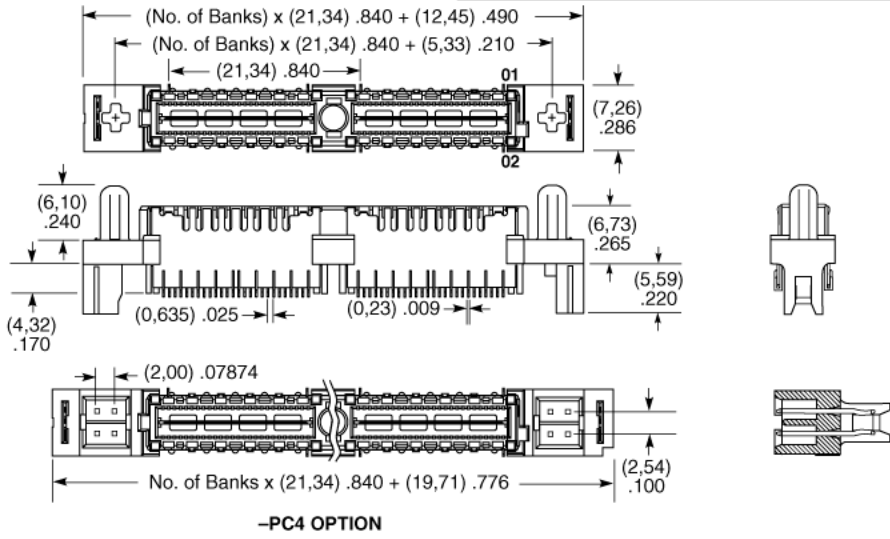

Due to technical progress, all designs, specifications and components are subject to change without notice.

WWW.SAMTEC.COM

SAMTEC USA • Tel: 1-800-SAMTEC-9 or 812-944-6733 • Fax: 812-948-5047
SAMTEC GERMANY • Tel: +49 (0) 89 / 89460-0 • Fax: +49 (0) 89 / 89460-299
SAMTEC JAPAN • Tel: 81-424-42-8318 • Fax: 81-424-42-8319
SAMTEC KOREA • Tel: 82-31-717-5685 • Fax: 82-31-717-5681
SAMTEC SILICON VALLEY • Tel: 408-395-5900 • Fax: 408-395-1520
SAMTEC FRANCE • Tel: 01 60 95 06 60 • Fax: 01 60 95 06 61
SAMTEC ISRAEL • Tel: 972-3-7526600 • Fax: 972-3-7526690
SAMTEC CHINA • Tel: 86-21-5385-4089 • Fax: 86-21-5385-4047
SAMTEC SOUTH AFRICA • Tel: 27 11 4528112 • Fax: 27 86 6714432
SAMTEC UK • Tel: 01236 739292 • Fax: 01236 727113
SAMTEC ITALY • Tel: 39 039 6890337 • Fax: 39 039 6890315
SAMTEC INDIA • Tel: 91 80 306 21 612 • Fax: 91 80 5152 8187
SAMTEC TAIWAN • Tel: 886 02 2698-3367 • Fax: 886 02 2698-1259
SAMTEC ANZ • Tel: 613 9512 7747 • Fax: 613 9512 7745