

Motor and Pump Protection Relays

MP8000

Motor Protection System



Patented

Description

The MP8000 series motor protection relay is designed to protect three-phase or single-phase motors with operating voltages of 90-690 V ac (use of external potential transformers can extend upper voltage range above 690 V ac). The MP8000 protects any motor drawing 0.5-1,000 full load amperes (external CTs are required above 100 A). The MP8000 series provides locked rotor, overload, overtemperature, and unbalance protection. Voltage-based protection elements are standard. These relays include inverse time-over current elements suitable for overload protection, and they also provide monitoring functions. The protection is unsurpassed by combining overload, voltage, phase loss and reversal, voltage and current imbalance, power monitoring, and underload in one package.

Operation

The relay operates as a fail-safe device. This means when the voltage is within the programmed limits, the relay will energize—the NO contact will close. When the unit loses power or senses a fault condition, the relay will de-energize and contacts will return to their original state. Once the unit has been installed and programmed, it is ready to operate. Once acceptable voltage is applied and the RD0 timer expires, the relay will energize—the NO contact will close.

Bluetooth/Ethernet Programming

This advanced motor protection electronic overload relay is fully programmable via Bluetooth* using an iPhone or Android smartphone/tablet with the Littelfuse App. The Bluetooth and Ethernet functions are easy to use, and arc-flash safety is increased because the app allows settings to be modified and real-time operational information viewed. The user is not required to open the control panel for viewing operational information and faults on the app. These relays also feature an Ethernet communications port that can be used to form an Ethernet Modbus TCP/IP or Ethernet/IP network. They can be remotely monitored and controlled from a PC, or SCADA system, and data logging through a PC with the optional MP8000 software or other software program using the MP8000 memory map. This capability allows for a simple cost-effective way to further enhance arc-flash safety.

Features & Benefits

FEATURES	BENEFITS
Bluetooth capability	Access through iPhone or Android smartphone
Ethernet communications port	Remote monitoring

Applications

- Conveyor systems
- HVAC equipment
- Saws and grinders
- Fan motors
- Almost any pumping application

*Bluetooth is a trademark of its respective owner.

Motor and Pump Protection Relays

MP8000

Specifications

Functional Characteristics

Frequency	50/60 Hz
TC- Overcurrent	Trip Class: Trip class 02-60 or linear

Output Characteristics

Output Contact Rating	
Control Relay	SPST - Form A
Auxiliary Relay	SPDT - Form C
Pilot Duty Rating	B300
General Purpose	5 A @ 240 V ac, 5 A @ 28 V dc (MP8010)

General Characteristics

Ambient Temperature Range	
Operating	-40 °C to 70 °C (-40 °F to 158 °F)
Storage	-40 °C to 85 °C (-40 °F to 185 °F)

Accuracy

Voltage	±1 % of reading ±0.5 V
Current	±2 % (2 to 100 amperes direct)
Timing	+/-0.5 % of setting +/- 1second
GF Current	±5 %

Repeatability

Voltage	±0.5 %
Current	±1 % (2 to 100 A direct)
Power Consumption	<5 W
Pollution Degree	3 (conformal coating standard)
Class of Protection	IP20
Relative Humidity	10–95 %, non-condensing per IEC 68-2-3
Terminal Torque (depluggable terminal blocks)	5.5 in.-lbs.
Terminal Torque (Earth Ground)	7.9 in.-lbs.

Standards Passed

Electrostatic Discharge (ESD)	IEC 61000-4-2, Level 3, 6 kV contact, 8 kV air
Radio Frequency Immunity (RFI), Conducted (RFI), Radiated	IEC 61000-4-6, Level 3 10 V/m IEC 61000-4-3, Level 3 10 V/m
Fast Transient Burst	IEC 61000-4-4, Level 3, 3.5 kV input power
Surge	IEC 61000-4-5, Level 3, 2 kV line-to-line; Level 4, 4 kV line-to-ground
FCC	Rating Part 15.107 for emissions, Part 15.247 for intentional radiators
Short Circuit Withstand Rating	100 kA symmetrical at 690 V ac
Hi-Potential Test	Meets UL 508 (2 x rated V +1000 V for 1 minute)
Maximum Conductor Size (with insulation)	0.63"
Dimensions	H 74.42 mm (2.93"); W 103.63 mm (4.08"); D 121.67 mm (4.79")
Weight	0.85 lbs (13.6 oz, 385.6 g)
Mounting Method	Surface mount (4 - #8 screws) or DIN-rail mount

Certification & Compliance

cULus	UL 60947, UL 1053, C22.2 (File #E68520)
CE	IEC 60947 Edition 5.2, IEC 60947-8

Motor and Pump Protection Relays

MP8000

Accessories

ZSCT Series Current Transformer

Used with Littelfuse relays to detect low levels of earth-leakage current.

ZSCT5-31, 31 mm (1.22")
ZSCT5-88, 88 mm (3.46")

Ordering Information

MODEL	LINE VOLTAGE	MOTOR FULL AMP RANGE	DESCRIPTION	CONTROL POWER INPUT
MP8000	90–690 V ac (use of external potential transformers can extend upper voltage range above 690 V ac)	0.5–1,000+ A (external CTs required above 100 A)	Provides remote wired communication via Ethernet Modbus TCP/IP or Ethernet/IP	85 – 264 VAC
MP8010	90–690 V ac (use of external potential transformers can extend upper voltage range above 690 V ac)	0.5–1,000+ A (external CTs required above 100 A)	Provides remote wired communication via Ethernet Modbus TCP/IP or Ethernet/IP	12 – 30 VDC

Protection Functions

- Overload/Overpower (49)
- Underload/Underpower (37P)
- Overcurrent (51)/Jam
- Undercurrent (37)
- Current Unbalance/Phase Loss (46)
- Phase Reversal (47)
- Overvoltage (59)
- Undervoltage (27)
- Voltage Unbalance (47)
- Rapid Cycling/Jog
- Contactor Failure
- Zero-Sequence Ground Fault (50G/N, 51G/N)
- PTC Motor Overtemperature (49)

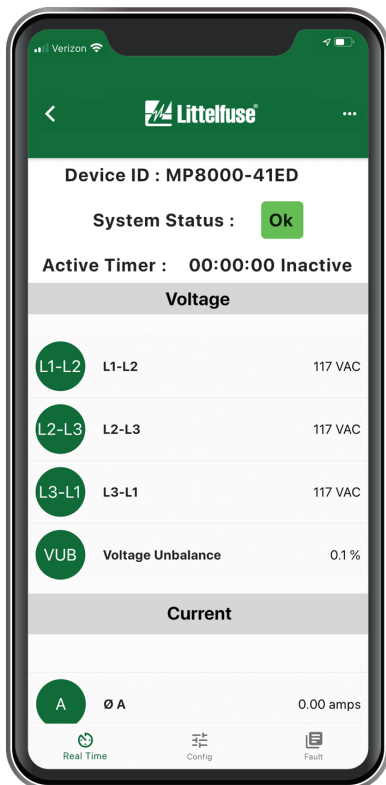

MP8000

Littelfuse App icon



Motor and Pump Protection Relays

MP8000

Dimensions Inches (mm)

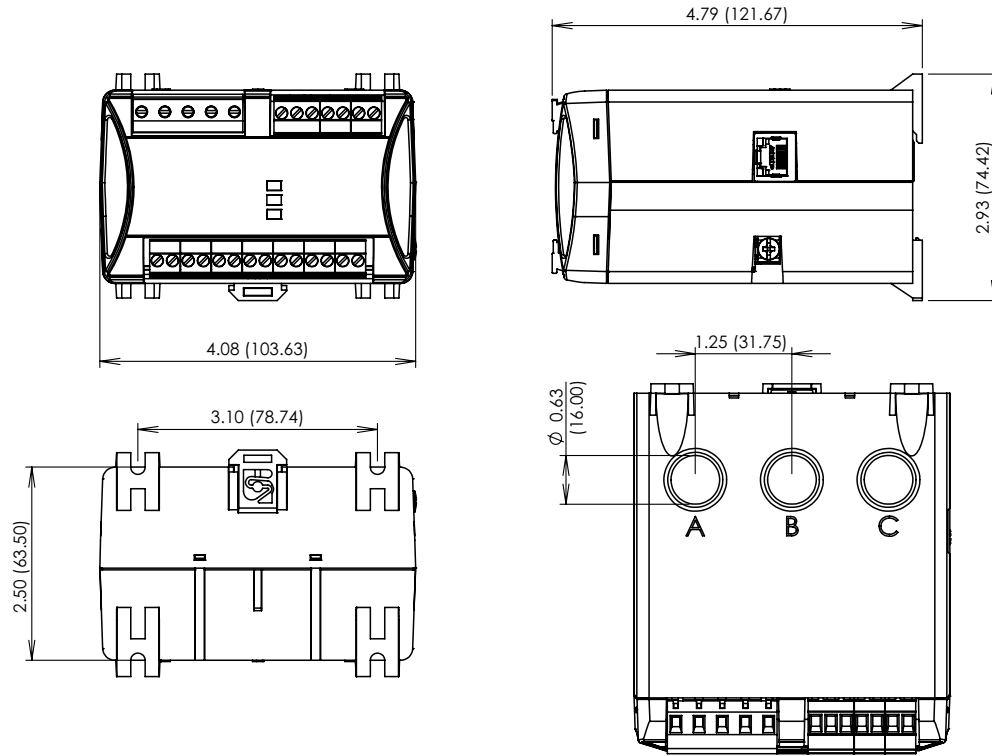

Motor and Pump Protection Relays

MP8000

Wiring Diagram

TYPICAL WIRING DIAGRAM FOR 3-PHASE

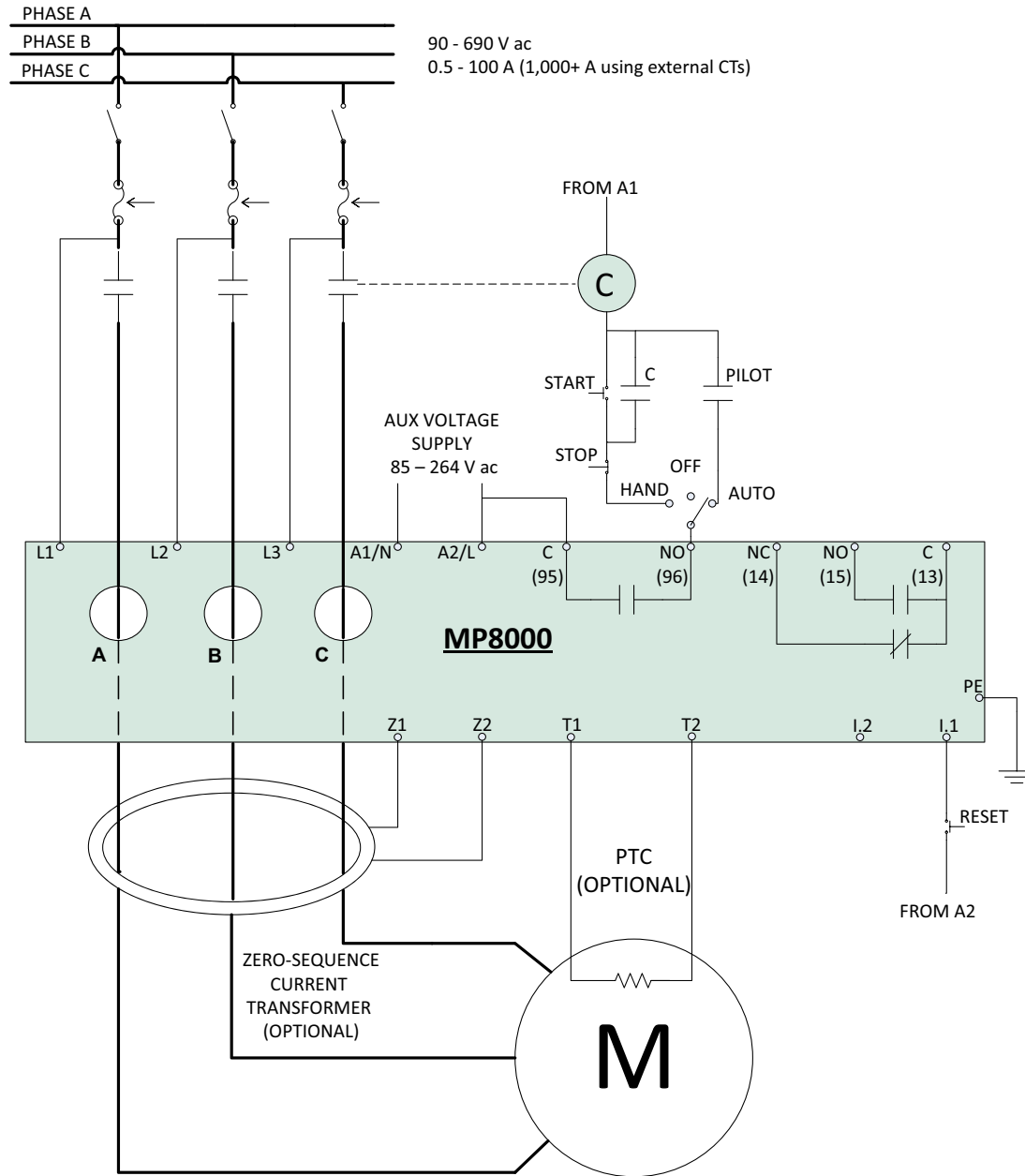

Motor and Pump Protection Relays

MP8000

Wiring Diagram

TYPICAL WIRING DIAGRAM FOR 3-PHASE

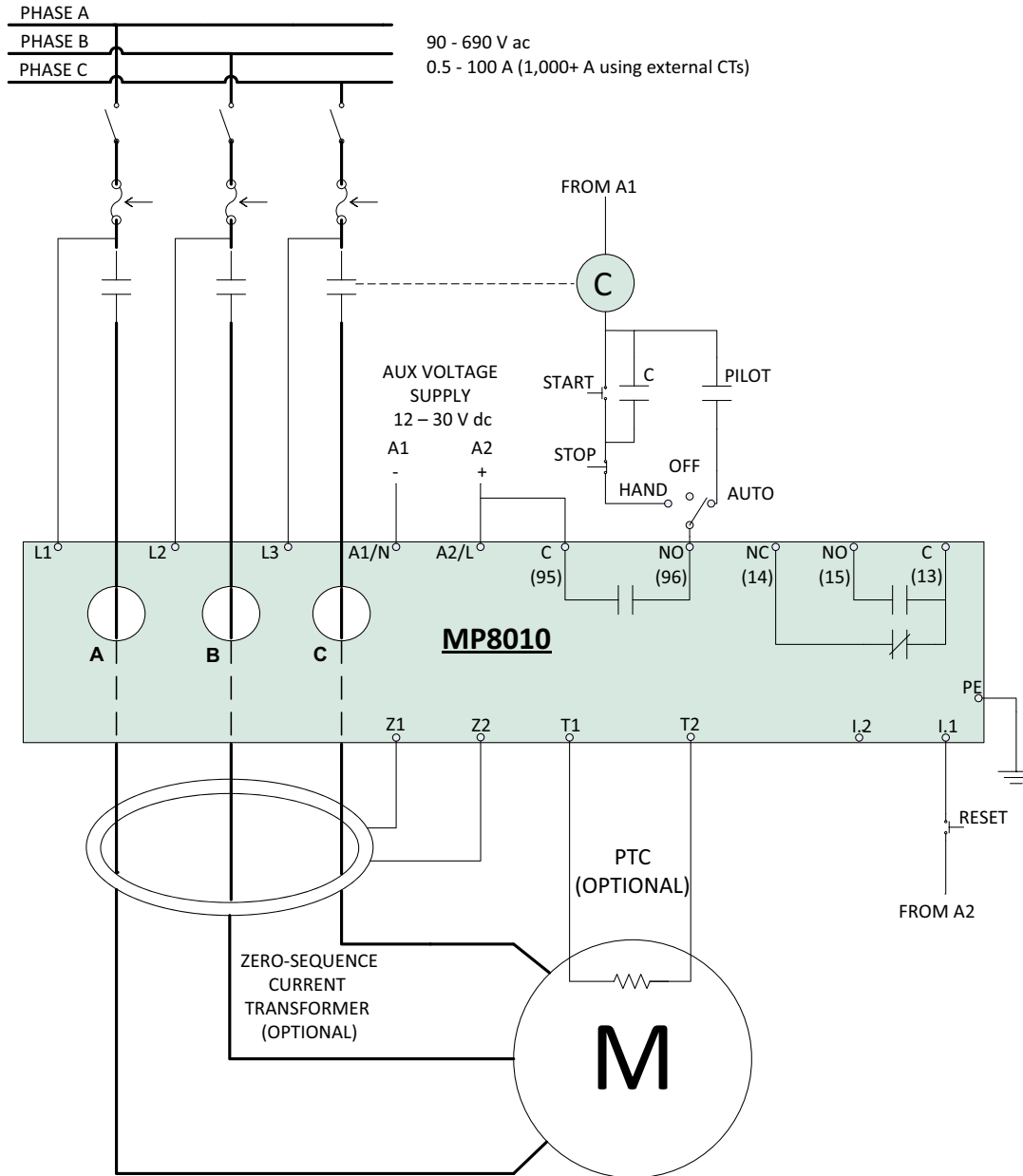

Disclaimer Notice – Information furnished is believed to be accurate and reliable. However, users should independently evaluate the suitability of and test each product selected for their own applications. Littelfuse products are not designed for, and may not be used in, all applications. Read complete Disclaimer Notice at www.littelfuse.com/product-disclaimer.