

FEATURES

- 18.1SPECint95, Estimates 12.3 SPECfp95 at 400 MHz (PC755)
- 15.7SPECint95, 9SPECfp95 at 350 MHz (PC745)
- 733 MIPS at 400 MHz (PC755) at 641 MIPS at 350 MHz (PC745)
- Selectable Bus Clock (12 CPU Bus Dividers up to 10x)
- P_D Typical 5.4W at 400 MHz, Full Operating Conditions
- Nap, Doze and Sleep Modes for Power Savings
- Superscalar (3 Instructions per Clock Cycle) Two Instruction + Branch
- 4 Beta Byte Virtual Memory, 4-GByte of Physical Memory
- 64-bit Data and 32-bit Address Bus Interface
- 32-KB Instruction and Data Cache
- Six Independent Execution Units
- Write-back and Write-through Operations
- f_{INT} max = 400 MHz
- f_{BUS} max = 100 MHz
- Voltage I/O 2.5V/3.3V; Voltage Int 2.0V

Description

This document is primarily concerned with the PC755; however, unless otherwise noted, all information here also applies to the PC745. The PC755 and PC745 are reduced instruction set computing (RISC) microprocessors that implement the PowerPC™ instruction set architecture.

This document describes pertinent physical characteristics of the PC755. For information on specific PC755 part numbers covered by this or other specifications, see [Table 11-1, “Ordering Information,” on page 60](#). For functional characteristics of the processor, refer to the *MPC750 RISC Microprocessor Family User’s Manual*.

To locate any published errata or updates for this document, refer to the website listed on the back cover of this document.

Screening

This product is manufactured in full compliance with:

- HiTCE CBGA According to e2v Standards
- CBGA + CI-CGA + FC-PBGA up Screenings Based upon e2v Standards
- Full Military Temperature Ranges ($T_C = -55^\circ\text{C}$, $T_J = +125^\circ\text{C}$)
- Industrial Temperature Ranges ($T_C = -40^\circ\text{C}$, $T_J = +110^\circ\text{C}$)
- Commercial Temperature ranges ($T_C = 0^\circ\text{C}$, $T_J = +105^\circ\text{C}$)

Whilst e2v technologies has taken care to ensure the accuracy of the information contained herein it accepts no responsibility for the consequences of any use thereof and also reserves the right to change the specification of goods without notice. e2v technologies accepts no liability beyond the set out in its standard conditions of sale in respect of infringement of third party patents arising from the use of devices in accordance with information contained herein.

e2v technologies (uk) limited, Waterhouse Lane, Chelmsford, Essex CM1 2QU United Kingdom Holding Company: e2v technologies plc

Telephone: +44 (0)1245 493493 Facsimile: +44 (0)1245 492492

Contact e2v by e-mail: enquiries@e2v.com or visit www.e2v.com for global sales and operations centres.

1. OVERVIEW

The PC755 is targeted for low-cost, low-power systems and supports the following power management features: doze, nap, sleep, and dynamic power management. The PC755 consists of a processor core and an internal L2 tag combined with a dedicated L2 cache interface and a 60x bus. The PC745 is identical to the PC755 except it does not support the L2 cache interface.

Figure 1-1 shows a block diagram of the PC755.

Figure 1-1. PC755 Block Diagram

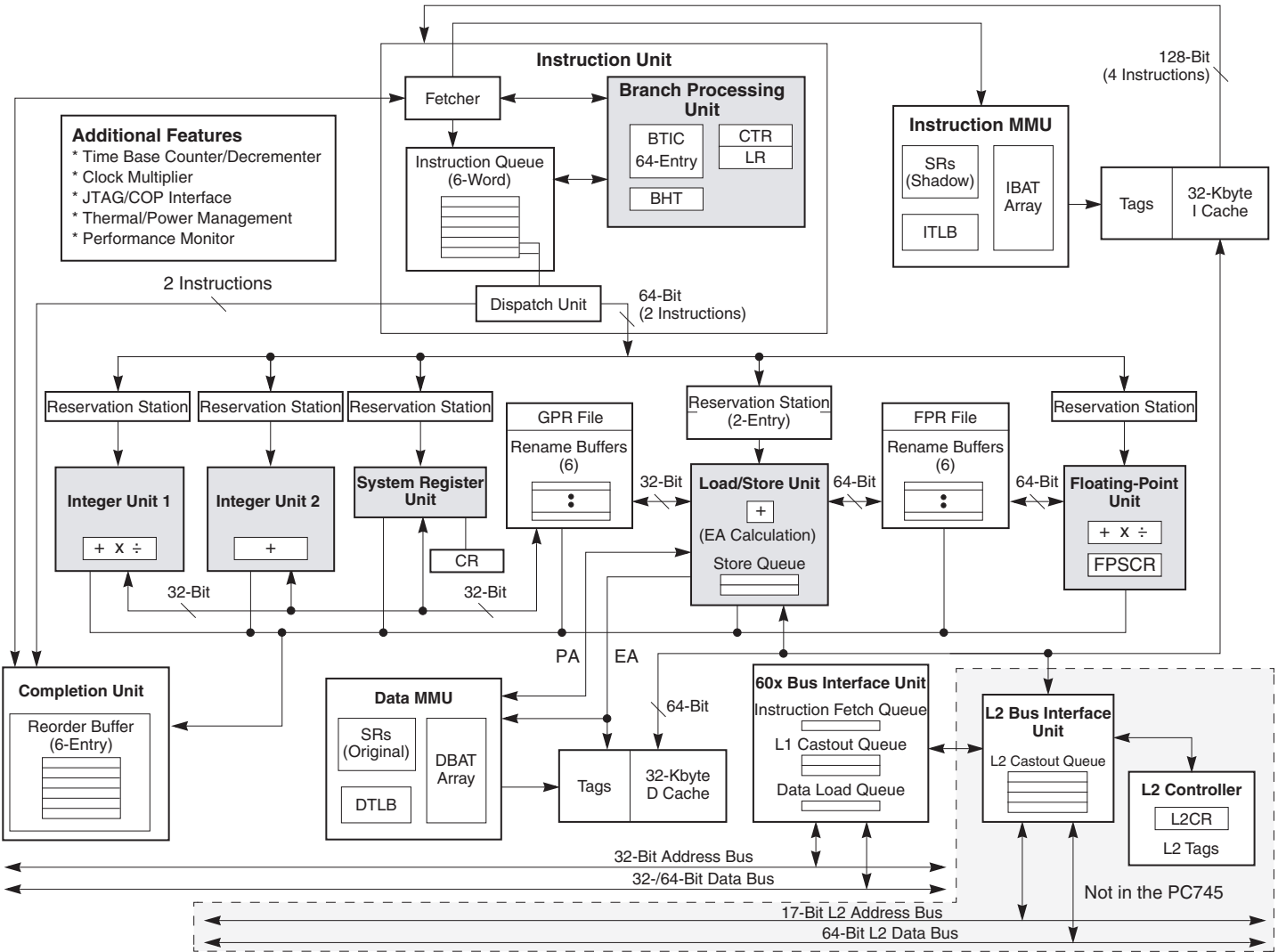

2. FEATURES

This section summarizes features of the PC755 implementation of the PowerPC architecture. Major features of the PC755 are as follows:

- Branch processing unit
 - Four instructions fetched per clock
 - One branch processed per cycle (plus resolving two speculations)
 - Up to one speculative stream in execution, one additional speculative stream in fetch
 - 512-entry branch history table (BHT) for dynamic prediction
 - 64-entry, four-way set-associative branch target instruction cache (BTIC) for eliminating branch delay slots
- Dispatch unit
 - Full hardware detection of dependencies (resolved in the execution units)
 - Dispatch two instructions to six independent units (system, branch, load/store, fixed-point unit 1, fixed-point unit 2, floating-point)
 - Serialization control (predispatch, postdispatch, execution serialization)
- Decode
 - Register file access
 - Forwarding control
 - Partial instruction decode
- Completion
 - Six-entry completion buffer
 - Instruction tracking and peak completion of two instructions per cycle
 - Completion of instructions in program order while supporting out-of-order instruction execution, completion serialization, and all instruction flow changes
- Fixed point units (FXUs) that share 32 GPRs for integer operands
 - Fixed Point Unit 1 (FXU1): multiply, divide, shift, rotate, arithmetic, logical
 - Fixed Point Unit 2 (FXU2): shift, rotate, arithmetic, logical
 - Single-cycle arithmetic, shifts, rotates, logical
 - Multiply and divide support (multi-cycle)
 - Early out multiply
- Floating-point unit and a 32-entry FPR file
 - Support for IEEE standard 754 single- and double-precision floating-point arithmetic
 - Hardware support for divide
 - Hardware support for denormalized numbers
 - Single-entry reservation station
 - Supports non-IEEE mode for time-critical operations
 - Three-cycle latency, one-cycle throughput, single-precision multiply-add
 - Three-cycle latency, one-cycle throughput, double-precision add

- Four-cycle latency, two-cycle throughput, double-precision multiply-add
- System unit
 - Executes CR logical instructions and miscellaneous system instructions
 - Special register transfer instructions
- Load/store unit
 - One-cycle load or store cache access (byte, half-word, word, double word)
 - Effective address generation
 - Hits under misses (one outstanding miss)
 - Single-cycle unaligned access within double-word boundary
 - Alignment, zero padding, sign extend for integer register file
 - Floating-point internal format conversion (alignment, normalization)
 - Sequencing for load/store multiples and string operations
 - Store gathering
 - Cache and TLB instructions
 - Big- and little-endian byte addressing supported
- Level 1 cache structure
 - 32K, 32-byte line, eight-way set-associative instruction cache (iL1)
 - 32K, 32-byte line, eight-way set-associative data cache (dL1)
 - Cache locking for both instruction and data caches, selectable by group of ways
 - Single-cycle cache access
 - Pseudo least-recently-used (PLRU) replacement
 - Copy-back or write-through data cache (on a page per page basis)
 - MEI data cache coherency maintained in hardware
 - Nonblocking instruction and data cache (one outstanding miss under hits)
 - No snooping of instruction cache
- Level 2 (L2) cache interface (not implemented on PC745)
 - Internal L2 cache controller and tags; external data SRAMs
 - 256K, 512K, and 1 Mbyte two-way set-associative L2 cache support
 - Copy-back or write-through data cache (on a page basis, or for all L2)
 - Instruction-only mode and data-only mode
 - 64-byte (256K/512K) or 128-byte (1M) sectored line size
 - Supports flow through (register-buffer) synchronous BurstRAMs, pipelined (register-register) synchronous BurstRAMs (3-1-1-1 or strobeless 4-1-1-1) and pipelined (register-register) late write synchronous BurstRAMs
 - L2 configurable to cache, private memory, or split cache/private memory
 - Core-to-L2 frequency divisors of $\div 1$, $\div 1.5$, $\div 2$, $\div 2.5$, and $\div 3$ supported
 - 64-bit data bus
 - Selectable interface voltages of 2.5 and 3.3 V

- Parity checking on both L2 address and data
- Memory management unit
 - 128-entry, two-way set-associative instruction TLB
 - 128-entry, two-way set-associative data TLB
 - Hardware reload for TLBs
 - Hardware or optional software tablewalk support
 - Eight instruction BATs and eight data BATs
 - Eight SPRGs, for assistance with software tablewalks
 - Virtual memory support for up to 4 exabytes (252) of virtual memory
 - Real memory support for up to 4 gigabytes (232) of physical memory
- Bus interface
 - Compatible with 60x processor interface
 - 32-bit address bus
 - 64-bit data bus, 32-bit mode selectable
 - Bus-to-core frequency multipliers of 2x, 3x, 3.5x, 4x, 4.5x, 5x, 5.5x, 6x, 6.5x, 7x, 7.5x, 8x, 10x supported
 - Selectable interface voltages of 2.5 and 3.3 V
 - Parity checking on both address and data buses
- Power management
 - Low-power design with thermal requirements very similar to PC740/PC750
 - Three static power saving modes: doze, nap, and sleep
 - Dynamic power management
- Integrated thermal management assist unit
 - On-chip thermal sensor and control logic
 - Thermal management interrupt for software regulation of junction temperature
- Testability
 - LSSD scan design
 - IEEE 1149.1 JTAG interface

3. GENERAL PARAMETERS

The following list provides a summary of the general parameters of the PC755:

Technology	0.22 μm CMOS, six-layer metal
Die size	6.61 mm \times 7.73 mm (51 mm ²)
Transistor count	6.75 million
Logic design	Fully-static
Packages	
PC745	Surface mount 255 Plastic Ball Grid Array (PBGA) Surface mount 255 Ceramic Ball Grid Array (Hi-TCE)
PC755	Surface mount 360 Plastic Ball Grid Array (PBGA) Surface mount 360 Ceramic Ball Grid Array (CI-CGA, CBGA, HiTCE)
Core power supply	2.0 V \pm 100 mV DC (nominal; some parts support core voltages down to 1.8 V; see Table 5-3 on page 9 for recommended operating conditions)
I/O power supply	2.5 V \pm 100 mV DC or 3.3 V \pm 165 mV DC (input thresholds are configuration pin selectable)

4. DETAILED SPECIFICATIONS

This specification describes the specific requirements for the microprocessor PC755, in compliance with e2v Grenoble standard screening.

4.1 Applicable Documents

- 1) MIL-STD-883: Test methods and procedures for electronics.
- 2) MIL-PRF-38535 appendix A: General specifications for microcircuits.

The microcircuits are in accordance with the applicable documents and as specified herein.

5. ELECTRICAL AND THERMAL CHARACTERISTICS

This section provides the AC and DC electrical specifications and thermal characteristics for the PC755.

5.1 DC Electrical Characteristics

Table 5-1 through Table 5-5 on page 11 describe the PC755 DC electrical characteristics. Table 5-1 provides the absolute maximum ratings.

Table 5-1. Absolute Maximum Ratings⁽¹⁾

Characteristic	Symbol	Maximum Value	Unit	Notes
Core supply voltage	V_{DD}	-0.3 to 2.5	V	(4)
PLL supply voltage	AV_{DD}	-0.3 to 2.5	V	(4)
L2 DLL supply voltage	$L2AV_{DD}$	-0.3 to 2.5	V	(4)
Processor bus supply voltage	OV_{DD}	-0.3 to 3.6	V	(3)
L2 bus supply voltage	$L2OV_{DD}$	-0.3 to 3.6	V	(3)
Input voltage	Processor bus	V_{IN}	-0.3 to $OV_{DD} + 0.3V$	(2)(5)
	L2 bus	V_{IN}	-0.3 to $L2OV_{DD} + 0.3V$	(2)(5)
	JTAG signals	V_{IN}	-0.3 to 3.6	
Storage temperature range	T_{STG}	-65/+150	°C	

- Notes:
1. Functional and tested operating conditions are given in “Recommended Operating Conditions⁽¹⁾” on page 9. Absolute maximum ratings are stress ratings only, and functional operation at the maximums is not guaranteed. Stresses beyond those listed may affect device reliability or cause permanent damage to the device.
 2. Caution: V_{IN} must not exceed OV_{DD} or $L2OV_{DD}$ by more than 0.3V at any time including during power-on reset.
 3. Caution: $L2OV_{DD}/OV_{DD}$ must not exceed $V_{DD}/AV_{DD}/L2AV_{DD}$ by more than 1.6V during normal operation. During power-on reset and power-down sequences, $L2OV_{DD}/OV_{DD}$ may exceed $V_{DD}/AV_{DD}/L2AV_{DD}$ by up to 3.3V for up to 20 ms, or by 2.5V for up to 40 ms. Excursions beyond 3.3V or 40 ms are not supported.
 4. Caution: $V_{DD}/AV_{DD}/L2AV_{DD}$ must not exceed $L2OV_{DD}/OV_{DD}$ by more than 0.4V during normal operation. During power-on reset and power-down sequences, $V_{DD}/AV_{DD}/L2AV_{DD}$ may exceed $L2OV_{DD}/OV_{DD}$ by up to 1.0V for up to 20 ms, or by 0.7V for up to 40 ms. Excursions beyond 1.0V or 40 ms are not supported.
 5. This is a DC specifications only. V_{IN} may overshoot/undershoot to a voltage and for a maximum duration as shown in Figure 5-1.

Figure 5-1 shows the allowable overshoot and undershoot voltage on the PC755.

Figure 5-1. Overshoot/Undershoot Voltage

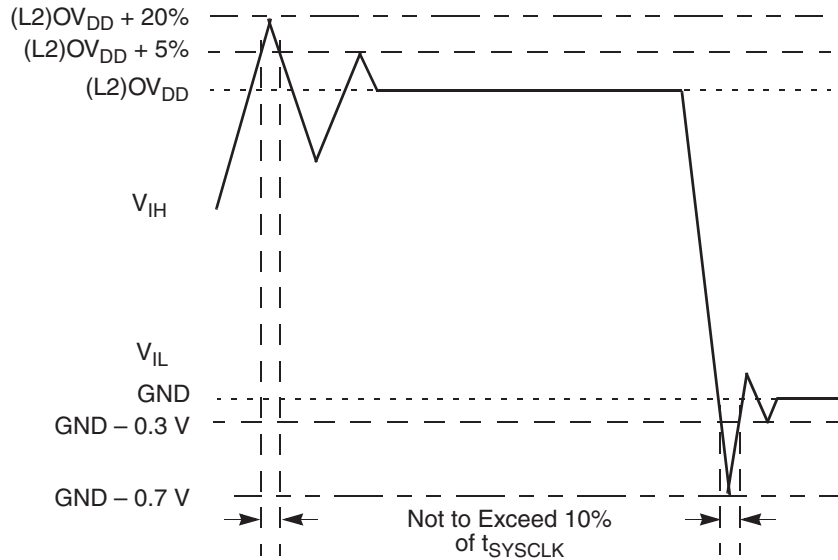

The PC755 provides several I/O voltages to support both compatibility with existing systems and migration to future systems. The PC755 core voltage must always be provided at nominal 2.0 V (see Table 5-3 for actual recommended core voltage). Voltage to the L2 I/Os and processor interface I/Os are provided through separate sets of supply pins and may be provided at the voltages shown in Table 5-2. The input voltage threshold for each bus is selected by sampling the state of the voltage select pins BVSEL and L2VSEL during operation. These signals must remain stable during part operation and cannot change. The output voltage will swing from GND to the maximum voltage applied to the OV_{DD} or $L2OV_{DD}$ power pins.

Table 5-2 describes the input threshold voltage setting.

Table 5-2. Input Threshold Voltage Setting

Part Revision	BVSEL Signal	Processor Bus Interface Voltage	L2VSEL Signal	L2 Bus Interface Voltage
E	0	Not Available	0	Not Available
	1	2.5V/3.3V	1	2.5V/3.3V

Caution: The input threshold selection must agree with the $OV_{DD}/L2OV_{DD}$ voltages supplied.

Note: The input threshold settings above are different for all revisions prior to Rev. 2.8 (Rev. E).

For more information, contact your local e2v sales office.

Table 5-3 provides the recommended operating conditions for the PC755.

Table 5-3. Recommended Operating Conditions⁽¹⁾

Characteristic		Symbol	Recommended Value						Unit	Notes
			300 MHz, 350 MHz		400 MHz		400 MHz			
			Min	Max	Min	Max	Min	Max		
Core supply voltage		V_{DD}	1.80	2.10	1.90	2.10	2.00	2.10	V	(3)
PLL supply voltage		AV_{DD}	1.80	2.10	1.90	2.10	2.00	2.10	V	(3)
L2 DLL supply voltage		$L2AV_{DD}$	1.80	2.10	1.90	2.10	2.00	2.10	V	(3)
Processor bus supply voltage	BVSEL = 1	OV_{DD}	2.375	2.625	2.375	2.625	2.375	2.625	V	(2)(4)
			3.135	3.465	3.135	3.465	3.135	3.465		(5)
L2 bus supply voltage	L2VSEL = 1	$L2OV_{DD}$	2.375	2.625	2.375	2.625	2.375	2.625	V	(2)(4)
			3.135	3.465	3.135	3.465	3.135	3.465		(5)
Input voltage	Processor bus	V_{IN}	GND	OV_{DD}	GND	OV_{DD}	GND	OV_{DD}	V	
	L2 Bus	V_{IN}	GND	$L2OV_{DD}$	GND	$L2OV_{DD}$	GND	$L2OV_{DD}$	V	
	JTAG signals	V_{IN}	GND	OV_{DD}	GND	OV_{DD}	GND	OV_{DD}	V	
Die-junction temperature	Military temperature range		$T_C = -55$	$T_J = 125$			$T_C = -55$	$T_J = 125$	°C	
	Industrial temperature range		$T_C = -40$	$T_J = 110$	$T_C = -40$	$T_J = 110$			°C	
	Commercial temperature range		$T_J = 0$	$T_J = 105$	$T_J = 0$	$T_J = 105$			°C	

- Notes:
1. These are the recommended and tested operating conditions. Proper device operation outside of these conditions is not guaranteed.
 2. Revisions prior to Rev. 2.8 (Rev. E) offered different I/O voltage support.
 3. 2.0V nominal.
 4. 2.5V nominal.
 5. 3.3V nominal.

Table 5-4 provides the DC electrical characteristics for the PC755.

Table 5-4. DC Electrical Specifications at Recommended Operating Conditions (see Table 5-3 on page 9)

Characteristic	Nominal bus Voltage ⁽¹⁾	Symbol	Min	Max	Unit	Notes
Input high voltage (all inputs except SYSCLK)	2.5	V_{IH}	1.6	$(L2)OV_{DD} + 0.3$	V	(2)(3)
	3.3	V_{IH}	2.0	$(L2)OV_{DD} + 0.3$	V	(2)(3)
Input low voltage (all inputs except SYSCLK)	2.5	V_{IL}	-0.3	0.6	V	(2)
	3.3	V_{IL}	-0.3	0.8	V	
SYSCLK input high voltage	2.5	KV_{IH}	1.8	$OV_{DD} + 0.3$	V	
	3.3	KV_{IH}	2.4	$OV_{DD} + 0.3$	V	
SYSCLK input low voltage	2.5	KV_{IL}	-0.3	0.4	V	
	3.3	KV_{IL}	-0.3	0.4	V	
Input leakage current, $V_{IN} = L2OV_{DD}/OV_{DD}$		I_{in}	-	10	μA	(2)(3)
High-Z (off-state) leakage current, $V_{IN} = L2OV_{DD}/OV_{DD}$		I_{TSL}	-	10	μA	(2)(3)(5)
Output high voltage, $I_{OH} = -6$ mA	2.5	V_{OH}	1.7	-	V	
	3.3	V_{OH}	2.4	-	V	
Output low voltage, $I_{OL} = 6$ mA	2.5	V_{OL}	-	0.45	V	
	3.3	V_{OL}	-	0.4	V	
Capacitance, $V_{IN} = 0V$, $f = 1$ MHz		C_{in}	-	5.0	pF	(3)(4)

- Notes:
1. Nominal voltages; See "Recommended Operating Conditions⁽¹⁾" on page 9.
 2. For processor bus signals, the reference is OV_{DD} while $L2OV_{DD}$ is the reference for the L2 bus signals.
 3. Excludes test signals (LSSD_MODE, L1_TSTCLK, L2_TSTCLK) and IEEE 1149.1 boundary scan (JTAG) signals.
 4. Capacitance is periodically sampled rather than 100% tested.
 5. The leakage is measured for nominal OV_{DD} and V_{DD} , or both OV_{DD} and V_{DD} must vary in the same direction (for example, both OV_{DD} and V_{DD} vary by either +5% or -5%).

Table 5-5 provides the power consumption for the PC755.

Table 5-5. Power Consumption for PC755

	Processor (CPU) Frequency			Unit	Notes
	300 MHz	350 MHz	400 MHz		
Full-Power Mode					
Typical	3.1	3.6	5.4	W	(1)(3)(4)
Maximum	4.5	6.0	8.0	W	(1)(2)
Doze Mode					
Maximum	1.8	2.0	2.3	W	(1)(2)
Nap Mode					
Maximum	1.0	1.0	1.0	W	(1)(2)(4)
Sleep Mode					
Maximum	550	550	550	mW	(1)(2)(4)
Sleep Mode (PLL and DLL Disabled)					
Maximum	510	510	510	mW	(1)(2)

- Notes:
1. These values apply for all valid processor bus and L2 bus ratios. The values do not include I/O supply power (OV_{DD} and $L2OV_{DD}$) or PLL/DLL supply power (AV_{DD} and $L2AV_{DD}$). OV_{DD} and $L2OV_{DD}$ power is system dependent, but is typically < 10% of V_{DD} power. Worst case power consumption for $AV_{DD} = 15$ mW and $L2AV_{DD} = 15$ mW.
 2. Maximum power is measured at nominal V_{DD} (see “Recommended Operating Conditions⁽¹⁾” on page 9) while running an entirely cache-resident, contrived sequence of instructions which keep the execution units maximally busy.
 3. Typical power is an average value measured at the nominal recommended V_{DD} (see “Recommended Operating Conditions⁽¹⁾”) and 65°C in a system while running a typical code sequence.
 4. Not 100% tested. Characterized and periodically sampled.

5.2 Thermal Characteristics

Table 5-6. Package Thermal Characteristics⁽⁶⁾

Characteristic	Symbol	Value			Unit	Notes
		PC755 CBGA	PC755 PBGA	PC745 PBGA		
Junction-to-ambient thermal resistance, natural convection	$R_{\theta JA}$	24	31	34	°C/W	(1)(2)
Junction-to-ambient thermal resistance, natural convection, four-layer (2s2p) board	$R_{\theta JMA}$	17	25	26	°C/W	(1)(3)
Junction-to-ambient thermal resistance, 200 ft./min. airflow, single-layer (1s) board	$R_{\theta JMA}$	18	25	27	°C/W	(1)(3)
Junction-to-ambient thermal resistance, 200 ft./min. airflow, four-layer (2s2p) board	$R_{\theta JMA}$	14	21	22	°C/W	(1)(3)
Junction-to-board thermal resistance	$R_{\theta JB}$	8	17	17	°C/W	(4)
Junction-to-case thermal resistance	$R_{\theta JC}$	< 0.1	< 0.1	< 0.1	°C/W	(5)

- Notes:
1. Junction temperature is a function of on-chip power dissipation, package thermal resistance, mounting site (board) temperature, ambient temperature, air flow, power dissipation of other components on the board, and board thermal resistance.
 2. Per SEMI G38-87 and JEDEC JESD51-2 with the single layer board horizontal.

3. Per JEDEC JESD51-6 with the board horizontal.
4. Thermal resistance between the die and the printed circuit board per JEDEC JESD51-8. Board temperature is measured on the top surface of the board near the package.
5. Thermal resistance between the die and the case top surface as measured by the cold plate method (MIL SPEC-883 Method 1012.1) with the calculated case temperature. The actual value of $R_{\theta JC}$ for the part is less than 0.1°C/W.
6. Refer to [Section 9.8 on page 54](#) for more details about thermal management.

[Table 5-7](#) provides the package thermal characteristics for the PC755, HiTCE.

Table 5-7. Package Thermal Characteristics for HiTCE Package

Characteristic	Symbol	Value		Unit
		PC755 HiTCE	PC745 HiTCE	
Junction-to-bottom of balls ⁽¹⁾	$R_{\theta J}$	6.8	6.5	°C/W
Junction-to-ambient thermal resistance, natural convection, four-layer (2s2p) board	$R_{\theta JMA}$	20.7 ⁽¹⁾⁽²⁾	20.9 ⁽¹⁾⁽⁴⁾	°C/W
Junction to board thermal resistance	$R_{\theta JB}$	11.0	10.2 ⁽³⁾	°C/W

- Notes:
1. Simulation, no convection air flow.
 2. Per JEDEC JESD51-6 with the board horizontal.
 3. Per JEDEC JESD51-8
 4. Per JEDEC JESD51-2 with the board horizontal.

Table 5-8. Package Thermal Characteristics for CI-CGA

Characteristic	Symbol	Value	Unit
		PC755 CI-CGA	
Junction to board thermal resistance	$R_{\theta JB}$	8.42	°C/W

The PC755 incorporates a thermal management assist unit (TAU) composed of a thermal sensor, digital-to-analog converter, comparator, control logic, and dedicated special-purpose registers (SPRs). See the PC750 RISC Microprocessor Family User’s Manual for more information on the use of this feature. Specifications for the thermal sensor portion of the TAU are found in [Table 5-9](#).

Table 5-9. Thermal Sensor Specifications at Recommended Operating Conditions (see [Table 5-3 on page 9](#))

Characteristic	Min	Max	Unit	Notes
Temperature range	0	127	°C	(1)
Comparator settling time	20	–	µs	(2)(3)
Resolution	4	–	°C	(3)
Accuracy	–12	+12	°C	(3)

- Notes:
1. The temperature is the junction temperature of the die. The thermal assist unit’s raw output does not indicate an absolute temperature, but must be interpreted by software to derive the absolute junction temperature. For information about the use and calibration of the TAU, see *Freescale Application Note AN1800/D, “Programming the Thermal Assist Unit in the PC750 Microprocessor”*.
 2. The comparator settling time value must be converted into the number of CPU clocks that need to be written into the THRM3 SPR.
 3. Guaranteed by design and characterization.

5.3 AC Electrical Characteristics

This section provides the AC electrical characteristics for the PC755. After fabrication, functional parts are sorted by maximum processor core frequency as shown in [Section 5.3.1 "Clock AC Specifications" on page 13](#) and tested for conformance to the AC specifications for that frequency. The processor core frequency is determined by the bus (SYSCLK) frequency and the settings of the PLL_CFG[0:3] signals. Parts are sold by maximum processor core frequency; see [Section 11-1 "Ordering Information" on page 60](#).

5.3.1 Clock AC Specifications

[Table 5-10](#) provides the clock AC timing specifications as defined in [Figure 5-2](#).

Table 5-10. Clock AC Timing Specifications at Recommended Operating Conditions (See [Table 5-3 on page 9](#))

Characteristic	Symbol	Maximum Processor Core Frequency						Unit	Notes
		300 MHz		350 MHz		400 MHz			
		Min	Max	Min	Max	Min	Max		
Processor frequency	f_{core}	200	300	200	350	200	400	MHz	(1)
VCO frequency	f_{VCO}	400	600	400	700	400	800	MHz	(1)
SYSCLK frequency	f_{SYSCLK}	25	100	25	100	25	100	MHz	(1)
SYSCLK cycle time	t_{SYSCLK}	10	40	10	40	10	40	ns	
SYSCLK rise and fall time	$t_{\text{KR}}, t_{\text{KF}}$	–	2.0	–	2.0	–	2.0	ns	(2)
	$t_{\text{KR}}, t_{\text{KF}}$	–	1.4	–	1.4	–	1.4	ns	(2)
SYSCLK duty cycle measured at $OV_{\text{DD}}/2$	$t_{\text{KHKL}}/t_{\text{SYSCLK}}$	40	60	40	60	40	60	%	(3)
SYSCLK jitter		–	±150	–	±150	–	±150	ps	(3)(4)
Internal PLL relock time		–	100	–	100	–	100	µs	(3)(5)

- Notes:
- Caution:** The SYSCLK frequency and PLL_CFG[0:3] settings must be chosen such that the resulting SYSCLK (bus) frequency, CPU (core) frequency, and PLL (VCO) frequency do not exceed their respective maximum or minimum operating frequencies. Refer to the PLL_CFG[0:3] signal description in [Table 9-1 on page 46](#), for valid PLL_CFG[0:3] settings.
 - Rise and fall times measurements are now specified in terms of slew rates, rather than time to account for selectable I/O bus interface levels. The minimum slew rate of 1 V/ns is equivalent to a 2 ns maximum rise/fall time measured at 0.4 and 2.4 V ($OV_{\text{DD}} = 3.3$ V) or a rise/fall time of 1 ns measured at 0.4 and 1.8 V ($OV_{\text{DD}} = 2.5$ V).
 - Timing is guaranteed by design and characterization.
 - This represents total input jitter—short term and long term combined—and is guaranteed by design.
 - Relock timing is guaranteed by design and characterization. PLL-relock time is the maximum amount of time required for PLL lock after a stable V_{DD} and SYSCLK are reached during the power-on reset sequence. This specification also applies when the PLL has been disabled and subsequently re-enabled during sleep mode. Also note that HRESET must be held asserted for a minimum of 255 bus clocks after the PLL-relock time during the power-on reset sequence.

Figure 5-2 provides the SYSCLK input timing diagram.

Figure 5-2. SYSCLK Input Timing Diagram

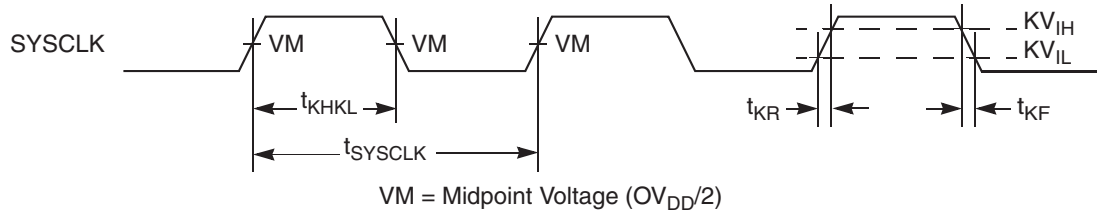

5.3.2 Processor Bus AC Specifications

Table 5-11 provides the processor bus AC timing specifications for the PC755 as defined in Figure 5-3 and Figure 5-5. Timing specifications for the L2 bus are provided in Section 5.3.3 "L2 Clock AC Specifications" on page 16.

Table 5-11. Processor Bus Mode Selection AC Timing Specifications⁽¹⁾ At Recommended Operating Conditions (See Table 5-3)

Parameter	Symbol ⁽²⁾	All Speed Grades		Unit	Notes
		Min	Max		
Mode select input setup to HRESET	t_{MVRH}	8	–	t_{SYSClk}	(3)(4)(5)(6)(7)
HRESET to mode select input hold	t_{MXRH}	0	–	ns	(3)(4)(6)(7)(8)

- Notes:
- All input specifications are measured from the midpoint of the signal in question to the midpoint of the rising edge of the input SYSCLK. All output specifications are measured from the midpoint of the rising edge of SYSCLK to the midpoint of the signal in question. All output timings assume a purely resistive 50Ω load (see Figure 5-4). Input and output timings are measured at the pin; time-of-flight delays must be added for trace lengths, vias, and connectors in the system.
 - The symbology used for timing specifications herein follows the pattern of $t_{(signal)(state)(reference)(state)}$ for inputs and $t_{(reference)(state)(signal)(state)}$ for outputs. For example, t_{IVKH} symbolizes the time input signals (I) reach the valid state (V) relative to the SYSCLK reference (K) going to the high (H) state or input setup time. And $t_{KH OV}$ symbolizes the time from SYSCLK (K) going high (H) until outputs (O) are valid (V) or output valid time. Input hold time can be read as the time that the input signal (I) went invalid (X) with respect to the rising clock edge (KH)—note the position of the reference and its state for inputs—and output hold time can be read as the time from the rising edge (KH) until the output went invalid (OX).
 - The setup and hold time is with respect to the rising edge of HRESET (see Figure 5-3).
 - This specification is for configuration mode select only. Also note that the HRESET must be held asserted for a minimum of 255 bus clocks after the PLL-relock time during the power-on reset sequence.
 - t_{sysclk} is the period of the external clock (SYSCLK) in ns. The numbers given in the table must be multiplied by the period of SYSCLK to compute the actual time duration (in ns) of the parameter in question.
 - Mode select signals are BVSEL, L2VSEL, PLL_CFG[0:3], and TLBISYNC.
 - Guaranteed by design and characterization.
 - Bus mode select pins must remain stable during operation. Changing the logic states of BVSEL or L2VSEL during operation will cause the bus mode voltage selection to change. Changing the logic states of the PLL_CFG pins during operation will cause the PLL division ratio selection to change. Both of these conditions are considered outside the specification and are not supported. Once HRESET is negated the states of the bus mode selection pins must remain stable.

Figure 5-3 provides the mode select input timing diagram for the PC755.

Figure 5-3. Mode Input Timing Diagram

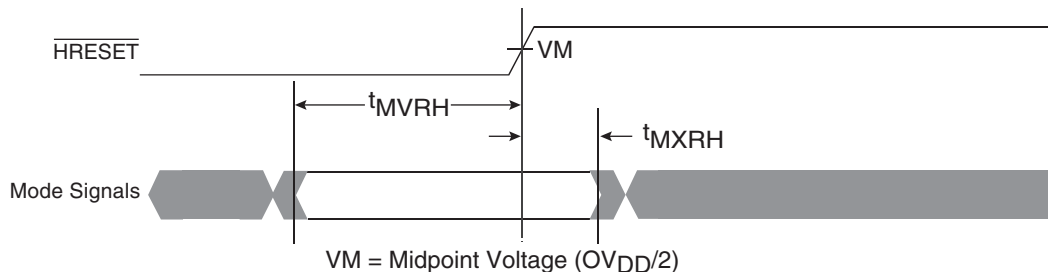

Figure 5-4 provides the AC test load for the PC755.

Figure 5-4. AC Test Load

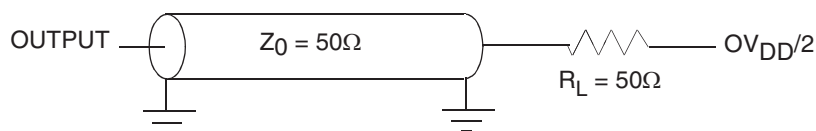

Table 5-12. Processor Bus AC Timing Specifications⁽¹⁾ at Recommended Operating Conditions (see Table 5-3 on page 9)

Parameter	Symbols	All Speed Grades		Unit	Notes
		Min	Max		
Setup times: All inputs	t_{IVKH}	2.5	–	ns	
Input hold times: $\overline{TLBISYNC}$, \overline{MCP} , \overline{SMI}	t_{IXKH}	0.6	–	ns	(6)
Input hold times: All Inputs, except $\overline{TLBISYNC}$, \overline{MCP} , \overline{SMI}	t_{IXKH}	0.2	–	ns	(6)
Valid times: All outputs	t_{KHOV}	–	4.1	ns	
Output hold times: All outputs	t_{KHOX}	1	–	ns	
SYSCLK to output enable	t_{KHOE}	0.5	–	ns	(2)
SYSCLK to output high impedance (all except \overline{ABB} , \overline{ARTRY} , \overline{DBB})	t_{KHOZ}	–	6.0	ns	(2)
SYSCLK to \overline{ABB} , \overline{DBB} high impedance after precharge	t_{KHABPZ}	–	1.0	t_{SYSCLK}	(2)(3)(4)
Maximum delay to \overline{ARTRY} precharge	t_{KHARP}	–	1	t_{SYSCLK}	(2)(3)(5)
SYSCLK to \overline{ARTRY} high impedance after precharge	t_{KHARPZ}	–	2	t_{SYSCLK}	(2)(3)(5)

- Notes:
- Revisions prior to Rev. 2.8 (Rev. E) were limited in performance and did not conform to this specification. For more information, refer to Section "Table 11-1 provides the e2v part numbering nomenclature for the PC755 and PC745 devices fully addressed by this document." on page 60.
 - Guaranteed by design and characterization.
 - t_{sysclk} is the period of the external clock (SYSCLK) in ns. The numbers given in the table must be multiplied by the period of SYSCLK to compute the actual time duration (in ns) of the parameter in question.
 - Per the 60x bus protocol, \overline{TS} , \overline{ABB} , and \overline{DBB} are driven only by the currently active bus master. They are asserted low, then precharged high before returning to high-Z as shown in Figure 5-5. The nominal precharge width for \overline{TS} , \overline{ABB} , or \overline{DBB} is $0.5 \times t_{sysclk}$, that is, less than the minimum t_{sysclk} period, to ensure that another master asserting \overline{TS} , \overline{ABB} , or \overline{DBB} on the following clock will not contend with the precharge. Output valid and output hold timing is tested for the signal asserted. Output valid time is tested for precharge. The high-Z behavior is guaranteed by design.

5. Per the 60x bus protocol, $\overline{\text{ARTRY}}$ can be driven by multiple bus masters through the clock period immediately following AACK. Bus contention is not an issue since any master asserting $\overline{\text{ARTRY}}$ will be driving it low. Any master asserting it low in the first clock following AACK will then go to high-Z for one clock before precharging it high during the second cycle after the assertion of AACK. The nominal precharge width for $\overline{\text{ARTRY}}$ is $1.0 t_{\text{sysclk}}$; that is, it should be high-Z as shown in [Figure 5-5](#) before the first opportunity for another master to assert $\overline{\text{ARTRY}}$. Output valid and output hold timing is tested for the signal asserted. Output valid time is tested for precharge. The high-Z and precharge behavior is guaranteed by design.
6. MCP and SRESET must be held asserted for a minimum of two bus clock cycles; INT and SMI should be held asserted until the exception is taken; CKSTP_IN must be held asserted until the system has been reset. See the *MPC750 RISC Microprocessor Family User's Manual* for more information. PC755 RISC Microprocessor Hardware Specifications, Rev. 8

[Figure 5-5](#) provides the input/output timing diagram for the PC755.

Figure 5-5. Input/Output Timing Diagram

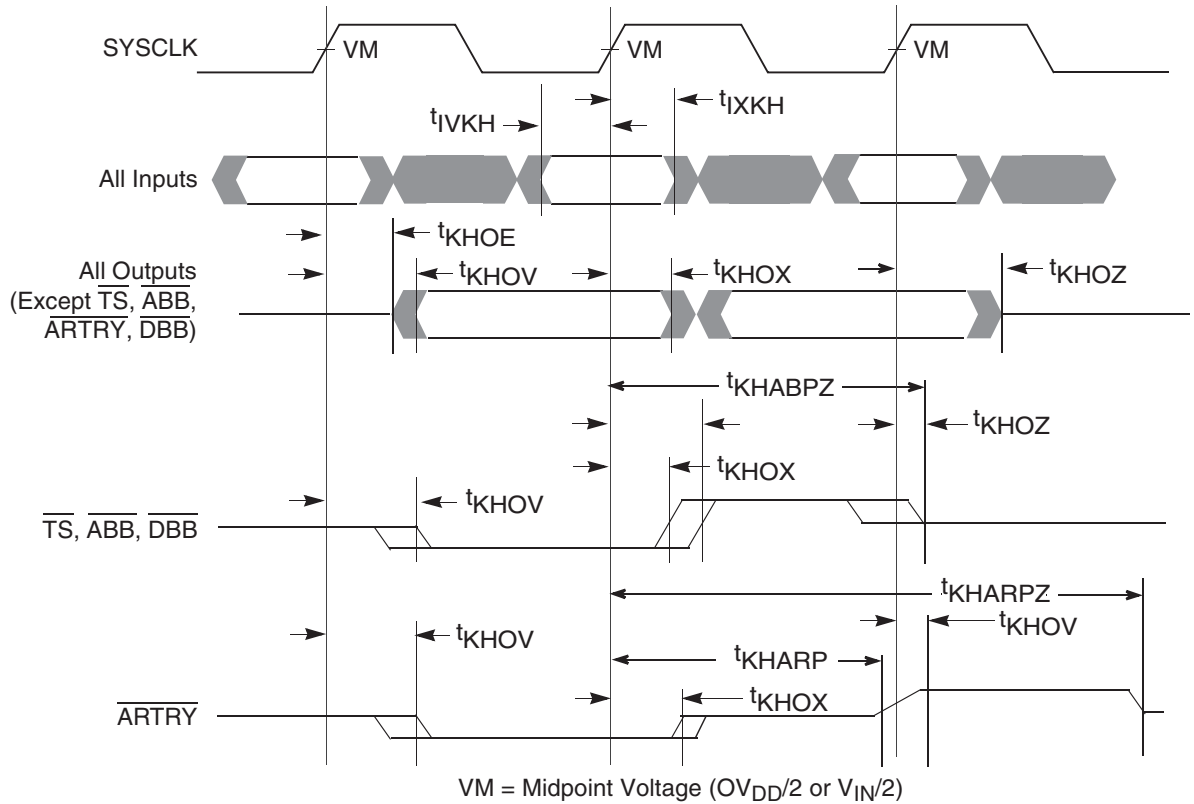

5.3.3 L2 Clock AC Specifications

The L2CLK frequency is programmed by the L2 configuration register (L2CR[4–6]) core-to-L2 divisor ratio. See [Table 9-2 on page 47](#) for example core and L2 frequencies at various divisors. [Table 5-13 on page 18](#) provides the potential range of L2CLK output AC timing specifications as defined in [Figure 5-6](#).

The minimum L2CLK frequency of [Table 5-13](#) is specified by the maximum delay of the internal DLL. The variable-tap DLL introduces up to a full clock period delay in the L2CLK_OUTA, L2CLK_OUTB, and L2SYNC_OUT signals so that the returning L2SYNC_IN signal is phase-aligned with the next core clock (divided by the L2 divisor ratio). Do not choose a core-to-L2 divisor which results in an L2 frequency below this minimum, or the L2CLK_OUT signals provided for SRAM clocking will not be phase-aligned with the PC755 core clock at the SRAMs.

The maximum L2CLK frequency shown in [Table 5-13](#) is the core frequency divided by one. Very few L2 SRAM designs will be able to operate in this mode, especially at higher core frequencies. Therefore, most designs will select a greater core-to-L2 divisor to provide a longer L2CLK period for read and write access to the L2 SRAMs. The maximum L2CLK frequency for any application of the PC755 will be a function of the AC timings of the PC755, the AC timings for the SRAM, bus loading, and printed-circuit board trace length. The current AC timing of the PC755 supports up to 200 MHz with typical, similarly-rated SRAM parts, provided careful design practices are observed. Clock trace lengths must be matched and all trace lengths should be as short as possible. Higher frequencies can be achieved by using better performing SRAM. Note that revisions of the PC755 prior to Rev. 2.8 (Rev. E) were limited in performance, and were typically limited to 175 MHz with similarly-rated SRAM.

For more information, see [Table 11-1, “Ordering Information,”](#) on page 60.

e2v is similarly limited by system constraints and cannot perform tests of the L2 interface on a socketed part on a functional tester at the maximum frequencies of [Table 5-13](#). Therefore, functional operation and AC timing information are tested at core-to-L2 divisors of 2 or greater. Functionality of core-to-L2 divisors of 1 or 1.5 is verified at less than maximum rated frequencies.

L2 input and output signals are latched or enabled, respectively, by the internal L2CLK (which is SYSCLK multiplied up to the core frequency and divided down to the L2CLK frequency). In other words, the AC timings of [Table 5-14](#) and [Table 5-15 on page 22](#) are entirely independent of L2SYNC_IN. In a closed loop system, where L2SYNC_IN is driven through the board trace by L2SYNC_OUT, L2SYNC_IN only controls the output phase of L2CLK_OUTA and L2CLK_OUTB which are used to latch or enable data at the SRAMs.

However, since in a closed loop system L2SYNC_IN is held in phase alignment with the internal L2CLK, the signals of [Table 5-14](#) and [Table 5-15](#) are referenced to this signal rather than the not-externally-visible internal L2CLK. During manufacturing test, these times are actually measured relative to SYSCLK.

The L2SYNC_OUT signal is intended to be routed halfway out to the SRAMs and then returned to the L2SYNC_IN input of the PC755 to synchronize L2CLK_OUT at the SRAM with the processor’s internal clock. L2CLK_OUT at the SRAM can be offset forward or backward in time by shortening or lengthening the routing of L2SYNC_OUT to L2SYNC_IN. See Freescale Application Note AN1794/D, *Backside L2 Timing Analysis for PCB Design Engineers*.

The L2CLK_OUTA and L2CLK_OUTB signals should not have more than two loads.

Table 5-13. L2CLK Output AC Timing Specification at Recommended Operating Conditions (see [Table 5-3 on page 9](#))

Parameter	Symbols	All Speed Grades		Unit	Notes
		Min	Max		
L2CLK frequency	f_{L2CLK}	80	450	MHz	(1)(4)
L2CLK cycle time	t_{L2CLK}	2.5	12.5	ns	
L2CLK duty cycle	t_{CHCL}/t_{L2CLK}	45	55	%	(2)(7)
Internal DLL-relock time	–	640	–	L2CLK	(3)(7)
DLL capture window	–	0	10	ns	(5)(7)
L2CLKOUT output-to-output skew	t_{L2CSKW}	–	50	ps	(6)(7)
L2CLKOUT output jitter	–	–	±150	ps	(6)(7)

- Notes:
1. L2CLK outputs are L2CLK_OUTA, L2CLK_OUTB, L2CLK_OUT and L2SYNC_OUT pins. The L2CLK frequency-to-core frequency settings must be chosen such that the resulting L2CLK frequency and core frequency do not exceed their respective maximum or minimum operating frequencies. The maximum L2CLK frequency will be system dependent. L2CLK_OUTA and L2CLK_OUTB must have equal loading.
 2. The nominal duty cycle of the L2CLK is 50% measured at midpoint voltage.
 3. The DLL-relock time is specified in terms of L2CLK periods. The number in the table must be multiplied by the period of L2CLK to compute the actual time duration in ns. Relock timing is guaranteed by design and characterization.
 4. The L2CR[L2SL] bit should be set for L2CLK frequencies less than 110 MHz. This adds more delay to each tap of the DLL.
 5. Allowable skew between L2SYNC_OUT and L2SYNC_IN.
 6. This output jitter number represents the maximum delay of one tap forward or one tap back from the current DLL tap as the phase comparator seeks to minimize the phase difference between L2SYNC_IN and the internal L2CLK. This number must be comprehended in the L2 timing analysis. The input jitter on SYSCLK affects L2CLK_OUT and the L2 address/data/control signals equally and, therefore, is already comprehended in the AC timing and does not have to be considered in the L2 timing analysis.
 7. Guaranteed by design.

The L2CLK_OUT timing diagram is shown in [Figure 5-6](#).

Figure 5-6. L2CLK_OUT Output Timing Diagram

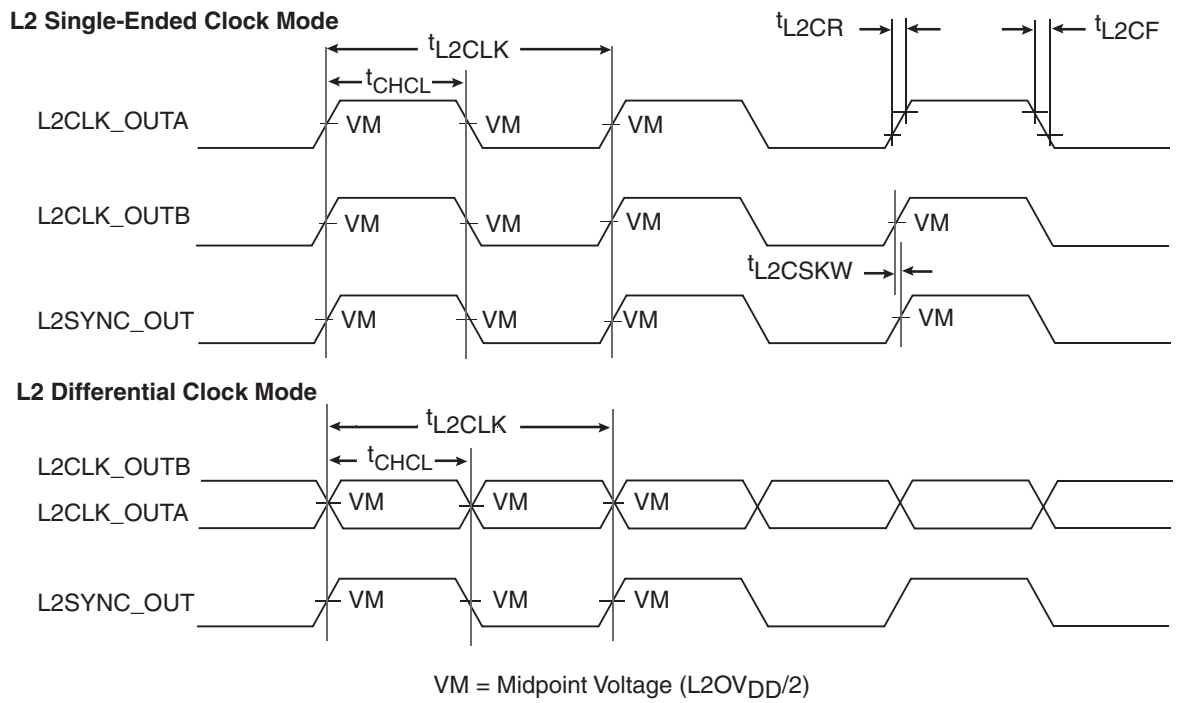

5.3.4 L2 Bus AC Specifications

Table 5-14 provides the L2 bus interface AC timing specifications for the PC755 as defined in Figure 5-7 on page 21 and Figure 5-8 on page 21 for the loading conditions described in Figure 5-9 on page 21.

Table 5-14. L2 Bus Interface AC Timing Specifications at Recommended Operating Conditions (see Table 5-3 on page 9)

Parameter	Symbol	All Speed Grades		Unit	Notes
		Min	Max		
L2SYNC_IN rise and fall time	t_{L2CR} & t_{L2CF}	–	1.0	ns	(1)
Setup times: data and parity	t_{DVL2CH}	1.2	–	ns	(2)
Input Hold Times: data and parity	t_{DXL2CH}	0	–	ns	(2)
Valid times: All outputs when L2CR[14–15] = 00 All outputs when L2CR[14–15] = 01 All outputs when L2CR[14–15] = 10 All outputs when L2CR[14–15] = 11	t_{L2CHOV}	–	3.1 3.2 3.3 3.7	ns	(3)(4)
Output Hold Times: All outputs when L2CR[14–15] = 00 All outputs when L2CR[14–15] = 01 All outputs when L2CR[14–15] = 10 All outputs when L2CR[14–15] = 11	t_{L2CHOX}	0.5 0.7 0.9 1.1	– – – –	ns	(3)
L2SYNC_IN to High Impedance: All outputs when L2CR[14–15] = 00 All outputs when L2CR[14–15] = 01 All outputs when L2CR[14–15] = 10 All outputs when L2CR[14–15] = 11	t_{L2CHOZ}	–	2.4 2.6 2.8 3.0	ns	(3)(5)

- Notes:
1. Rise and fall times for the L2SYNC_IN input are measured from 20% to 80% of $L2OV_{DD}$.
 2. All input specifications are measured from the midpoint of the signal in question to the midpoint voltage of the rising edge of the input L2SYNC_IN (see Figure 5-7 on page 21). Input timings are measured at the pins.
 3. All output specifications are measured from the midpoint voltage of the rising edge of L2SYNC_IN to the midpoint of the signal in question. The output timings are measured at the pins. All output timings assume a purely resistive 50Ω load (See Figure 5-9 on page 21).
 4. The outputs are valid for both single-ended and differential L2CLK modes. For pipelined registered synchronous BurstRAMs, L2CR[14–15] = 01 or 10 is recommended. For pipelined late write synchronous BurstRAMs, L2CR[14–15] = 11 is recommended.
 5. Guaranteed by design and characterization.
 6. Revisions prior to Rev 2.8 (Rev E) were limited in performance and did not conform to this specification. Contact your local e2v sales office for more information.

Figure 5-7 shows the L2 bus input timing diagrams for the PC755.

Figure 5-7. L2 Bus Input Timing Diagrams

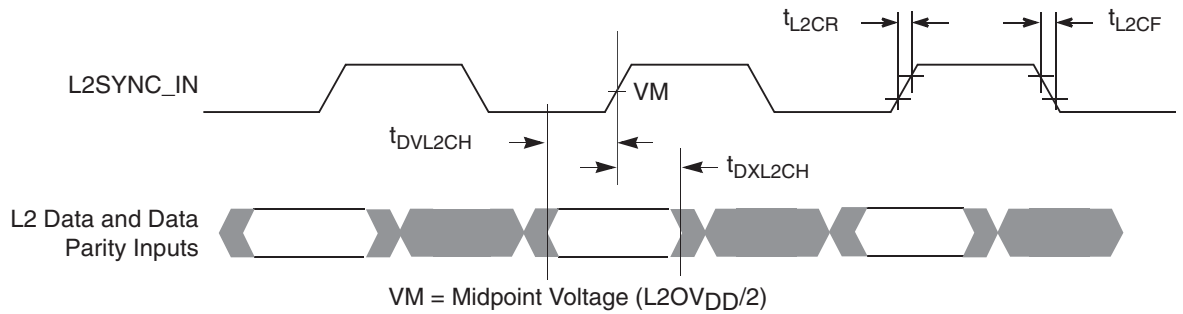

Figure 5-8 shows the L2 bus output timing diagrams for the PC755.

Figure 5-8. L2 Bus Output Timing Diagrams

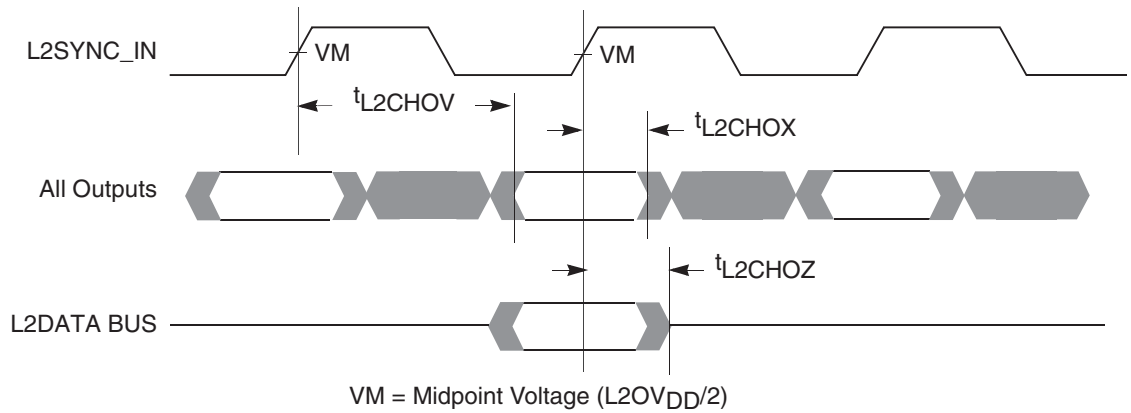
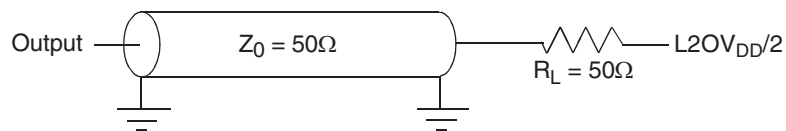

Figure 5-9 provides the AC test load for L2 interface of the PC755.

Figure 5-9. AC Test Load for the L2 Interface



5.3.5 IEEE 1149.1 AC Timing Specifications

Table 5-15 provides the IEEE 1149.1 (JTAG) AC timing specifications as defined in Figure 5-11 through Figure 5-14 on page 24.

Table 5-15. JTAG AC Timing Specifications (Independent of SYSCLK)⁽¹⁾

Parameter	Symbol	Min	Max	Unit	Notes
TCK frequency of operation	f_{TCLK}	0	16	MHz	
TCK cycle time	f_{TCLK}	62.5	–	ns	
TCK clock pulse width measured at 1.4V	t_{HJL}	31	–	ns	
TCK rise and fall times	t_{JR}, t_{JF}	0	2	ns	
\overline{TRST} assert time	t_{TRST}	25	–	ns	(2)
Input setup times: - Boundary-scan data - TMS, TDI	t_{DVJH} t_{VJH}	4 0	– –	ns	(3)
Input hold times: - Boundary-scan data - TMS, TDI	t_{DXJH} t_{IXJH}	15 12	– –	ns	(3)
Valid times: - Boundary-scan data - TDO	t_{JLDV} t_{JLOV}	– –	4 4	ns	(4)
Output hold times: - Boundary-scan data - TDO	t_{JLDV} t_{JLOV}	25 12	– –	ns	(4)
TCK to output high impedance: - Boundary-scan data - TDO	t_{JLDZ} t_{JLOZ}	3 3	19 9	ns	(4)(5)

- Notes:
1. All outputs are measured from the midpoint voltage of the falling/rising edge of TCLK to the midpoint of the signal in question. The output timings are measured at the pins. All output timings assume a purely resistive 50Ω load (See Figure 5-10). Time-of-flight delays must be added for trace lengths, vias, and connectors in the system.
 2. \overline{TRST} is an asynchronous level sensitive signal which must be asserted for this minimum time to be recognized
 3. Non-JTAG signal input timing with respect to TCK.
 4. Non-JTAG signal output timing with respect to TCK.
 5. Guaranteed by design and characterization.

Figure 5-10 provides the AC test load for TDO and the boundary-scan outputs of the PC755.

Figure 5-10. AC Test Load for the JTAG Interface

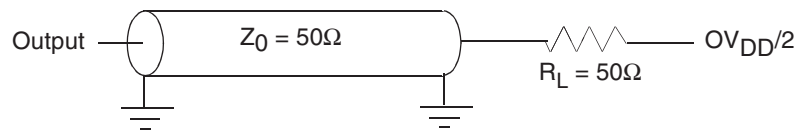

Figure 5-11 provides the JTAG clock input timing diagram.

Figure 5-11. JTAG Clock Input Timing Diagram

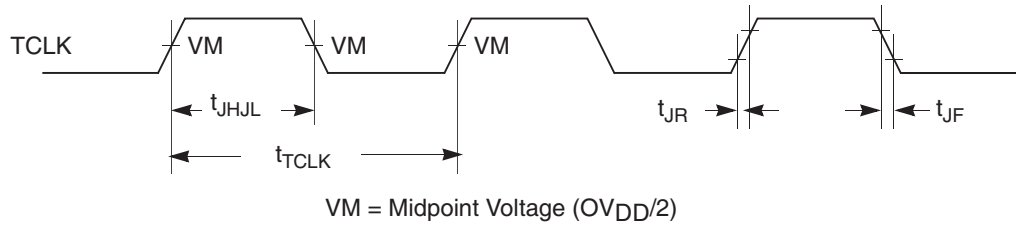

Figure 5-12 provides the TRST timing diagram.

Figure 5-12. TRST Timing Diagram

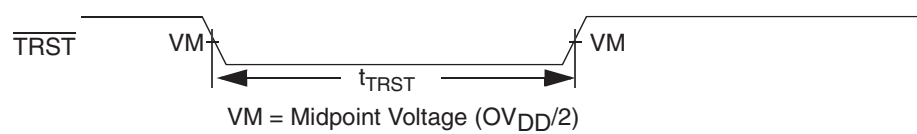

Figure 5-13 provides the boundary-scan timing diagram.

Figure 5-13. Boundary-Scan Timing Diagram

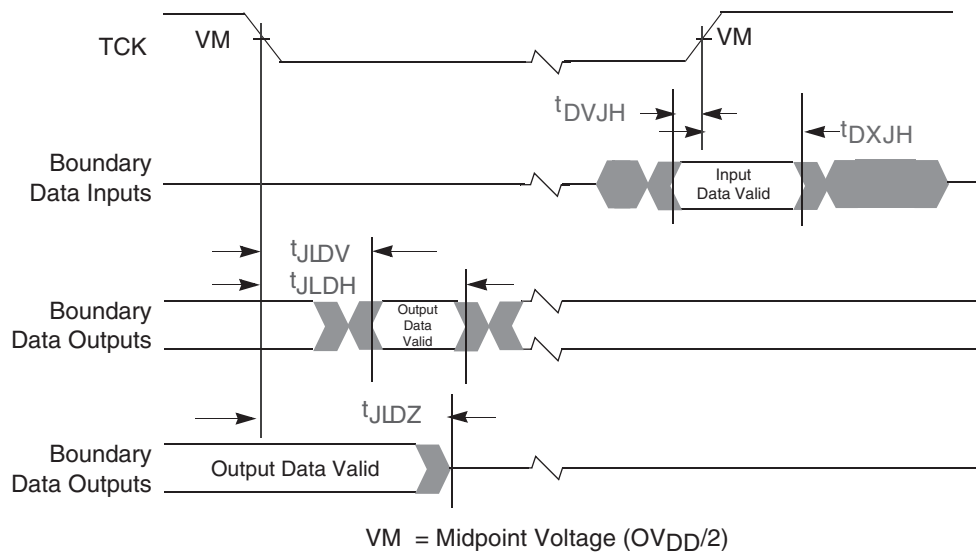
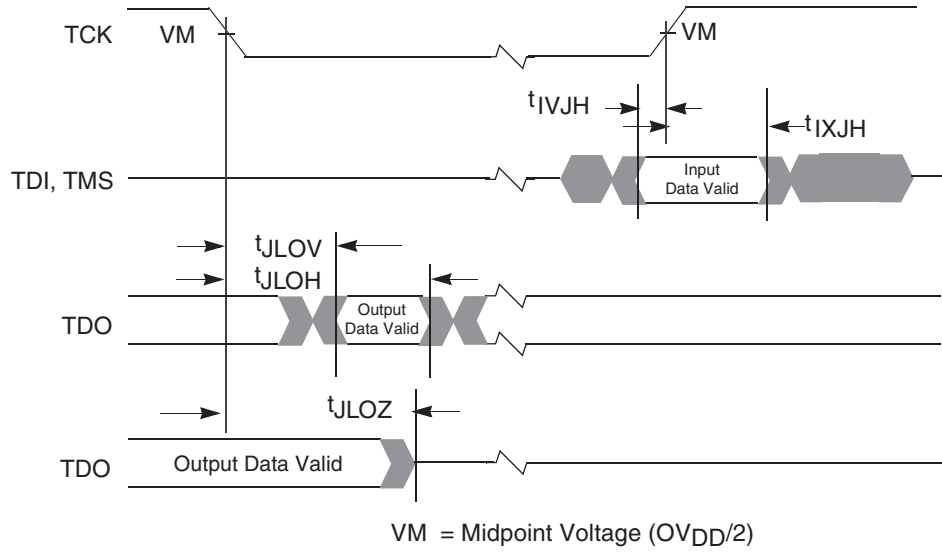

Figure 5-14 provides the test access port timing diagram.

Figure 5-14. Test Access Port Timing Diagram



6. PIN ASSIGNMENTS

Figure 6-1 on page 25 (in Part A) shows the pinout of the PC745, 255 PBGA and HiTCE CBGA packages as viewed from the top surface.

Part B shows the side profile of the PBGA and HiTCE packages to indicate the direction of the top surface view.

Figure 6-1. Pinout of the PC745, 255 PBGA and HiTCE CBGA Packages as Viewed from the Top Surface

Part A

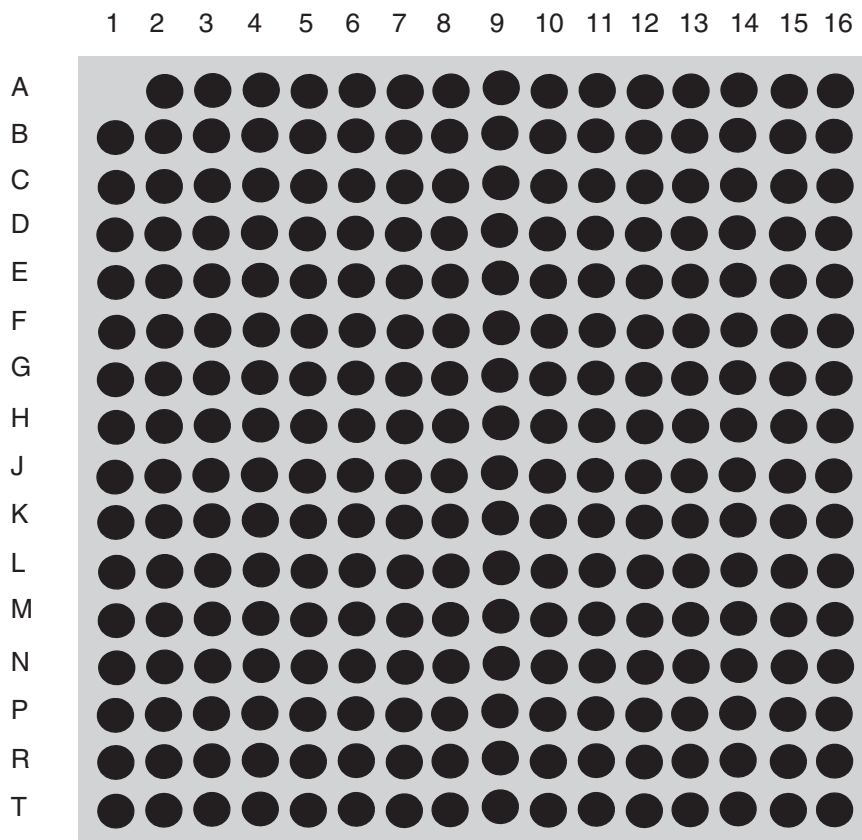

Not to Scale

Part B

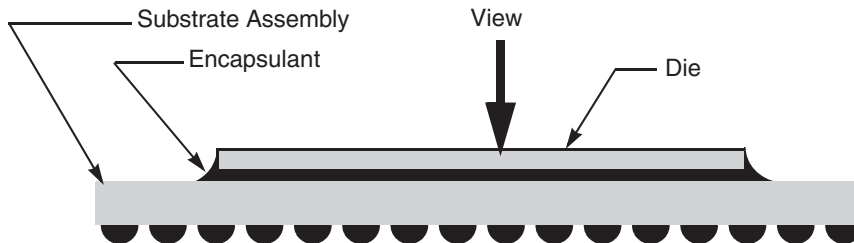
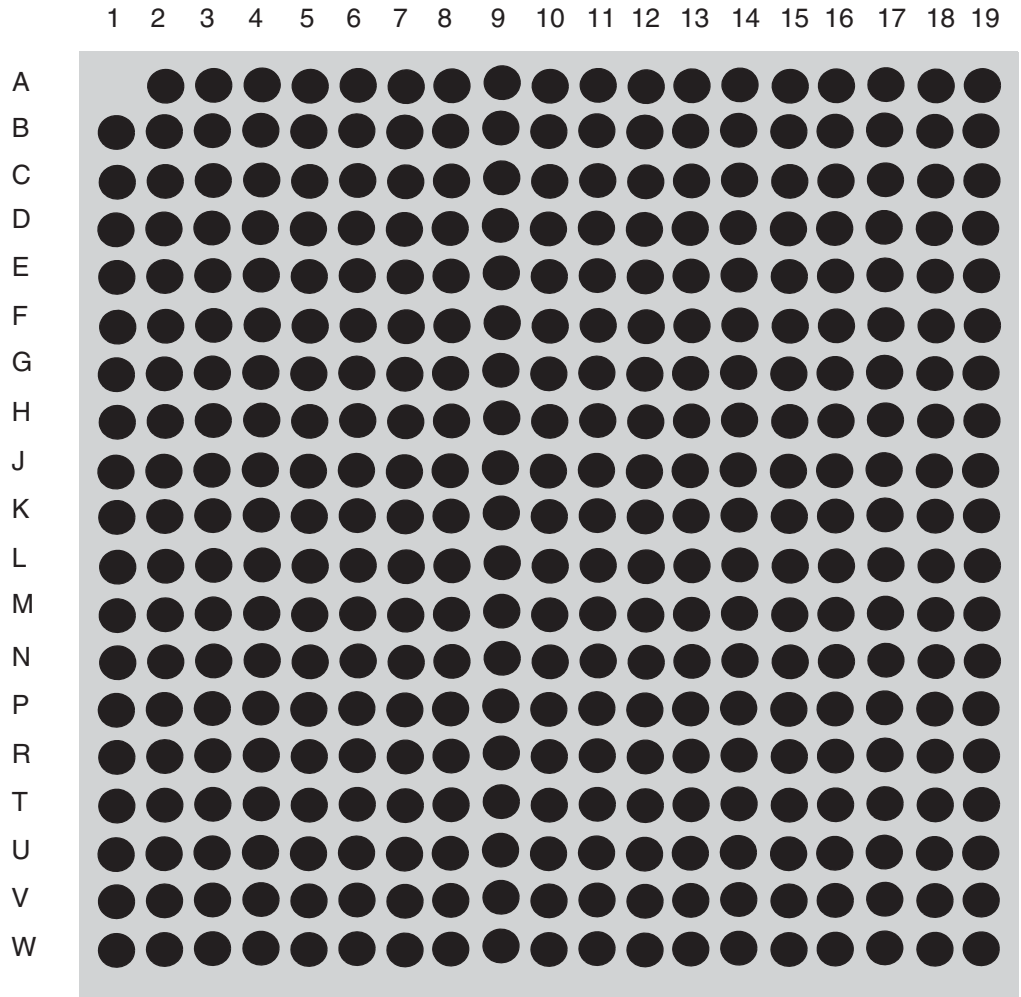

Figure 6-2 (in Part A) shows the pinout of the PC755, 360 PBGA, CBGA and HiTCE packages as viewed from the top surface. Part B shows the side profile of the PBGA, CBGA and HiTCE packages to indicate the direction of the top surface view.

Figure 6-2. Pinout of the PC755, 360 PBGA, CBGA and HiTCE packages as Viewed from the Top Surface

Part A



Not to Scale

Part B

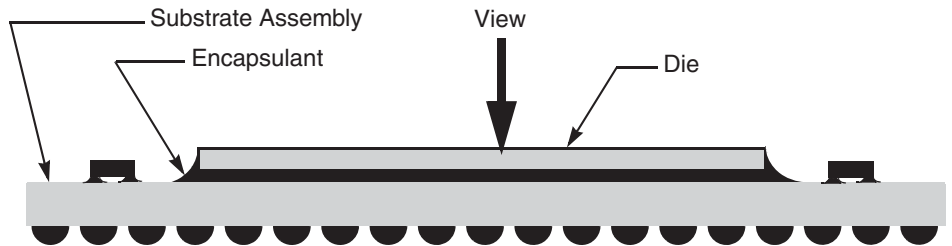

7. PINOUT LISTINGS

Table 7-1 provides the pinout listing for the PC745, 255 PBGA and HiTCE packages.

Table 7-1. Pinout Listing for the PC745, 255 BGA Package

Signal Name	Pin Number	Active	I/O	I/F Voltage ⁽¹⁾	Notes
A[0:31]	C16, E4, D13, F2, D14, G1, D15, E2, D16, D4, E13, G2, E15, H1, E16, H2, F13, J1, F14, J2, F15, H3, F16, F4, G13, K1, G15, K2, H16, M1, J15, P1	High	I/O	OV _{DD}	
$\overline{\text{AACK}}$	L2	Low	Input	OV _{DD}	
$\overline{\text{ABB}}$	K4	Low	I/O	OV _{DD}	
AP[0:3]	C1, B4, B3, B2	High	I/O	OV _{DD}	
$\overline{\text{ARTRY}}$	J4	Low	I/O	OV _{DD}	
AV _{DD}	A10	–	–	2.0 V	
$\overline{\text{BG}}$	L1	Low	Input	OV _{DD}	
$\overline{\text{BR}}$	B6	Low	Output	OV _{DD}	
BVSEL	B1	High	Input	OV _{DD}	(3)(4)(5)
$\overline{\text{CI}}$	E1	Low	Output	OV _{DD}	
$\overline{\text{CKSTP_IN}}$	D8	Low	Input	OV _{DD}	
$\overline{\text{CKSTP_OUT}}$	A6	Low	Output	OV _{DD}	
CLK_OUT	D7	–	Output	OV _{DD}	
$\overline{\text{DBB}}$	J14	Low	I/O	OV _{DD}	
$\overline{\text{DBG}}$	N1	Low	Input	OV _{DD}	
$\overline{\text{DBDIS}}$	H15	Low	Input	OV _{DD}	
$\overline{\text{DBW0}}$	G4	Low	Input	OV _{DD}	
DH[0:31]	P14, T16, R15, T15, R13, R12, P11, N11, R11, T12, T11, R10, P9, N9, T10, R9, T9, P8, N8, R8, T8, N7, R7, T7, P6, N6, R6, T6, R5, N5, T5, T4	High	I/O	OV _{DD}	
DL[0:31]	K13, K15, K16, L16, L15, L13, L14, M16, M15, M13, N16, N15, N13, N14, P16, P15, R16, R14, T14, N10, P13, N12, T13, P3, N3, N4, R3, T1, T2, P4, T3, R4	High	I/O	OV _{DD}	
DP[0:7]	M2, L3, N2, L4, R1, P2, M4, R2	High	I/O	OV _{DD}	
$\overline{\text{DRTRY}}$	G16	Low	Input	OV _{DD}	
$\overline{\text{GBL}}$	F1	Low	I/O	OV _{DD}	
GND	C5, C12, E3, E6, E8, E9, E11, E14, F5, F7, F10, F12, G6, G8, G9, G11, H5, H7, H10, H12, J5, J7, J10, J12, K6, K8, K9, K11, L5, L7, L10, L12, M3, M6, M8, M9, M11, M14, P5, P12	–	–	GND	
$\overline{\text{HRESET}}$	A7	Low	Input	OV _{DD}	
$\overline{\text{INT}}$	B15	Low	Input	OV _{DD}	
L1_TSTCLK	D11	High	Input	–	(2)
L2_TSTCLK	D12	High	Input	–	(2)
$\overline{\text{LSSD_MODE}}$	B10	Low	Input	–	(2)
$\overline{\text{MCP}}$	C13	Low	Input	OV _{DD}	
NC (No Connect)	B7, B8, C3, C6, C8, D5, D6, H4, J16, A4, A5, A2, A3, B5	–	–	–	

Table 7-1. Pinout Listing for the PC745, 255 BGA Package (Continued)

Signal Name	Pin Number	Active	I/O	I/F Voltage ⁽¹⁾	Notes
OV _{DD}	C7, E5, E7, E10, E12, G3, G5, G12, G14, K3, K5, K12, K14, M5, M7, M10, M12, P7, P10	–	–	2.5 V/3.3 V	
PLL_CFG[0:3]	A8, B9, A9, D9	High	Input	OV _{DD}	
$\overline{\text{QACK}}$	D3	Low	Input	OV _{DD}	
$\overline{\text{QREQ}}$	J3	Low	Output	OV _{DD}	
$\overline{\text{RSRV}}$	D1	Low	Output	OV _{DD}	
$\overline{\text{SMI}}$	A16	Low	Input	OV _{DD}	
$\overline{\text{SRESET}}$	B14	Low	Input	OV _{DD}	
SYSCLK	C9	–	Input	OV _{DD}	
$\overline{\text{TA}}$	H14	Low	Input	OV _{DD}	
TBEN	C2	High	Input	OV _{DD}	
$\overline{\text{TBST}}$	A14	Low	I/O	OV _{DD}	
TCK	C11	High	Input	OV _{DD}	
TDI	A11	High	Input	OV _{DD}	(5)
TDO	A12	High	Output	OV _{DD}	
$\overline{\text{TEA}}$	H13	Low	Input	OV _{DD}	
$\overline{\text{TLBISYNC}}$	C4	Low	Input	OV _{DD}	
TMS	B11	High	Input	OV _{DD}	(5)
$\overline{\text{TRST}}$	C10	Low	Input	OV _{DD}	(5)
$\overline{\text{TS}}$	J13	Low	I/O	OV _{DD}	
TSIZ[0:2]	A13, D10, B12	High	Output	OV _{DD}	
TT[0:4]	B13, A15, B16, C14, C15	High	I/O	OV _{DD}	
$\overline{\text{WT}}$	D2	Low	Output	OV _{DD}	
V _{DD}	F6, F8, F9, F11, G7, G10, H6, H8, H9, H11, J6, J8, J9, J11, K7, K10, L6, L8, L9, L11	–	–	2.0 V	
VOLTDET	F3	High	Output	–	(6)

- Notes:
1. OV_{DD} supplies power to the processor bus, JTAG, and all control signals; and V_{DD} supplies power to the processor core and the PLL (after filtering to become AV_{DD}). These columns serve as a reference for the nominal voltage supported on a given signal as selected by the BVSEL pin configuration of [Table 5-2 on page 8](#) and the voltage supplied. For actual recommended value of V_{in} or supply voltages, see [Table 5-3 on page 9](#).
 2. These are test signals for factory use only and must be pulled up to OV_{DD} for normal machine operation.
 3. This pin must be pulled up to OV_{DD} for proper operation of the processor interface. To allow for future I/O voltage changes, provide the option to connect BVSEL independently to either OV_{DD} or GND.
 4. Uses 1 of 15 existing no connects in the PC740, 255 BGA package.
 5. Internal pull-up on die.
 6. Internally tied to GND in the PC745, 255 BGA package to indicate to the power supply that a low-voltage processor is present. This signal is not a power supply input.
Caution: This differs from the PC755, 360 BGA package.

Table 7-2 provides the pinout listing for the PC755, 360 PBGA, CBGA and HiTCE packages.

Table 7-2. Pinout Listing for the PC755, 360 BGA Package

Signal Name	Pin Number	Active	I/O	I/F Voltage ⁽¹⁾	Notes
A[0:31]	A13, D2, H11, C1, B13, F2, C13, E5, D13, G7, F12, G3, G6, H2, E2, L3, G5, L4, G4, J4, H7, E1, G2, F3, J7, M3, H3, J2, J6, K3, K2, L2	High	I/O	OV_{DD}	
\overline{AACK}	N3	Low	Input	OV_{DD}	
\overline{ABB}	L7	Low	I/O	OV_{DD}	
AP[0:3]	C4, C5, C6, C7	High	I/O	OV_{DD}	
\overline{ARTRY}	L6	Low	I/O	OV_{DD}	
AV_{DD}	A8	–	–	2.0 V	
\overline{BG}	H1	Low	Input	OV_{DD}	
\overline{BR}	E7	Low	Output	OV_{DD}	
BVSEL	W1	High	Input	OV_{DD}	(3)(5)(6)
\overline{CI}	C2	Low	Output	OV_{DD}	
$\overline{CKSTP_IN}$	B8	Low	Input	OV_{DD}	
$\overline{CKSTP_OUT}$	D7	Low	Output	OV_{DD}	
CLK_OUT	E3	–	Output	OV_{DD}	
\overline{DBB}	K5	Low	I/O	OV_{DD}	
\overline{DBDIS}	G1	Low	Input	OV_{DD}	
\overline{DBG}	K1	Low	Input	OV_{DD}	
\overline{DBWO}	D1	Low	Input	OV_{DD}	
DH[0:31]	W12, W11, V11, T9, W10, U9, U10, M11, M9, P8, W7, P9, W9, R10, W6, V7, V6, U8, V9, T7, U7, R7, U6, W5, U5, W4, P7, V5, V4, W3, U4, R5	High	I/O	OV_{DD}	
DL[0:31]	M6, P3, N4, N5, R3, M7, T2, N6, U2, N7, P11, V13, U12, P12, T13, W13, U13, V10, W8, T11, U11, V12, V8, T1, P1, V1, U1, N1, R2, V3, U3, W2	High	I/O	OV_{DD}	
DP[0:7]	L1, P2, M2, V2, M1, N2, T3, R1	High	I/O	OV_{DD}	
\overline{DRTRY}	H6	Low	Input	OV_{DD}	
\overline{GBL}	B1	Low	I/O	OV_{DD}	
GND	D10, D14, D16, D4, D6, E12, E8, F4, F6, F10, F14, F16, G9, G11, H5, H8, H10, H12, H15, J9, J11, K4, K6, K8, K10, K12, K14, K16, L9, L11, M5, M8, M10, M12, M15, N9, N11, P4, P6, P10, P14, P16, R8, R12, T4, T6, T10, T14, T16	–	–	GND	
\overline{HRESET}	B6	Low	Input	OV_{DD}	
\overline{INT}	C11	Low	Input	OV_{DD}	
L1_TSTCLK	F8	High	Input	–	(2)
L2ADDR[16:0]	G18, H19, J13, J14, H17, H18, J16, J17, J18, J19, K15, K17, K18, M19, L19, L18, L17	High	Output	$L2OV_{DD}$	
$L2AV_{DD}$	L13	–	–	2.0 V	
$\overline{L2CE}$	P17	Low	Output	$L2OV_{DD}$	
L2CLK_OUTA	N15	–	Output	$L2OV_{DD}$	
L2CLK_OUTB	L16	–	Output	$L2OV_{DD}$	

Table 7-2. Pinout Listing for the PC755, 360 BGA Package (Continued)

Signal Name	Pin Number	Active	I/O	I/F Voltage ⁽¹⁾	Notes
L2DATA[0:63]	U14, R13, W14, W15, V15, U15, W16, V16, W17, V17, U17, W18, V18, U18, V19, U19, T18, T17, R19, R18, R17, R15, P19, P18, P13, N14, N13, N19, N17, M17, M13, M18, H13, G19, G16, G15, G14, G13, F19, F18, F13, E19, E18, E17, E15, D19, D18, D17, C18, C17, B19, B18, B17, A18, A17, A16, B16, C16, A14, A15, C15, B14, C14, E13	High	I/O	L2OV _{DD}	
L2DP[0:7]	V14, U16, T19, N18, H14, F17, C19, B15	High	I/O	L2OV _{DD}	
L2OV _{DD}	D15, E14, E16, H16, J15, L15, M16, P15, R14, R16, T15, F15	–	–	L2OV _{DD}	
L2SYNC_IN	L14	–	Input	L2OV _{DD}	
L2SYNC_OUT	M14	–	Output	L2OV _{DD}	
L2_TSTCLK	F7	High	Input	–	(2)
L2VSEL	A19	High	Input	L2OV _{DD}	(1)(5)(6)(7)
L2WE	N16	Low	Output	L2OV _{DD}	
L2ZZ	G17	High	Output	L2OV _{DD}	
LSSD_MODE	F9	Low	Input	–	(2)
MCP	B11	Low	Input	OV _{DD}	
NC (No Connect)	B3, B4, B5, W19, K9, K11 ⁴ , K19 ⁴	–	–	–	
OV _{DD}	D5, D8, D12, E4, E6, E9, E11, F5, H4, J5, L5, M4, P5, R4, R6, R9, R11, T5, T8, T12	–	–	OV _{DD}	
PLL_CFG[0:3]	A4, A5, A6, A7	High	Input	OV _{DD}	
QACK	B2	Low	Input	OV _{DD}	
QREQ	J3	Low	Output	OV _{DD}	
RSRV	D3	Low	Output	OV _{DD}	
SMI	A12	Low	Input	OV _{DD}	
SRESET	E10	Low	Input	OV _{DD}	
SYSCLK	H9	–	Input	OV _{DD}	
TA	F1	Low	Input	OV _{DD}	
TBEN	A2	High	Input	OV _{DD}	
TBST	A11	Low	I/O	OV _{DD}	
TCK	B10	High	Input	OV _{DD}	
TDI	B7	High	Input	OV _{DD}	(6)
TDO	D9	High	Output	OV _{DD}	
TEA	J1	Low	Input	OV _{DD}	
TLBISYNC	A3	Low	Input	OV _{DD}	
TMS	C8	High	Input	OV _{DD}	(6)
TRST	A10	Low	Input	OV _{DD}	(6)
TS	K7	Low	I/O	OV _{DD}	
TSIZ[0:2]	A9, B9, C9	High	Output	OV _{DD}	
TT[0:4]	C10, D11, B12, C12, F11	High	I/O	OV _{DD}	

Table 7-2. Pinout Listing for the PC755, 360 BGA Package (Continued)

Signal Name	Pin Number	Active	I/O	I/F Voltage ⁽¹⁾	Notes
\overline{WT}	C3	Low	Output	OV_{DD}	
V_{DD}	G8, G10, G12, J8, J10, J12, L8, L10, L12, N8, N10, N12	–	–	2.0 V	
VOLTDET	K13	High	Output	$L2OV_{DD}$	(8)

- Notes:
1. OV_{DD} supplies power to the processor bus, JTAG, and all control signals except the L2 cache controls (L2CE, L2WE, and L2ZZ); $L2OV_{DD}$ supplies power to the L2 cache interface (L2ADDR[0:16], L2DATA[0:63], L2DP[0:7], and L2SYNC_OUT) and the L2 control signals; and V_{DD} supplies power to the processor core and the PLL and DLL (after filtering to become AVDD and L2AVDD, respectively). These columns serve as a reference for the nominal voltage supported on a given signal as selected by the BVSEL/L2VSEL pin configurations of [Table 5-2 on page 8](#) and the voltage supplied. For actual recommended value of V_{in} or supply voltages, see [Table 5-3 on page 9](#).
 2. These are test signals for factory use only and must be pulled up to OV_{DD} for normal machine operation.
 3. This pin must be pulled up to OV_{DD} for proper operation of the processor interface. To allow for future I/O voltage changes, provide the option to connect BVSEL independently to either OV_{DD} or GND.
 4. These pins are reserved for potential future use as additional L2 address pins.
 5. Uses one of nine existing no connects in the PC750, 360 BGA package.
 6. Internal pull-up on die.
 7. This pin must be pulled up to $L2OV_{DD}$ for proper operation of the processor interface. To allow for future I/O voltage changes, provide the option to connect L2VSEL independently to either $L2OV_{DD}$ or GND.
 8. Internally tied to $L2OV_{DD}$ in the PC755, 360 BGA package to indicate the power present at the L2 cache interface. This signal is not a power supply input.
Caution: This differs from the PC745, 255 BGA package.

Figure 7-1. PC755 Microprocessor Signal Groups

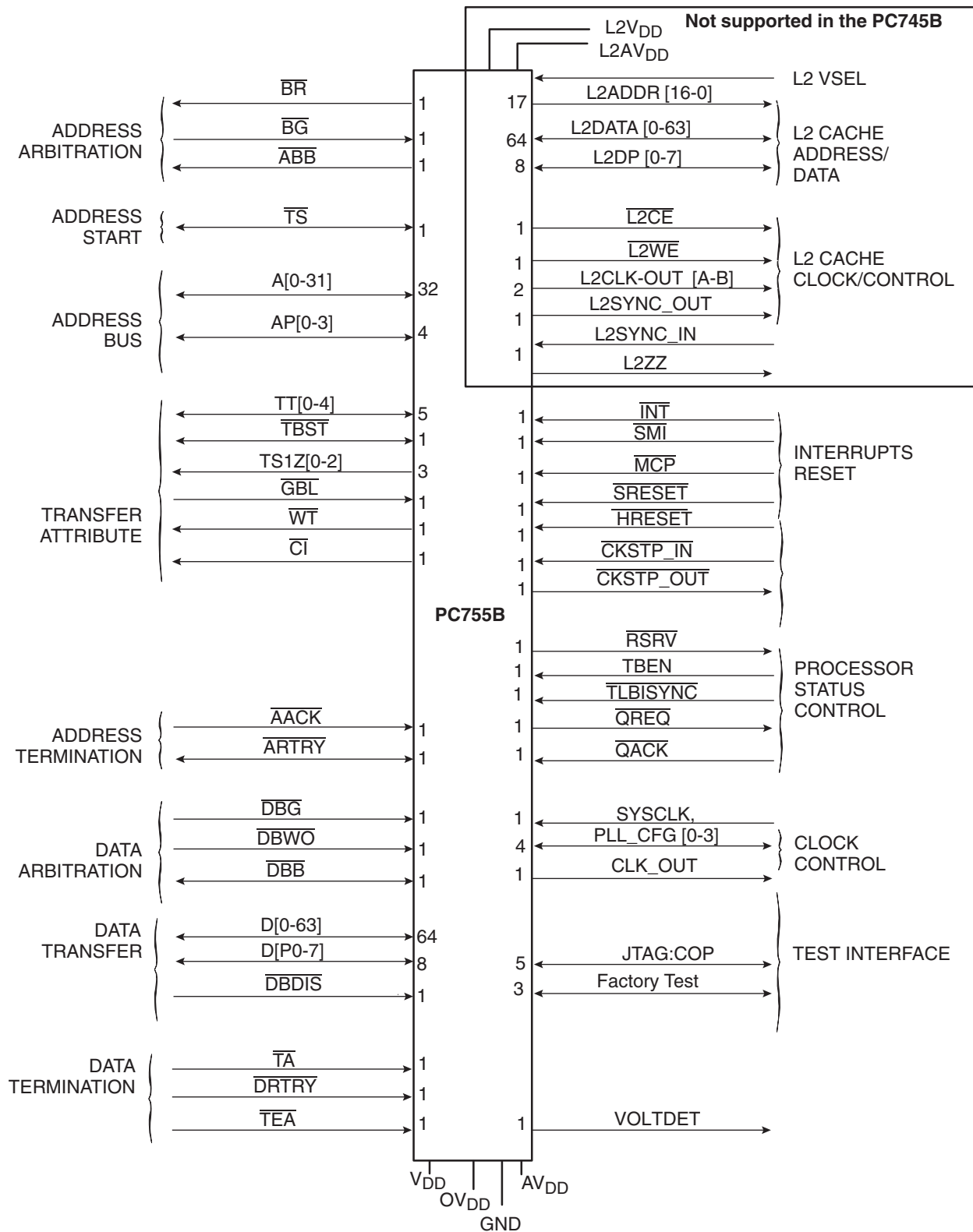

8. PACKAGE MECHANICAL DATA

The following sections provide the package parameters and mechanical dimensions for the PC745, 255 PBGA HiTCE package as well as the PC755, 360 CBGA, PBGA and HiTCE packages. While the PC755 plastic, the ceramic and the HiTCE packages are described here, these packages are not guaranteed to be available at the same time. All new designs should allow for either ceramic, HiTCE, or plastic BGA packages for this device. For more information on designing a common footprint for both plastic and ceramic package types, please contact your local e2v sales office.

8.1 Package Parameters for the PC745

The package parameters are as provided in the following list. The package type is 21 × 21 mm, 255-lead ball grid array (BGA).

Table 8-1. Package Parameters

Parameter	HiTCE	PBGA
Package outline	21 × 21 mm	21 × 21 mm
Interconnects	255 (16 × 16 ball array – 1)	255 (16 × 16 ball array – 1)
Pitch	1.27 mm (50 mil)	1.27 mm (50 mil)

Table 8-2. Package Type Parameters

Package code	GH	SH	ZF	ZT
Solder spheres composition	Sn (10%) Pb (90%)	Sn (96.5%) Ag (3%) Cu (0.5%)	Sn (62%) Pb (36%) Ag (2%)	Sn (96.5%) Ag (3.5%)
RoHS	No	Yes	No	Yes
Minimum module height	2.42 mm	2.02 mm	2.25 mm	2.25 mm
Maximum module height	3.08 mm	2.68 mm	2.80 mm	2.80 mm
Ball diameter (typical)	0.89 mm (35 mil)	0.75 mm (29.5 mil)	0.75 mm (29.5 mil)	0.75 mm (29.5 mil)

8.1.1 Mechanical Dimensions of the PC745 HiTCE Package

Figure 8-1 provides the mechanical dimensions and bottom surface nomenclature of the PC745, 255 HiTCE package.

Figure 8-1. Mechanical Dimensions and Bottom Surface Nomenclature of the PC745 HiTCE (GH)

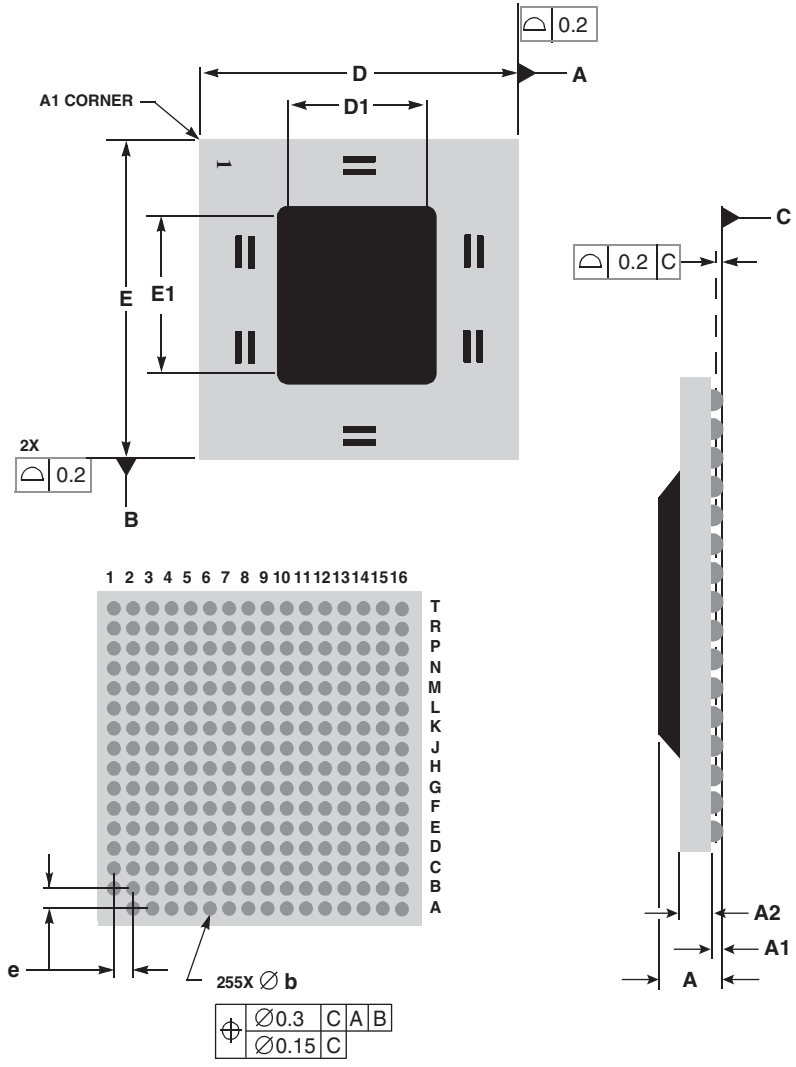

Notes:

1. Dimensioning and tolerancing per ASME Y14.5M, 1994
2. Dimensions in millimeters
3. Top side A1 corner index is a metalized feature with various shapes. Bottom side A1 corner is designated with a ball missing from the array
4. Capacitor Pads may be unpopulated

Figure 8-2. Mechanical Dimensions and Bottom Surface Nomenclature of the PC745 HiTCE RoHS (SH)

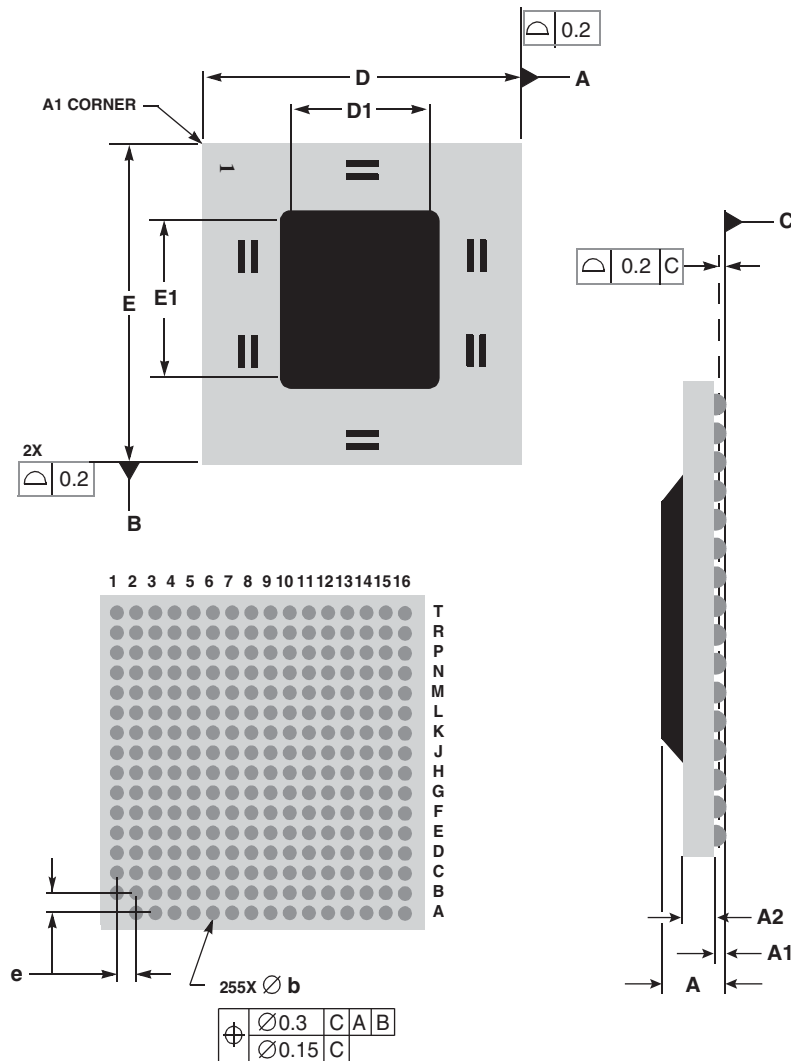

Notes:

1. Dimensioning and tolerancing per ASME Y14.5M, 1994
2. Dimensions in millimeters
3. Top side A1 corner index is a metalized feature with various shapes. Bottom side A1 corner is designated with a ball missing from the array
4. Capacitor Pads may be unpopulated

Solder spheres finishing:

1. Sn (10%) / Pb (90%)
2. Sn (96,5%) Ag (3%) Cu (0,5%)

8.1.2 Mechanical Dimensions of the PC745 PBGA Package

Figure 8-3 provides the mechanical dimensions and bottom surface nomenclature of the PC745, 255 PBGA package.

Figure 8-3. Mechanical Dimensions and Bottom Surface Nomenclature of the PC745 PBGA (ZF)

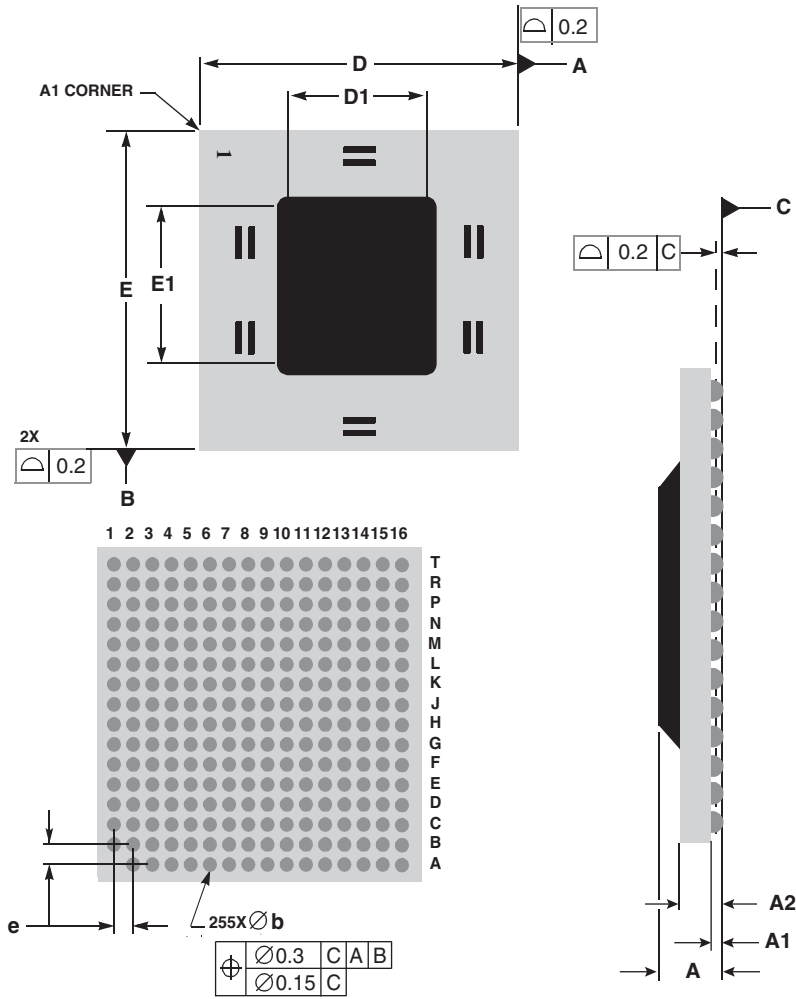

Notes:

1. Dimensioning and tolerancing per ASME Y14.5M, 1994
2. Dimensions in millimeters
3. Top side A1 corner index is a metalized feature with various shapes. Bottom side A1 corner is designated with a ball missing from the array
4. Capacitor Pads may be unpopulated

	Millimeters ⁽¹⁾	
Dim	Min	Max
A	2.25	2.80
A1	0.50	0.70
A2	1.00	1.20
b	0.60	0.90
D	21.00 BSC	
D1	6.75	
E	21.00 BSC	
E1	7.87	
e	1.27 BSC	

Figure 8-4. Mechanical Dimensions and Bottom Surface Nomenclature of the PC745 (PBGA-RoHS) (ZT)

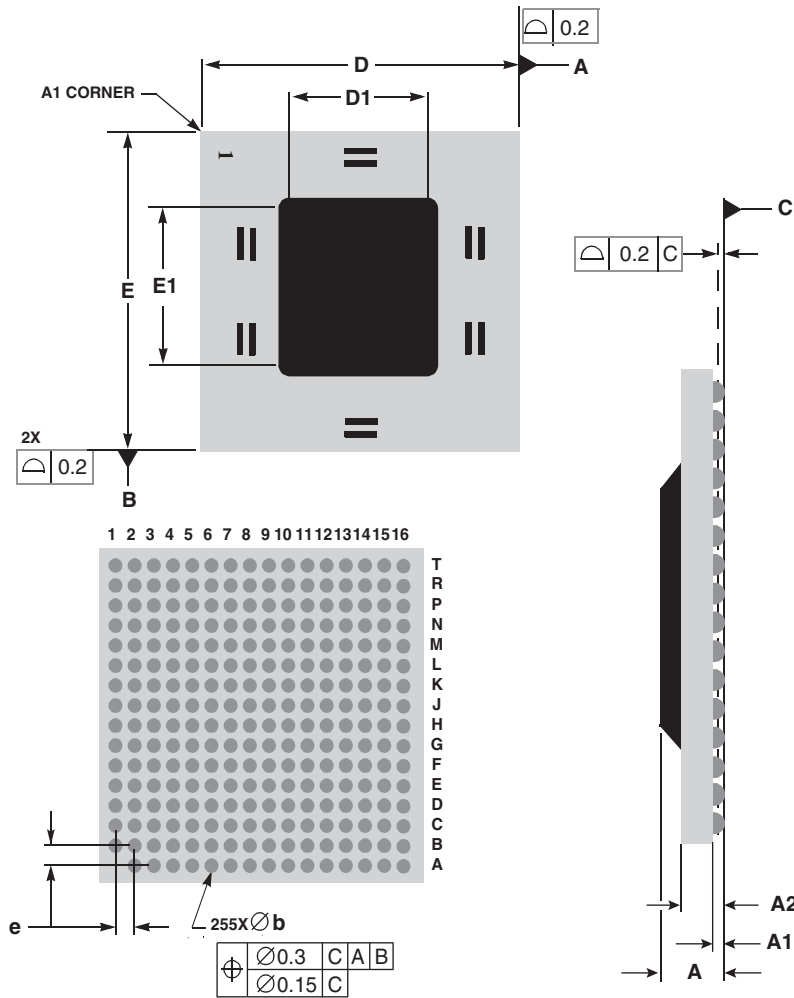

Notes:

1. Dimensioning and tolerancing per ASME Y14.5M, 1994
2. Dimensions in millimeters
3. Top side A1 corner index is a metalized feature with various shapes. Bottom side A1 corner is designated with a ball missing from the array
4. Capacitor Pads may be unpopulated

Dim	Millimeters ⁽¹⁾	
	Min	Max
A	2.25	2.80
A1	0.50	0.70
A2	1.00	1.20
b	0.60	0.90
D	21.00 BSC	
D1	6.75	
E	21.00 BSC	
E1	7.87	
e	1.27 BSC	

8.2 Package Parameter for the PC755

The package parameters are as provided in the following list. The package type is 25 × 25 mm, 360-lead ball grid array (BGA).

Table 8-3. Package Parameters

Parameter	HiTCE-CBGA	PBGA
Package Outline	25 mm × 25 mm	25 mm × 25 mm
Interconnects	360 (19 × 19 ball array – 1)	360 (19 × 19 ball array – 1)
Pitch	1.27 mm (50 mil)	1.27 mm (50 mil)

Table 8-4. Package Type Parameters

Package code	GH/G	SH	PH	ZF	ZT	GS
Solder spheres composition	Sn (10%) Pb (90%)	Sn (96.5%) Ag (3%) Cu (0.5%)	Sn (96.3%) Ag (3.7%)	Sn (62%) Pb (36%) Ag (2%)	Sn (96.5%) Ag (3.5%)	Sn (10%) Pb (90%)
RoHS compliant	No	Yes	Yes	No	Yes	No
Minimum module height	2.65 mm	2.32 mm	2.65 mm	2.22 mm	2.22 mm	3.65 mm
Maximum module height	3.2 mm	2.8 mm	3.2 mm	2.77 mm	2.77 mm	4.2 mm
Ball diameter (typical)	0.89 mm (35 mil)	0.75 mm (29.5 mil)	0.89 mm (35 mil)	0.75 mm (29.5 mil)	0.75 mm (29.5 mil)	0.89 mm (35 mil)

8.2.1 Mechanical Dimensions of the PC755 PBGA Package

Figure 8-5 provides the mechanical dimensions and bottom surface nomenclature of the PC755, 360 PBGA package.

Figure 8-5. Mechanical Dimensions and Bottom Surface Nomenclature of the PC755 PBGA (ZF)

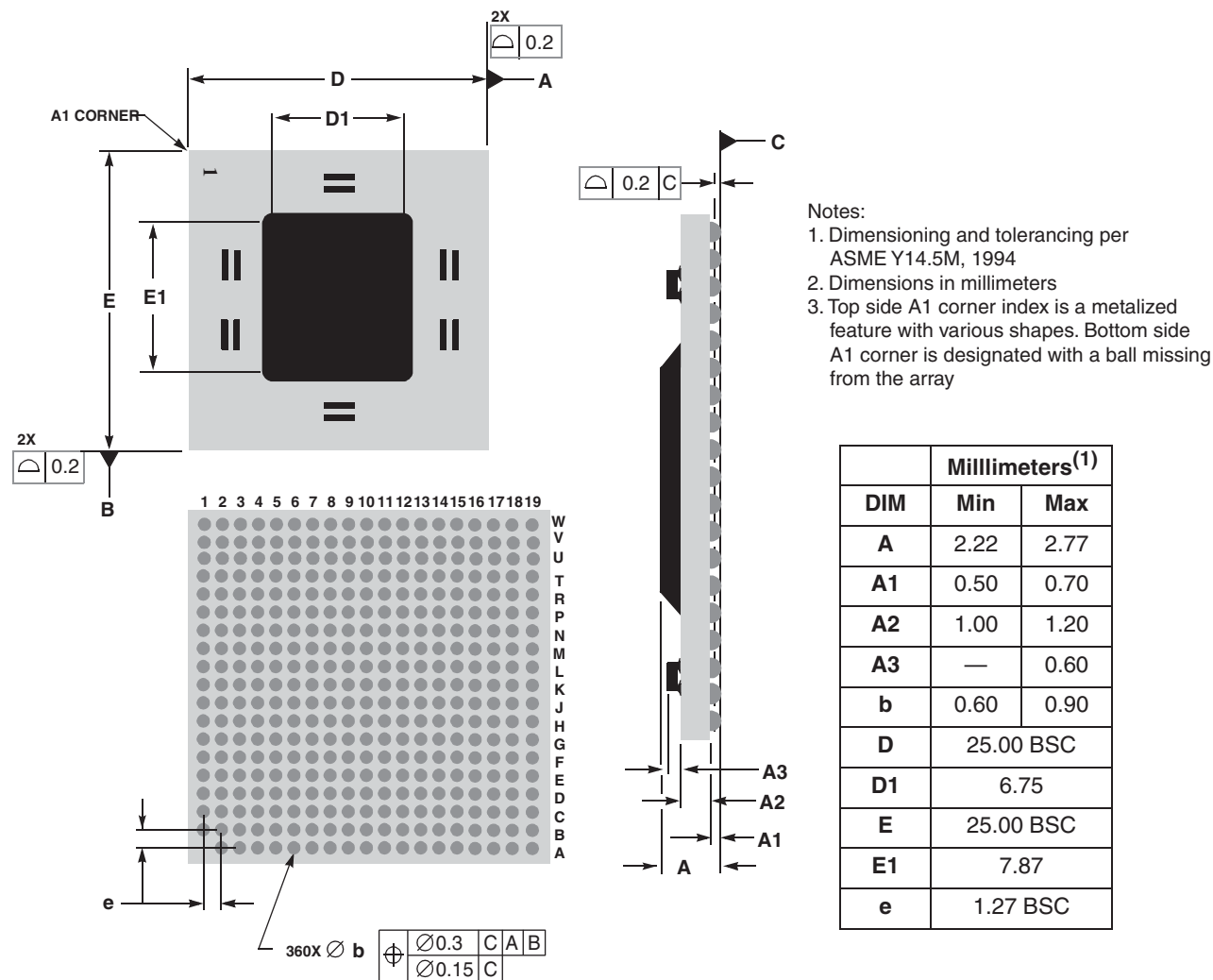
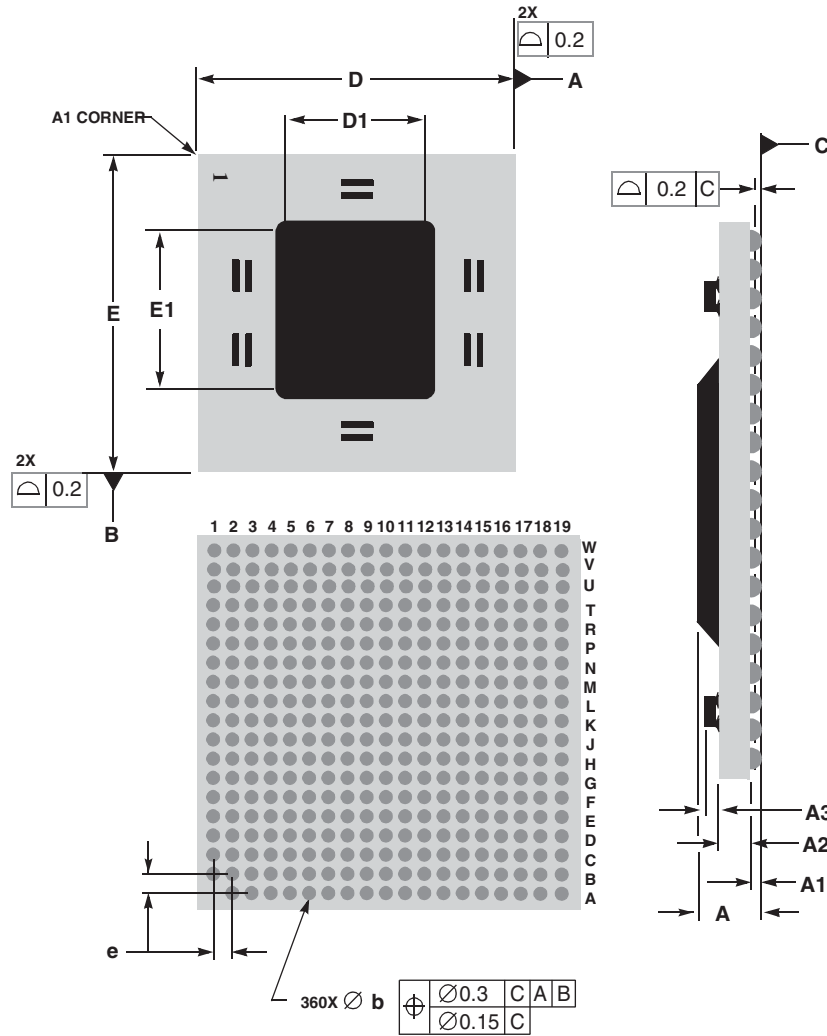

Figure 8-6. Mechanical Dimensions and Bottom Surface Nomenclature of the PC755 (PBGA-RoHS) (ZT)



- Notes:
1. Dimensioning and tolerancing per ASME Y14.5M, 1994
 2. Dimensions in millimeters
 3. Top side A1 corner index is a metalized feature with various shapes. Bottom side A1 corner is designated with a ball missing from the array

	Millimeters ⁽¹⁾	
DIM	Min	Max
A	2.22	2.77
A1	0.50	0.70
A2	1.00	1.20
A3	—	0.60
b	0.60	0.90
D	25.00 BSC	
D1	6.75	
E	25.00 BSC	
E1	7.87	
e	1.27 BSC	

8.2.2 Mechanical Dimensions of the PC755 CBGA Package

Figure 8-7 provides the mechanical dimensions and bottom surface nomenclature of the PC755, 360 CBGA package.

Figure 8-7. Mechanical Dimensions and Bottom Surface Nomenclature of PC755 (CBGA) (G)

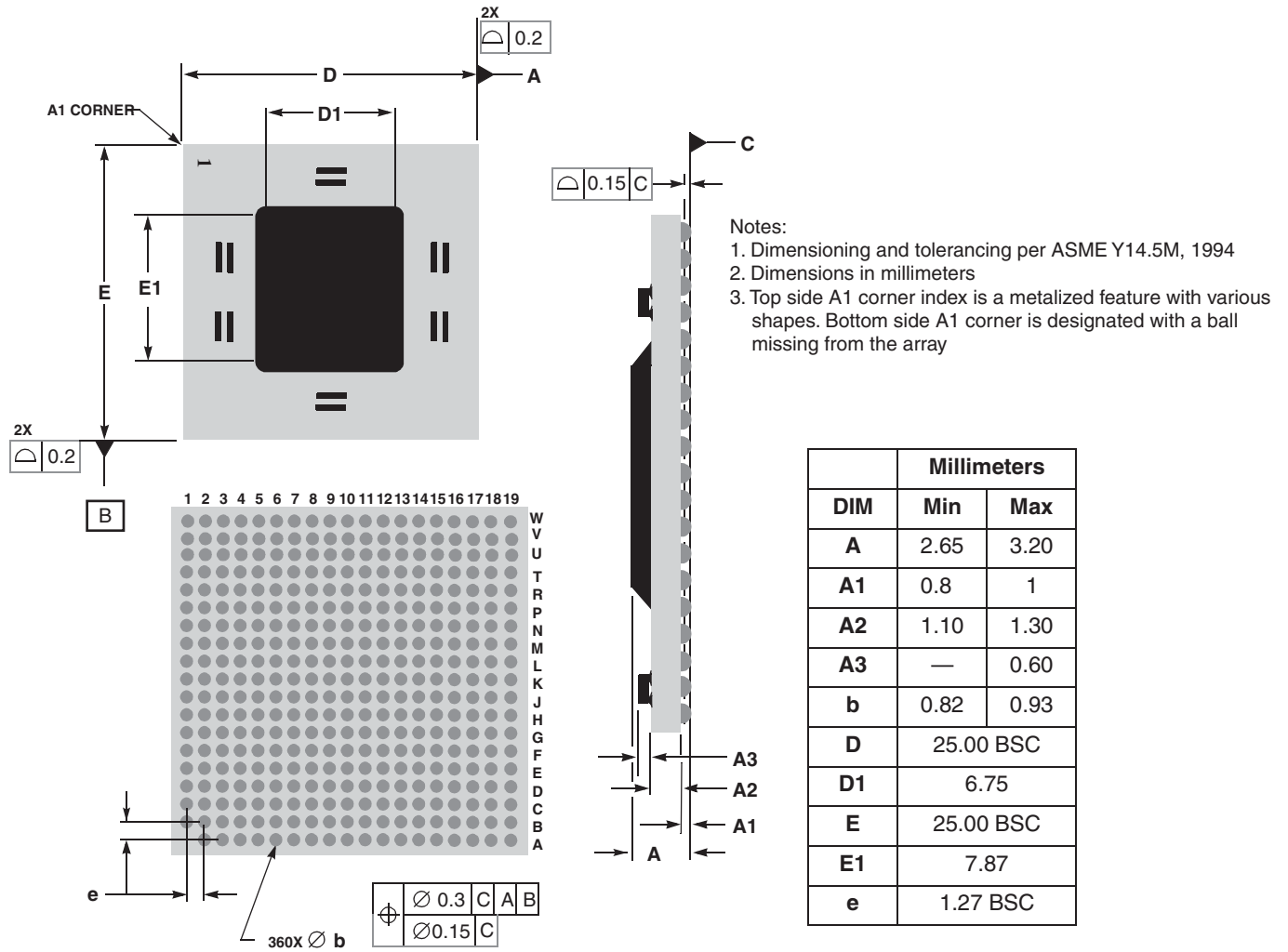

8.2.3 Mechanical Dimensions of the PC755 HiTCE Package

Figure 8-8 provides the mechanical dimensions and bottom surface nomenclature of the PC755, 360 HiTCE package.

Figure 8-8. Mechanical Dimensions and Bottom Surface Nomenclature of PC755 (HiTCE) (GH)

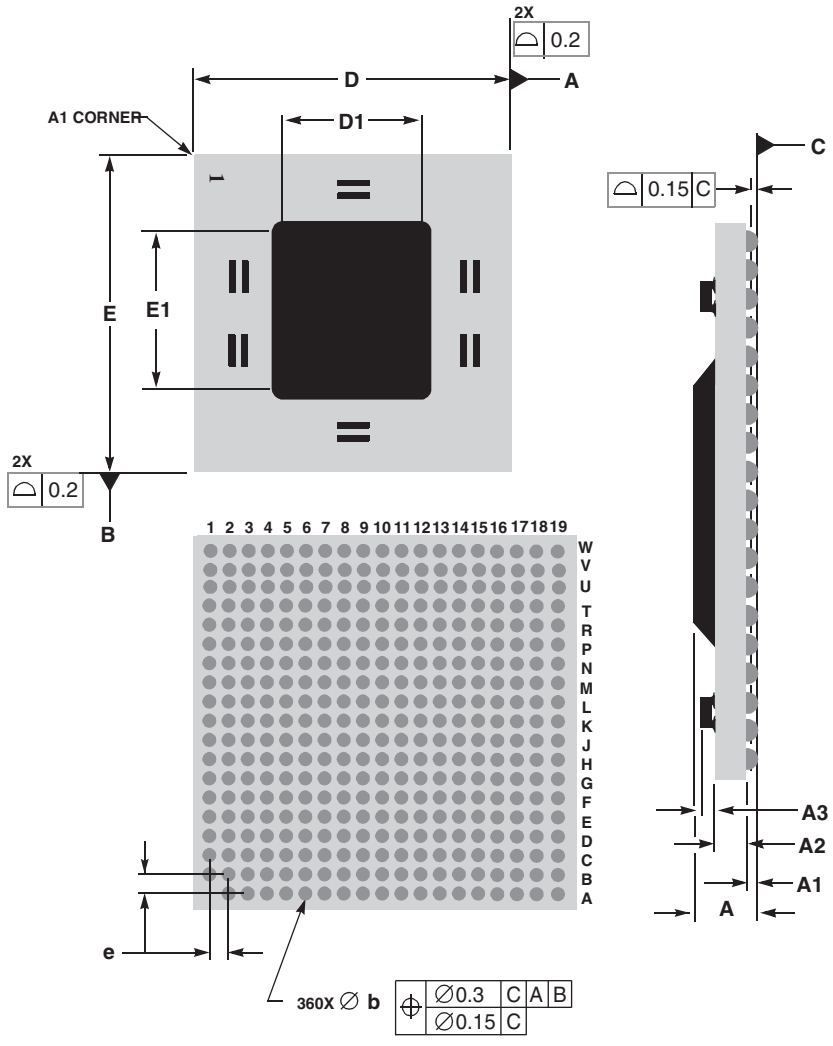

- Notes:
1. Dimensioning and tolerancing per ASME Y14.5M, 1994
 2. Dimensions in millimeters
 3. Top side A1 corner index is a metalized feature with various shapes. Bottom side A1 corner is designated with a ball missing from the array

Millimeters		
DIM	Min	Max
A	2.65	3.24
A1	0.8	1
A2	1.10	1.30
A3	—	0.60
b	0.82	0.93
D	25.00 BSC	
D1	6.75	
E	25.00 BSC	
E1	7.87	
e	1.27 BSC	

Figure 8-9. Mechanical Dimensions and Bottom Surface Nomenclature of PC755 (HiTCE-RoHS) (SH)

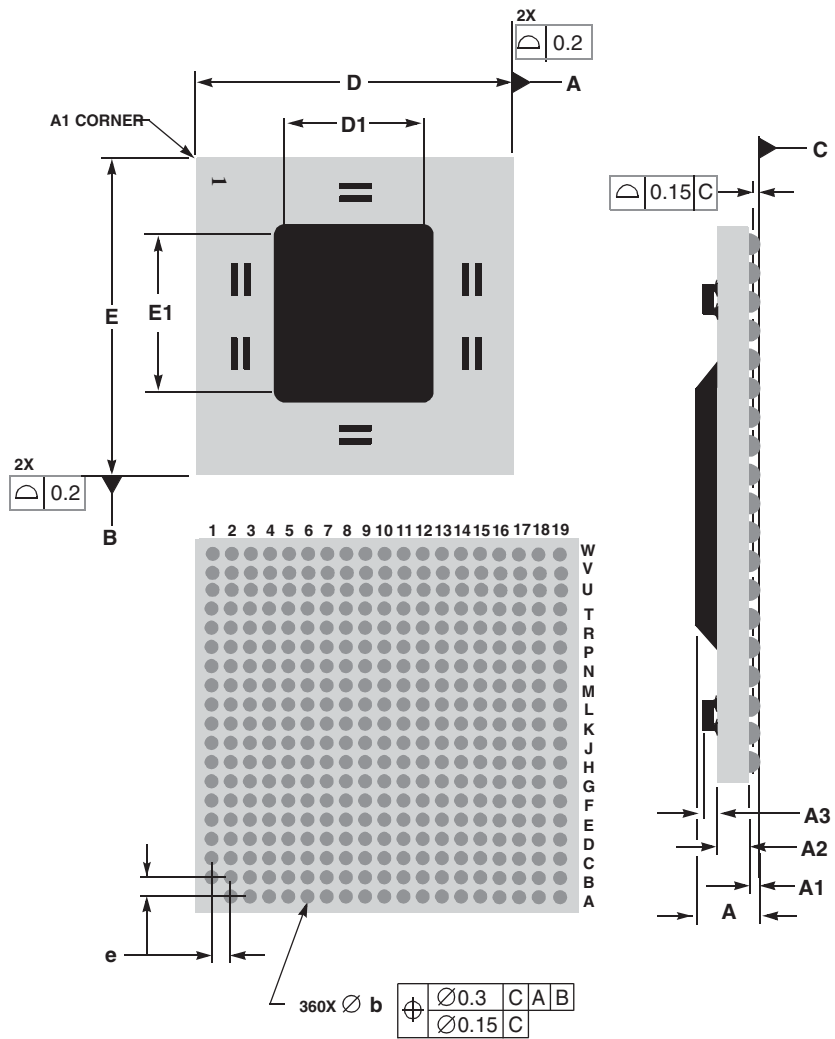

Notes:

1. Dimensioning and tolerancing per ASME Y14.5M, 1994
2. Dimensions in millimeters
3. Top side A1 corner index is a metalized feature with various shapes. Bottom side A1 corner is designated with a ball missing from the array

DIM	Millimeters	
	Min	Max
A	2.32	2.8
A1	0.46	0.6
A2	1.10	1.30
A3	—	0.60
b	0.6	0.93
D	25.00 BSC	
D1	6.75	
E	25.00 BSC	
E1	7.87	
e	1.27 BSC	

Figure 8-10. Mechanical Dimensions and Bottom Surface Nomenclature of PC755 (HiTCE-RoHS) (PH)

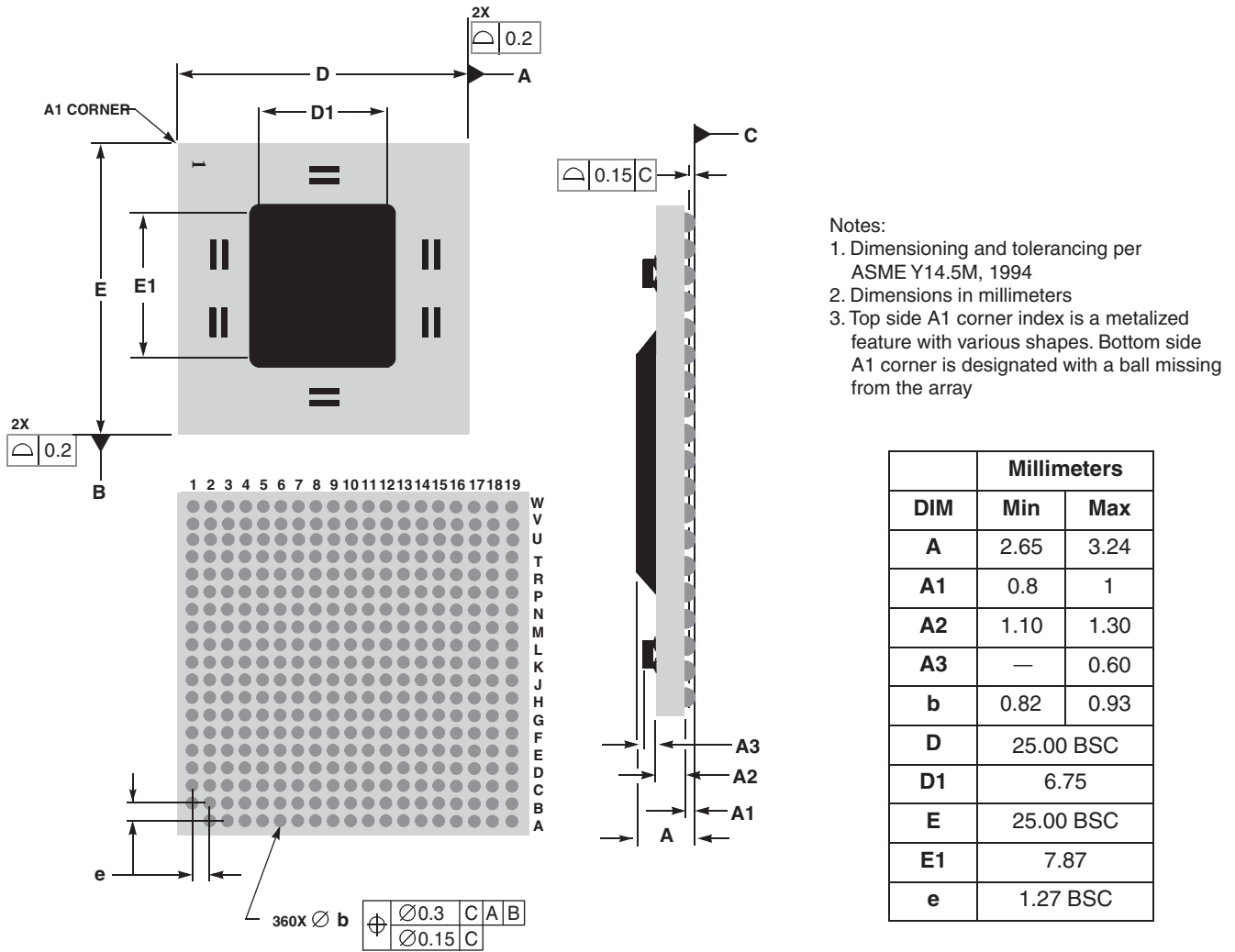
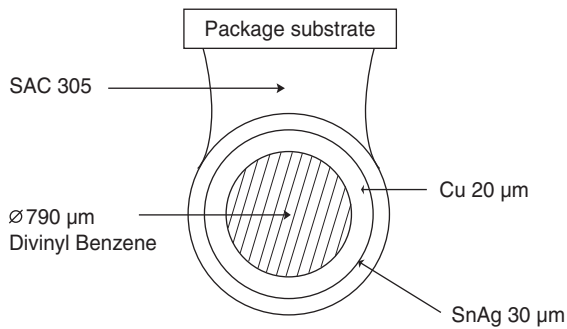

Figure 8-11. Polymer Solder Spheres Composition



8.2.4 Mechanical Dimensions of the PC755 CI-CGA Package

Figure 8-12 provides the mechanical dimensions and bottom surface nomenclature of PC755, 360 CI-CGA package.

Figure 8-12. Mechanical Dimensions and Bottom Surface Nomenclature of PC755 (CI-CGA) (GS)

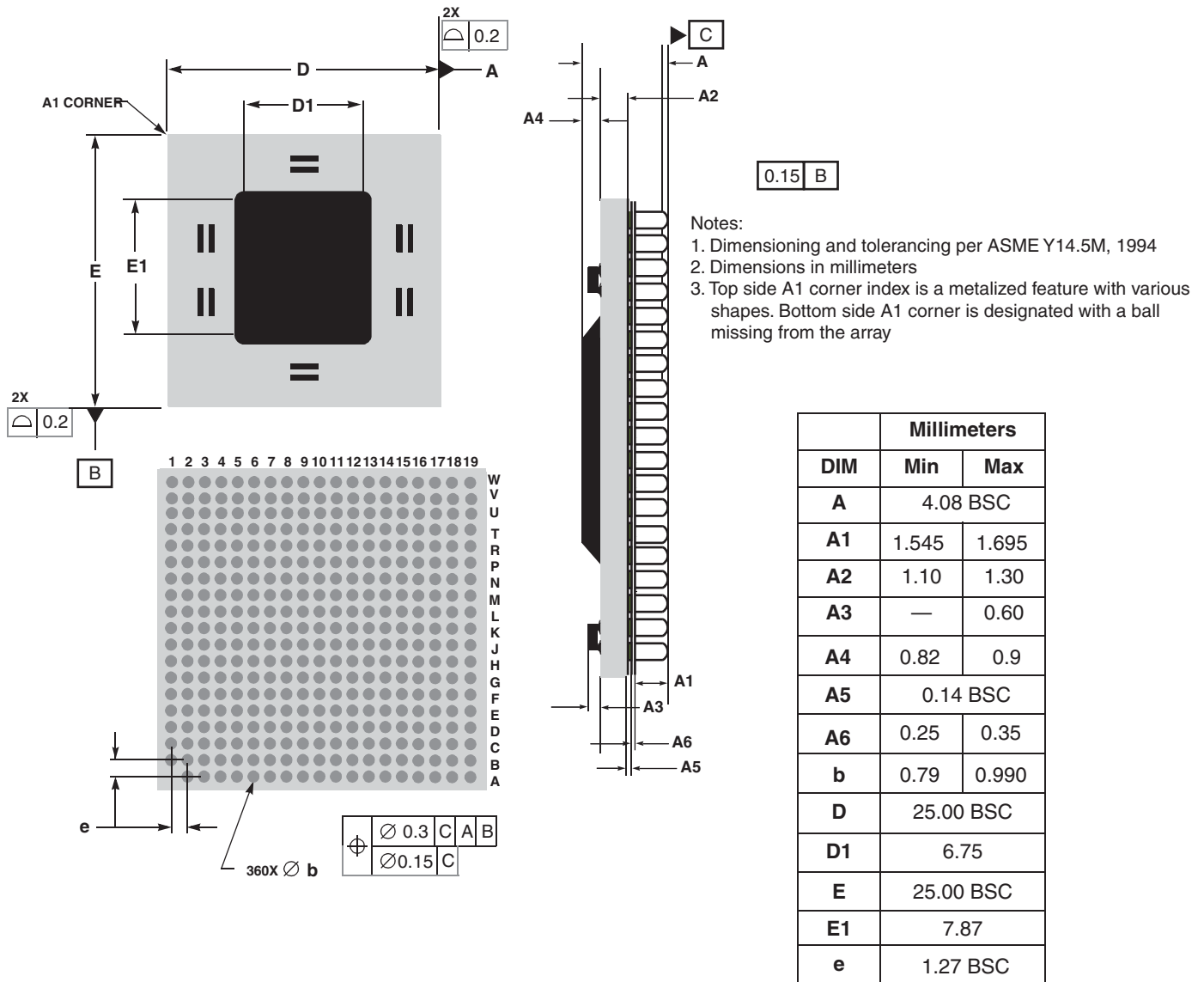

9. SYSTEM DESIGN INFORMATION

This section provides electrical and thermal design recommendations for successful application of the PC755.

9.1 PLL Configuration

The PC755 PLL is configured by the PLL_CFG[0:3] signals. For a given SYSCLK (bus) frequency, the PLL configuration signals set the internal CPU and VCO frequency of operation. These must be chosen such that they comply with Table 5-10 on page 13. Table 9-1 shows the valid configurations of these signals and an example illustrating the core and VCO frequencies resulting from various PLL configurations and example bus frequencies. In this example, shaded cells represent settings that, for a given SYSCLK frequency, result in core and/or VCO frequencies that do not comply with the 400-MHz column in Table 5-10.

Table 9-1. PC755 Microprocessor PLL Configuration Example for 400 MHz Parts

PLL_CFG [0-3]	Example Bus-to-Core Frequency in MHz (VCO Frequency in MHz)							
	Bus-to-Core Multiplier	Core-to VCO Multiplier	Bus 33 MHz	Bus 50 MHz	Bus 66 MHz	Bus 75 MHz	Bus 80 MHz	Bus 100 MHz
0100	2x	2x	–	–	–	–	–	200 (400)
1000	3x	2x	–	–	200 (400)	225 (450)	240 (480)	300 (600)
1110	3.5x	2x	–	–	233 (466)	263 (525)	280 (560)	350 (700)
1010	4x	2x	–	200 (400)	266 (533)	300 (600)	320 (640)	400 (800)
0111	4.5x	2x	–	225 (450)	300 (600)	338 (675)	360 (720)	–
1011	5x	2x	–	250 (500)	333 (666)	375 (750)	400 (800)	–
1001	5.5x	2x	–	275 (550)	366 (733)	–	–	–
1101	6x	2x	200 (400)	300 (600)	400 (800)	–	–	–
0101	6.5x	2x	216 (433)	325 (650)	–	–	–	–
0010	7x	2x	233 (466)	350 (700)	–	–	–	–
0001	7.5x	2x	250 (500)	375 (750)	–	–	–	–
1100	8x	2x	266 (533)	400 (800)	–	–	–	–

Table 9-1. PC755 Microprocessor PLL Configuration Example for 400 MHz Parts (Continued)

PLL_CFG [0–3]	Example Bus-to-Core Frequency in MHz (VCO Frequency in MHz)							
	Bus-to-Core Multiplier	Core-to VCO Multiplier	Bus 33 MHz	Bus 50 MHz	Bus 66 MHz	Bus 75 MHz	Bus 80 MHz	Bus 100 MHz
0110	10x	2x	333 (666)	–	–	–	–	–
0011	PLL off/bypass		PLL off, SYSCLK clocks core circuitry directly, 1x bus-to-core implied					
1111	PLL off		PLL off, no core clocking occurs					

- Notes:
1. PLL_CFG[0:3] settings not listed are reserved.
 2. The sample bus-to-core frequencies shown are for reference only. Some PLL configurations may select bus, core, or VCO frequencies which are not useful, not supported, or not tested for by the PC755; see [Section 5.3.1 "Clock AC Specifications" on page 13](#) for valid SYSCLK, core, and VCO frequencies.
 3. In PLL-bypass mode, the SYSCLK input signal clocks the internal processor directly, the PLL is disabled, and the bus mode is set for 1:1 mode operation. This mode is intended for factory use and emulator tool use only.
Note: The AC timing specifications given in this document do not apply in PLL-bypass mode.
 4. In PLL off mode, no clocking occurs inside the PC755 regardless of the SYSCLK input.

The PC755 generates the clock for the external L2 synchronous data SRAMs by dividing the core clock frequency of the PC755. The divided-down clock is then phase-adjusted by an on-chip delay-lock-loop (DLL) circuit and should be routed from the PC755 to the external RAMs. A separate clock output, L2SYNC_OUT is sent out half the distance to the SRAMs and then returned as an input to the DLL on pin L2SYNC_IN so that the rising-edge of the clock as seen at the external RAMs can be aligned to the clocking of the internal latches in the L2 bus interface.

The core-to-L2 frequency divisor for the L2 PLL is selected through the L2CLK bits of the L2CR register. Generally, the divisor must be chosen according to the frequency supported by the external RAMs, the frequency of the PC755 core, and the phase adjustment range that the L2 DLL supports. [Table 9-2](#) shows various example L2 clock frequencies that can be obtained for a given set of core frequencies. The minimum L2 frequency target is 80 MHz.

Table 9-2. Sample Core-to-L2 Frequencies

Core Frequency (MHz)	÷1	÷1.5	÷2	÷2.5	÷3
250	250	166	125	100	83
266	266	177	133	106	89
275	275	183	138	110	92
300	300	200	150	120	100
325	325	217	163	130	108
333	333	222	167	133	111
350	350	233	175	140	117
366	366	244	183	146	122
375	375	250	188	150	125
400	400	266	200	160	133

Note: The core and L2 frequencies are for reference only. Some examples may represent core or L2 frequencies which are not useful, not supported, or not tested for by the PC755; see [Section 5.3.3 "L2 Clock AC Specifications" on page 16](#) for valid L2CLK frequencies. The L2CR[L2SL] bit should be set for L2CLK frequencies less than 110 MHz.

9.2 PLL Power Supply Filtering

The AV_{DD} and $L2AV_{DD}$ power signals are provided on the PC755 to provide power to the clock generation PLL and L2 cache DLL, respectively. To ensure stability of the internal clock, the power supplied to the AV_{DD} input signal should be filtered of any noise in the 500 kHz to 10 MHz resonant frequency range of the PLL. A circuit similar to the one shown in [Figure 9-1](#) using surface mount capacitors with minimum Effective Series Inductance (ESL) is recommended. Consistent with the recommendations of Dr. Howard Johnson in *High Speed Digital Design: A Handbook of Black Magic* (Prentice Hall, 1993), multiple small capacitors of equal value are recommended over a single large value capacitor.

The circuit should be placed as close as possible to the AV_{DD} pin to minimize noise coupled from nearby circuits. An identical but separate circuit should be placed as close as possible to the $L2AV_{DD}$ pin. It is often possible to route directly from the capacitors to the AV_{DD} pin, which is on the periphery of the 360 BGA footprint, without the inductance of vias. The $L2AV_{DD}$ pin may be more difficult to route, but is proportionately less critical.

[Figure 9-1](#) shows the PLL power supply filter circuit.

Figure 9-1. PLL Power Supply Filter Circuit

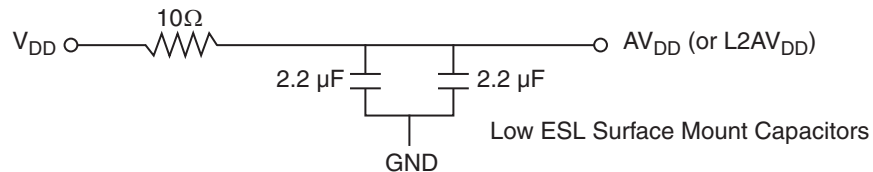

9.3 Decoupling Recommendations

Due to the PC755 dynamic power management feature, large address and data buses, and high operating frequencies, the PC755 can generate transient power surges and high frequency noise in its power supply, especially while driving large capacitive loads. This noise must be prevented from reaching other components in the PC755 system, and the PC755 itself requires a clean, tightly regulated source of power. Therefore, it is recommended that the system designer place at least one decoupling capacitor at each V_{DD} , OV_{DD} , and $L2OV_{DD}$ pin of the PC755. It is also recommended that these decoupling capacitors receive their power from separate V_{DD} , $(L2)OV_{DD}$, and GND power planes in the PCB, utilizing short traces to minimize inductance.

These capacitors should have a value of 0.01 or 0.1 μF . Only ceramic SMT (surface mount technology) capacitors should be used to minimize lead inductance, preferably 0508 or 0603 orientations where connections are made along the length of the part.

In addition, it is recommended that there be several bulk storage capacitors distributed around the PCB, feeding the V_{DD} , $L2OV_{DD}$, and OV_{DD} planes, to enable quick recharging of the smaller chip capacitors. These bulk capacitors should have a low ESR (equivalent series resistance) rating to ensure the quick response time necessary. They should also be connected to the power and ground planes through two vias to minimize inductance. Suggested bulk capacitors: 100–330 μF (AVX TPS tantalum or Sanyo OSCON).

9.4 Connection Recommendations

To ensure reliable operation, it is highly recommended to connect unused inputs to an appropriate signal level through a resistor. Unused active low inputs should be tied to OV_{DD} . Unused active high inputs should be connected to GND. All NC (no connect) signals must remain unconnected.

Power and ground connections must be made to all external V_{DD} , OV_{DD} , $L2OV_{DD}$, and GND pins of the PC755. Note that power must be supplied to $L2OV_{DD}$ even if the L2 interface of the PC755 will not be used; it is recommended to connect $L2OV_{DD}$ to OV_{DD} and $L2VSEL$ to $BVSEL$ if the L2 interface is unused. (This requirement does not apply to the PC745 since it has neither an L2 interface nor $L2OV_{DD}$ pins.)

9.5 Output Buffer DC Impedance

The PC755 60x and L2 I/O drivers are characterized over process, voltage, and temperature. To measure Z_0 , an external resistor is connected from the chip pad to $(L2)OV_{DD}$ or GND. Then, the value of each resistor is varied until the pad voltage is $(L2)OV_{DD}/2$ (see Figure 9-2).

The output impedance is the average of two components, the resistances of the pull-up and pull-down devices. When data is held low, SW2 is closed (SW1 is open), and R_N is trimmed until the voltage at the pad equals $(L2)OV_{DD}/2$. R_N then becomes the resistance of the pull-down devices. When data is held high, SW1 is closed (SW2 is open), and R_P is trimmed until the voltage at the pad equals $(L2)OV_{DD}/2$. R_P then becomes the resistance of the pull-up devices.

Figure 9-2 describes the driver impedance measurement circuit described above.

Figure 9-2. Driver Impedance Measurement Circuit

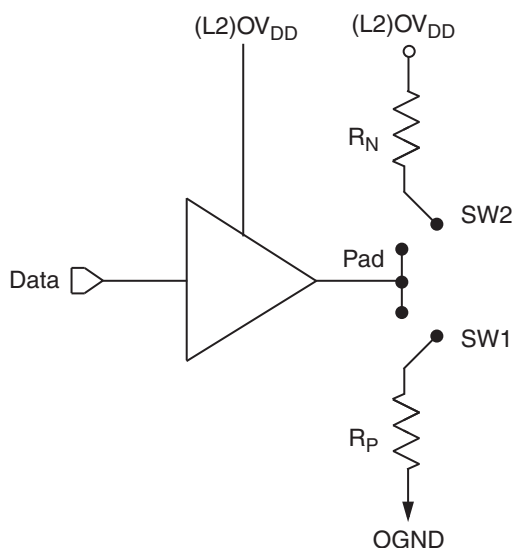

Alternately, the following is another method to determine the output impedance of the PC755. A voltage source, V_{force} , is connected to the output of the PC755 as shown in Figure 9-3. Data is held low, the voltage source is set to a value that is equal to $(L2)OV_{DD}/2$ and the current sourced by V_{force} is measured. The voltage drop across the pull-down device, which is equal to $(L2)OV_{DD}/2$, is divided by the measured current to determine the output impedance of the pull-down device, R_N . Similarly, the impedance of the pull-up device is determined by dividing the voltage drop of the pull-up, $(L2)OV_{DD}/2$, by the current sunk by the pull-up when the data is high and V_{force} is equal to $(L2)OV_{DD}/2$.

This method can be employed with either empirical data from a test setup or with data from simulation models, such as IBIS.

R_p and R_N are designed to be close to each other in value. Then $Z_0 = (R_p + R_N)/2$.

Figure 9-3 describes the alternate driver impedance measurement circuit.

Figure 9-3. Alternate Driver Impedance Measurement Circuit

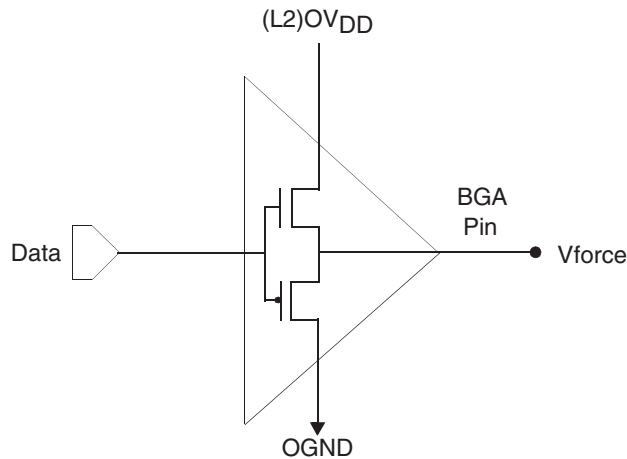

Table 9-3 summarizes the signal impedance results. The driver impedance values were characterized at 0°, 65°, and 105°C. The impedance increases with junction temperature and is relatively unaffected by bus voltage.

Table 9-3. Impedance Characteristics. $V_{DD} = 2.0V$, $OV_{DD} = 3.3V$, $T_c = 0 - 105^\circ C$

Impedance	Processor bus	L2 bus	Symbol	Unit
R_N	25–36	25–36	Z_0	Ω
R_p	26–39	26–39	Z_0	Ω

9.6 Pull-Up Resistor Requirements

The PC755 requires pull-up resistors (1–5 k Ω) on several control pins of the bus interface to maintain the control signals in the negated state after they have been actively negated and released by the PC755 or other bus masters. These pins are TS, ABB, AACK, ARTRY, DBB, DBWO, TA, TEA, and DBDIS. DRTRY should also be connected to a pull-up resistor (1–5 k Ω) if it will be used by the system; otherwise, this signal should be connected to HRESET to select NO-DRTRY mode (see the MPC750 RISC Microprocessor Family User’s Manual for more information on this mode).

Three test pins also require pull-up resistors (100Ω–1 kΩ). These pins are L1_TSTCLK, L2_TSTCLK, and LSSD_MODE. These signals are for factory use only and must be pulled up to OV_{DD} for normal machine operation.

In addition, $\overline{CKSTP_OUT}$ is an open-drain style output that requires a pull-up resistor (1–5 kΩ) if it is used by the system.

During inactive periods on the bus, the address and transfer attributes may not be driven by any master and may, therefore, float in the high-impedance state for relatively long periods of time. Since the PC755 must continually monitor these signals for snooping, this float condition may cause additional power draw by the input receivers on the PC755 or by other receivers in the system.

These signals can be pulled up through weak (10-kΩ) pull-up resistors by the system or may be otherwise driven by the system during inactive periods of the bus to avoid this additional power draw, but address bus pull-up resistors are not necessary for proper device operation. The snooped address and transfer attribute inputs are: A[0:31], AP[0:3], TT[0:4], TBST, and GBL.

The data bus input receivers are normally turned off when no read operation is in progress and, therefore, do not require pull-up resistors on the bus. Other data bus receivers in the system, however, may require pull-ups, or that those signals be otherwise driven by the system during inactive periods by the system. The data bus signals are: DH[0:31], DL[0:31], and DP[0:7].

If 32-bit data bus mode is selected, the input receivers of the unused data and parity bits will be disabled, and their outputs will drive logic zeros when they would otherwise normally be driven. For this mode, these pins do not require pull-up resistors, and should be left unconnected by the system to minimize possible output switching.

If address or data parity is not used by the system, and the respective parity checking is disabled through HIDEO, the input receivers for those pins are disabled, and those pins do not require pull-up resistors and should be left unconnected by the system. If all parity generation is disabled through HIDEO, then all parity checking should also be disabled through HIDEO, and all parity pins may be left unconnected by the system. The L2 interface does not require pull-up resistors.

9.7 JTAG Configuration Signals

Boundary scan testing is enabled through the JTAG interface signals. The \overline{TRST} signal is optional in the IEEE 1149.1 specification, but is provided on all processors that implement the PowerPC architecture. While it is possible to force the TAP controller to the reset state using only the TCK and TMS signals, more reliable power-on reset performance will be obtained if the \overline{TRST} signal is asserted during power-on reset. Because the JTAG interface is also used for accessing the common on-chip processor (COP) function, simply tying TRST to HRESET is not practical.

The COP function of these processors allows a remote computer system (typically, a PC with dedicated hardware and debugging software) to access and control the internal operations of the processor. The COP interface connects primarily through the JTAG port of the processor, with some additional status monitoring signals. The COP port requires the ability to independently assert \overline{HRESET} or \overline{TRST} in order to fully control the processor. If the target system has independent reset sources, such as voltage monitors, watchdog timers, power supply failures, or push-button switches, then the COP reset signals must be merged into these signals with logic.

The arrangement shown in [Figure 9-4](#) allows the COP port to independently assert $\overline{\text{HRESET}}$ or $\overline{\text{TRST}}$, while ensuring that the target can drive $\overline{\text{HRESET}}$ as well. If the JTAG interface and COP header will not be used, $\overline{\text{TRST}}$ should be tied to $\overline{\text{HRESET}}$ through a 0Ω isolation resistor so that it is asserted when the system reset signal ($\overline{\text{HRESET}}$) is asserted ensuring that the JTAG scan chain is initialized during power-on. While e2v recommends that the COP header be designed into the system as shown in [Figure 9-4](#), if this is not possible, the isolation resistor will allow future access to $\overline{\text{TRST}}$ in the case where a JTAG interface may need to be wired onto the system in debug situations.

The COP header shown in [Figure 9-4](#) adds many benefits: breakpoints, watchpoints, register and memory examination/modification, and other standard debugger features are possible through this interface, and can be as inexpensive as an unpopulated footprint for a header to be added when needed.

The COP interface has a standard header for connection to the target system, based on the 0.025" square-post 0.100" centered header assembly (often called a Berg header).

The connector typically has pin 14 removed as a connector key.

Figure 9-4. JTAG Interface Connection

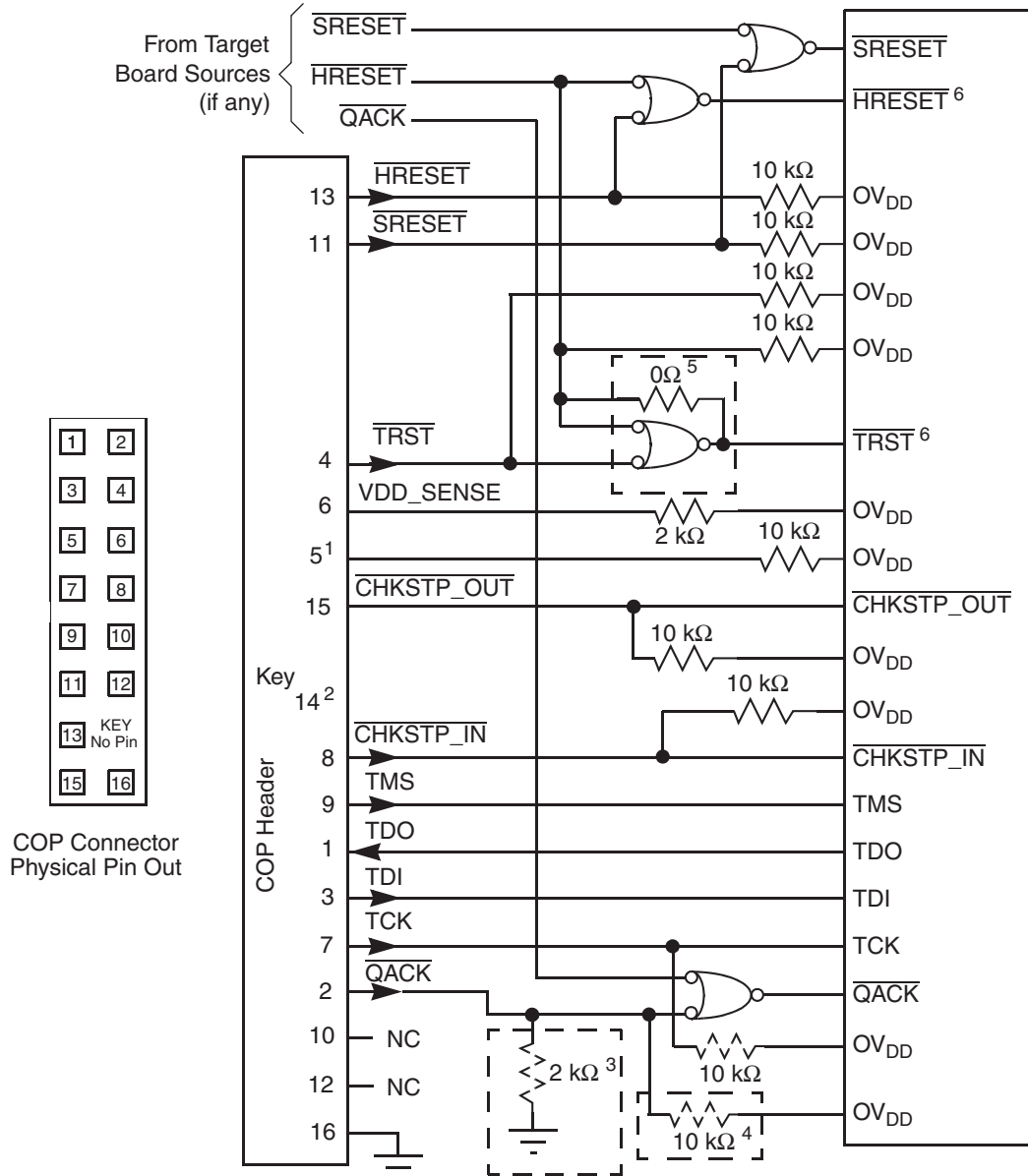

- Notes:
1. RUN/STOP, normally found on pin 5 of the COP header, is not implemented on the PC755. Connect pin 5 of the COP header to OV_{DD} with a 10-kΩ pull-up resistor.
 2. Key location; pin 14 is not physically present on the COP header.
 3. Component not populated. Populate only if debug tool does not drive \overline{QACK} .
 4. Populate only if debug tool uses an open-drain type output and does not actively deassert \overline{QACK} .
 5. If the JTAG interface is implemented, connect \overline{HRESET} from the target source to \overline{TRST} from the COP header through an AND gate to \overline{TRST} of the part. If the JTAG interface is not implemented, connect \overline{HRESET} from the target source to \overline{TRST} of the part through a 0-Ω isolation resistor.
 6. The COP port and target board should be able to independently assert \overline{HRESET} and \overline{TRST} to the processor in order to fully control the processor as shown above.

There is no standardized way to number the COP header shown in [Figure 9-4](#); consequently, many different pin numbers have been observed from emulator vendors. Some are numbered top-to-bottom then left-to-right, while others use left-to-right then top-to-bottom, while still others number the pins counter clockwise from pin 1 (as with an IC). Regardless of the numbering, the signal placement recommended in [Figure 9-5](#) is common to all known emulators.

The QACK signal shown in [Figure 9-4](#) is usually connected to the PCI bridge chip in a system and is an input to the PC755 informing it that it can go into the quiescent state. Under normal operation this occurs during a low-power mode selection. In order for COP to work, the PC755 must see this signal asserted (pulled down). While shown on the COP header, not all emulator products drive this signal. If the product does not, a pull-down resistor can be populated to assert this signal. Additionally, some emulator products implement open-drain type outputs and can only drive QACK asserted; for these tools, a pull-up resistor can be implemented to ensure this signal is deasserted when it is not being driven by the tool. Note that the pull-up and pull-down resistors on the QACK signal are mutually exclusive and it is never necessary to populate both in a system. To preserve correct power-down operation, QACK should be merged via logic so that it also can be driven by the PCI bridge.

9.8 Thermal Management Information

This section provides thermal management information for air-cooled applications. Proper thermal control design is primarily dependent on the system-level design: the heat sink, airflow, and thermal interface material. To reduce the die-junction temperature, heat sinks may be attached to the package by several methods: adhesive, spring clip to holes in the printed-circuit board or package, and mounting clip and screw assembly; see [Figure 9-5](#). This spring force should not exceed 5.5 pounds (2.5 kg) of force.

[Figure 9-5](#) describes the package exploded cross-sectional view with several heat sink options.

Figure 9-5. Package Exploded Cross-Sectional View with Several Heat Sink Options

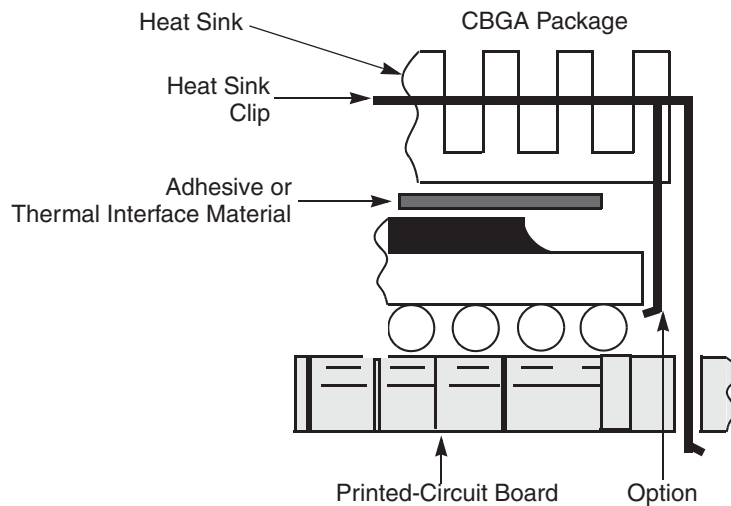

The board designer can choose between several types of heat sinks to place on the PC755.

Ultimately, the final selection of an appropriate heat sink depends on many factors, such as thermal performance at a given air velocity, spatial volume, mass, attachment method, assembly, and cost.

9.8.1 Internal Package Conduction Resistance

For the exposed-die packaging technology, shown in Table 5-6, the intrinsic conduction thermal resistance paths are as follows:

- The die junction-to-case (or top-of-die for exposed silicon) thermal resistance
- The die junction-to-ball thermal resistance

Figure 9-6 depicts the primary heat transfer path for a package with an attached heat sink mounted to a printed-circuit board.

Heat generated on the active side of the chip is conducted through the silicon, then through the heat sink attach material (or thermal interface material), and finally to the heat sink where it is removed by forced-air convection.

Since the silicon thermal resistance is quite small, for a first-order analysis, the temperature drop in the silicon may be neglected. Thus, the heat sink attach material and the heat sink conduction/convective thermal resistances are the dominant terms.

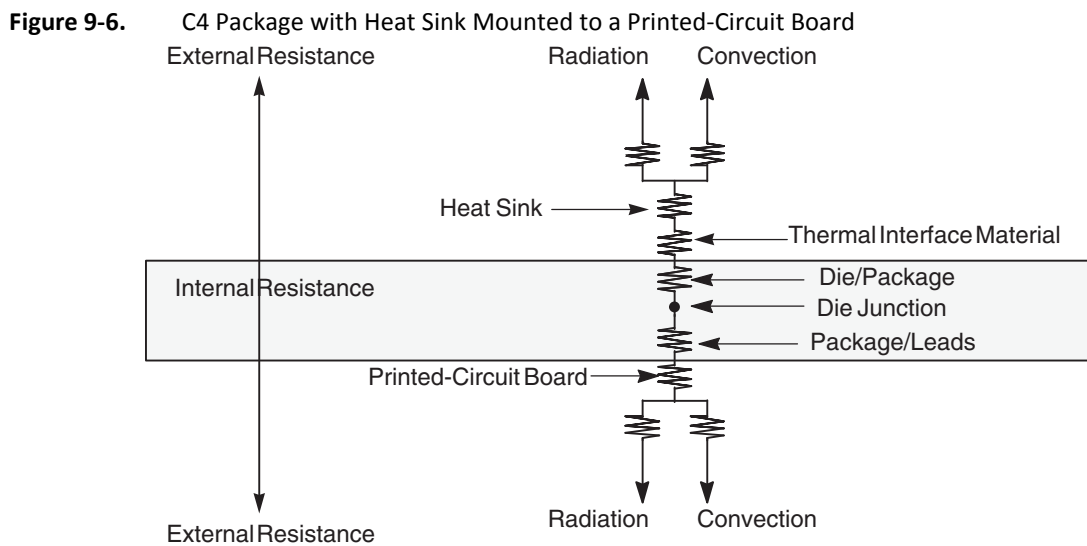

(Note the internal versus external package resistance.)

9.8.2 Adhesives and Thermal Interface Materials

A thermal interface material is recommended at the package lid-to-heat sink interface to minimize the thermal contact resistance. For those applications where the heat sink is attached by spring clip mechanism, [Figure 9-7](#) shows the thermal performance of three thin-sheet thermal-interface materials (silicone, graphite/oil, fluoroether oil), a bare joint, and a joint with thermal grease as a function of contact pressure. As shown, the performance of these thermal interface materials improves with increasing contact pressure. The use of thermal grease significantly reduces the interface thermal resistance. That is, the bare joint results in a thermal resistance approximately seven times greater than the thermal grease joint.

Heat sinks are attached to the package by means of a spring clip to holes in the printed-circuit board (see [Figure 9-5](#)). This spring force should not exceed 5.5 pounds of force. Therefore, the synthetic grease offers the best thermal performance, considering the low interface pressure. Of course, the selection of any thermal interface material depends on many factors: thermal performance requirements, manufacturability, service temperature, dielectric properties, cost, etc.

Figure 9-7 describes the thermal performance of select thermal interface materials.

Figure 9-7. Thermal Performance of Select Thermal Interface Materials

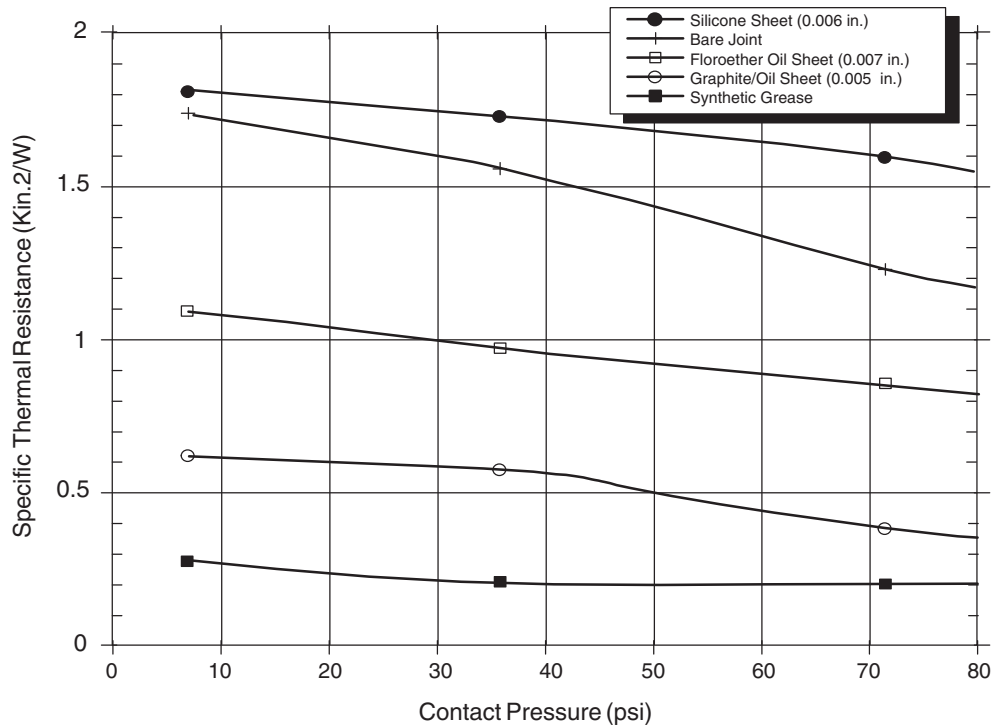

The board designer can choose between several types of thermal interface. Heat sink adhesive materials should be selected based on high conductivity, yet adequate mechanical strength to meet equipment shock/vibration requirements.

9.8.3 Heat Sink Selection Example

This section provides a heat sink selection example using one of the commercially-available heat sinks. For preliminary heat sink sizing, the die-junction temperature can be expressed as follows:

$$T_J = T_A + T_R + (\theta_{JC} + \theta_{INT} + \theta_{SA}) \times P_D$$

Where:

- T_J is the die-junction temperature
- T_A is the inlet cabinet ambient temperature
- T_R is the air temperature rise within the computer cabinet
- θ_{JC} is the junction-to-case thermal resistance
- θ_{INT} is the adhesive or interface material thermal resistance
- θ_{SA} is the heat sink base-to-ambient thermal resistance
- P_D is the power dissipated by the device

During operation the die-junction temperatures (T_J) should be maintained less than the value specified in Table 5-3 on page 9. The temperature of air cooling the component greatly depends on the ambient inlet air temperature and the air temperature rise within the electronic cabinet. An electronic cabinet inlet-air temperature (T_a) may range from 30° to 40°C.

The air temperature rise within a cabinet (T_r) may be in the range of 5° to 10°C. The thermal resistance of the thermal interface material (θ_{int}) is typically about 1°C/W. Assuming a T_a of 30°C, a T_r of 5°C, a CBGA package $R_{\theta_{jc}} < 0.1$, and a power consumption (P_d) of 5.0 W, the following expression for T_j is obtained:

$$T_j = 30^\circ\text{C} + 5^\circ\text{C} + (0.1^\circ\text{C/W} + 1.0^\circ\text{C/W} + \theta_{sa}) \times 5.0 \text{ W}$$

For a Thermalloy heat sink #2328B, the heat sink-to-ambient thermal resistance (θ_{sa}) versus airflow velocity is shown in Figure 9-8.

Assuming an air velocity of 0.5 m/s, we have an effective R_{sa} of 7°C/W, thus

$$T_j = 30^\circ\text{C} + 5^\circ\text{C} + (0.1^\circ\text{C/W} + 1.0^\circ\text{C/W} + 7^\circ\text{C/W}) \times 5.0 \text{ W},$$

resulting in a die-junction temperature of approximately 76°C which is well within the maximum operating temperature of the component.

Other heat sinks offered by Aavid Thermalloy, Alpha Novatech, The Bergquist Company, IERC, Chip Coolers, and Wakefield Engineering offer different heat sink-to-ambient thermal resistances, and may or may not need airflow.

Figure 9-8. Thermalloy #2328B Heat Sink-to-Ambient Thermal Resistance Versus Airflow Velocity

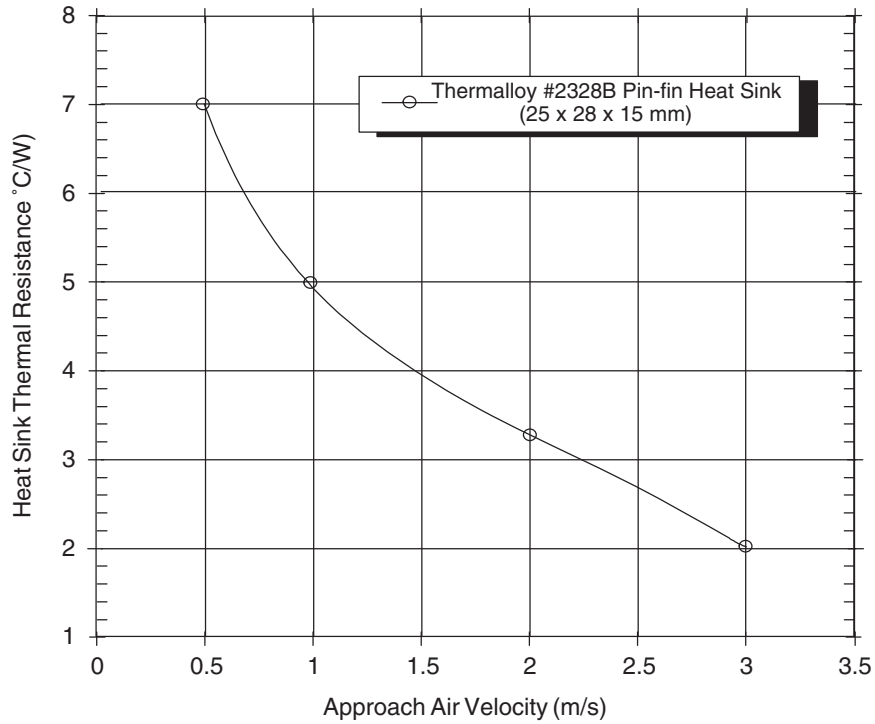

Though the die junction-to-ambient and the heat sink-to-ambient thermal resistances are a common figure-of-merit used for comparing the thermal performance of various microelectronic packaging technologies, one should exercise caution when only using this metric in determining thermal management because no single parameter can adequately describe three-dimensional heat flow. The final die-junction operating temperature, is not only a function of the component-level thermal resistance, but the system-level design and its operating conditions. In addition to the component's power consumption, a number of factors affect the final operating die-junction temperature: airflow, board population (local heat flux of adjacent components), heat sink efficiency, heat sink attach, heat sink placement, next-level interconnect technology, system air temperature rise, altitude, etc.

Due to the complexity and the many variations of system-level boundary conditions for today's microelectronic equipment, the combined effects of the heat transfer mechanisms (radiation, convection, and conduction) may vary widely. For these reasons, we recommend using conjugate heat transfer models for the board, as well as, system-level designs.

10. PREPARATION FOR DELIVERY

10.1 Packaging

Microcircuits are prepared for delivery in accordance with MIL-PRF-38535.

10.2 Certificate of Compliance

e2v offers a certificate of compliances with each shipment of parts, affirming the products are in compliance either with MIL-PRF-883 and guarantying the parameters not tested at temperature extremes for the entire temperature range.

10.3 Handling

MOS devices must be handled with certain precautions to avoid damage due to accumulation of static charge. Input protection devices have been designed in the chip to minimize the effect of static buildup. However, the following handling practices are recommended:

1. Devices should be handled on benches with conductive and grounded surfaces
2. Ground test equipment, tools and operator
3. Do not handle devices by the leads
4. Store devices in conductive foam or carriers
5. Avoid use of plastic, rubber, or silk in MOS areas
6. Maintain relative humidity above 50 percent if practical
7. For CI-CGA packages, use specific tray to take care of the highest height of the package compared with the normal CBGA

11. ORDERING INFORMATION

Ordering information for the devices fully covered by this specification document is provided in “Ordering Information” Note that the individual part numbers correspond to a maximum processor core frequency. For available frequencies, contact your local e2v sales office. In addition to the processor frequency, the part numbering scheme also includes an application modifier which may specify special application conditions. Each part number also contains a revision code which refers to the die mask revision number. Table 11-1 lists the part numbers which do not fully conform to the specifications of this document. These special part numbers require an additional document called a hardware specifications addendum.

Table 11-1 provides the e2v part numbering nomenclature for the PC755 and PC745 devices fully addressed by this document.

Table 11-1. Ordering Information

xx	745 755	x	y	xx	x	nnn	L	E
Product Code ⁽¹⁾	Part Identifier	Process Descriptor	Temperature Range T _c /T _j ⁽¹⁾	Package ⁽¹⁾	Screening Level	Max Internal Processor Speed ⁽¹⁾ (MHz)	Bus Divider (to be confirmed)	Revision Level ⁽¹⁾
PC(X) ⁽²⁾	755	B : HiP4DP slow C : HiP4DP fast	M : -55 °C/+125 °C V : -40 °C/+110 °C C : 0 °C/+105 °C ⁽³⁾	ZT : RoHS FC-PBGA ZF : FC-PBGA G : CBGA GS : Ci-CGA GH : HiTCE CBGA SH : RoHS CBGA PH : RoHS CBGA	U: Upscreening Test Blank: Standard	300 350 366 400	L: Any valid PLL configuration	E: Rev. 2.8
PC(X) ⁽²⁾	745	B : HiP4DP slow C : HiP4DP fast	M : -55 °C/+125 °C V : -40 °C/+110 °C C : 0 °C/+105 °C ⁽³⁾	ZT : RoHS FC-PBGA ZF : FC-PBGA G : CBGA GS : Ci-CGA GH : HiTCE BGA SH : RoHS HiTCE BGA PH : RoHS HiTCE BGA	U: Upscreening Test Blank: Standard	300 350	L: Any valid PLL configuration	E: Rev. 2.8

- Notes:
1. For availability of the different versions, contact your local e2v sales office.
 2. The letter X in the part number designates a product that has not been fully qualified by e2v and long term reliability is not guaranteed. For more information a Reliability Test Report is available upon request. Reliability and application acceptability of a PCX part-number is solely based on customer's procuring organization, based on its evaluation of the device and the specific qualification levels in association with the intended application.
 3. For Commercial Temperature range (C), range is shown as Tj/Tj

12. DEFINITIONS

12.1 Life Support Applications

These products are not designed for use in life support appliances, devices, or systems where malfunction of these products can reasonably be expected to result in personal injury. e2v customers using or selling these products for use in such applications do so at their own risk and agree to fully indemnify e2v for any damages resulting from such improper use or sale.

13. DOCUMENT REVISION HISTORY

Table 13-1 provides a revision history for this hardware specification.

Table 13-1. Revision History

Revision Number	Date	Substantive Change(s)
0828O	01/2017	Table 11-1, "Ordering Information," on page 60 : Updated note 2
0828N	07/2016	Updated ordering information
0828M	02/2016	Added Commercial Temperature range (C) Added RoHS FC-PBGA package description (ZT) Updated ordering information : New temperature range and package added
0828L	06/2013	Recommended values for PC755 option 400 MHz update (see Table 5-3, "Recommended Operating Conditions⁽¹⁾," on page 9)
0828K	01/2013	Rewriting of the whole specification Ordering information update: PC745 option 400 MHz removed
0828J	05/2008	Added RoHS compliant version for both PC745 and PC755: Added Table 8-1 on page 33 and Table 8-2 on page 33 presenting package parameter and solder spheres composition for all package type for both PC745 and PC755 HiTCE products. Added Figure 8-3 on page 36 , Figure 8-10 on page 44 and Figure 8-12 on page 45 : Mechanical drawing of HiTCE RoHS version of both PC745/755 Added Figure 8-11 on page 44 Updated Figure 11-1 on page 60 : Ordering information with HiTCE RoHS versions.
0828I	01/2008	Change A1 specification from 0.79/0.99 mm to 0.8/1 mm in Figure 8-7 on page 41 and Figure 8-9 on page 43 . Change T _J to T _C on page 2 and 9 .
0828H	02/2007	Name change from Atmel to e2v
2138G	04/2006	Increased power specification for 350 MHz full-power mode in Table 5-5 on page 11 Updated ordering information to new Template
2138F	05/2005	Added HiTCE package for Power Architecture 745 Removed phrase "for the ceramic ball grid array (CBGA) package" from Section on page 65 ; this information applies to devices in all packages Figure 14-5 on page 75 : updated COP Connector Diagram to recommend a weak pull-up resistor on TCK
2138E	10/2004	Product specification release subsequent to product qualification Motorola changed to Freescale
2138D	06/2003	Preliminary β -site

Table of Contents

	FEATURES	1
	Description	1
	Screening	1
1	Overview	2
2	Features	3
3	General Parameters	6
4	Detailed Specifications	6
	4.1 Applicable Documents	6
5	Electrical and Thermal Characteristics	7
	5.1 DC Electrical Characteristics	7
	5.2 Thermal Characteristics	11
	5.3 AC Electrical Characteristics	13
6	Pin Assignments	25
7	Pinout Listings	27
8	Package Mechanical Data	33
	8.1 Package Parameters for the PC745	33
	8.2 Package Parameter for the PC755	38
9	System Design Information	46
	9.1 PLL Configuration	46
	9.2 PLL Power Supply Filtering	48
	9.3 Decoupling Recommendations	48
	9.4 Connection Recommendations	49
	9.5 Output Buffer DC Impedance	49
	9.6 Pull-Up Resistor Requirements	50
	9.7 JTAG Configuration Signals	51
	9.8 Thermal Management Information	54
10	Preparation for Delivery	59
	10.1 Packaging	59
	10.2 Certificate of Compliance	59
	10.3 Handling	59

11 Ordering Information 60

12 Definitions 61

 12.1 Life Support Applications 61

13 Document Revision History 61

Table of Contents i