

# HARWIN

## Instruction Sheet

IS-38

Gecko Assembly Tool Z125-902

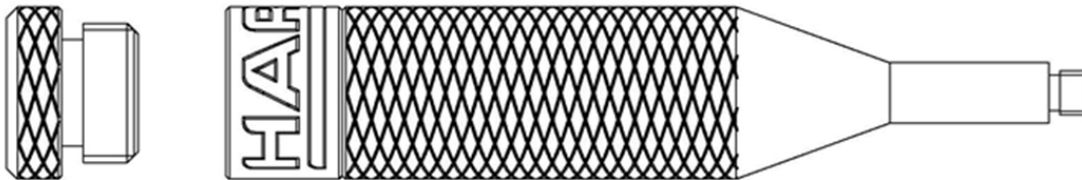

### Insertion/Extraction Tool Holder

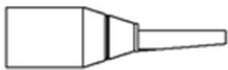

**Z125-920** Insertion Tool (for insulation from  $\text{Ø}0.65\text{mm}$  to  $\text{Ø}0.8\text{mm}$ )

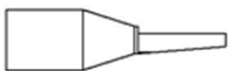

**Z125-921** Insertion Tool (for insulation up to  $\text{Ø}0.65\text{m}$ )



**Z125-922** Extraction Tool (Female contacts)

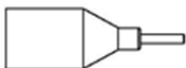

**Z125-923** Extraction Tool (Male contacts)

## **INSERTION PROCEDURE – CABLED CONTACTS**

1. Strip the wire and crimp the contact on to the wire, ensuring that the correct part is used (see Instruction Sheet IS-37, Hand Crimp Tool Z125-900).
2. Ensure all parts (housing and crimp contacts) are clean and ready for final assembly.
3. Select the appropriate insertion tool for the wire size in use and attach to the handle. The different tools can be found by unscrewing the cap at the end of the handle (see above for tool identification).
4. Place the crimped contact partially into the housing. The correct position is reached when approximately 0.4-1mm of contact protrudes (see Figure 2).
5. Place the insertion tool over the wire, with the wire sitting in the groove and the tool resting on the back of the crimped contact (see Figure 1).
6. To complete the assembly, push firmly on the rear of the contact while ensuring the tool remains perpendicular to the housing face. There will be an audible click when the contact is correctly seated within the housing.
7. Repeat steps 4 to 6 until the housing is populated as required. Care should be taken not to damage any contacts. It is recommended that the housing be supported by a small fixture (like an unpopulated mating housing in a vice) or a hard flat surface. Do not support the housing on any latches fitted, or pressure exerted on inserting the contacts will bend the latches.

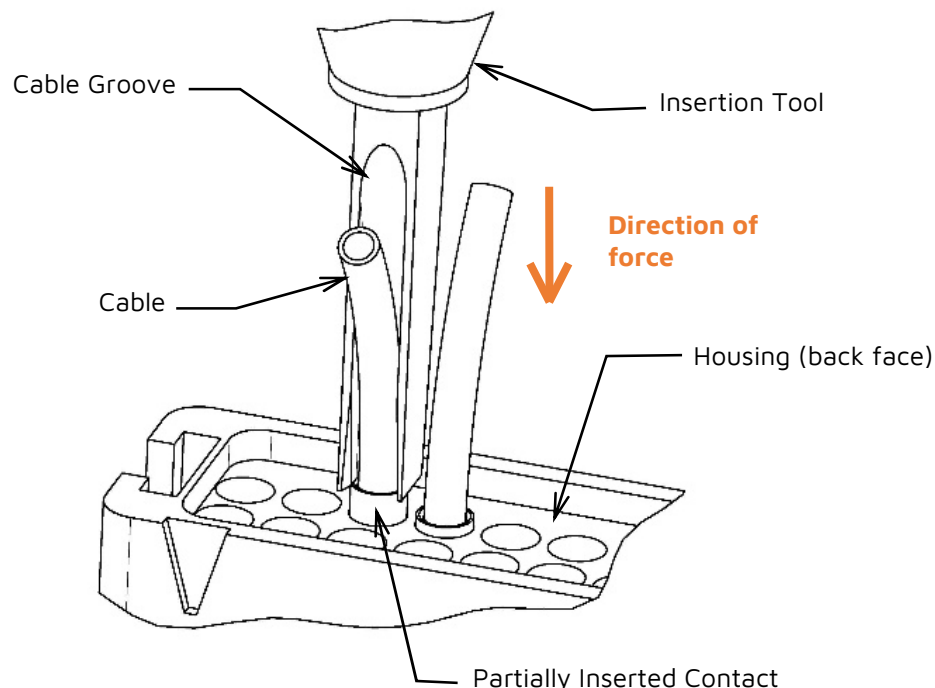

**Figure 1 – Insertion Diagram for Crimped Contacts**

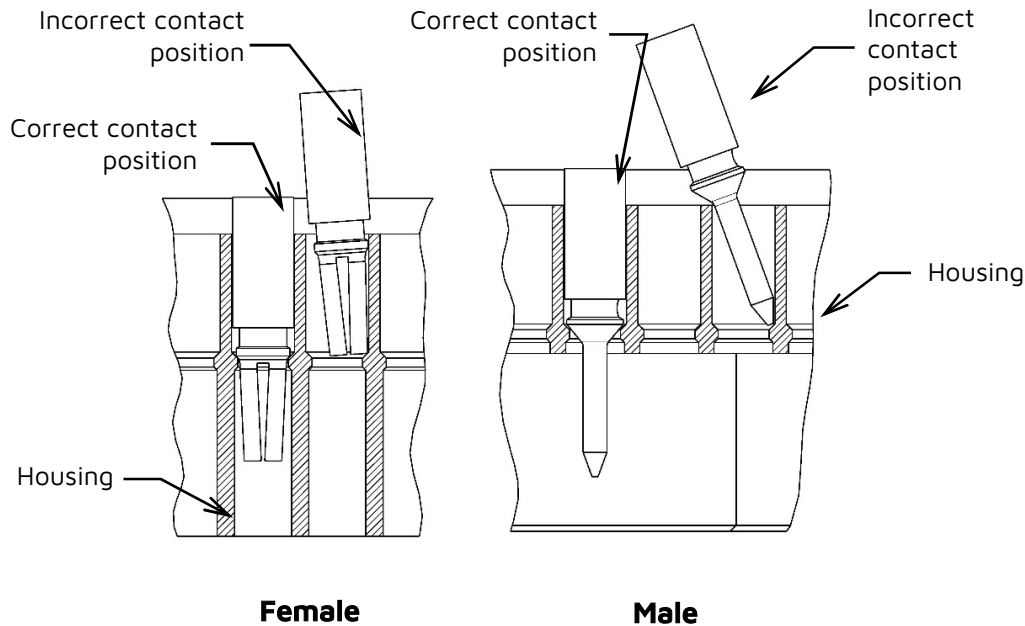

**Figure 2 - Female and male contact position prior to final 'click-in'**

## **EXTRACTION PROCEDURE - CABLED CONTACTS**

To remove a contact from the housing, select the appropriate Extraction Tool from the handle and attach as before. Place this tool over the mating end of the contact and push firmly. Care should be taken to keep the tool perpendicular to the housing face, otherwise damage to the housing or contact could occur.

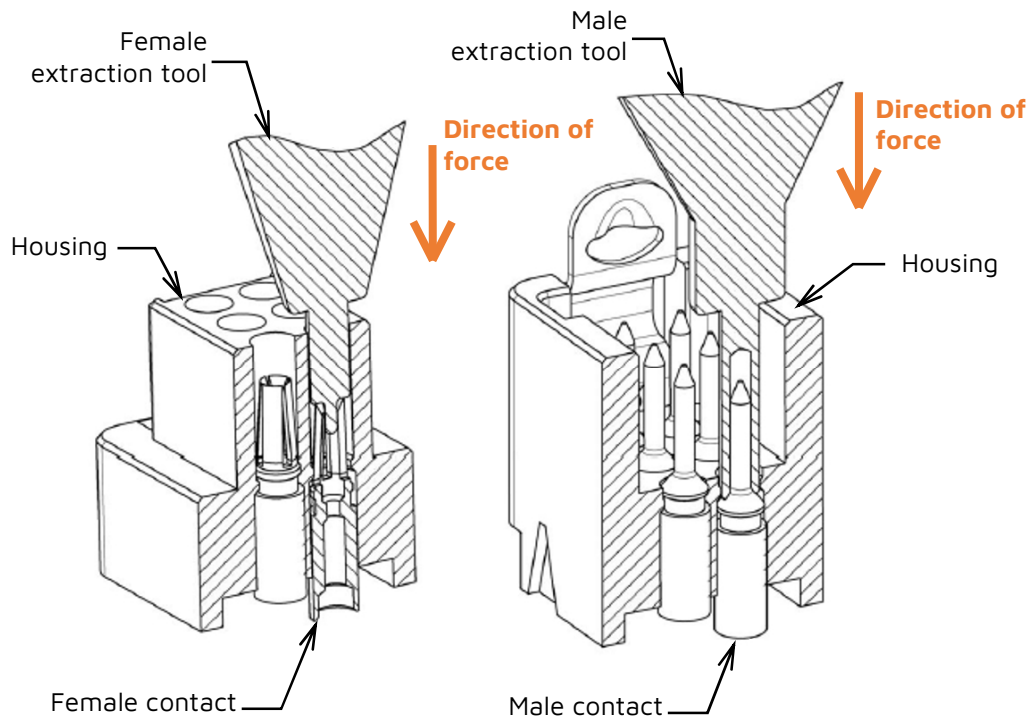

**Figure 3 - Extraction of male and female crimp contacts**

**Notes:**

- A different tool tip is required for female and male contacts.
- Following the extraction of contacts from their housing, re-use of that housing is not advised. It is recommended that a new housing be used to ensure the integrity of the contact retention in the housing.

**INSERTION PROCEDURE – POLARIZING/BLANKING PLUG (G125-0200005)**

1. Ensure all parts (housing and polarising/blanking parts) are clean and ready for final assembly.
2. Select the 30/32AWG insertion tip and attach to the handle. The different tools can be found by unscrewing the cap at the end of the handle (see Page 1 for tool identification).
3. Place the polarizing/blanking plug partially into the housing. The correct position is reached when approximately 0.4-1mm of plug protrudes (see Figure 4).
4. Place the insertion tool over the plug, with the tool sitting square on the back of the plug (see Fig. 5).
5. To complete the assembly, push firmly on the rear of the plug while ensuring the tool remains perpendicular to the housing face. There will be an audible click when the plug is correctly seated within the housing.
6. Repeat steps 3 to 5 until the housing is populated as required. Care should be taken not to damage any polarizing/blanking plugs. It is recommended that the housing be supported by a small fixture (like an unpopulated mating housing in a vice) or a hard flat surface. Do not support the housing on any latches fitted, or pressure exerted when inserting the plugs will bend the latches.

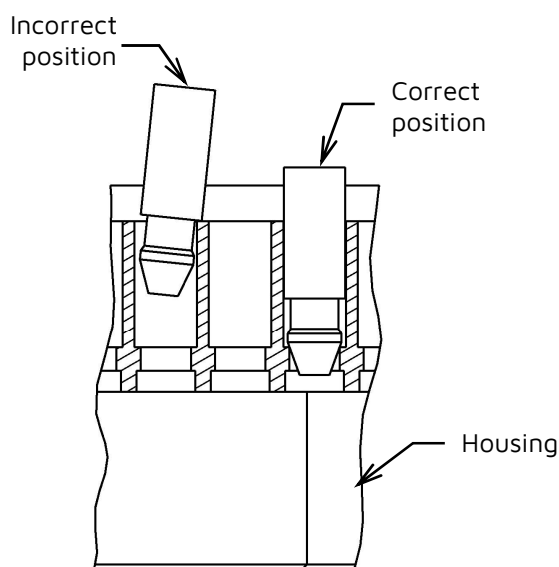

**Figure 4 – Polarizing/blanking plug prior to final 'click-in'**

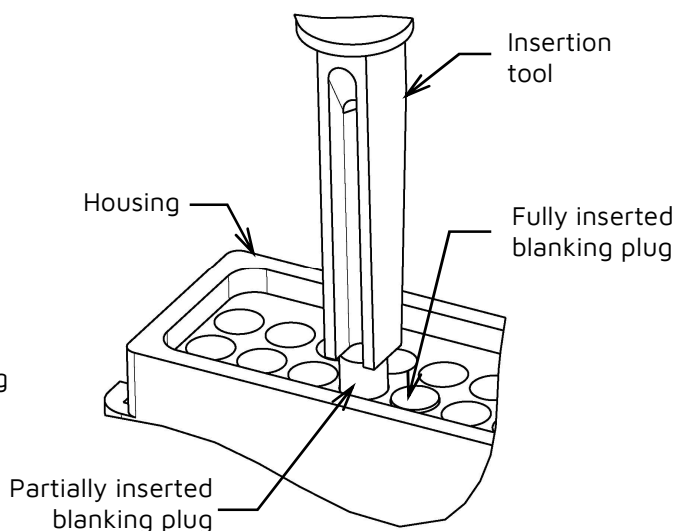

**Figure 5 – Insertion of polarizing/blanking plug into housing**

## **EXTRACTION PROCEDURE – POLARIZING/BLANKING PLUG**

To remove a polarizing/blanking plug, select the male contact extraction tip from the handle and attach as before. Place the tool over the mating end of the plug and push firmly. Care should be taken to keep the tool perpendicular to the housing face, otherwise damage to the housing or plug could occur.

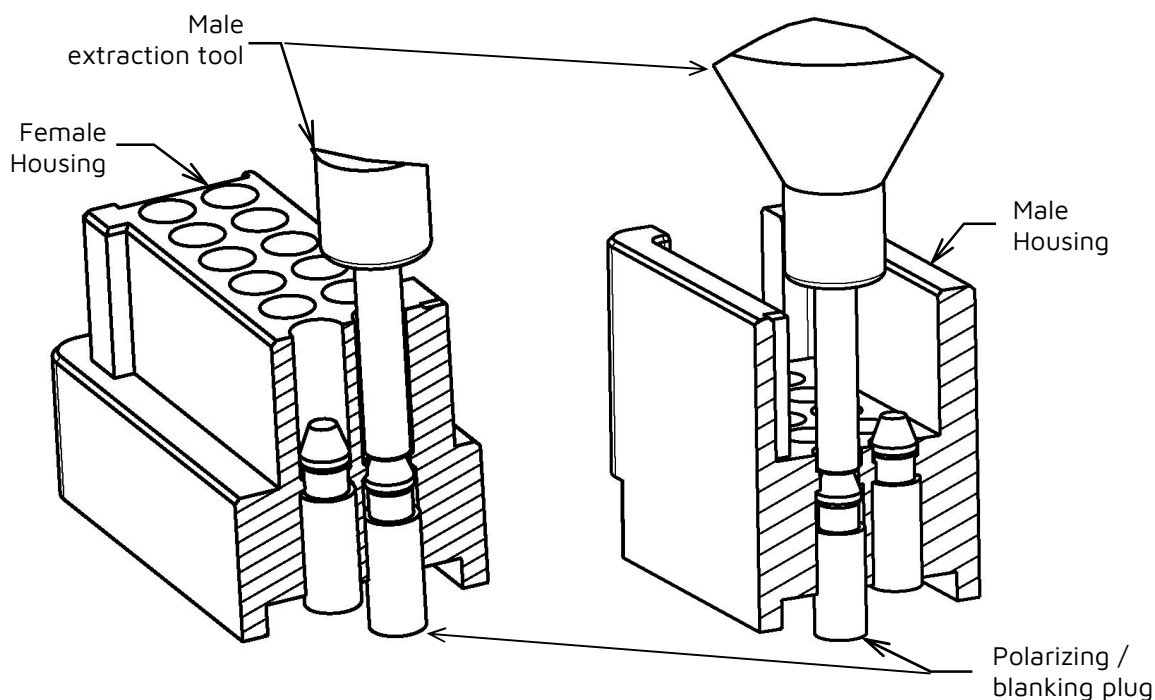

**Figure 6 – Extraction of polarising plug**

### **Notes:**

- The polarizing/blanking plug is used for additional keying or polarisation when used in place of any male/female crimp contacts.
- **When using the polarizing/blanking plug in female crimp connectors, you must remove the equivalent pin from the male mating connector (see Figures 7 and 8).**
- A male PCB connector pin can be removed from the underside of the connector with small needle-nose pliers. Be careful not to damage the surrounding pins.
- Following the extraction of a polarizing/blanking plug from the housing, re-use of that housing is not advised. It is recommended that a new housing be used to ensure the integrity of the retention features.

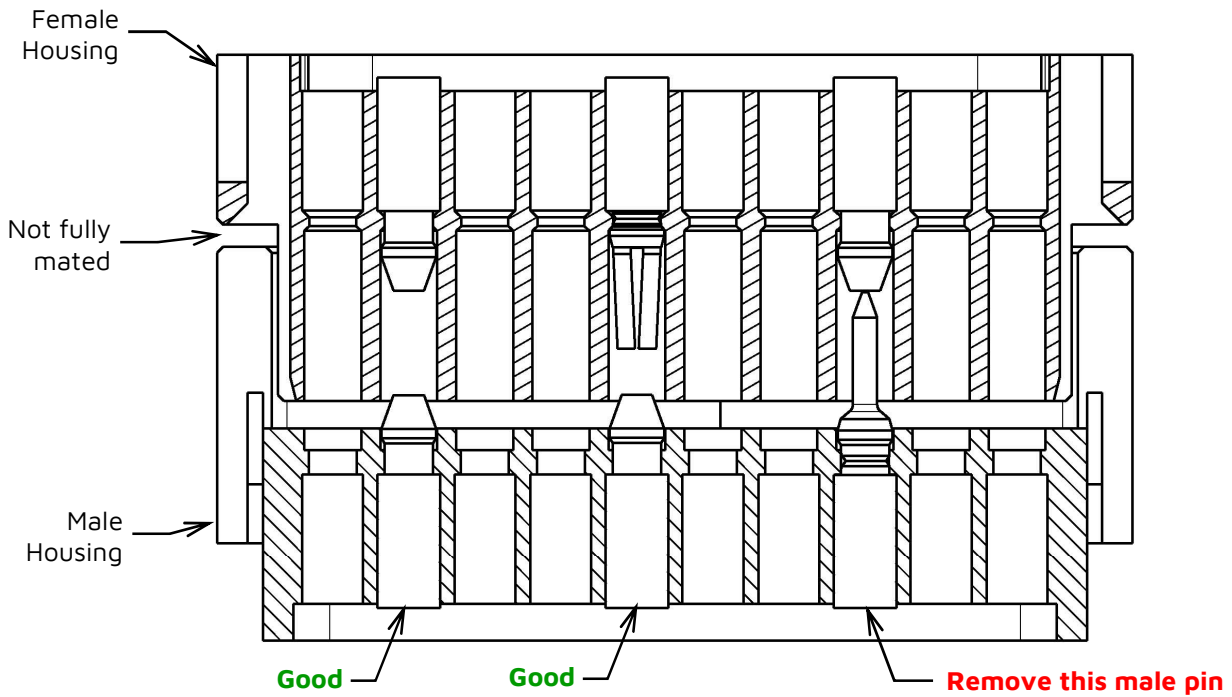

**Figure 7 - Polarizing/blanking plug in female and male cable connectors preventing full connection**

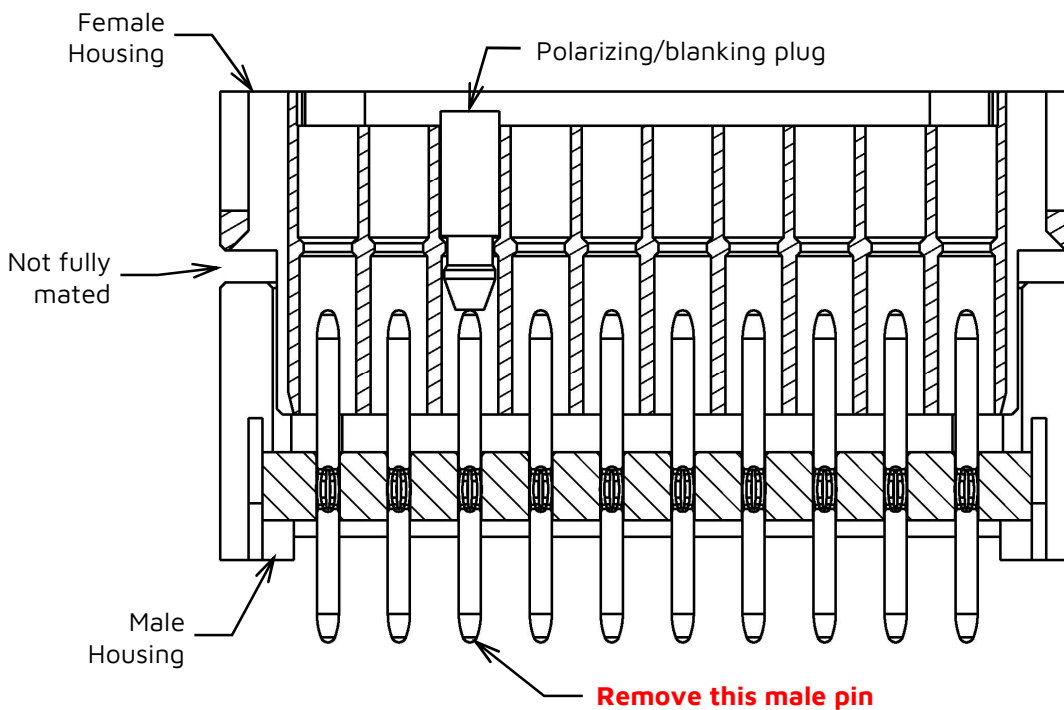

**Figure 8 - Polarizing/blanking plug in female cable connector preventing full connection with male PCB connector**