

### DESCRIPTION

The MA732 detects the absolute angular position of a permanent magnet, typically a diametrically magnetized cylinder on a rotating shaft. Fast data acquisition and processing provide accurate angle measurements at speeds from 0rpm to 60,000rpm. The digital filtering is adjustable to optimize control loop performance when used in servo applications.

The MA732 supports a wide range of magnetic field strengths and spatial configurations. Both end-of-shaft and off-axis (side-shaft mounting) configurations are supported.

The MA732 features magnetic field strength detection with programmable thresholds to allow sensing of the magnet position relative to the sensor for creation of functions, such as the sensing of axial movements or for diagnostics.

On-chip, non-volatile memory provides storage for configuration parameters, including the reference zero angle position, ABZ encoder settings, and magnetic field detection thresholds.

### FEATURES

- 9-Bit to 14-Bit Resolution Absolute Angle Encoder
- Contactless Sensing for Long Life
- SPI Serial Interface for Digital Angle Readout and Chip Configuration
- Incremental 12-Bit ABZ Quadrature Encoder Interface with Programmable Pulses per Turn from 1 to 1024
- 14-Bit PWM Output
- Programmable Magnetic Field Strength Detection for Diagnostic Checks
- 3.3V, 12mA Supply
- -40°C to +125°C Operating Temperature
- Available in a QFN-16 (3mmx3mm) Package

### APPLICATIONS

- General-Purpose Angle Measurements
- High-Resolution Angle Encoders
- Automotive Angle
- Robotics

All MPS parts are lead-free, halogen-free, and adhere to the RoHS directive. For MPS green status, visit the MPS website under Quality Assurance. "MPS", the MPS logo, and "Simple, Easy Solutions" are registered trademarks of Monolithic Power Systems, Inc. or its subsidiaries.

### TYPICAL APPLICATION

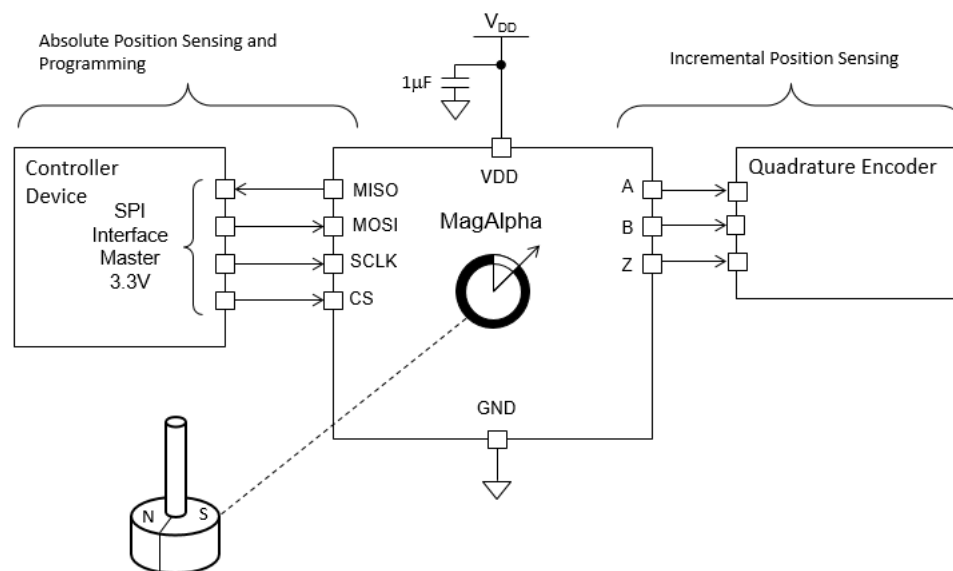

### ORDERING INFORMATION

Part Number*	Package	Top Marking
MA732GQ	QFN-16 (3mmx3mm)	See Below

\* For Tape & Reel, add suffix -Z (e.g. MA732GQ-Z).

### TOP MARKING

**BKBY**  
**LLL**

BKB: Product code of MA732GQ  
Y: Year code  
LLL: Lot number

### PACKAGE REFERENCE

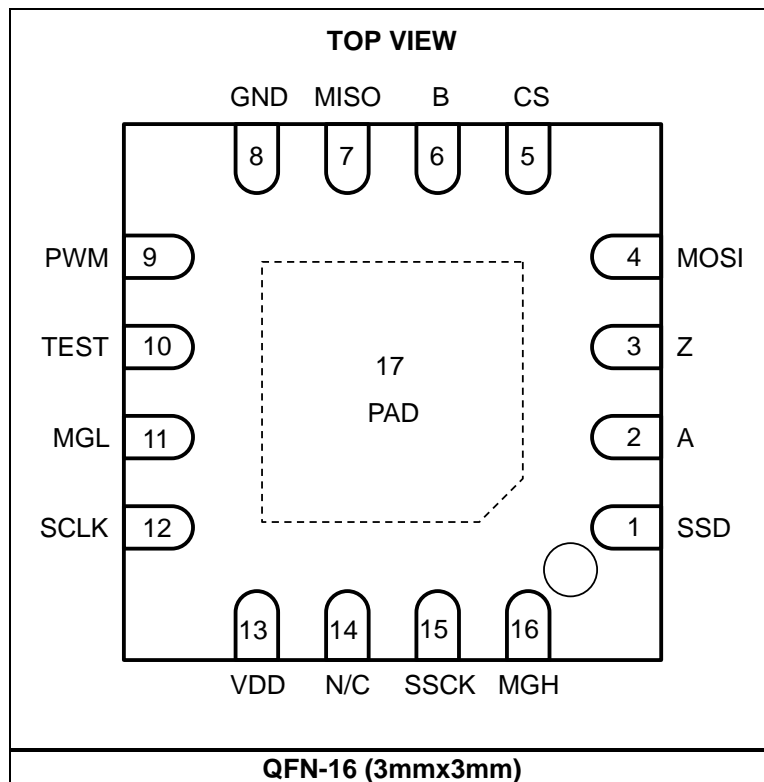

**PIN FUNCTIONS**

Pin #	Name	Description
1	SSD	<b>Data out (SSI).</b>
2	A	<b>Incremental output.</b>
3	Z	<b>Incremental output.</b>
4	MOSI	<b>Data in (SPI).</b> MOSI has an internal pull-down resistor.
5	CS	<b>Chip select (SPI).</b> CS has an internal pull-up resistor.
6	B	<b>Incremental output.</b>
7	MISO	<b>Data out (SPI).</b> MISO has an internal pull-down resistor that is enabled at a high-impedance state.
8	GND	<b>Supply ground.</b>
9	PWM	<b>PWM output.</b>
10	TEST	<b>Factory use only.</b> Connect TEST to ground.
11	MGL	<b>Digital output indicating field strength below MGLT level.</b>
12	SCLK	<b>Clock (SPI).</b> Internal pull down.
13	VDD	<b>3.3V supply.</b>
14	NC	<b>No connection.</b> Leave NC unconnected.
15	SSCK	<b>Clock (SSI).</b> Internal pull down.
16	MGH	<b>Digital output indicating field strength above MGHT level.</b>

**ABSOLUTE MAXIMUM RATINGS** <sup>(1)</sup>

Supply voltage .....	-0.5V to +4.6V
Input pin voltage (V <sub>I</sub> ) .....	-0.5V to +6.0V
Output pin voltage (V <sub>O</sub> ) .....	-0.5V to +4.6V
Continuous power dissipation (T <sub>A</sub> = +25°C) <sup>(2)</sup>	2.0W
Junction temperature .....	125°C
Lead temperature .....	260°C
Storage temperature .....	-65°C to +150°C

<b>Thermal Resistance</b> <sup>(3)</sup>	<b>θ<sub>JA</sub></b>	<b>θ<sub>JC</sub></b>
QFN-16 (3mmx3mm) .....	50.....	12... °C/W

**Notes:**

- 1) Exceeding these ratings may damage the device.
- 2) The maximum allowable power dissipation is a function of the maximum junction temperature T<sub>J</sub> (MAX), the junction-to-ambient thermal resistance θ<sub>JA</sub>, and the ambient temperature T<sub>A</sub>. The maximum allowable continuous power dissipation at any ambient temperature is calculated by P<sub>D</sub> (MAX) = (T<sub>J</sub> (MAX) - T<sub>A</sub>) / θ<sub>JA</sub>.
- 3) Measured on JESD51-7, 4-layer PCB.

**ELECTRICAL CHARACTERISTICS**

Parameter	Symbol	Condition	Min	Typ	Max	Units
<b>Recommended Operating Conditions</b>						
Supply voltage	V <sub>DD</sub>		3.0	3.3	3.6	V
Supply current	I <sub>DD</sub>	From -40°C to +125°C	10.2	11.7	13.8	mA
Operating temperature	T <sub>op</sub>		-40		125	°C
Applied magnetic field	B		40	60		mT

## GENERAL CHARACTERISTICS

VDD = 3.3V, 45mT < B < 100mT, temp = -40°C to +125°C, unless otherwise noted.

Parameter	Symbol	Condition	Min	Typ	Max	Units
<b>Absolute Output – Serial</b>						
Effective resolution ( $\pm 3\sigma$ )		Filter window $\tau = 64\mu\text{s}$	9.0	9.8	10.5	bits
		Filter window $\tau = 16\text{ms}$	13.0	13.8	14.5	bits
Noise RMS		Filter window $\tau = 64\mu\text{s}$	0.04	0.07	0.12	deg
		Filter window $\tau = 16\text{ms}$	0.003	0.004	0.007	deg
Refresh rate			850	980	1100	kHz
Data output length			16		16	bits
<b>Response Time</b>						
Power-up time <sup>(4)</sup>		Filter window $\tau = 64\mu\text{s}$			0.6	ms
		Filter window $\tau = 16\text{ms}$			260	ms
Latency <sup>(4)</sup>		Constant speed propagation delay	8		10	$\mu\text{s}$
Filter cutoff frequency <sup>(4)</sup>	$f_{\text{cutoff}}$	Filter window $\tau = 64\mu\text{s}$		6		kHz
	$f_{\text{cutoff}}$	Filter window $\tau = 16\text{ms}$		23		Hz
<b>Accuracy</b>						
INL at 25°C		At room temperature over the full field range		0.7		deg
INL between -40°C and +125°C <sup>(5)</sup>		Over the full temperature range and field range		1.1		deg
<b>Output Drift</b>						
Temperature induced drift at room temperature <sup>(5)</sup>				0.015		deg/°C
Temperature induced variation <sup>(5)</sup>		From 25°C to 85°C		0.5		deg
		From 25°C to 125°C		1.0		deg
Magnetic field induced <sup>(5)</sup>				0.005		deg/mT
Voltage supply induced <sup>(5)</sup>					0.3	deg/V
<b>Absolute Output – PWM</b>						
PWM frequency	$f_{\text{PWM}}$		840	970	1090	Hz
PWM resolution			13	13.8	14.0	bits
<b>Incremental Output – ABZ</b>						
ABZ update rate				16		MHz
Resolution – edges per turn		Programmable	4		4096	
Pulses per channel per turn	PPT + 1	Programmable	1		1024	
ABZ hysteresis <sup>(5)</sup>	H	Programmable	0.08		2.8	deg
Systematic jitter <sup>(5)</sup>		For PPT = 1023, up to 60mT			11	%
		For PPT = 127			7	%

**GENERAL CHARACTERISTICS (continued)**
**VDD = 3.3V, 45mT < B < 100mT, temp = -40°C to +125°C, unless otherwise noted.**

Parameter	Symbol	Condition	Min	Typ	Max	Units
<b>Magnetic Field Detection Thresholds</b>						
Accuracy <sup>(5)</sup>				5		mT
Hysteresis <sup>(5)</sup>	MagHys			6		mT
Temperature drift <sup>(5)</sup>				-600		ppm/°C
<b>Digital I/O</b>						
Input high voltage	V <sub>IH</sub>		2.5		5.5	V
Input low voltage	V <sub>IL</sub>		-0.3		0.8	V
Output low voltage <sup>(5)</sup>	V <sub>OL</sub>	I <sub>OL</sub> = 4mA			0.4	V
Output high voltage <sup>(5)</sup>	V <sub>OH</sub>	I <sub>OH</sub> = 4mA	2.4			V
Pull-up resistor	R <sub>PU</sub>		46	66	97	kΩ
Pull-down resistor	R <sub>PD</sub>		43	55	97	kΩ
Rising edge slew rate <sup>(4)</sup>	T <sub>R</sub>	CL = 50pF		0.7		V/ns
Falling edge slew rate <sup>(4)</sup>	T <sub>F</sub>	CL = 50pF		0.7		V/ns

**Notes:**

- 4) Guaranteed by design.
- 5) Guaranteed by characteristic test.

## TYPICAL CHARACTERISTICS

VDD = 3.3V, temp = 25°C, unless otherwise noted.

**ABZ Jitter**  
PPT = 255, tau = 1ms

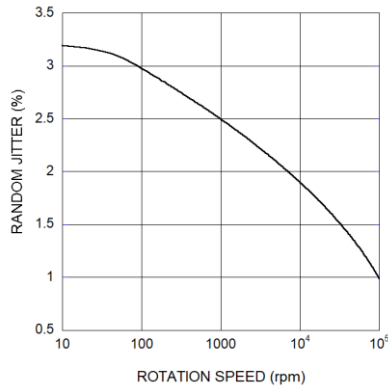

**Current Consumption at VDD = 3.3V**

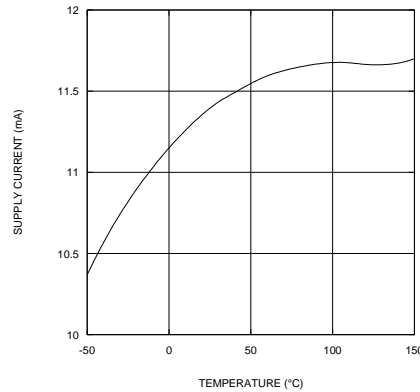

**Filter Transfer Function at  $\tau = 16$  ms**

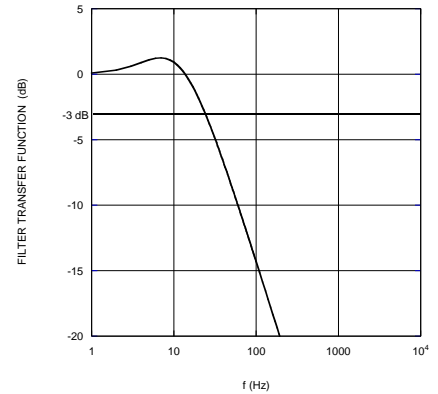

**Error Curves at 50mT**

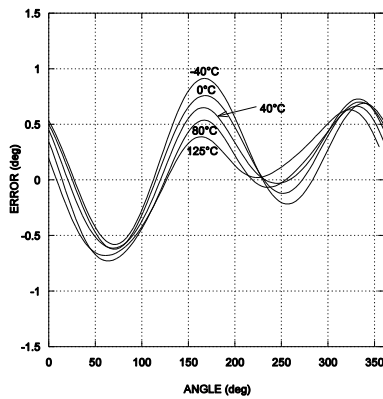

**Nonlinearity (INL and Harmonics)**

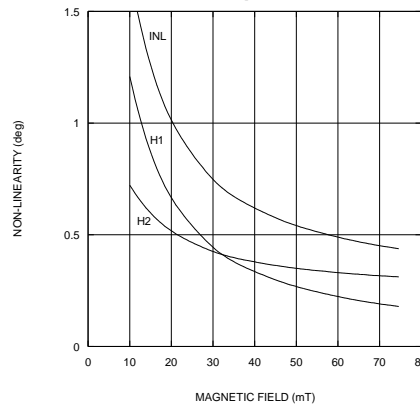

**Effective Resolution ( $3\sigma$ )**

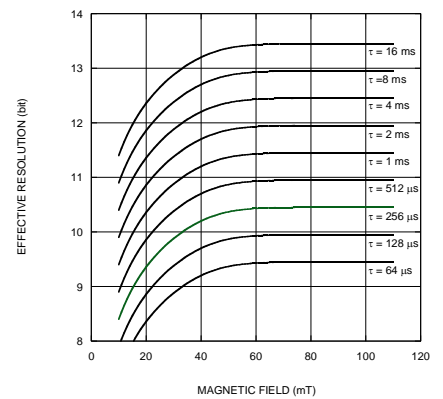

**Noise Spectrum at 50mT and  $\tau = 16$  ms**

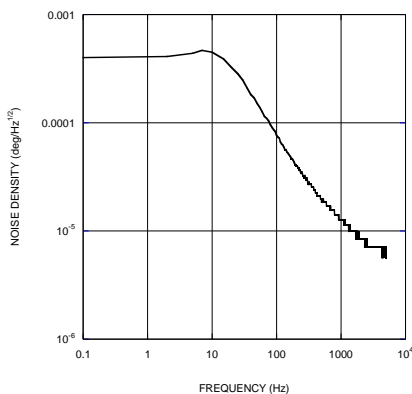

FUNCTIONAL BLOCK DIAGRAM

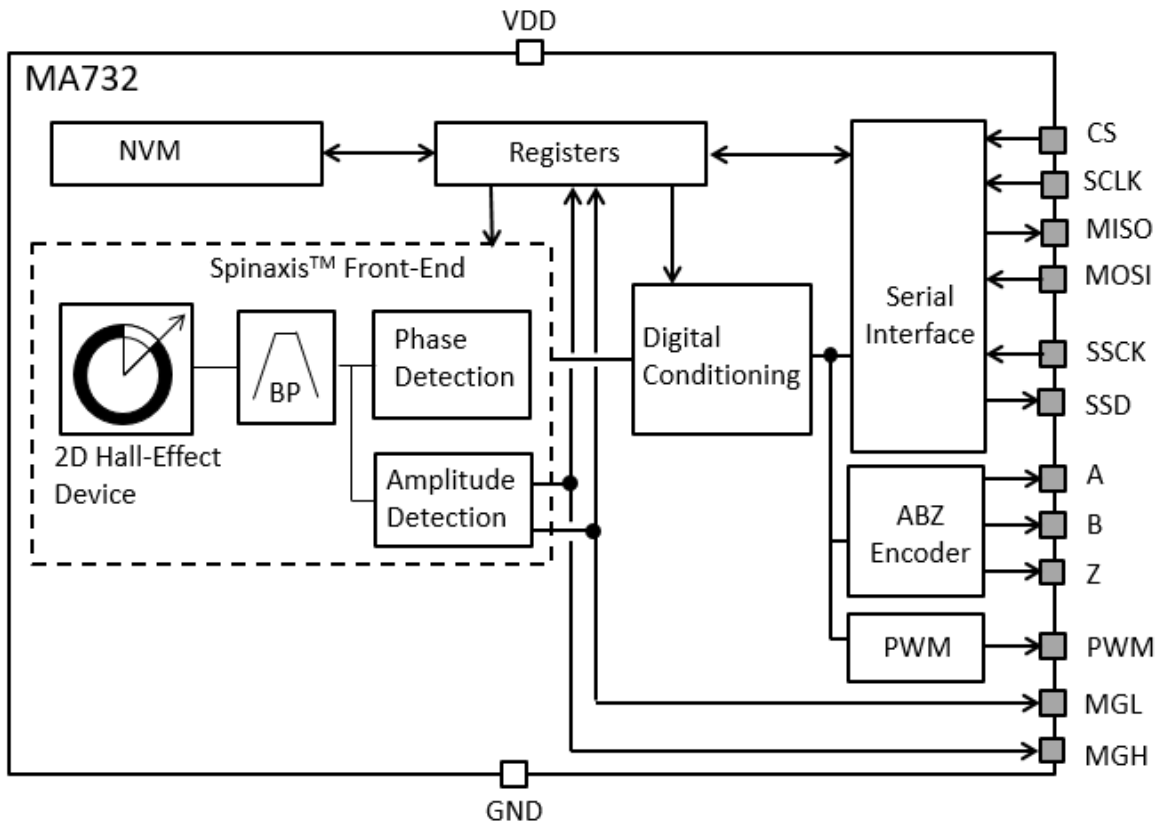

Figure 1: Functional Block Diagram

## OPERATION

### Sensor Front-End

The magnetic field is detected with integrated Hall devices located in the center of the package. The angle is measured using the Spinaxis™ method, which digitizes the direction of the field directly without complex arctangent computations or feedback loop based circuits (interpolators).

The Spinaxis™ method is based on phase detection, and generates a sinusoidal signal with a phase that represents the angle of the magnetic field. The angle is then obtained by a time-to-digital converter, which measures the time between the zero crossing of the sinusoidal signal and the edge of a constant waveform (see Figure 2). The time-to-digital is the output from the front-end to the digital conditioning block.

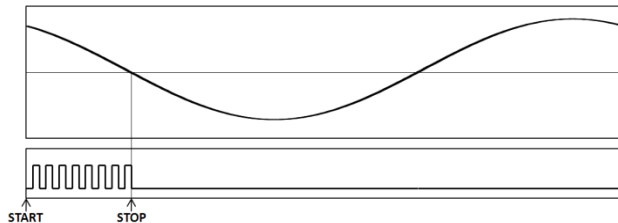

Top – Sine Waveform  
Bottom – Clock of Time-to-Digital Converter  
Figure 2: Phase Detection Method

The output of the front-end delivers a digital number proportional to the angle of the magnetic field at a rate of 1MHz in a straightforward, open-loop manner.

### Digital Filtering

The front-end signal is further treated to achieve the final effective resolution. This treatment does not add any latency in steady conditions. The filter transfer function can be calculated with Equation (1):

$$H(s) = \frac{1 + 2\tau s}{(1 + \tau s)^2} \quad (1)$$

Where  $\tau$  is the filter time constant related to the cutoff frequency by  $\tau = 0.38 / f_{\text{cutoff}}$ . See the General Characteristics section on page 5 for the value of  $f_{\text{cutoff}}$ .

### Sensor Magnet Mounting

The sensitive volume of the MA732 is confined to a region less than 100µm wide, and has multiple integrated Hall devices. This volume is located horizontally and vertically within 50µm of the center of the QFN package. The sensor detects the angle of the magnetic field projected in a plane parallel to the package's upper surface. This means that the only relevant magnetic field is the in-plane component (X and Y components) in the middle point of the package.

By default, if looking at the top of the package, the angle increases when the magnetic field rotates clockwise. Figure 3 shows the zero angle of the unprogrammed sensor, where the cross indicates the sensitive point. Both the rotation direction and the zero angle can be programmed.

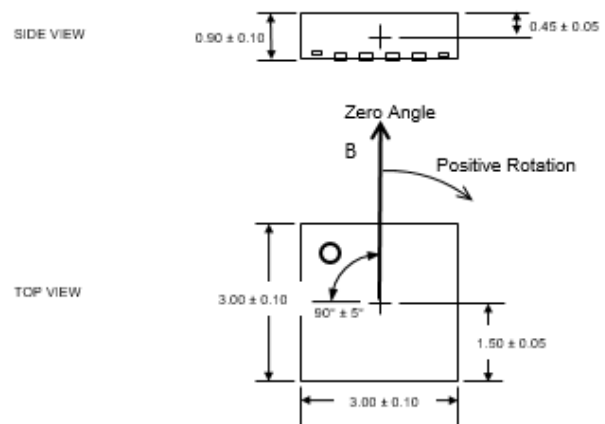
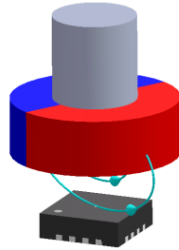

Figure 3: Detection Point and Default Positive Direction

This type of detection provides flexibility for the design of an angular encoder. The sensor only requires the magnetic vector to lie essentially within the sensor plane with a field amplitude of at least 40mT. The MA732 can work with fields smaller than 40mT, but the linearity and resolution performance may deviate from the specifications.

The most straightforward mounting method is to place the MA732 sensor on the rotation axis of a permanent magnet (e.g. a diametrically magnetized cylinder) (see Figure 4). The recommended magnet is a Neodymium alloy (N35) cylinder with dimensions of Ø5x3mm, inserted into an aluminum shaft with a 1.5mm air gap between the magnet and the sensor

(surface of package). For good linearity, the sensor is positioned with a precision of 0.5mm.



**Figure 4: End-of-Shaft Mounting**

If the end-of-shaft position is not available, the sensor can be positioned away from the rotation axis of a cylinder or ring magnet (see Figure 5). In this case, the magnetic field angle is no longer directly proportional to the mechanical angle. The MA732 can be adjusted to compensate for this effect and recover the linear relationship between the mechanical angle and the sensor output. With multiple pole pair magnets, the MA732 indicates multiple rotations for each mechanical turn.

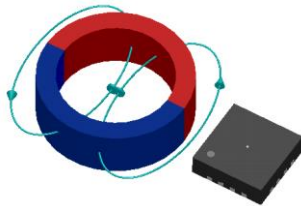

**Figure 5: Side-Shaft Mounting**

### Electrical Mounting and Power Supply Decoupling

It is recommended to place a 1μF decoupling capacitor close to the sensor with a low-impedance path to GND (see Figure 6).

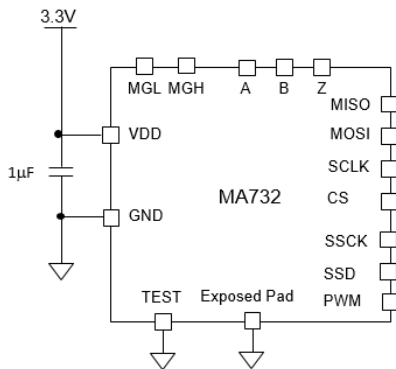

**Figure 6: Connection for Supply Decoupling**

In general, the part works well with or without the exposed pad connected to anything. For optimal conditions (electrically, thermally, and mechanically), it is recommended that the exposed pad be connected to ground.

### Serial Interface

The sensor supports the SPI serial interface for angle reading and register programming. Alternatively, the SSI bus can be used for angle reading (programming through SSI is not supported).

### SPI

SPI is a four-wire, synchronous, serial communication interface. The MA732 supports SPI Mode 3 and Mode 0 (see Table 1 and Table 2). The SPI mode is detected automatically by the sensor, and does not require any action from the user. The maximum clock rate supported on SPI is 25MHz. There is no minimum clock rate. Note that real-life data rates depend on the PCB layout quality and signal trace length. Figure 7 and Table 3 show the SPI timing.

All commands to the MA732 (whether for writing or reading register content) must be transferred through the SPI MOSI pin, and must be 16 bits long. See the SPI Communication section on page 12 for details.

**Table 1: SPI Specification**

	Mode 0	Mode 3
<b>SCLK Idle State</b>	Low	High
<b>Data Capture</b>	On SCLK rising edge	
<b>Data Transmission</b>	On SCLK falling edge	
<b>CS Idle State</b>	High	
<b>Data Order</b>	MSB first	

**Table 2: SPI Standard**

	Mode 0	Mode 3
<b>CPOL</b>	0	1
<b>CPHA</b>	0	1
<b>Data Order (DORD)</b>	0 (MSB first)	

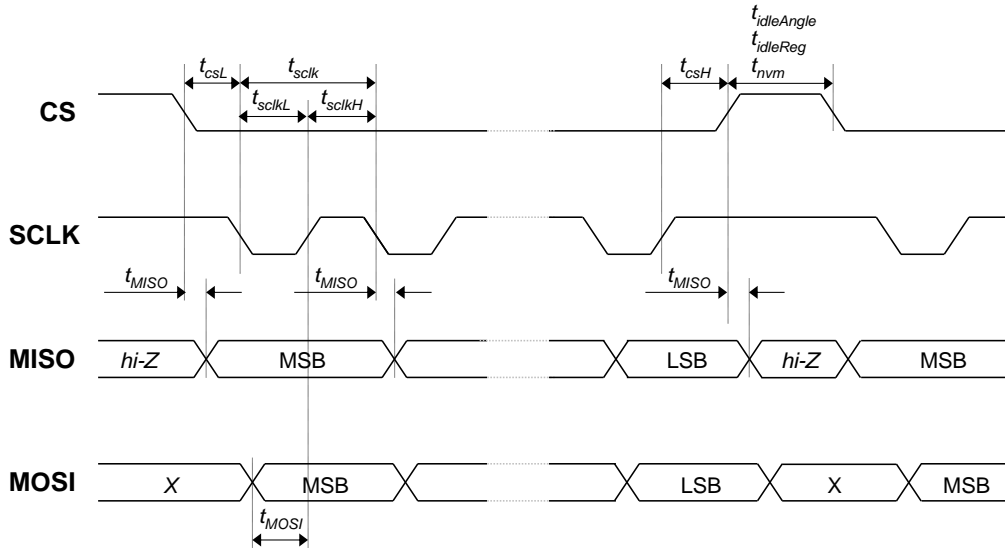
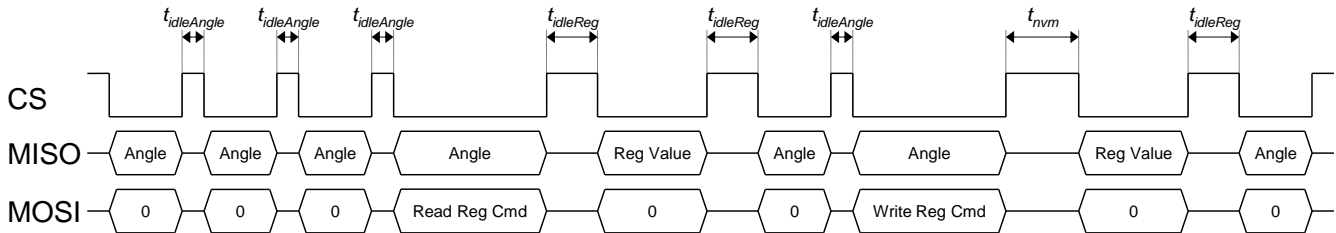
**Figure 7: SPI Timing Diagram**

**Figure 8: Minimum Idle Time**
**Table 3: SPI Timing**

Parameter <sup>(6)</sup>	Description	Min	Max	Unit
$t_{idleAngle}$	Idle time between two subsequent angle transmissions.	150		ns
$t_{idleReg}$	Idle time before and after a register readout.	750		ns
$t_{nvm}$	Idle time between a write command and a register readout (delay necessary for non-volatile memory updates).	20		ms
$t_{csL}$	Time between CS falling edge and SCLK falling edge.	80		ns
$t_{sclk}$	SCLK period.	40		ns
$t_{sclKL}$	Low level of SCLK signal.	20		ns
$t_{sclKH}$	High level of SCLK signal.	20		ns
$t_{csH}$	Time between SCLK rising edge and CS rising edge.	25		ns
$t_{MISO}$	SCLK setting edge to data output valid.		15	ns
$t_{MOSI}$	Data input valid to SCLK reading edge.	15		ns

**Note:**

6) All values are guaranteed by design.

### SPI Communication

The sensor supports three types of SPI operation:

- Read angle
- Read configuration register
- Write configuration register

Each operation has a specific frame structure, described below.

### SPI Read Angle

Every 1µs, new data is transferred into the output buffer. The master device triggers the reading by pulling CS low.

When a trigger event is detected, the data remains in the output buffer until the CS signal is de-asserted (see Table 4).

**Table 4: Sensor Data Timing**

Event	Action
CS falling edge	Start reading and freeze output buffer
CS rising edge	Release of the output buffer

Figure 9 shows the diagram for a full SPI angle reading. Figure 10 shows a partial SPI angle reading. A full angle reading requires 16 clock pulses. The sensor MISO line returns:

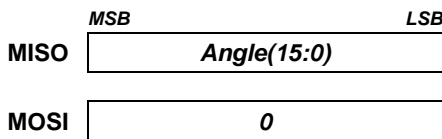

The MagAlpha family has sensors with different features and levels of resolution. See the data output length in the General Characteristics section on page 5 for the number of useful bits delivered at the serial output. If the data length is smaller than 16, the rest of the bits sent are zeros. For example, a data output length of 12 bits means the serial output delivers a 12-bit angle value with 4 bits of zeros padded at the end (MISO state remains zero). If the master sends 16 clock counts, the MA732 replies with:

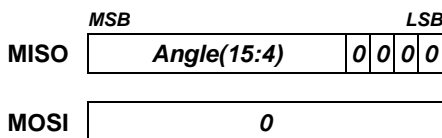

Angle reading can therefore be optimized without any information loss by reducing the number of clock counts. For a 12-bit data output length, only 12 clock counts are required to get the full sensor resolution.

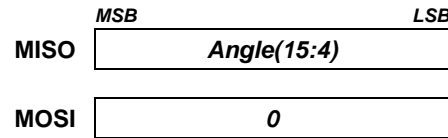

If less resolution is needed, the angle can be read by sending even fewer clock counts (since the MSB is first).

When fast reading, the MA732 continues sending the same data until the data is refreshed. See the refresh rate in the General Characteristics section on page 5.

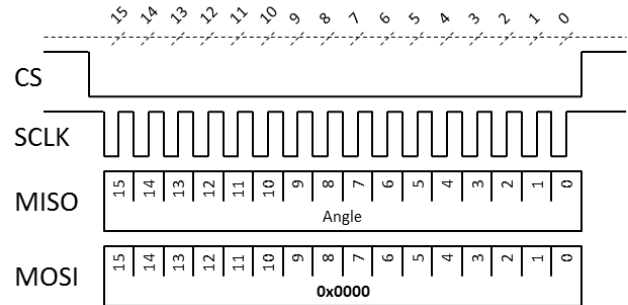

**Figure 9: Diagram of a Full 16-Bit SPI Angle Reading**

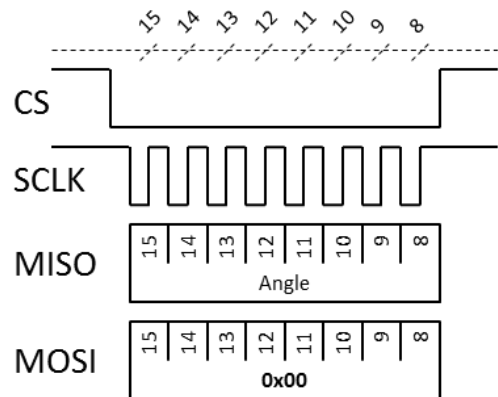
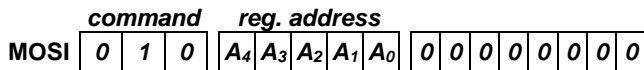
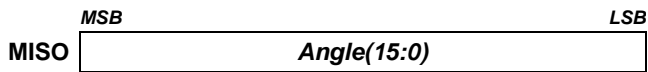

**Figure 10: Diagram of a Partial 8-Bit SPI Angle Reading**

### SPI Read Register

A read register operation is constituted of two 16-bit frames. The first frame sends a read request, which contains the 3-bit read command (010) followed by the 5-bit register address. The last 8 bits of the frame must all be set to zero. The second frame returns the 8-bit register value (MSB byte).

The first 16-bit SPI frame (read request) is:



The second 16-bit SPI frame (response) is:

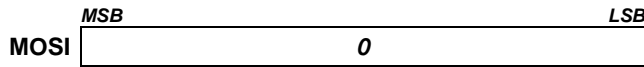
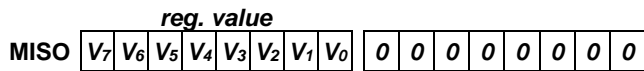
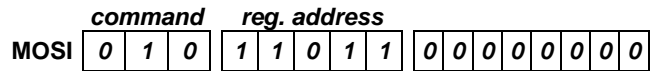
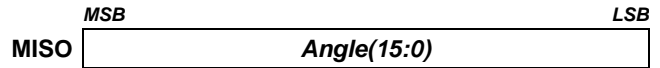

Figure 11 shows a complete transmission overview.

For example, to get the value of the magnetic level high and low flags (MGH and MGL), read register 27 (bit 6, bit 7) by sending the following first frame:



In the second frame, the MA732 replies:

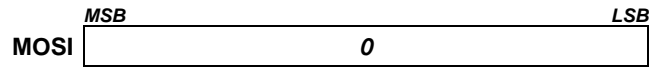
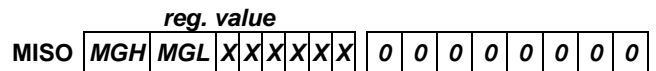
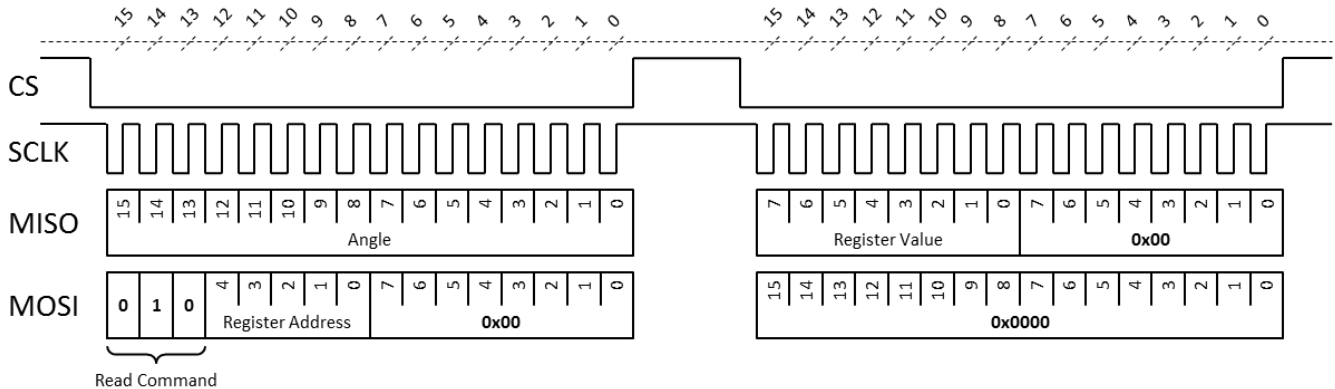
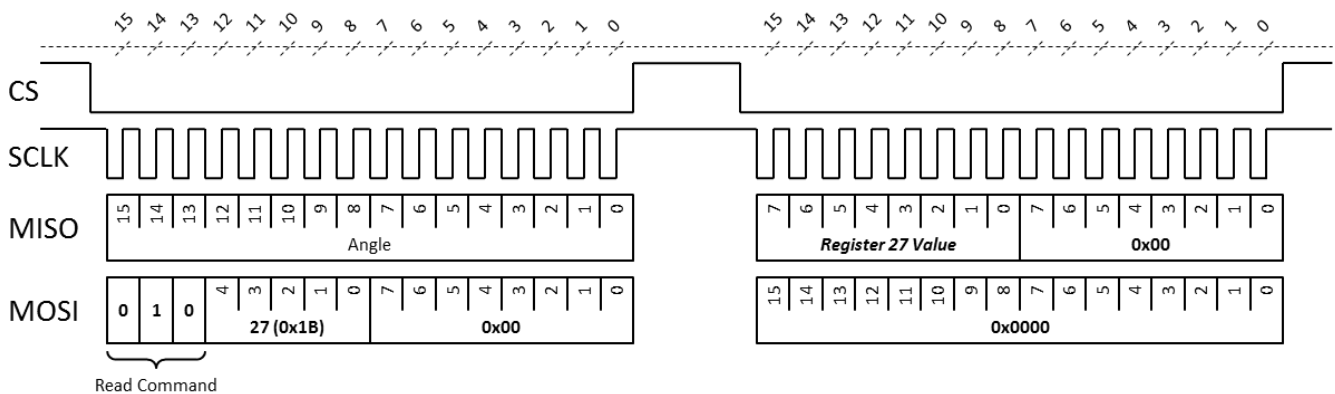

Figure 12 shows a complete example overview.



**Figure 11: Two 16-Bit Frames Read Register Operation**



**Figure 12: Example Read Magnetic Level Flags High and Low (MGH, MGL) on Register 27, Bit 6 to Bit 7**

### SPI Write Register

Table 7 shows the programmable 8-bit registers. Data written to these registers is stored in the on-chip, non-volatile memory and is automatically reloaded at power-on. Table 8 shows the factory default register values.

A write register operation is constituted of two 16-bit frames. The first frame sends a write request, which contains the 3-bit write command (100) followed by the 5-bit register address and the 8-bit value (MSB first). The second frame returns the newly written register value (acknowledge). The on-chip memory is guaranteed to endure 1,000 write cycles at 25°C.

It is critical to wait 20ms between the first and second frame. This is the time taken to write the non-volatile memory. Failure to implement this wait period results in the register's previous value being read. Note that this delay is only required after a write request, and is not necessary for a read register request or read angle.

The first 16-bit SPI frame (write request) is:

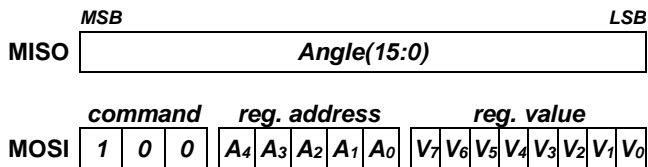

The second 16-bit SPI frame (response) is:

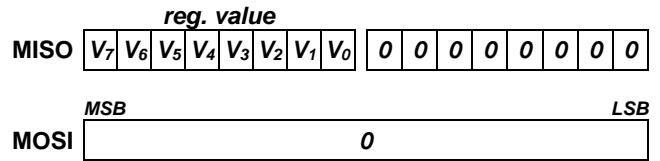

The readback register content can be used to verify the register programming. Figure 13 shows a complete transmission overview.

For example, to set the value of the output rotation direction (RD) to counterclockwise (high), write register 9 by sending the following first frame:

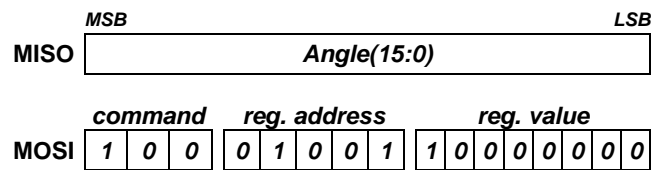

Send the second frame after a 20ms wait time (see Figure 8). If the register is written correctly, the reply is:

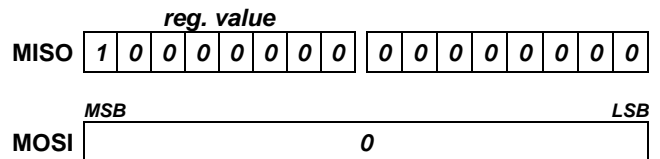
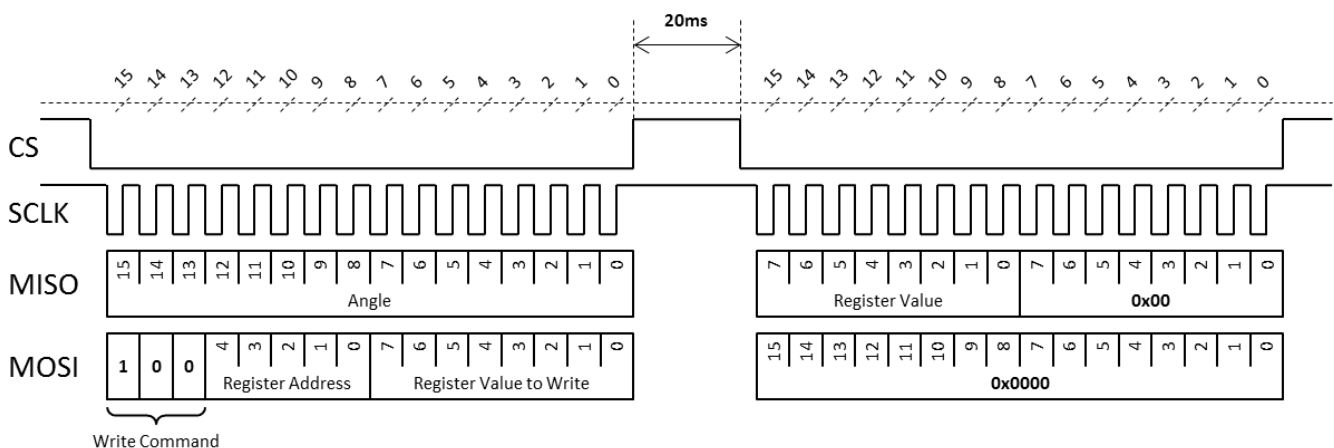
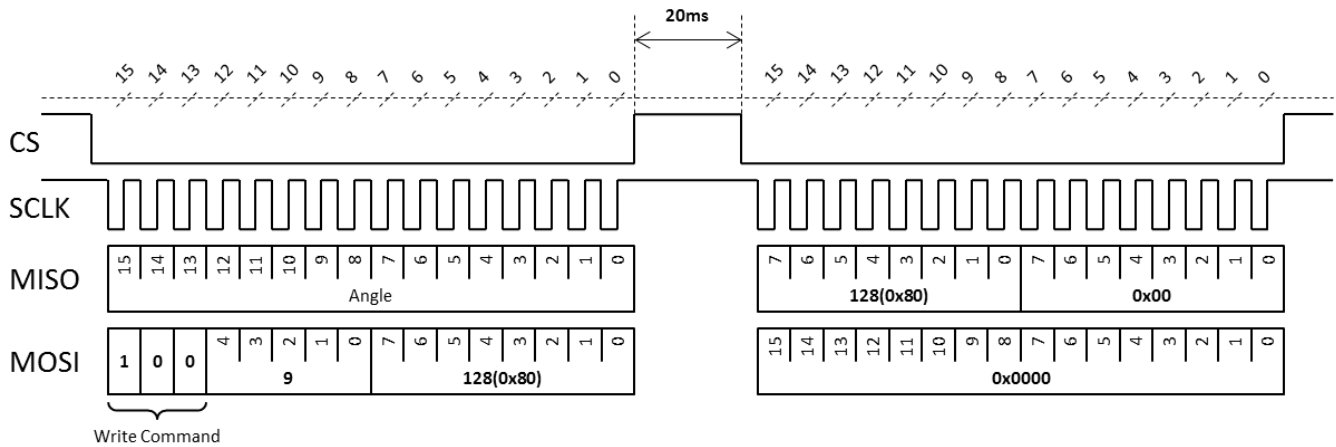

Figure 14 shows a complete example.



**Figure 13: Overview of Two 16-Bit Frames Write Register Operation**



**Figure 14: Example Write Output Rotation Direction (RD) to Counterclockwise (High), on Register 9, Bit 7**

### SSI

SSI is a two-wire, synchronous serial interface for data reading only. The sensor operates as a slave to the external SSI master and only supports angle reading. It is not possible to read or write registers using SSI.

The SSI implemented in this sensor is different from the standard SSI. For this reason it may not work with regular SSI devices.

### SSI Communication

Unlike SPI, the sensor SSI only supports angle reading operation. It is not possible to read or write registers using SSI. Figure 15 and Table 5 show the SSI timing communication.

This sensor uses an SSI with a low SSCK idle state instead of the high SSCK idle state used in the standard protocol. Also this sensor requires a dummy rising edge on the SSCK signal at the beginning of the SSI frame while the standard SSI does not.

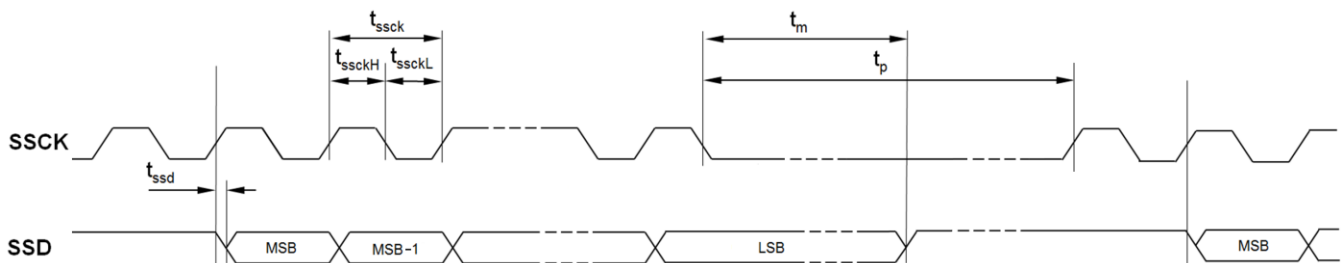

**Figure 15: SSI Timing**

**Table 5: SSI Timing**

Parameter	Description	Min	Max	Unit
$t_{ssd}$			15	ns
$t_{ssck}$	SSCK period.	0.2	16	$\mu$ s
$t_{ssckL}$	Low level of SSCK signal.	0.1	8	$\mu$ s
$t_{ssckH}$	High level of SSCK signal.	0.1	8	$\mu$ s
$t_m$	Transfer timeout (monoflop time).	25		$\mu$ s
$t_p$	Dead time: SSCK high time for next data reading.	40		$\mu$ s

### SSI Read Angle

The bit order of the transmitted data is MSB first and LSB last. Every 1 $\mu$ s, new data is transferred into the output buffer. The master device triggers the reading by driving SSCK high. A full reading requires up to 17 clock counts (see Figure 16).

The first clock is a dummy clock to start the transmission. The data length is up to 16 bits long. See the data output length in the General Characteristics section on page 5 for the number of useful bits delivered at the serial output.

The first data MSB is transmitted on the second clock count. If the data length is less than 16 bits, the 16-bit output word is completed by zeros. Therefore, the reading can also be performed with fewer than 16 clock counts. For example, for a part with a 12-bit data length, it is only necessary to send the first dummy clock to start the transmission plus 12 clocks to read the angle data.

When a trigger event is detected, the data remains in the output buffer until the clock falling edge for the LSB bit 0 and the transfer timeout time have passed (see Table 6).

**Table 6: Sensor Data Timing**

Trigger Event	Release of the Output Buffer
First SSCK pulse rising edge	SSCK falling edge + time out $t_m$ (Fig 15)

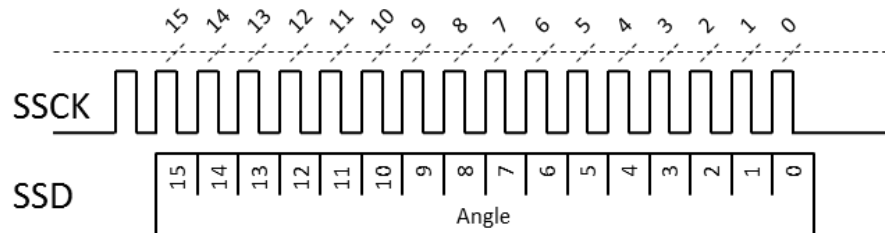

**Figure 16: Diagram of a Full 16-Bit SSI Angle Reading (with First Dummy Clock)**

Figure 17 shows consecutive angle readings in the timing diagram.

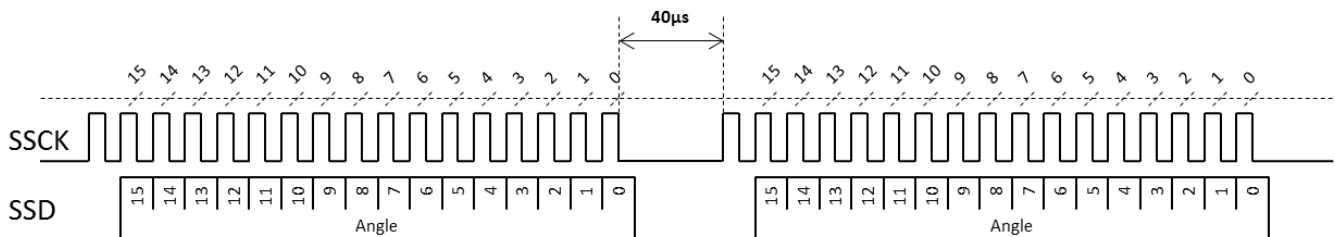

**Figure 17: Diagram of Two Consecutive 16-Bit SSI Angle Reading with the Required Dead Time between the Frames**

**REGISTER MAP**
**Table 7: Register Map**

No.	Hex	Bin	Bit 7 MSB	Bit 6	Bit 5	Bit 4	Bit 3	Bit 2	Bit 1	Bit 0 LSB
0	0x0	00000	Z(7:0)							
1	0x1	00001	Z(15:8)							
2	0x2	00010	BCT(7:0)							
3	0x3	00011	-	-	-	-	-	-	ETY	ETX
4	0x4	00100	PPT(1:0)		ILIP(3:0)			-	-	
5	0x5	00101	PPT(9:2)							
6	0x6	00110	MGLT(2:0)			MGHT(2:0)		-	-	
9	0x9	01001	RD	-	-	-	-	-	-	-
14	0xE	01110	FW(7:0)							
16	0x10	10000	HYS(7:0)							
27	0x1B	11011	MGH	MGL	-	-	-	-	-	-

**Table 8: Factory Default Values**

No.	Hex	Bin	Bit 7 MSB	Bit 6	Bit 5	Bit 4	Bit 3	Bit 2	Bit 1	Bit 0 LSB
0	0x0	00000	0	0	0	0	0	0	0	0
1	0x1	00001	0	0	0	0	0	0	0	0
2	0x2	00010	0	0	0	0	0	0	0	0
3	0x3	00011	0	0	0	0	0	0	0	0
4	0x4	00100	1	1	0	0	0	0	0	0
5	0x5	00101	1	1	1	1	1	1	1	1
6	0x6	00110	0	0	0	1	1	1	0	0
9	0x9	01001	0	0	0	0	0	0	0	0
14	0xE	01110	0	1	1	1	0	1	1	1
16	0x10	10000	1	0	0	1	1	1	0	0

**Table 9: Programming Parameters**

Parameters	Symbol	Number of Bits	Description	See Table
Zero setting	Z	16	Sets the zero position.	10
Bias current trimming	BCT	8	For side-shaft configuration. Reduces the bias current of the X or Y Hall device.	13
Enable trimming X	ETX	1	Biased current trimmed in the X-direction Hall device.	14
Enable trimming Y	ETY	1	Biased current trimmed in the Y-direction Hall device.	14
Pulses per turn	PPT	10	Number of pulses per turn of the ABZ output.	18
Index length / index position	ILIP	4	Parametrization of the ABZ index pulse.	Fig 26
Magnetic field high threshold	MGHT	3	Sets the field strength high threshold.	16
Magnetic field low threshold	MGLT	3	Sets the field strength low threshold.	16
Rotation direction	RD	1	Determines the sensor positive direction.	12
Filter window	FW	8	Size of the digital filter window.	17
Hysteresis	HYS	8	Hysteresis of the ABZ output.	20

## REGISTER SETTINGS

### Zero Setting

The zero position of the MA732 ( $a_0a_0$ ) can be programmed with 16 bits of resolution. The angle streamed out by the part ( $a_{out}$ ) is calculated with Equation (2):

$$a_{out} = a_{raw} - a_0 \quad (2)$$

Where  $a_{raw}$  is the raw angle provided by the MA732 front-end.

The parameter Z(15:0), which is zero by default, is the complementary angle of the zero setting. It can be written in decimals using Equation (3):

$$a_0 = 2^{16} - Z(15:0) \quad (3)$$

Table 10 shows the zero setting parameter.

**Table 10: Zero Setting Parameter**

Z(15:0)	Zero pos. $a_0$ 16-bit (dec)	Zero pos. $a_0$ (deg)
0	65536	360.000
1	65535	359.995
2	65534	359.989
...	...	...
65534	2	0.011
65535	1	0.005

### Example

To set the zero position to 20 degrees, the Z(15:0) parameter must be equal to the complementary angle, and can be calculated with Equation (4):

$$Z(15:0) = 2^{16} - \frac{20\text{deg}}{360\text{deg}} 2^{16} = 61895 \quad (4)$$

In binary, this is written as 1111 0001 1100 0111.

Table 11 shows the content of registers 0 and 1.

**Table 11: Register 0 and 1 Content**

Reg	Bit 7	Bit 6	Bit 5	Bit 4	Bit 3	Bit 2	Bit 1	Bit 0
0	1	1	0	0	0	1	1	1
1	1	1	1	1	0	0	0	1

### Rotation Direction

By default, when looking at the top of the package, the angle increases when the magnetic field rotates clockwise (see Figure 18 and Table 12).

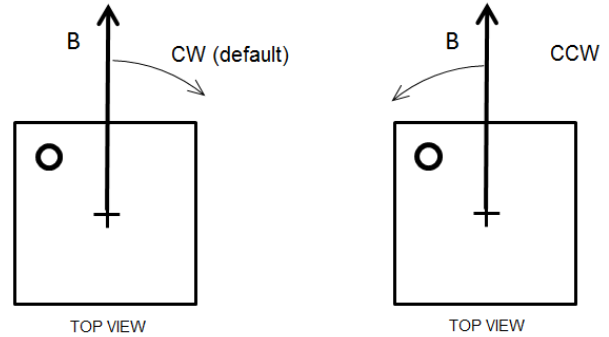

**Figure 18: Positive Rotation Direction of the Magnetic Field**

**Table 12: Rotation Direction Parameter**

RD	Positive Direction
0	Clockwise (CW)
1	Counterclockwise (CCW)

### BCT Settings (Bias Current Trimming)

#### Side Shaft

When the MA732 is mounted on the side of the magnet, the relationship between the field angle and the mechanical angle is no longer directly linear. This effect is related to the fact that the tangential magnetic field is usually smaller than the radial field. The field ratio  $k$  can be determined with Equation (5):

$$k = B_{rad} / B_{tan} \quad (5)$$

Where  $B_{rad}$  and  $B_{tan}$  are the maximum radial and tangential magnetic fields (see Figure 19).

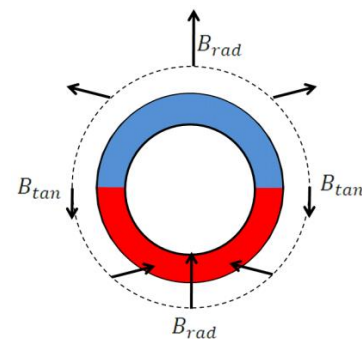

**Figure 19: Side-Shaft Field**

The ratio  $k$  depends on the magnet geometry and the distance to the sensor. Having a  $k$  ratio other than 1 results in the sensor output response not being linear with respect to the mechanical angle. Note that the error curve has the shape of a double sinewave (see Figure 21).  $E$  is the amplitude of this error.

The X-axis or the Y-axis bias current can be reduced in order to recover an equal Hall signal for all angles and therefore suppress the error. The parameters ETX and ETY control the direction in which sensitivity is reduced. The current reduction is set by the parameter bias current trimming BCT(7:0), which is an integer from 0 to 255.

In side-shaft configuration (i.e. the sensor center is located beyond the magnet outer diameter),  $k > 1$ . For optimum compensation, the sensitivity of the radial axis should be reduced by setting the BCT parameter using Equation (6):

$$BCT(7:0) = 258 \left( 1 - \frac{1}{k} \right) \quad (6)$$

Figure 20 shows the optimum BCT value for a particular  $k$  ratio in graph form.

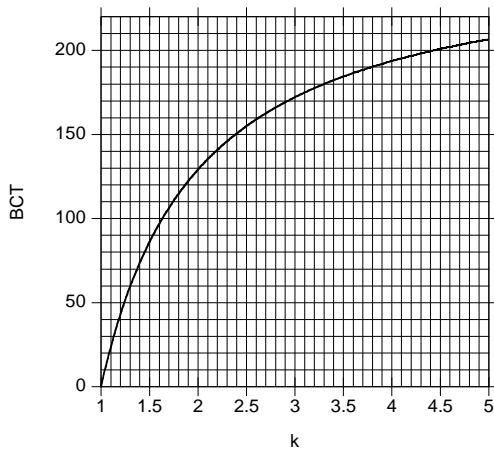

**Figure 20: Relationship between the  $k$  Ratio and the Optimum BCT to Recover Linearity**

Table 13 shows some typical BCT values.

**Table 13: Example of BCT Settings**

E (deg)	Magnet Ratio ( $k$ )	BCT(7:0)
0	1.0	0
11.5	1.5	86
19.5	2.0	129
25.4	2.5	155
30.0	3.0	172
33.7	3.5	184
36.9	4.0	194
39.5	4.5	201
41.8	5.0	207

### Determining $k$

The  $k$  ratio can be deduced from the error curve obtained with the default BCT setting (BCT = 0). To do this, rotate the magnet over one revolution and record the device's output. Then plot the error curve (the output minus the real mechanical position vs. the real mechanical position) and extract two parameters: the maximum error ( $E$ ) and the position of this maximum with respect to a zero crossing  $a_m$  (see Figure 21).  $k$  can be calculated with Equation (7):

$$k = \frac{\tan(E + a_m)}{\tan(a_m)} \quad (7)$$

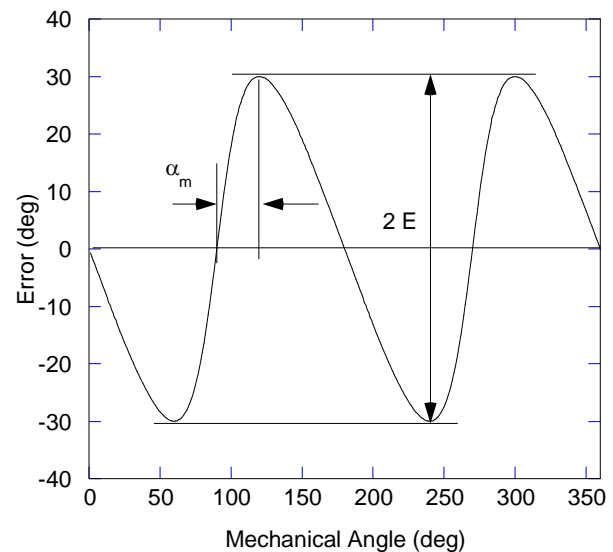

**Figure 21: Error Curve in Side-Shaft Configuration with BCT = 0**

Table 13 shows some examples. Alternatively, the  $k$  parameter can be obtained from a graph (see Figure 22).

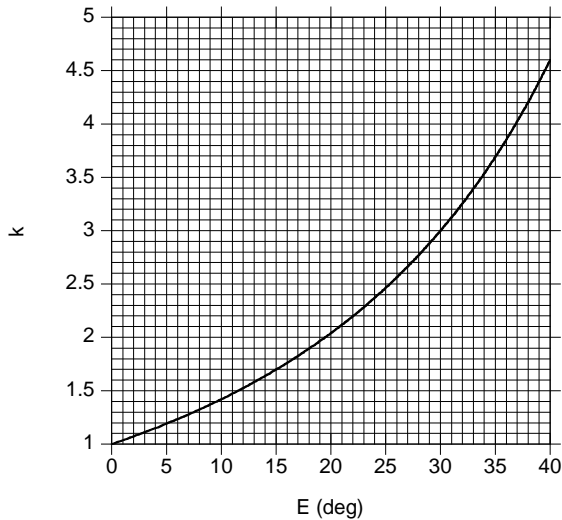

**Figure 22: Relationship between the Error Measured with BCT = 0 and the Magnet Ratio  $k$**

### Sensor Orientation

The dot marked on the package shows whether the radial field is aligned with the sensor coordinate X or Y (see Figure 23).

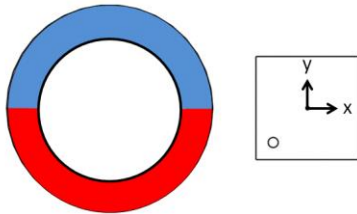

**Figure 23: Package Top View with X and Y Axes**

Determine which axis needs to be reduced (see the qualitative field distribution around a ring in Figure 19). For instance, Figure 23 shows an arrangement in which the field along the sensor Y direction is tangential and weaker. The X-axis should be reduced (ETX = 1 and ETY = 0). Note that if both ETX and ETY are set to 1, the current bias is reduced in both directions the same way (i.e. without side-shaft correction) (see Table 14).

**Table 14: Trimming Direction Parameters**

ETX	Enable Trimming of the X-Axis
0	Disabled
1	Enabled
ETY	Enable Trimming of the Y-Axis
0	Disabled
1	Enabled

### Magnetic Field Thresholds

The magnetic flags (MGL and MGH) indicate that the magnetic field at the sensor position is out of the range defined by the lower (MGLT) and upper magnetic field thresholds (MGHT) (see Figure 24).

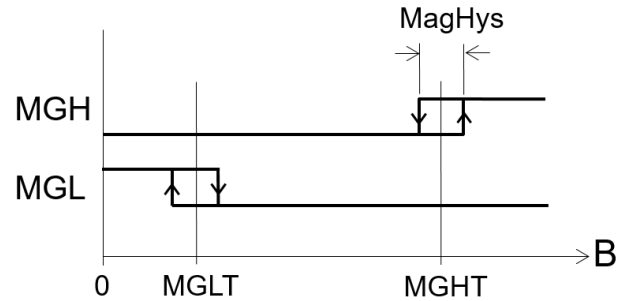

**Figure 24: MGH and MGL Signals as a Function of the Field Strength**

MagHys, the typical hysteresis on the signals MGH and MGL, is 6mT. The MGLT and MGHT thresholds are coded on 3 bits and stored in register 6 (see Table 15).

**Table 15: Register 6**

Register 6							
Bit 7	Bit 6	Bit 5	Bit 4	Bit 3	Bit 2	Bit 1	Bit 0
MGLT			MGHT			-	-

The 3-bit values of MGLT and MGHT correspond to the magnetic field (see Table 16).

**Table 16: MGLT and MGHT Binary to mT Relationship**

MGLT or MGHT <sup>(8)</sup>	Field Threshold in mT <sup>(7)</sup>	
	From Low to High Magnetic Field	From High to Low Magnetic Field
000	26	20
001	41	35
010	56	50
011	70	64
100	84	78
101	98	92
110	112	106
111	126	120

**Notes:**

- 7) Valid for VDD = 3.3V. If different, then the field threshold is scaled by the factor VDD/3.3V.
- 8) MGLT can have a larger value than MGHT.

The alarm flags MGL and MGH can be read in register 27 (bit 6 and 7), and their logic state is also given at digital output pins 11 and 16.

To read the MGL and MGH flags via the SPI, send the 8-bit write command to register 27:

command	reg. address	MSB	value	LSB
0 1 0	1 1 0 1 1	0 0 0 0 0 0 0 0		

The MA732 answers with the register 27 content in the next transmission:

Register 27 [7:0]							
MGH	MGL	x	x	MG1L	MG2L	x	x

The logic state of the MGL and MGH flags has no effect on the angle output.

### MGL Application Note

Pulses with a duration of about 1.3µs to 1.5µs appear randomly in the MGL signal. They appear on both the pin and register values (Register 27, bit 6).

These pulses appear around angle values of 44, 138, 224, and 318 degrees (sensor output) or in an interval of ±1.5 degrees around these values. These pulses have an amplitude of 3.3V (VDD). The minimum interval between two pulses is 100µs.

### MGL Workarounds

1. Invert the MGH signal to replace MGL. The MGL and MGH magnetic thresholds only differ by a small hysteresis (see Table 16 on page 21). An inverted MGH signal can be used to replace the MGL output in the application.
2. Read the MGL signal level twice. Using two readings, which must be between 2µs and 100µs apart, allows the user to distinguish erroneous from real transitions. Table 17 shows examples of different cases.
3. Read register 27 with the SPI and compute a corrected MGL value using MG1L and MG2L. The corrected MGL signal = not (MG1L OR MG2L). This means that the corrected MGL must be set to 1 only when both MG1L and MG2L are equal to 0. See the C implementation below:

```
correctedMGL = !(MG1L | MG2L)
```

**Table 17: MGL Multiple Reading Workaround**

	MGL First Reading	MGL Second Reading (e.g. 20µs After the First Reading)	True MGL Value
Case 1	0	Second reading is not needed	0
Case 2	1	1	1
Case 3	1	0	0

### Filter Window

The filter window affects the effective resolution (defined as the ±3σ noise interval) and the output bandwidth, which is characterized by the cutoff frequency. Table 18 shows the resulting resolution and bandwidth for each window.

**Table 18: Filter Window**

FW(7:0)	Time Const. τ (µs)	Effective Resolution at 45mT (bit)	f <sub>cutoff</sub> (Hz)	Power-Up Time (ms)
51	64	9.5	6000	0.5
68	128	10	3000	1.1
85	256	10.5	1500	2.5
102	512	11	740	5.5
119 (default)	1024	11.5	370	12
136	2048	12	185	26
153	4096	12.5	93	57
170	8192	13	46	123
187	16384	13.5	23	264

The time constant τ is the parameter entering in the transfer function (1). This allows the user to accurately model the system, and in particular analyze the stability of a control loop.

### ABZ Incremental Encoder Output

The MA732 ABZ output emulates a 12-bit incremental encoder (such as an optical encoder) providing logic pulses in quadrature (see Figure 25). Compared to signal A, signal B is shifted by a quarter of the pulse period. Over one revolution, signal A pulses n times, where n is programmable from 1 to 1024 pulses per revolution. The number of pulses per channel per revolution is programmed by setting the parameter PPT, which consists of 8 bits split between registers 0x4 and 0x5 (see Table 7). The factory default value is 1023. Table 19 on page 23 describes how to program PPT(9:0) to set the required resolution.

**Table 19: PPT**

PPT(9:0)	Pulses per Revolution	Edges per Revolution	
000000000	1	4	MIN
000000001	2	8	
000000010	3	12	
000000011	4	16	
...	...	...	...
1111111100	1021	4084	
1111111101	1022	4088	
1111111110	1023	4092	
1111111111	1024	4096	MAX

For example, to set 120 pulses per revolution (i.e. 480 edges), set PPT to  $120 - 1 = 119$  (binary: 0001110111). Registers 4 and 5 must be set as shown in Table 20.

**Table 20: Example PPT Setting for 120 Pulses**

	B7	B6	B5	B4	B3	B2	B1	B0
<b>R4</b>	1	1	0	0	0	0	0	0
<b>R5</b>	0	0	0	1	1	1	0	1

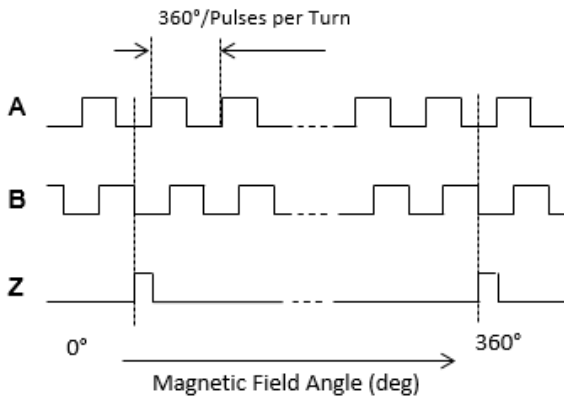
**Figure 25: Timing of the ABZ Output**

Signal Z (zero or index) raises only once per turn, at the zero-angle position.

The position and length of the Z pulse is programmable via bits ILIP[3:0] in register 0x4 (see Figure 26).

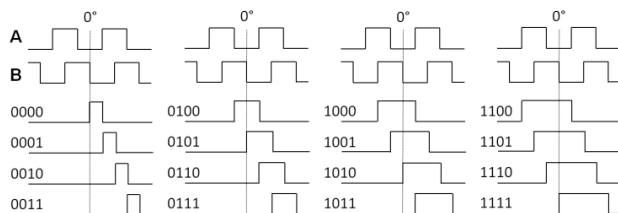
**Figure 26: ILIP Parameter Effect on Index Shape**

By default, the ILIP parameter is 0000. The index rising edge is aligned with the channel B falling edge. The index length is half the A or B pulse length.

### ABZ Hysteresis

The hysteresis is set by the parameter HYS (see Table 21). To avoid spurious transitions (see Figure 27), it is recommended that the hysteresis be 12 times larger than the output rms noise ( $1\sigma$ ). Table 22 shows indications of the  $1\sigma$  noise.

**Table 21: HYS**

HYS(7:0)	Hysteresis (deg)
200	0.08
188	0.14
148	0.18
152	0.36
156 (default)	0.52
116	0.70
120	1.4
124	2.1
84	2.8

**Table 22: RMS Noise**

FW(7:0)	Effective Resolution at 45mT (bit)	$1\sigma$ Noise (deg)
51	9.5	0.08
68	10	0.06
85	10.5	0.04
102	11	0.03
119 (default)	11.5	0.02
136	12	0.015
153	12.5	0.01
170	13	0.007
187	13.5	0.005

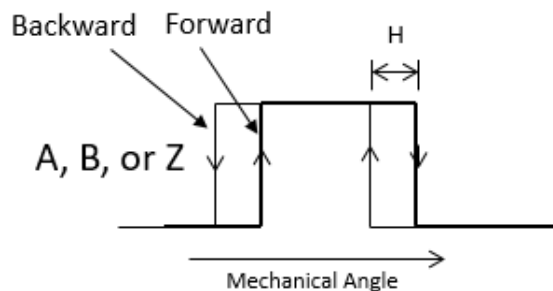
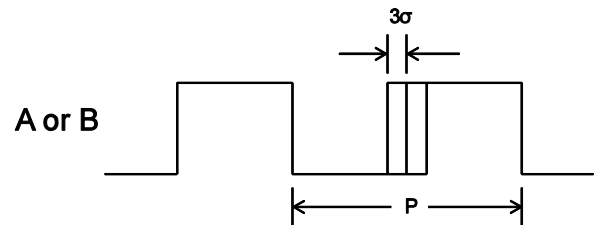

**Figure 27: Hysteresis of the Incremental Output**

### ABZ Jitter

The ABZ state is updated at a frequency of 16MHz, enabling accurate operation up to a very high rpm (above  $10^5$ rpm).

The jitter characterizes how far a particular ABZ edge can occur at an angular position different from the ideal position (see Figure 28).



**Figure 28: ABZ Jitter**

The measurable jitter is composed of a systematic jitter (i.e. always the same deviation at a given angle, as shown in the General Characteristics section) and a random jitter.

The random jitter reflects the sensor noise. Therefore, the edge distribution is the same as the SPI output noise.

In fact, the random jitter is a function of the rotation speed. At a lower speed, the random jitter is smaller than the sensor noise.

This is a consequence of the fact that the probability of measuring an edge at a certain distance from the ideal position depends on the number of ABZ updates at this position.

### PWM Absolute Output

This output provides a logic signal with a duty cycle proportional to the angle of the magnetic field. The PWM frequency is indicated in the General Characteristics section on page 5. The duty cycle is bounded by a minimum value ( $1/514$  of the period) and a maximum value ( $513/514$  of the period), so the duty cycle varies from  $1/514$  to  $513/514$  with a resolution of 14 bits (see Figure 29).

The angle can be retrieved by measuring the on time. Since the absolute PWM frequency can vary from chip to chip or with the temperature, accurate angle detection requires the measurement of the duty cycle (i.e. the measurement of both the on time ( $t_{on}$ ) and the off time ( $t_{off}$ )). The angle can be calculated with Equation (8):

$$angle (in deg) = \frac{360}{512} \left( 514 \frac{t_{ON}}{t_{ON} + t_{OFF}} - 1 \right) \quad (8)$$

Figure 29 shows one period of the PWM signal. The period (T) is  $1/f_{PWM}$ , where  $f_{PWM}$  is the PWM frequency indicated in the General Characteristics section.

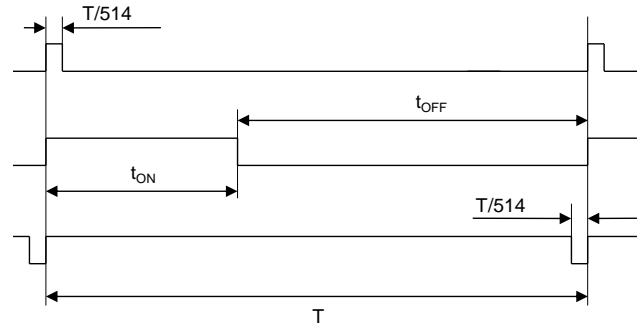

**Figure 29: PWM Output Timing Top Signal: 0° Bottom Signal: Full Scale (i.e. 360° (1 - 1 / 16384))**

## TYPICAL APPLICATION CIRCUITS

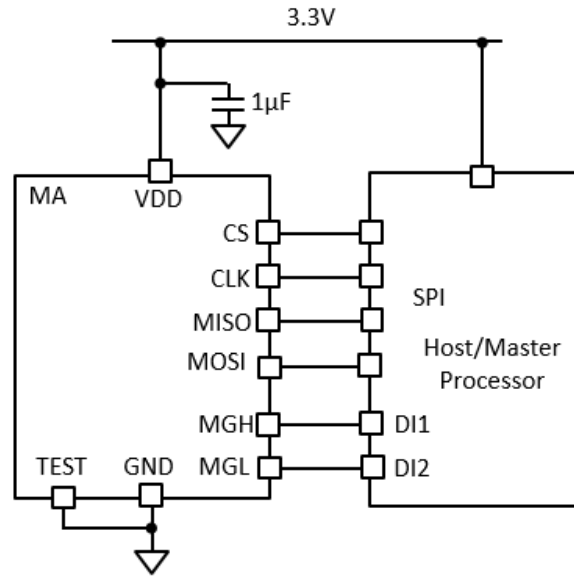

Figure 30: Typical Configurations Using SPI Interface and MGH/MGL Signals

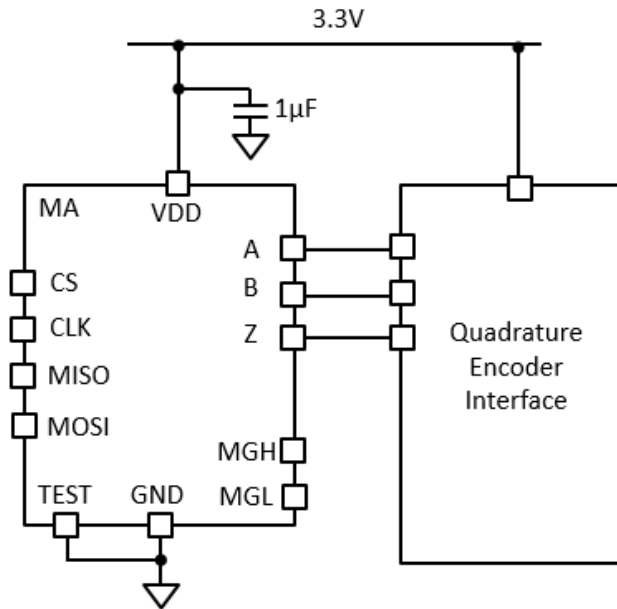
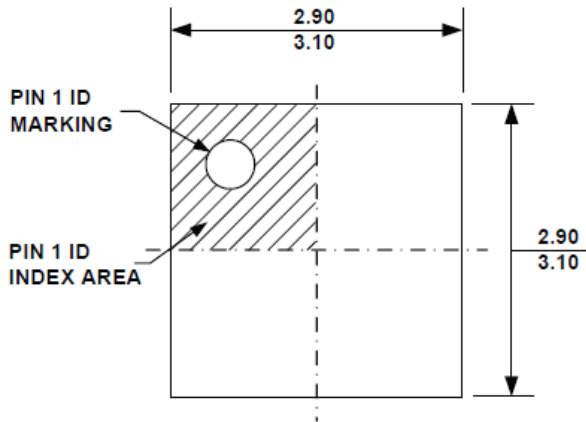

Figure 31: Typical Configuration Using ABZ Interface

**PACKAGE INFORMATION**

**QFN-16 (3mmx3mm)**



**TOP VIEW**

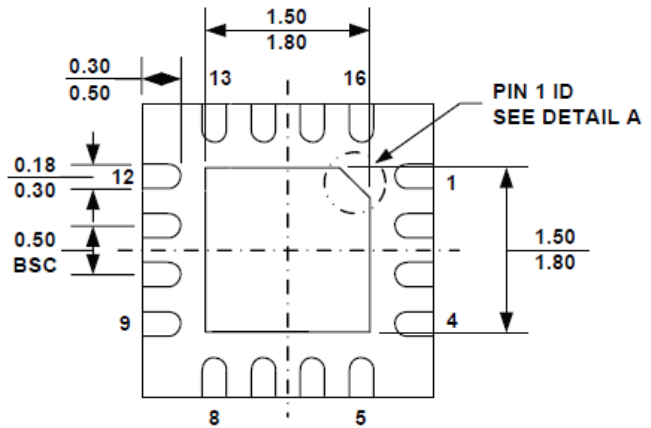

**BOTTOM VIEW**

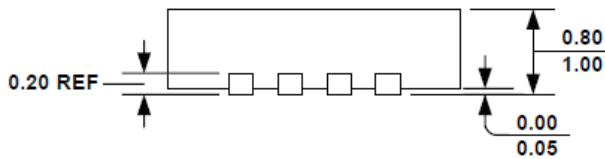

**SIDE VIEW**

**PIN 1 ID OPTION A**  
0.30x45° TYP.

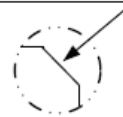

**PIN 1 ID OPTION B**  
R0.20 TYP.

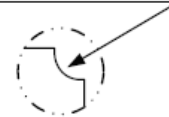

**DETAIL A**

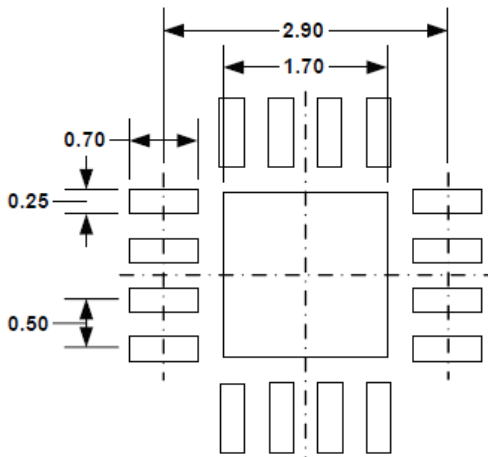

**RECOMMENDED LAND PATTERN**

**NOTE:**

- 1) ALL DIMENSIONS ARE IN MILLIMETERS.
- 2) EXPOSED PADDLE SIZE DOES NOT INCLUDE MOLD FLASH.
- 3) LEAD COPLANARITY SHALL BE 0.10 MILLIMETER MAX.
- 4) DRAWING CONFORMS TO JEDEC MO-220, VARIATION VEED-4
- 5) DRAWING IS NOT TO SCALE.

## APPENDIX A: DEFINITIONS

<b>Effective Resolution (3σ noise level)</b>	Smallest angle increment distinguishable from the noise. The resolution is measured by computing three times σ (the standard deviation in degrees) taken over 1,000 data points at a constant position. The resolution in bits is obtained with $\log_2(360 / 6\sigma)$ .
<b>Refresh Rate</b>	Rate at which new data points are stored in the output buffer.
<b>ABZ Update Rate</b>	Rate at which a new ABZ state is computed. The inverse of this rate is the minimum time between two ABZ edges.
<b>Latency</b>	Time elapsed between the instant when the data is ready to be read and the instant at which the shaft passes that position. The lag in degrees is $lag = latency \cdot v$ , where $v$ is the angular velocity in deg/s.
<b>Power-Up Time</b>	Time until the sensor delivers valid data, starting at power-up.
<b>Integral Nonlinearity (INL)</b>	Maximum deviation between the average sensor output (at a fixed position) and the true mechanical angle (see Figure A1).

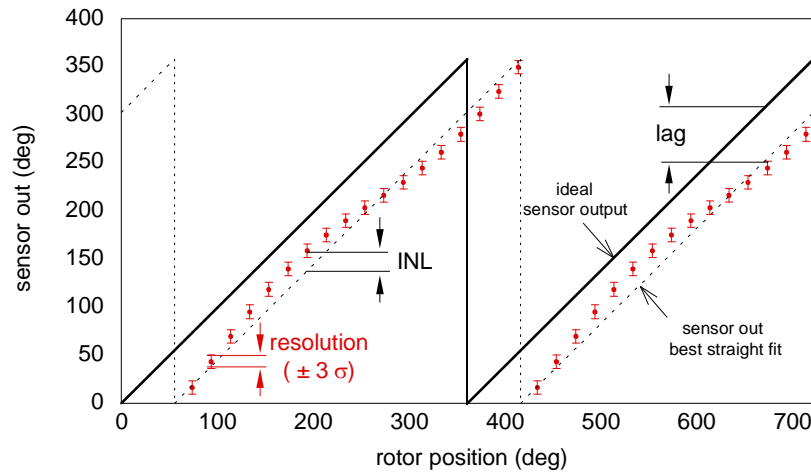

**Figure A1: Resolution, INL, Lag**

INL can be obtained from the error curve  $err(a) = out(a) - a$ , where  $out(a)$  is the average over 1000 sensor output, and  $a$  is the mechanical angle indicated by a high-precision encoder ( $<0.001$  deg). INL is then calculated with Equation (A1):

$$INL = \frac{\max(err(a)) - \min(err(a))}{2} \quad (A1)$$

**Drift** Angle variation rate when one parameter is changed (e.g. temperature, VDD) and all the others, including the shaft angle, are kept constant.

## APPENDIX B: SPI COMMUNICATION CHEATSHEET

### Read Angle

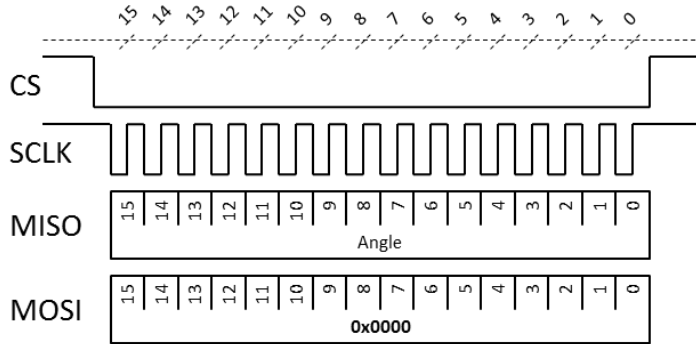

### Read Register

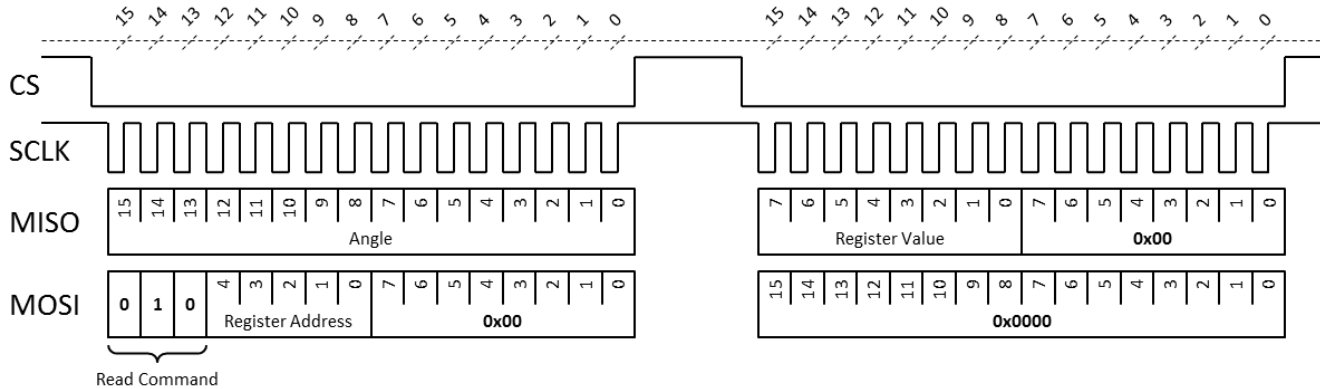

### Write Register

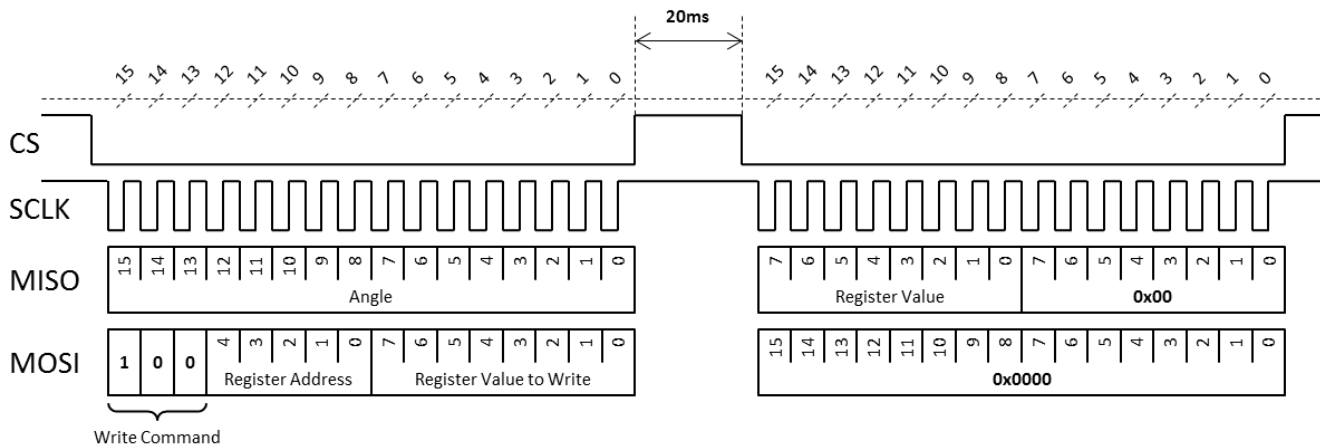

**REVISION HISTORY**

Revision #	Revision Date	Description	Pages Updated
1.0	4/23/2019	Initial Release	-
1.1	8/8/2022	Updated legal notice.	1
		Updated orderable suffix from “-Z” to “-Z”.	2
		Update ABZ Jitter plot.	7
		Updated Figure 24.	21
		Added MGL application details, MGL Workarounds section, and Table 15.	22
		Minor formatting updates.	All

**Notice:** The information in this document is subject to change without notice. Users should warrant and guarantee that third-party Intellectual Property rights are not infringed upon when integrating MPS products into any application. MPS will not assume any legal responsibility for any said applications.