

MS-156C Series

1.35mm Height, Coaxial Switch for Ultra Small Size Inspection



Coax Switch



Compact



RF

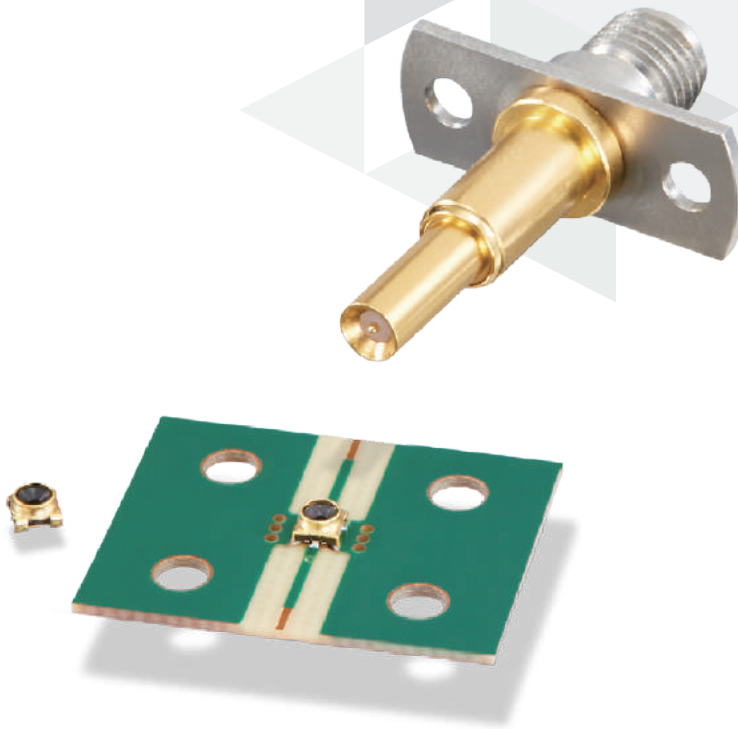

Aug. 1.2024 Copyright 2024 HIROSE ELECTRIC CO., LTD. All Rights Reserved.



Product Page
<https://www.hirose.com/en/product/series/MS-156C>

Jul. 2023

Overview

MS-156C series is ultra small coaxial switch developed for inspection of microwave circuits used for portable terminals circuits and high frequency circuits.

It supports high-density substrate mounting by small size equipment, and supports over a wide frequency range up to 11GHz. Also, you can easily perform circuit tests while in small size.

In the unplugged state, common contact and antenna contact are connected to form circuit.

By mating the plug, the antenna contact switches to the plug side circuit.

Some conventional MS-156HF plugs can be used for the plug connector.

Features

1. Low Insertion Loss

Unmated State

0.15dB Max. (0 to 2.5GHz)

0.2dB Max. (2.5GHz to 6.0GHz)

0.4dB Max. (6.0GHz to 11.0GHz)

2. Low Profile, and Space-Saving

Height : 1.35mm (Nominal)

Size : 2.3mm×2.3mm (Nominal)

Weight : 0.014g

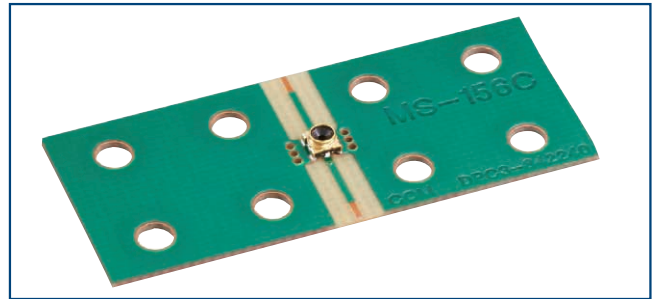

Space-Saving The Substrate Mounting Area

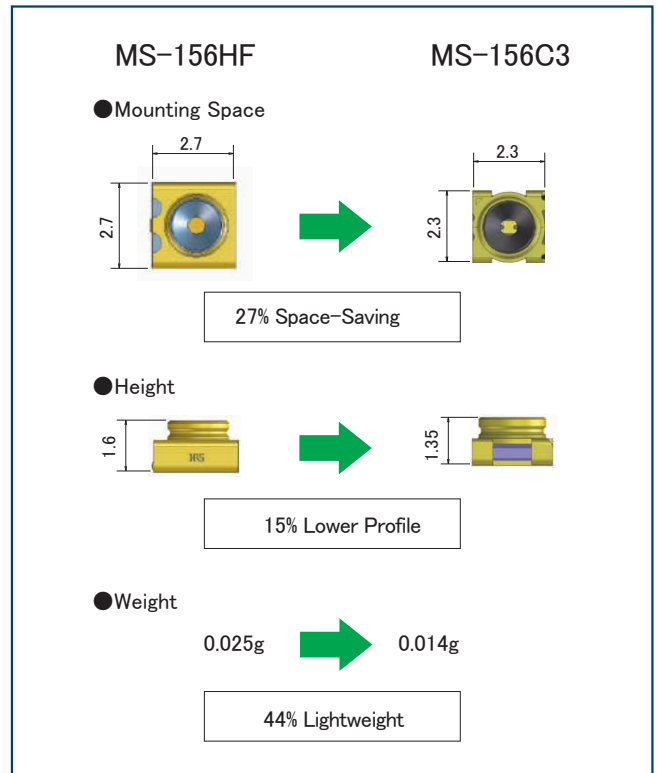

Comparison with Our Conventional Item MS-156HF

3. Performs Over a Wide Frequency Range

Applicable frequencies range over a wide band, from 0 to 11GHz.

4. Corresponding to Automatic Mounting

It supports pick & place mounting with embossed tape.

5. Halogen-free, RoHS2 Compliant

The receptacle and plug do not contain chlorine or bromine above the standard value.

*As defined by IEC 61249-2-21

Br : 900ppm Max., Cl : 900ppm Max., Br+Cl : 1500ppm Max.

Product Specifications

	Unmated	Mated (MS-156-HRMJ-3A)
Operating Temperature	-40°C to +85°C	-40°C to +85°C
Rated Power	2W	2W
Frequency Range	0 to 11.0GHz	0 to 8.0GHz
V.S.W.R.	1.2 or less (0 to 2.5GHz) 1.3 or less (2.5GHz to 6.0GHz) 1.5 or less (6.0GHz to 11.0GHz)	1.4 or less (0 to 3.0GHz) 1.8 or less (3.0GHz to 8.0GHz)
Insertion Loss	0.15dB or less (0 to 2.5GHz) 0.20dB or less (2.5GHz to 6.0GHz) 0.40dB or less (6.0GHz to 11.0GHz)	0.5dB or less (0 to 3.0GHz) 0.8dB or less (3.0GHz to 6.0GHz) 0.9dB or less (6.0GHz to 8.0GHz)
Reverse Loss	20dB (0 to 3.0GHz) 15dB (3.0GHz to 6.0GHz) 12dB (6.0GHz to 11.0GHz)	

Item	Standards	Condition
Contact Resistance	Center 100m Ω Max. External 100m Ω Max.	Measured at 100mA Max.
Insulation Resistance	1,000M Ω Min.	Measured at 100V DC
Withstanding Voltage	No insulation breakdown	100V AC for 1 min.
Vibration Resistance	No electrical discontinuity of 1 μs or more	Frequency 10 to 55Hz, Half amplitude 0.75mm 3 Axial direction 1 oct/min., 10 cycles each, Total 30 cycles
Shock Resistance	No electrical discontinuity of 1 μs or more	Acceleration 490 m/s ² 3 directions at half-sine wave 3 times each, for a Total of 18 times
Temperature Cycle	Contact Resistance: 100m Ω Max. Insulation Resistance: 10M Ω Min.	Temperature: -55 to +5 to +35 → +85 → +5 to +35°C Time: 30 → within 5 min. → 30 → within 5 min. 50 cycles
Heat Resistance	Contact Resistance: 100m Ω Max. Insulation Resistance: 10M Ω Min.	96 hours at temperature of +85°C
Cold Resistance	Contact Resistance: 100m Ω Max. Insulation Resistance: 10M Ω Min.	96 hours at temperature of -55°C
Humidity Resistance	Contact Resistance: 100m Ω Max. Insulation Resistance: 10M Ω Min.	Temperature +40 ± 2°C, humidity 90 to 95%, after 96 hours
Mating Durability	Contact Resistance: 100m Ω Max.	100 times

Note : Information contained in this catalog represents general requirements for this Series.
Contact us for the drawings and specifications for a specific part number shown.

Materials / Finish

Component	Material	Finish	UL Standard
Shell	Phosphorous Bronze	Gold Plating	-
Insulator	6T Nylon	-	UL94HB
Common Contact	Copper Alloy	Partial Gold Plating	-
Antenna Contact	Phosphorous Bronze	Partial Gold Plating	-

Frequency Characteristics (TYPICAL)

● NORMALLY CLOSED (Unmated)

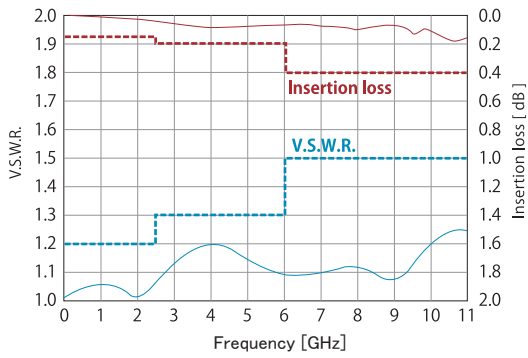

● NORMALLY OPEN (Mated)

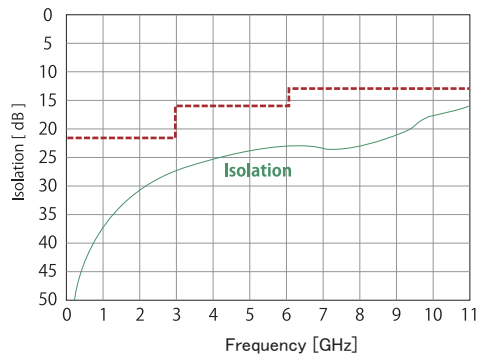
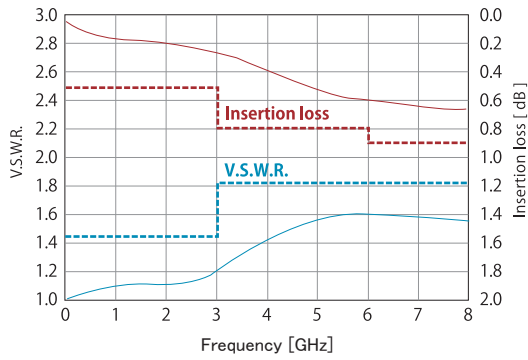

Receptacle

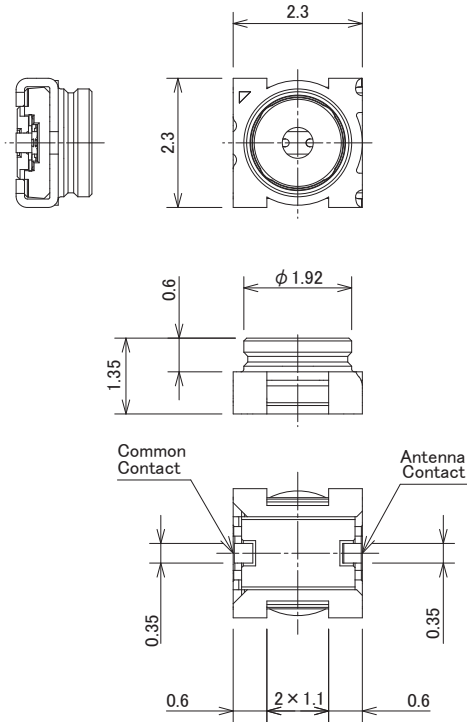

Part No.	HRS No.	Purchase Unit
MS-156C3	CL0358-0340-0-00	10,000pcs per reel
MS-156C3(20)	CL0358-0340-0-20	2,000pcs per reel

■ Circuit Diagram

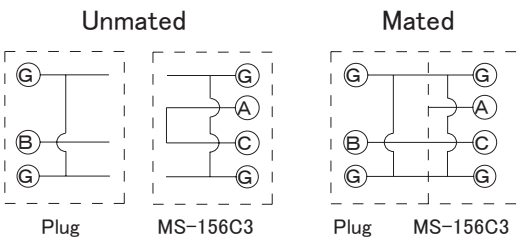

■ PCB Mounting Pattern Dimensions

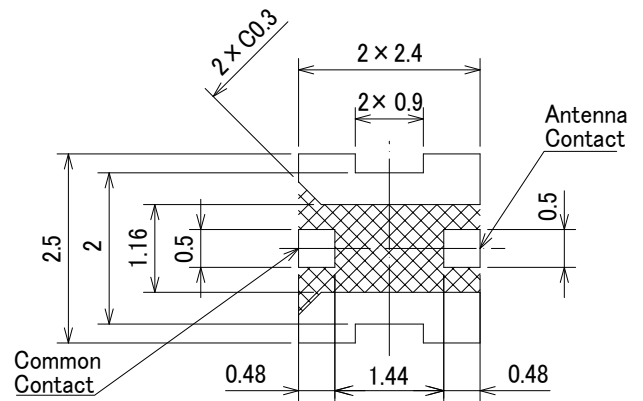

■ Metal Mask Dimensions (Thickness : 0.1 mm)

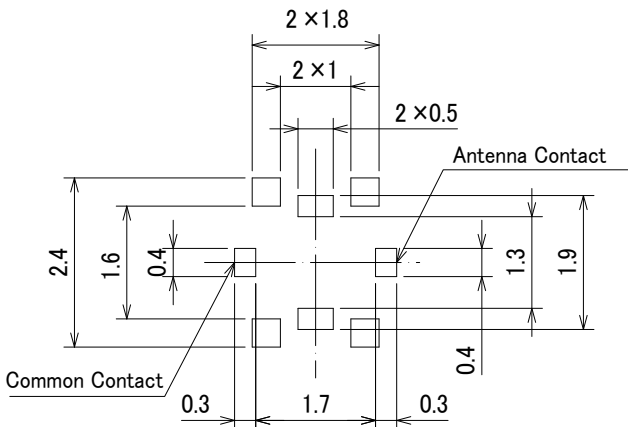

Note 1 : Do not mounting this product using PCB patterns or metal mask dimensions other than the ones specified. It may result in a product malfunction due to solder and/or flux wicking.

Note 2 : Cross-hatched area shown on the PCB mounting pattern must be free of any conductive traces. Placing conductive traces in this area may affect performance and will void product warranties.

Packaging Specifications

Embossed Carrier Tape Dimensions

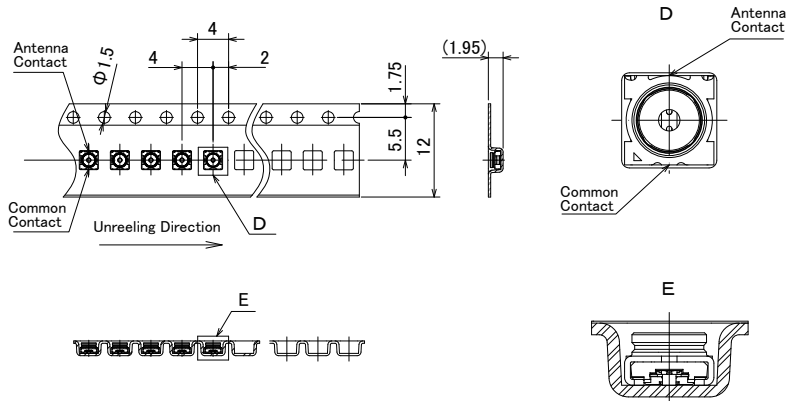

Reel Dimensions

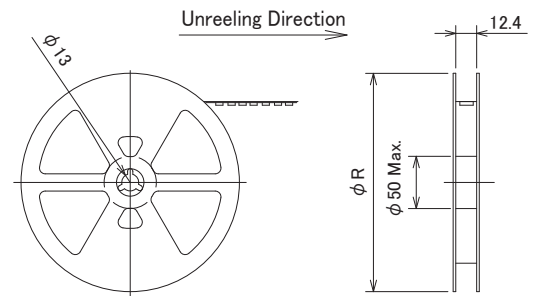

Part No.	Reel Outer Diameter R	Purchase Unit
MS-156C3	$\phi 380$	10,000pcs per reel
MS-156C3(20)	$\phi 180$	2,000pcs per reel

Recommended Temperature Profile

● Recommended Conditions for Using Lead-Free Solder

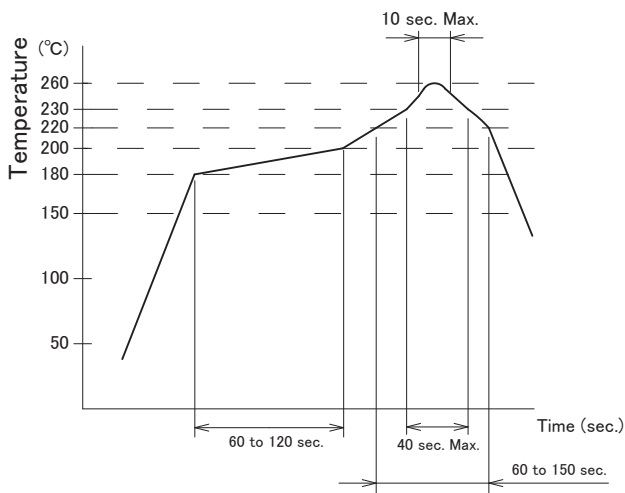

Max Temperature	260°C
Peak Temperature Time	10 sec. Max.
230°C or higher	40 sec. Max.
220°C or higher	60 to 150 sec.
180 to 200°C	60 to 120 sec.

Metal Mask Thickness : $t=0.1\text{mm}$
Number of Reflow : 2 times Max.

Precautions

1. Do not mounting this product using PCB patterns or metal mask dimensions other than the ones specified. It may result in a product malfunction due to solder and/or flux wicking.
2. Cross-hatched area  shown on the PCB mounting pattern must be free of any conductive traces. Placing conductive traces in this area may affect performance and will void product warranties.
3. Do not use hand soldering for mounting of MS-156C3. Doing so could result in solder and flux wicking to the contact areas.
4. If the substrate after MS-156C3 mounting is to be cut off by a router, etc., the web tab should be designed away from MS-156C3 because it may cause item dysfunction due to grinding powder. Also, make sure to suck out the scraping powder so that it does not scatter during the process.

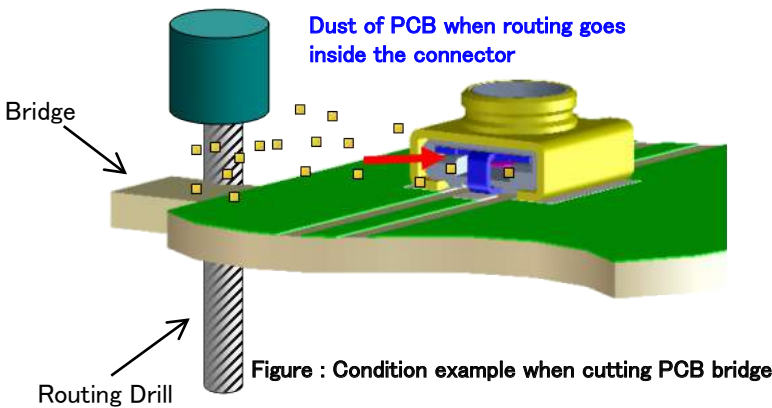
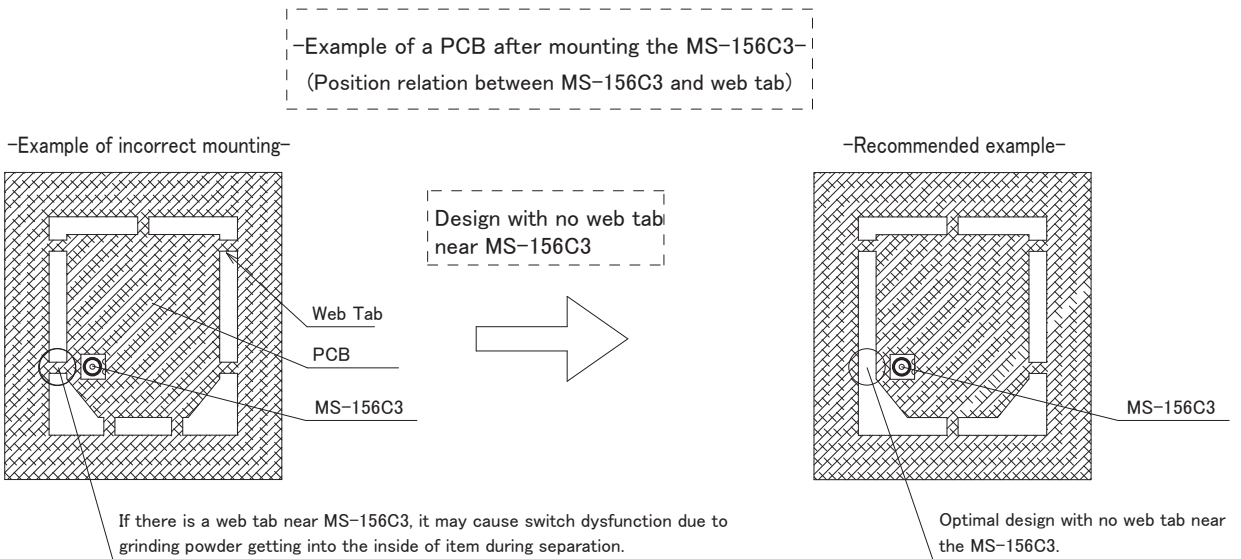

5. This product is intended for use only in testing the circuit. It cannot be used as an interface.
6. Do not use the product in special environments such as dust, high humidity, gas, very high temperature or very low temperature.
7. Plugs can be roughly classified to two types.
 - For mass production line automatic check (Press down type)
 - For manual check (With retentive lock) : Unable to be used at production line.
8. Do not use the washing process.
9. Please use a design in which the device housing does not exert pressure or force on the MS-156C in the event that the finished device is accidentally dropped.
10. Do not apply heat (heat gun or hot plate) over 260°C for more than 10 seconds. Exceeding this thermal limit could cause the resin to melt and cause deformation.
11. When automatic inspections are to be performed during the manufacturing operations, request the MS-156 plug connector manual for examples of implementation.

■ Plug

Order this plug from Cable Assembly Specifications.

Consult your our company sales representative for information on L-length, single-sided coaxial connectors.

● Simplified Lock (Short Type, For Trial Production)

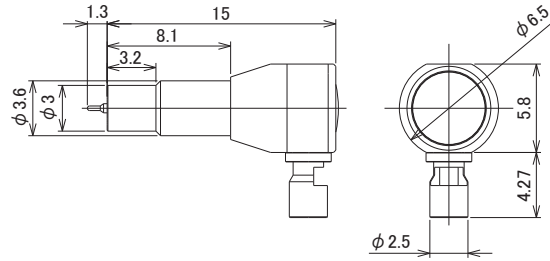

Part No.	HRS No.
MS-156-088LP-H1	CL0358-0268-5-00

Note 1 : An lock mechanism is provided to enable mating and retention with MS-156C3. Keep the mating vertical before use.

Note 2 : This Item is delivered by harness, so please order it from the following Item. Also, please consult us about cable length, installation connector change, etc.

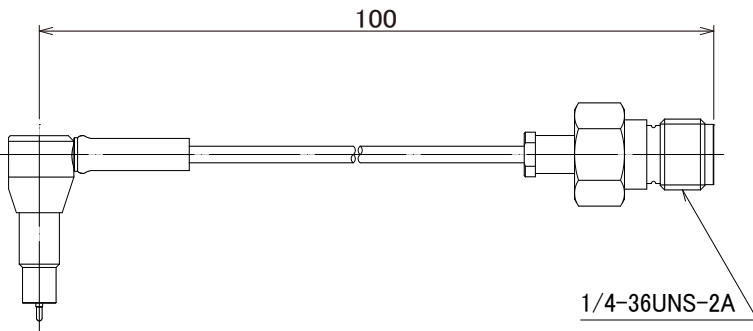

Part No.	HRS No.	Purchase Unit
MS156LH1-HRMJ-088V100A	CL0362-0222-3-01	1pc per bag

● Simplified Lock (Long Type, For Trial Production)

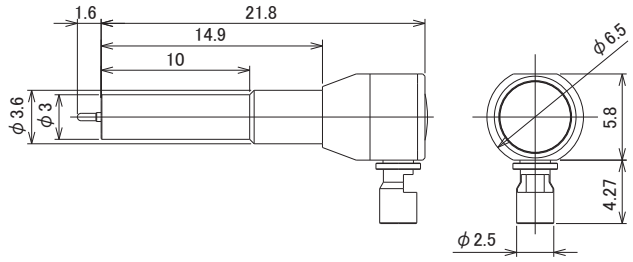

Part No.	HRS No.
MS-156-088LP-H2	CL0358-0275-0-00

Note 1 : An lock mechanism is provided to enable mating and retention with MS-156C3. Keep the mating vertical before use.
 Note 2 : This Item is delivered by harness, so please order it from the following Item. Also, please consult us about cable length, installation connector change, etc.

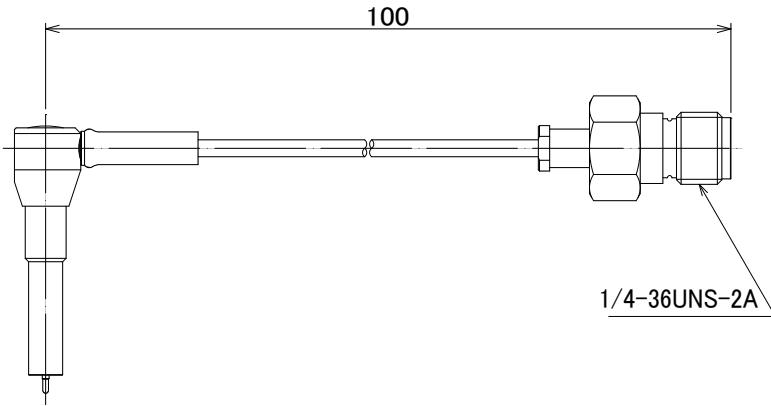

Part No.	HRS No.	Purchase Unit
MS156LH2-HRMJ-088V100	CL0362-0017-0-01	1pc per bag

Aug. 1. 2024 Copyright 2024 HIROSE ELECTRIC CO., LTD. All Rights Reserved.

● Simplified Lock (Antenna Connection Type)

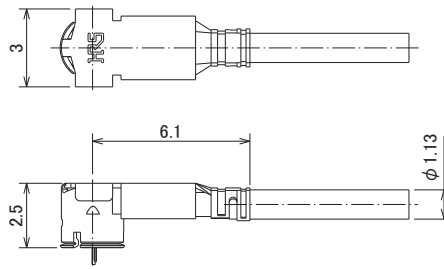
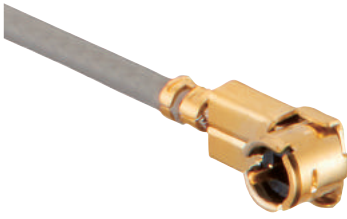

Part No.	HRS No.
MS-156C-LP-068	CL0358-0276-3-00

Note 1 : An lock mechanism is provided to enable mating and retention with MS-156C3.

Note 2 : This Item is delivered by harness, so please order it from the following Item. Also, please consult us about cable length, installation connector change, etc.

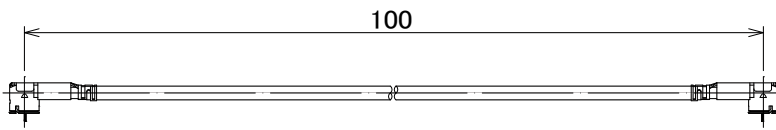

Part No.	HRS No.	Purchase Unit
MS156CLP-2LP-068N1T100	CL0362-0912-1-01	1pc per bag

■ SMA Conversion Adapter

● Simplified Lock (For Trial Production)

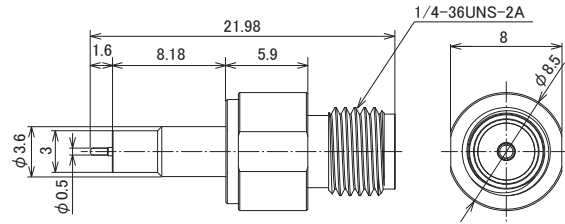

Part No.	HRS No.	Purchase Unit
MS-156-HRMJ-H1	CL0358-0290-4-00	20pcs per bag

Note : An lock mechanism is provided to enable mating and retention with MS-156C3. Keep the mating vertical before use.

● Press Down Type with Flange (For Mass Production)

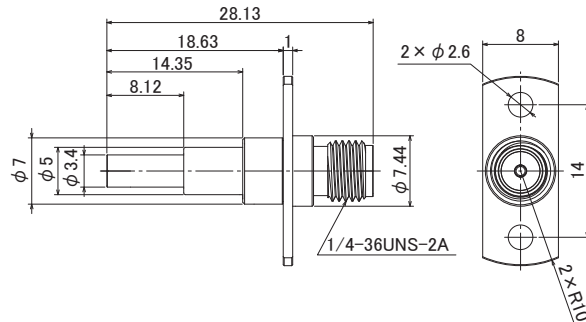
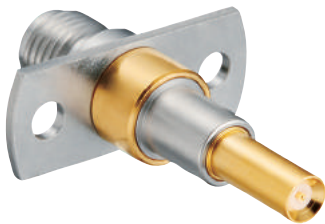

Part No.	HRS No.	Purchase Unit
MS-156-HRMJ-3A	CL0358-0325-7-00	20pcs per bag

Note 1 : Mating MS-156C3 vertically with 6 to 10N.

Note 2 : Proving jig need to equipped with floating capability and spring feature.

● Floating Type (For Mass Production)

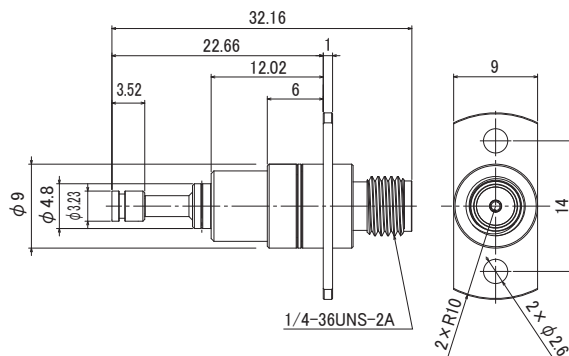
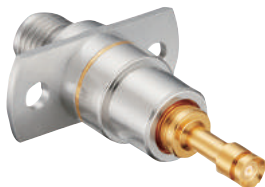

Part No.	HRS No.	Purchase Unit
MS-156-HRMJ-F6	CL0358-0352-0-00	20pcs per bag

Note : Mating vertically with MS-156C3 and use within the specified stroke (1mm to 2mm).

■ Plug Measuring Adapter

This adapter is used to measure plugs for MS-156C3.

● SMA Conversion Type

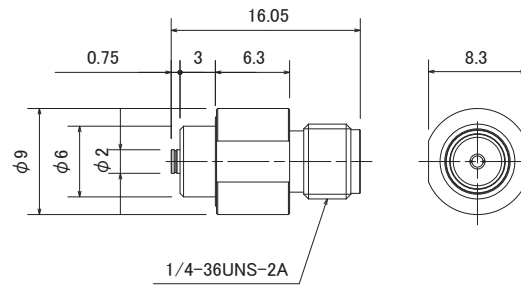

Part No.	HRS No.	Purchase Unit
MS-156R-HRMJ-1	CL0358-0188-8-00	20pcs per bag

● N Conversion Type

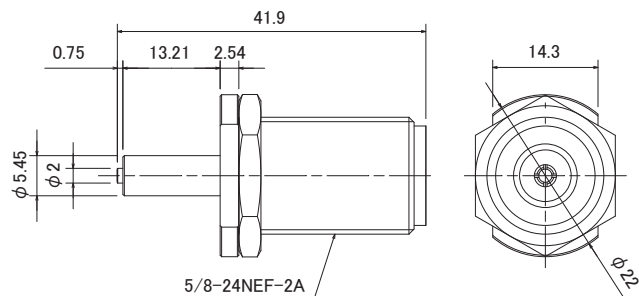

Part No.	HRS No.	Purchase Unit
MS-156R-NJ-1	CL0358-0176-9-00	10pcs per box

While Taking into Consideration

Specifications mentioned in this catalog are reference values.

When considering to order or use this product, please review the Drawing and Product Specifications sheets.

Use an appropriate cable when using the connector in combination with cables.

If considering usage of a non-specified cable, please contact your sales representative.

If assembly process is done by jigs & tools which are not identified by Hirose, the warranty of the product may be affected.

If considering usage for below mentioned applications, please contact your sales representative.

In cases where the application will demand a high level of reliability, such as automotive, medical instruments, public infrastructure, aerospace/defense etc. Hirose must review before assurance of reliability can be given.

HIROSE

HRS

HIROSE ELECTRIC CO.,LTD.

2-6-3 Nakagawa Chuoh, Tsuzuki-Ku, Yokohama-Shi 224-8540, JAPAN
<https://www.hirose.com>

* The contents of this catalog are current as of date of 7/2023. Contents are subject to change without notice for the purpose of improvements.
 * The HRS logo and "HIROSE" are trademarks of HIROSE ELECTRIC CO., LTD.