

QPD W 4PE1,5 M25 FC BK - Panel feed-through



1414738

<https://www.phoenixcontact.com/us/products/1414738>

Please be informed that the data shown in this PDF document is generated from our online catalog. Please find the complete data in the user documentation. Our general terms of use for downloads are valid.



Panel feed-through, product family: QPD, connection method: Spade connection (For slip-on sleeves according to DIN 46247-2), number of positions: 4+PE, M25, 0.5 mm² ... 1.5 mm², 690 V, 17.5 A, PA, black, without QUICKON nut, coding: Coding profile, 1.5 mm²

Your advantages

- Innovative and time saving - QUICKON fast connection for time saving of up to 80 % for on-site connection
- Robust throughout: housing with IP68/IP69K and IK07 protection for a wide range of applications
- Safer connection with mechanical coding to protect against mismatching, and touch-proof protection in accordance with DIN EN 0105
- Efficient - by using panel feed-throughs, devices no longer need to be opened in order to connect cables

Commercial data

Item number	1414738
Packing unit	1 pc
Minimum order quantity	1 pc
Sales key	BF50
Product key	BF6ACA
Catalog page	Page 478 (C-2-2019)
GTIN	4055626033532
Weight per piece (including packing)	26.7 g
Weight per piece (excluding packing)	25.01 g
Customs tariff number	85366990
Country of origin	PL

QPD W 4PE1,5 M25 FC BK - Panel feed-through



1414738

<https://www.phoenixcontact.com/us/products/1414738>

Technical data

Product properties

Product type	Panel feed-through
Product family	QPD
Type	QPD 5x1,5
Number of positions	5
Connection profile	4+PE
Position marking	1, 2, 3, N, PE
Number of connections	10
Number of connections per position	1
Coding	Coding profile

Data management status

Article revision	01
------------------	----

Insulation characteristics

Overvoltage category	III
Degree of pollution	3

Connection data

Connection technology

Connection method On the device side	Spade connection (For slip-on sleeves according to DIN 46247-2)
Frequency of connections between conductors of the same cross section	max. 10

Conductor connection

Conductor cross section flexibel	0.5 mm ² ... 1.5 mm ²
Conductor cross section solid	0.5 mm ² ... 1.5 mm ²
Connection cross section AWG	20 ... 16
Tightening torque Union nut	8 Nm
Tightening torque Locking nut	5 Nm

Dimensions

Dimensional drawing	
Width	30 mm
Height	30 mm
Length	47.9 mm
Diameter	30 mm
Dimensions of slip-on connection	4.8 x 0.8 mm

QPD W 4PE1,5 M25 FC BK - Panel feed-through



1414738

<https://www.phoenixcontact.com/us/products/1414738>

Electrical properties

Rated surge voltage (II/2)	8 kV
Rated surge voltage (III/2)	8 kV
Rated surge voltage (III/3)	6 kV
Rated current	17.5 A (in accordance with IEC 61984 at ambient temperature: 30°C)
Contact resistance	< 3 mΩ
rated voltage (II/2)	1000 V
rated voltage (III/2)	1000 V
Rated voltage (III/3)	690 V
Nominal voltage U_N	690 V AC 690 V DC
Nominal current I_N	17.5 A (in accordance with IEC 61984 at ambient temperature: 30°C)

Mechanical properties

Mechanical data

Insertion/withdrawal cycles	max. 50
-----------------------------	---------

Material specifications

Color	black (RAL 9005)
Material Housing	PA
Material Contact	Cu
Material Contact surface	Silver-plated
Flammability rating according to UL 94	V0
Material wire insulation	PVC/PE/TPE/rubber

Cable/line

Structure of individual litz in acc. with VDE 0295 / smallest wire diameter	VDE 0295 class 1 to 6/min. 0.15 mm
Wire diameter including insulation	1.6 mm ... 3 mm
Position marking	1, 2, 3, N, PE
Cable cross section	1.5 mm ²
Material wire insulation	PVC/PE/TPE/rubber

Mounting

Mounting type	Front mounting M25
---------------	--------------------

Environmental and real-life conditions

Ambient conditions

Degree of protection	IP66 IP68 (2 m / 24 h) IP69K
Impact strength	IK07

QPD W 4PE1,5 M25 FC BK - Panel feed-through



1414738

<https://www.phoenixcontact.com/us/products/1414738>

Ambient temperature (operation)	-40 °C ... 100 °C
Temperature when conductor connected	-5 °C ... 50 °C
Ambient temperature (storage/transport)	-40 °C ... 100 °C

QPD W 4PE1,5 M25 FC BK - Panel feed-through



1414738

<https://www.phoenixcontact.com/us/products/1414738>

Drawings

Dimensional drawing

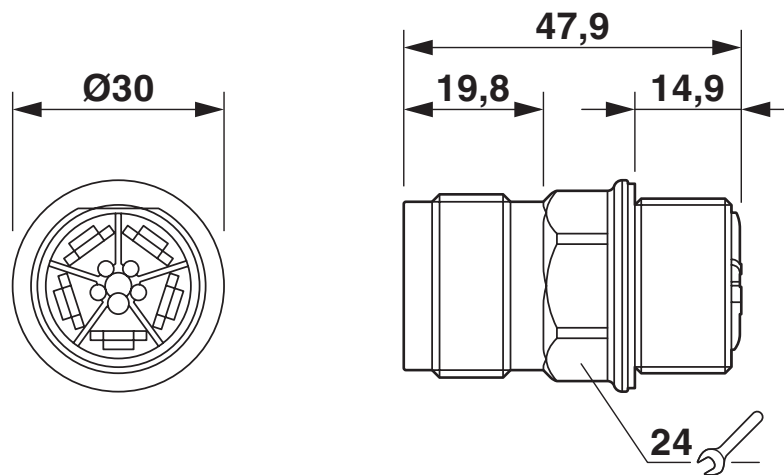

Dimensional drawing



Panel cutout

QPD W 4PE1,5 M25 FC BK - Panel feed-through



1414738

<https://www.phoenixcontact.com/us/products/1414738>

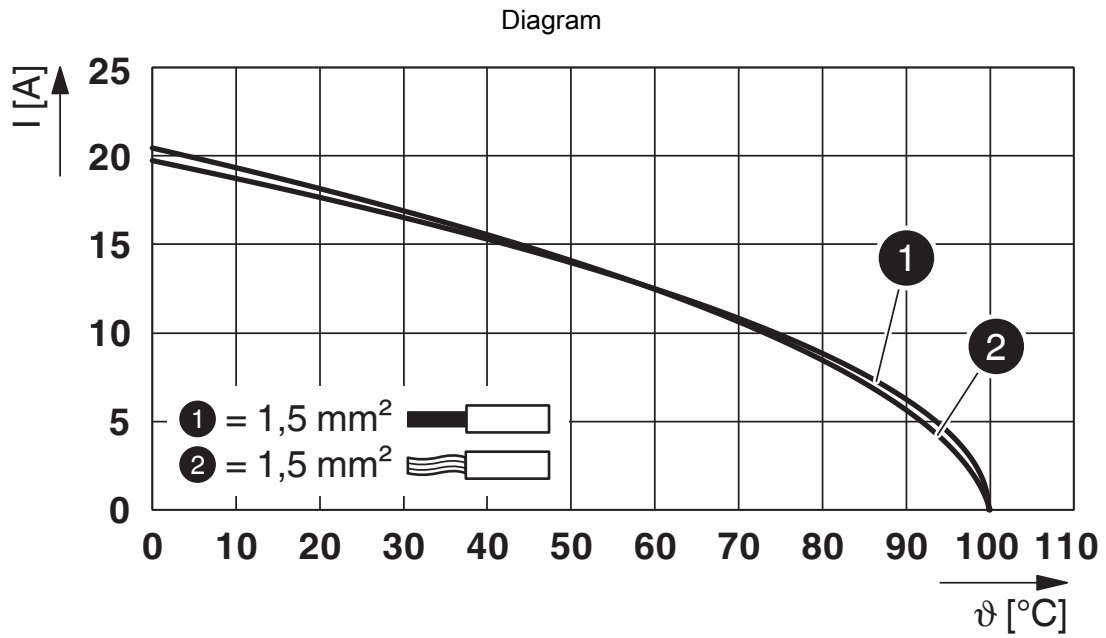

Derating diagram

QPD W 4PE1,5 M25 FC BK - Panel feed-through



1414738

<https://www.phoenixcontact.com/us/products/1414738>

Approvals

To download certificates, visit the product detail page: <https://www.phoenixcontact.com/us/products/1414738>



IECEE CB Scheme
Approval ID: DE1-65875



EAC
Approval ID: RU C-DE.BL08.B.00511



DNV GL
Approval ID: TAE00003J5



VDE Zeichengenehmigung
Approval ID: 40029149



UL Listed
Approval ID: E468743

Nominal voltage U_N	Nominal current I_N	Cross section AWG	Cross section mm^2
600 V	8 A	-	- 16



cUL Listed
Approval ID: E468743

Nominal voltage U_N	Nominal current I_N	Cross section AWG	Cross section mm^2
600 V	8 A	- 16	-

cULus Listed

QPD W 4PE1,5 M25 FC BK - Panel feed-through



1414738

<https://www.phoenixcontact.com/us/products/1414738>

Classifications

ECLASS

ECLASS-11.0	27440602
ECLASS-12.0	27440602
ECLASS-13.0	27440602

ETIM

ETIM 9.0	EC002566
----------	----------

UNSPSC

UNSPSC 21.0	39121500
-------------	----------

QPD W 4PE1,5 M25 FC BK - Panel feed-through



1414738

<https://www.phoenixcontact.com/us/products/1414738>

Environmental product compliance

EU RoHS

Fulfills EU RoHS substance requirements	Yes, No exemptions
---	--------------------

China RoHS

Environment friendly use period (EFUP)	EFUP-E
	No hazardous substances above the limits

EU REACH SVHC

REACH candidate substance (CAS No.)	No substance above 0.1 wt%
-------------------------------------	----------------------------

QPD W 4PE1,5 M25 FC BK - Panel feed-through



1414738

<https://www.phoenixcontact.com/us/products/1414738>

Mandatory accessories

QPD P 4PE1,5 5-10 BK - Connector

1414749

<https://www.phoenixcontact.com/us/products/1414749>



Connector, product family: QPD, connection method: IDC connection, number of positions: 4+PE, 0.5 mm² ... 1.5 mm², 690 V, 17.5 A, PA, black, with QUICKON nut, coding: Coding profile, external cable diameter: 6 mm ... 10 mm

QPD P 4PE1,5 9-14 BK - Connector

1414750

<https://www.phoenixcontact.com/us/products/1414750>



Connector, product family: QPD, connection method: IDC connection, number of positions: 4+PE, 0.5 mm² ... 1.5 mm², 690 V, 17.5 A, PA, black, with QUICKON nut, coding: Coding profile, external cable diameter: 10 mm ... 14 mm

QPD W 4PE1,5 M25 FC BK - Panel feed-through

1414738

<https://www.phoenixcontact.com/us/products/1414738>



QPD N 4PE1,5 5-10 BK - Nut

1415101

<https://www.phoenixcontact.com/us/products/1415101>



Nut, product family: QPD, connection method: IDC connection, number of positions: 4+PE, 0.5 mm² ... 1.5 mm², 690 V, 17.5 A, PA, black, external cable diameter: 6 mm ... 10 mm

Q-MU M25 - Nut

1640715

<https://www.phoenixcontact.com/us/products/1640715>

Nut (plastic) to lock the contact carrier from the inside of the device



Accessories

QPD W 4PE1,5 M25 FC BK - Panel feed-through

1414738

<https://www.phoenixcontact.com/us/products/1414738>



QPD QSK 5X1,5 - Protective cap

1414758

<https://www.phoenixcontact.com/us/products/1414758>

Protective cap plastic, for QPD-QUICKON connection 5x 1.5 mm², IP50



CP-QPD 5X1,5 - Coding profile

1414760

<https://www.phoenixcontact.com/us/products/1414760>

Coding profile red, for pushing into the QUICKON dome and connector, can be positioned in 90° steps.



QPD W 4PE1,5 M25 FC BK - Panel feed-through

1414738

<https://www.phoenixcontact.com/us/products/1414738>



QPD QSK BK 5X1,5 FS - Protective cap

1414728

<https://www.phoenixcontact.com/us/products/1414728>

Protective cap, plastic, for QUICKON connection, black, with retaining cord, IP68



QPD W 4PE1,5 M25 0,5 BK - Panel feed-through

1414736

<https://www.phoenixcontact.com/us/products/1414736>



Panel feed-through, product family: QPD, connection method: Single wires (Welded-on), number of positions: 4+PE, M25, 0.5 mm² ... 1.5 mm², 690 V, 17.5 A, PA, black, without QUICKON nut, coding: Coding profile, 1.5 mm², wires cut flat at the end, cable length: 0.5 m

QPD W 4PE1,5 M25 FC BK - Panel feed-through

1414738

<https://www.phoenixcontact.com/us/products/1414738>



QPD W 4PE1,5 M25 1,0 BK - Panel feed-through

1414737

<https://www.phoenixcontact.com/us/products/1414737>



Panel feed-through, product family: QPD, connection method: Single wires, number of positions: 4+PE, M25, 0.5 mm² ... 1.5 mm², 690 V, 17.5 A, PA, black, without QUICKON nut, coding: Coding profile, 1.5 mm², cable length: 1 m

QPD H 4PE1,5 BK - H distributor

1414757

<https://www.phoenixcontact.com/us/products/1414757>



H distributor, product family: QPD, connection method: IDC connection/ QUICKON fast connection, number of positions: 4+PE, 0.5 mm² ... 1.5 mm², 690 V, 17.5 A, PA, black, without QUICKON nut, coding: Coding profile

QPD W 4PE1,5 M25 FC BK - Panel feed-through



1414738

<https://www.phoenixcontact.com/us/products/1414738>

QPD C 4PE1,5 1X5-10 BK - Conductor connector

1414739

<https://www.phoenixcontact.com/us/products/1414739>



Conductor connector, product family: QPD, connection method: IDC connection, number of positions: 4+PE, 0.5 mm² ... 1.5 mm², 690 V, 17.5 A, PA, black, with one QUICKON nut, coding: Coding profile, external cable diameter: 6 mm ... 10 mm

QPD C 4PE1,5 1X9-14 BK - Conductor connector

1414741

<https://www.phoenixcontact.com/us/products/1414741>



Conductor connector, product family: QPD, connection method: IDC connection, number of positions: 4+PE, 0.5 mm² ... 1.5 mm², 690 V, 17.5 A, PA, black, with one QUICKON nut, coding: Coding profile, external cable diameter: 10 mm ... 14 mm

QPD W 4PE1,5 M25 FC BK - Panel feed-through

1414738

<https://www.phoenixcontact.com/us/products/1414738>



QPD T 4PE1,5 2X5-10 BK - T distributor

1414751

<https://www.phoenixcontact.com/us/products/1414751>



T distributor, product family: QPD, connection method: IDC connection, number of positions: 4+PE, 0.5 mm² ... 1.5 mm², 690 V, 17.5 A, PA, black, With two QUICKON nuts, coding: Coding profile, external cable diameter: 6 mm ... 10 mm

QPD T 4PE1,5 2X9-14 BK - T distributor

1414752

<https://www.phoenixcontact.com/us/products/1414752>



T distributor, product family: QPD, connection method: IDC connection, number of positions: 4+PE, 0.5 mm² ... 1.5 mm², 690 V, 17.5 A, PA, black, With two QUICKON nuts, coding: Coding profile, external cable diameter: 10 mm ... 14 mm

QPD W 4PE1,5 M25 FC BK - Panel feed-through

1414738

<https://www.phoenixcontact.com/us/products/1414738>



QSS 22 - Socket wrench

1670206

<https://www.phoenixcontact.com/us/products/1670206>



Allen wrench, for loosening and fastening the QUICKON union nut, WAF 22 mm

Phoenix Contact 2024 © - all rights reserved

<https://www.phoenixcontact.com>

Phoenix Contact USA
586 Fulling Mill Road
Middletown, PA 17057, United States
(+717) 944-1300
info@phoenixcon.com