

Viewed from component side
 General Tolerance: ±0.05
 Solder Area
 Component Outline

Mating Entry Face

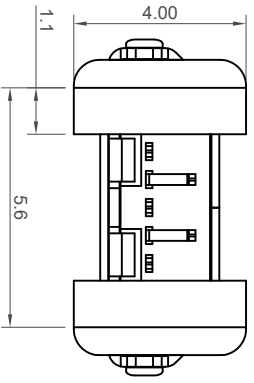
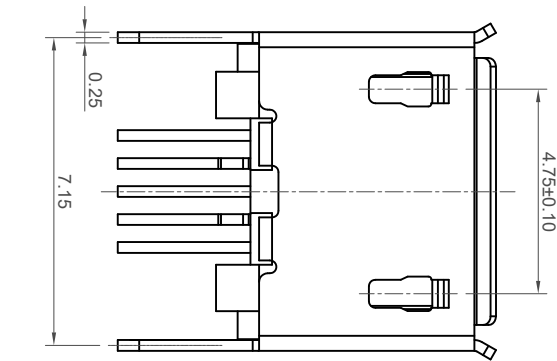
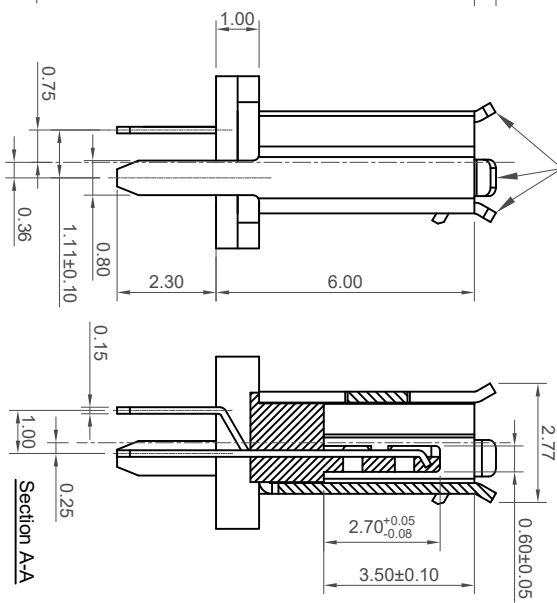
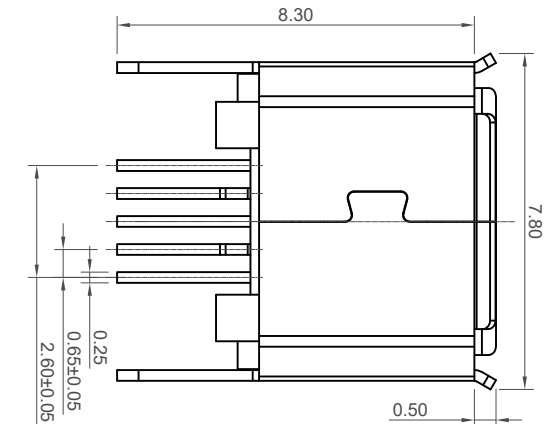

Designed to comply with physical, electrical and environmental requirements of Micro USB Standard (USB2.0)
 Note: Recommended for 1.6mm PCB thickness, for thinner PCB's choose USB3130 (B) or USB3105 (A/B).

Specification 规格

Material 物料
 Plastic Housing 塑胶外壳: LCP, UL94V-0, Black
 Contact Terminal 接触端子: Copper Alloy
 Metallic Shell 金属外壳: Stainless Steel (T=0.25mm)

Plating 电镀

Metallic Shell 金属外壳: Matte Tin
 Underplating 底层电镀: 50µ" Nickel
 Contact Area 接触面积: 30µ" Gold plating
 Solder Tails 焊接末端: Gold Flash

Electrical 电气

Voltage Rating 电压额定值: 30 V AC
 Current Rating 电流额定值: Signal (Pins 2,3,4):1.0 A, Power (Pins1,5):1.8A.
 Operating Temperature 工作温度: -30°C to +85°C.
 Contact Resistance 接触电阻值: 30mΩ max.
 Insulating Resistance 绝缘电阻值: 1000MΩ min.
 Dielectric Withstand Voltage 耐电压: 500V AC/minute

Mechanical & Environmental 机械 & 环境

Mating Force 插入力: 35N max.
 Umating Force 拔出力: 8N min.
 Durability 耐久性: 10,000 Cycles

Ordering Grid

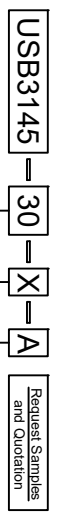

Contact Plating
 30 = 30µ" Gold
 X = Packing Options
 A = Tape & Reel (1300 per reel)

Mating Entry Face
 1 = With Mating Entry Face (Standard)
 0 = Without Mating Entry Face (MOQ = 7800)

Part Number		Product Description	
USB3145		Micro USB Receptacle, Type B, Through Hole, Vertical, With Through Hole Shell Stakes	
Drawing Date		2nd April 2013	
By		CC	
Detail		USB3145 B PCN	
Revision		X.XX ± 0.20 X.XXX ± 0.10 X.XXXX ± 0.05	
Date		17/01/17	
Units:		Metric (mm)	
Tolerances (Except as Noted)		Length X.X ± 0.30 X.XX ± 0.20 X.XXX ± 0.10 X.XXXX ± 0.05	
Angles		X.X° ± 2° X.XX° ± 1°	
Units:		Imperial (Inches)	
Metric (mm)		Imperial (Inches)	
RoHS COMPLIANT		The drawing must not be copied or retransmitted in any form without the written consent of GCT.	
www.gct.co		Not to Scale	
Drawn By ASE		Sheet No. 1/2	

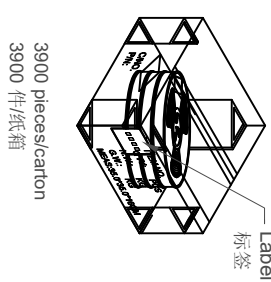
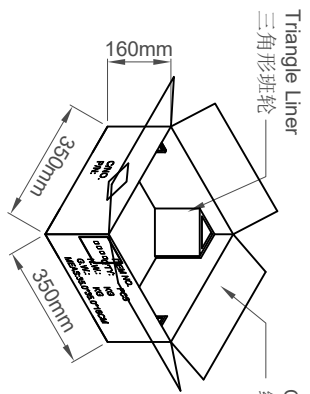
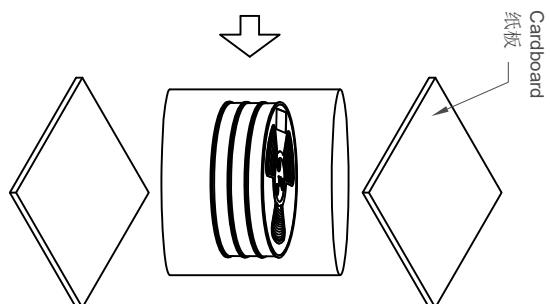
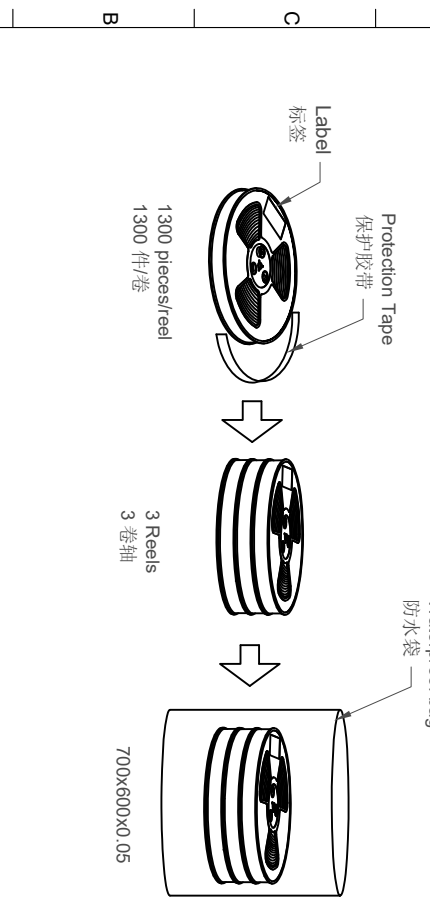
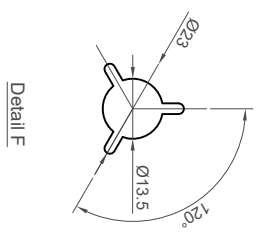
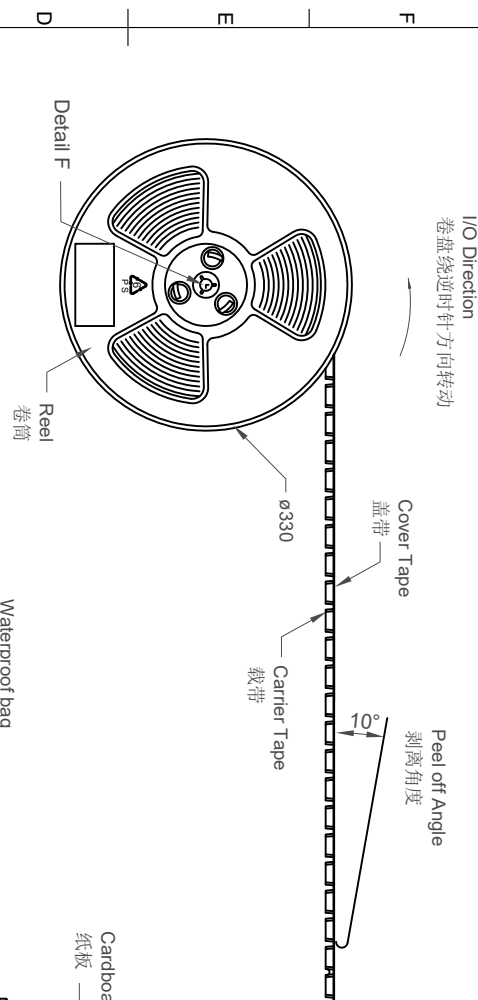
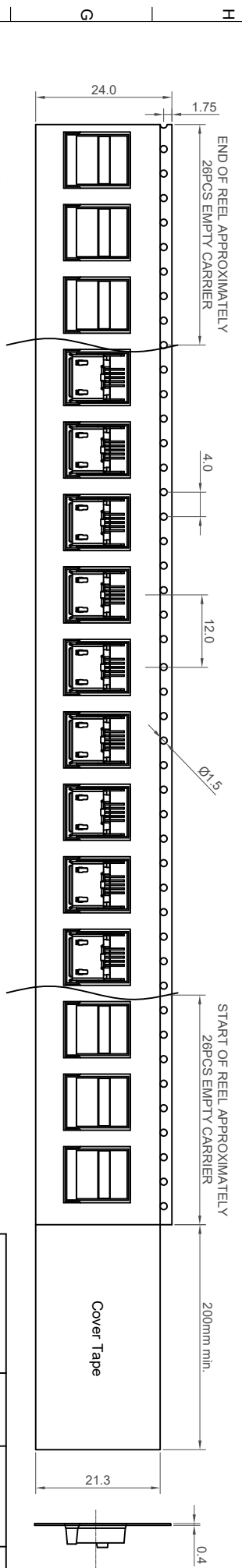

Part Number		Product Description		Revision		Scale	
USB3145		Micro USB Receptacle, Type B, Through Hole, Vertical, With Through Hole Shell Stakes		5		A	
Drawing Date		By		Date		Scale	
2nd April 2013		CC		17/01/17		A	
Detail		Length		Metric (mm)		Scale	
B2		X.X ± 0.30		X.X ± 0.20		A	
Revision		Angle		Metric (mm)		Scale	
5		X.XX ± 1°		X.XX ± 0.20		A	
Date		Tolerances (Except as Noted)		Metric (mm)		Scale	
17/01/17		X.XXX ± 0.10 X.XXX ± 0.05		X.XX ± 0.20		A	

