

## Ultra-Small, Ultra-Low Power MEMS Oscillator

### Features

- Wide Frequency Range: 3.5 kHz to 100 MHz
- Ultra-Low Power Consumption: 3 mA/1  $\mu$ A (Active/Standby)
- Ultra-Small Footprints
  - 1.6 mm x 1.2 mm VFLGA
  - 2.0 mm x 1.6 mm VFLGA
  - 2.5 mm x 2.0 mm VLGA
  - 3.2 mm x 2.5 mm VDFN
  - 5.0 mm x 3.2 mm VDFN
  - 7.0 mm x 5.0 mm VDFN
- Frequency Select Input Supports Two Pre-Defined Frequencies
- High Stability:  $\pm 20$  ppm,  $\pm 25$  ppm,  $\pm 50$  ppm
- Wide Temperature Range
  - Automotive:  $-40^{\circ}\text{C}$  to  $+125^{\circ}\text{C}$
  - Ext. Industrial:  $-40^{\circ}\text{C}$  to  $+105^{\circ}\text{C}$
  - Industrial:  $-40^{\circ}\text{C}$  to  $+85^{\circ}\text{C}$
  - Ext. Commercial:  $-20^{\circ}$  to  $+70^{\circ}\text{C}$
- Excellent Shock and Vibration Immunity
  - Qualified to MIL-STD-883
- High Reliability
  - 20x Better MTF Than Quartz Oscillators
- Supply Range of 1.71V to 3.63V
- Short Sample Lead Time: <2 weeks
- Lead Free & RoHS Compliant
- Automotive Version Available: DSA61xxB

### Applications

- Low Power/Portable Applications: IoT, Embedded/Smart Devices
- Consumer: Home Healthcare, Fitness Devices, Home Automation
- Industrial: Building/Factory Automation, Surveillance Camera
- Automotive (Please Refer to the DSA61xx Family)

### General Description

The DSC61xxB family of MEMS oscillators combines the industry leading low power consumption and ultra-small packages with exceptional frequency stability and jitter performance over temperature. The single-output DSC61xxB MEMS oscillators are excellent choices for use as clock references in small, battery-powered devices such as wearable and Internet of Things (IoT) devices in which small size, low power consumption, and long-term reliability are paramount.

The DSC61xxB family is available in 1.6 mm x 1.2 mm & 2.0 mm x 1.6 mm VFLGA, 7.0 mm x 5.0 mm, 5.0 mm x 3.2 mm & 3.2 mm x 2.5 mm VDFN, and 2.5 mm x 2.0 mm VLGA packages. These packages are “drop-in” replacements for standard 4-pin CMOS quartz crystal oscillators. The Automotive Grade AEC-Q100 qualified option is also available for this device.

### Package Types

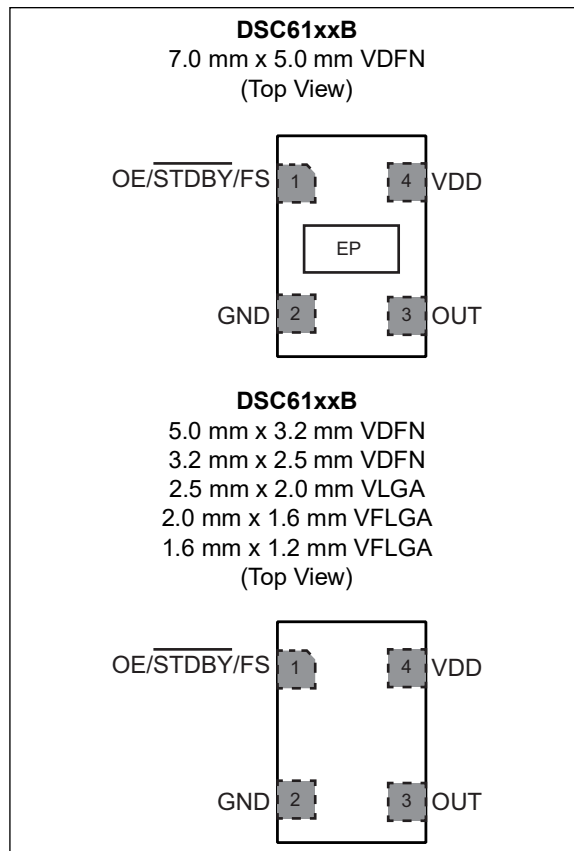

# DSC61XXB

## Block Diagram

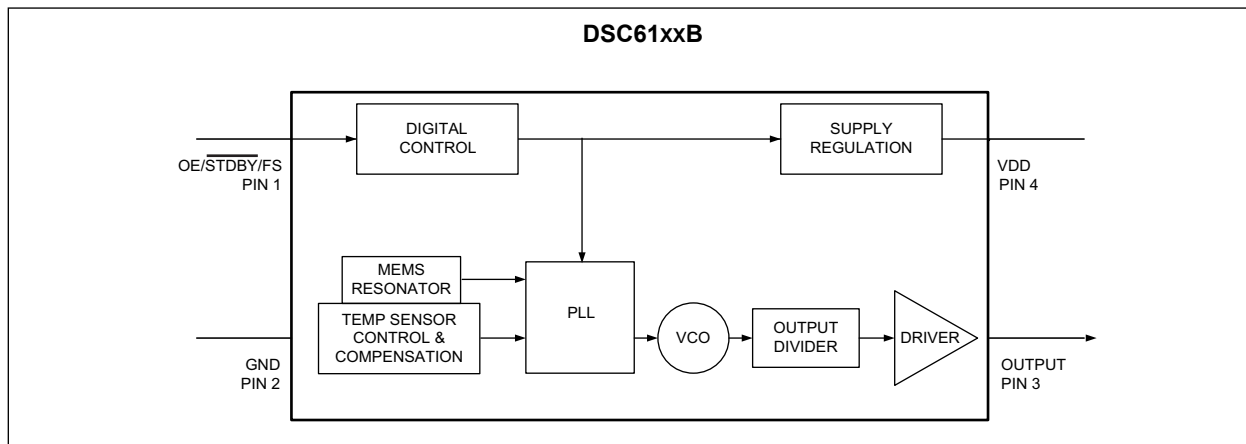

## 1.0 ELECTRICAL CHARACTERISTICS

### Absolute Maximum Ratings

Supply Voltage .....	-0.3V to +4.0V
Input Voltage ( $V_{IN}$ ) .....	-0.3V to $V_{DD}+0.3V$
ESD Protection .....	4 kV HBM, 400V MM, 2 kV CDM

### ELECTRICAL CHARACTERISTICS

Electrical Characteristics: Unless otherwise indicated, $V_{DD} = 1.8V -5\%$ to $3.3V +10\%$ , $T_A = -40^{\circ}C$ to $+125^{\circ}C$ .						
Parameters	Sym.	Min.	Typ.	Max.	Units	Conditions
Supply Voltage	$V_{DD}$	1.71	—	3.63	V	Note 1
Power Supply Ramp	$t_{PU}$	0.1	—	100	ms	Note 8
Active Supply Current	$I_{DD}$	—	3.0	—	mA	$f_{OUT} = 27$ MHz, $V_{DD} = 1.8V$ , No Load
Standby Supply Current	$I_{STBY}$	—	1	—	$\mu A$	$V_{DD} = 1.8/2.5V$ , Note 2
		—	1.5	—		$V_{DD} = 3.3V$ , Note 2
Output Duty Cycle	SYM	45	—	55	%	—
Frequency	$f_0$	0.0035	—	100	MHz	—
Frequency Stability	$\Delta f$	—	—	$\pm 20$ $\pm 25$ $\pm 50$	ppm	All temp ranges, Note 3
Aging	$\Delta f$	—	—	$\pm 5$	ppm	1st year @ $25^{\circ}C$
		—	—	$\pm 1$		Per year after first year
Startup Time	$t_{SU}$	—	—	1.5	ms	From 90% $V_{DD}$ to valid clock output, $T = 25^{\circ}C$
Input Logic Levels	$V_{IH}$	$0.7 \times V_{DD}$	—	—	V	Input Logic High, Note 4
	$V_{IL}$	—	—	$0.3 \times V_{DD}$	V	Input Logic Low, Note 4
Output Disable Time	$t_{DA}$	—	—	200 + 2 Periods	ns	Note 5
Output Enable Time	$t_{EN}$	—	—	1	$\mu s$	Note 6
Enable Pull-up Resistor	—	—	300	—	k $\Omega$	If configured, Note 7

- Note 1:** Pin 4  $V_{DD}$  should be filtered with 0.1  $\mu F$  capacitor.
- 2:** Not including current through pull-up resistor on EN pin (if configured). Higher standby current seen at  $>3.3V V_{DD}$ .
- 3:** Includes frequency variations due to initial tolerance, temp. and power supply voltage.
- 4:** Input waveform must be monotonic with rise/fall time  $< 10$  ms
- 5:** Output Disable time takes up to two periods of the output waveform + 200 ns.
- 6:** For parts configured with OE, not Standby.
- 7:** Output is enabled if pad is floated or not connected.
- 8:** Time to reach 90% of target  $V_{DD}$ . Power ramp rise must be monotonic.

# DSC61XXB

## ELECTRICAL CHARACTERISTICS (CONTINUED)

Electrical Characteristics: Unless otherwise indicated, $V_{DD} = 1.8V -5\%$ to $3.3V +10\%$ , $T_A = -40^{\circ}C$ to $+125^{\circ}C$ .							
Parameters	Sym.	Min.	Typ.	Max.	Units	Conditions	
Output Logic Levels	$V_{OH}$	$0.8 \times V_{DD}$	—	—	V	Output Logic High, $I = 3$ mA, Std. Drive	
						Output Logic High, $I = 6$ mA, High Drive	
	$V_{OL}$	—	—	$0.2 \times V_{DD}$	V	Output Logic Low, $I = -3$ mA, Std. Drive	
						Output Logic Low, $I = -6$ mA, High Drive	
Output Transition Time Rise Time/Fall Time	$t_{RX}/t_{FX}$	—	1	1.5	ns	DSC61x2 High Drive, 20% to 80% $C_L = 15$ pF	$V_{DD} = 1.8V$
			0.5	1.0	ns		$V_{DD} = 2.5V/3.3V$
	$t_{RY}/t_{FY}$	—	1.2	2.0	ns	DSC61x1 Std Drive, 20% to 80% $C_L = 10$ pF	$V_{DD} = 1.8V$
			0.6	1.2	ns		$V_{DD} = 2.5V/3.3V$
Period Jitter, RMS	$J_{PER}$	—	8.5	—	$ps_{RMS}$	$f_{OUT} = 27$ MHz	$V_{DD} = 1.8V$
			7	—			$V_{DD} = 2.5V/3.3V$
Cycle-to-Cycle Jitter (Peak)	$J_{Cy-Cy}$	—	50	70	ps	$f_{OUT} = 27$ MHz	$V_{DD} = 1.8V$
			35	60			$V_{DD} = 2.5V/3.3V$
Period Jitter (Peak-to-Peak)	$J_{PP}$	—	70	—	ps	$f_{OUT} = 27$ MHz	$V_{DD} = 1.8V$
			60	—			$V_{DD} = 2.5V/3.3V$

- Note 1:** Pin 4  $V_{DD}$  should be filtered with 0.1  $\mu F$  capacitor.
- 2:** Not including current through pull-up resistor on EN pin (if configured). Higher standby current seen at  $>3.3V V_{DD}$ .
- 3:** Includes frequency variations due to initial tolerance, temp. and power supply voltage.
- 4:** Input waveform must be monotonic with rise/fall time  $< 10$  ms
- 5:** Output Disable time takes up to two periods of the output waveform + 200 ns.
- 6:** For parts configured with OE, not Standby.
- 7:** Output is enabled if pad is floated or not connected.
- 8:** Time to reach 90% of target  $V_{DD}$ . Power ramp rise must be monotonic.

## TEMPERATURE SPECIFICATIONS (Note 1)

Parameters	Sym.	Min.	Typ.	Max.	Units	Conditions
<b>Temperature Ranges</b>						
Junction Operating Temperature	$T_J$	-40	—	+150	°C	—
Storage Ambient Temperature Range	$T_A$	-55	—	+150	°C	—
Soldering Temperature	$T_S$	—	+260	—	°C	40 sec. max.

**Note 1:** The maximum allowable power dissipation is a function of ambient temperature, the maximum allowable junction temperature and the thermal resistance from junction to air (i.e.,  $T_A$ ,  $T_J$ ,  $\theta_{JA}$ ). Exceeding the maximum allowable power dissipation will cause the device operating junction temperature to exceed the maximum +125°C rating. Sustained junction temperatures above +125°C can impact the device reliability.

# DSC61XXB

## 2.0 PIN DESCRIPTIONS

The DSC61xxB is a highly configurable device and can be factory programmed in many different ways to meet the customer's needs. Microchip's ClockWorks® Configurator <http://clockworks.microchip.com/Timing/> must be used to choose the necessary options, create the final part number, data sheet, and order samples. The descriptions of the pins are listed in [Table 2-1](#).

**TABLE 2-1: DSC61XXB PIN FUNCTION TABLE**

Pin Number	Pin Name	Description
1 (Note 1)	OE	Output Enable: H = Active, L = Disabled (High Impedance).
	$\overline{\text{STDBY}}$	Standby: H = Device is active, L = Device is in standby (Low Power Mode).
	FS	Frequency Select: H = Output Frequency 1, L = Output Frequency 2.
2	GND	Ground.
3	Output	Oscillator clock output.
4	VDD	Power supply: 1.71V to 3.63V.

**Note 1:** DSC610xB/1xB/3xB has a 300 k $\Omega$  internal pull-up resistor on pin 1. DSC614xB/5xB/7xB has no internal pull-up resistor on pin 1 and needs an external pull-up or to be driven by another chip.

An explanation of the different options listed in [Table 2-1](#) follows.

### 2.1 Pin 1

This is a control pin and may be configured to fulfill one of three different functions. If not actively driven, a 10 k $\Omega$  pull-up resistor is recommended.

#### 2.1.1 OUTPUT ENABLE (OE)

Pin 1 may be configured as OE. Oscillator output may be turned on and off according to the state of this pin.

#### 2.1.2 $\overline{\text{STDBY}}$

Pin 1 may be configured as Standby. When the pin is low, both output buffer and PLL will be off and the device will enter a low power mode.

#### 2.1.3 FREQUENCY SELECT (FS)

Pin 1 may be configured as FS. The output may be set to one of two pre-programmed frequencies. The output clock frequencies can only be set to either kHz or MHz. A combination of kHz and MHz cannot be set.

### 2.2 Pins 2 through 4

Pins 2 and 4 are the supply terminals, GND and VDD respectively. Pin 3 is the clock output, programmable to Standard and High Drive strength settings. Visit [ClockWorks® Configurator](#) to customize your device.

### 2.3 Output Buffer Options

The DSC61xx family is available in multiple output driver configurations.

The standard-drive (61x1) and high-drive (61x2) deliver respective output currents of greater than 3 mA and 6 mA at 20%/80% of the supply voltage. For heavy loads of 15 pF or higher, the high-drive option is recommended.

## 3.0 DIAGRAMS

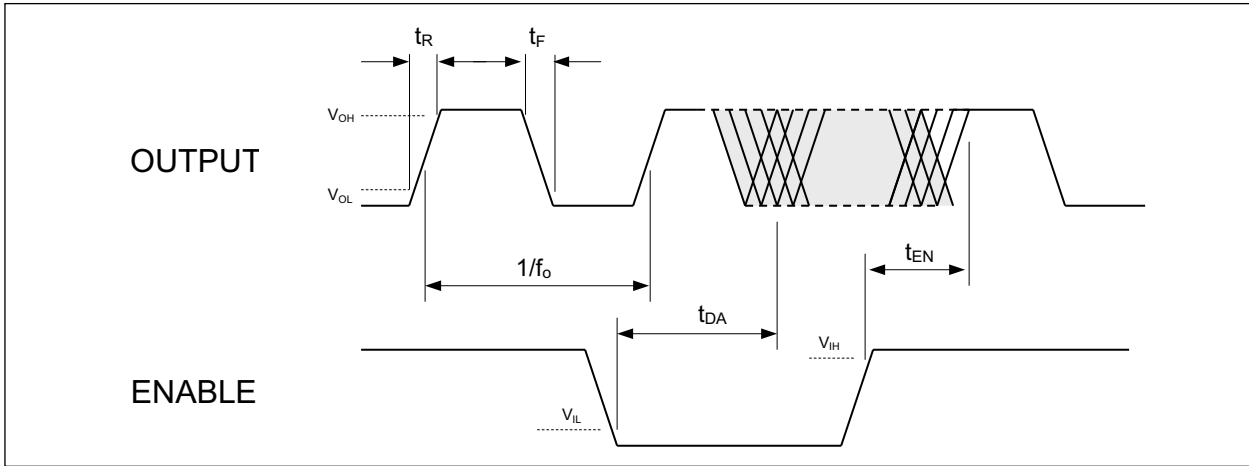

**FIGURE 3-1:** Output Waveform.

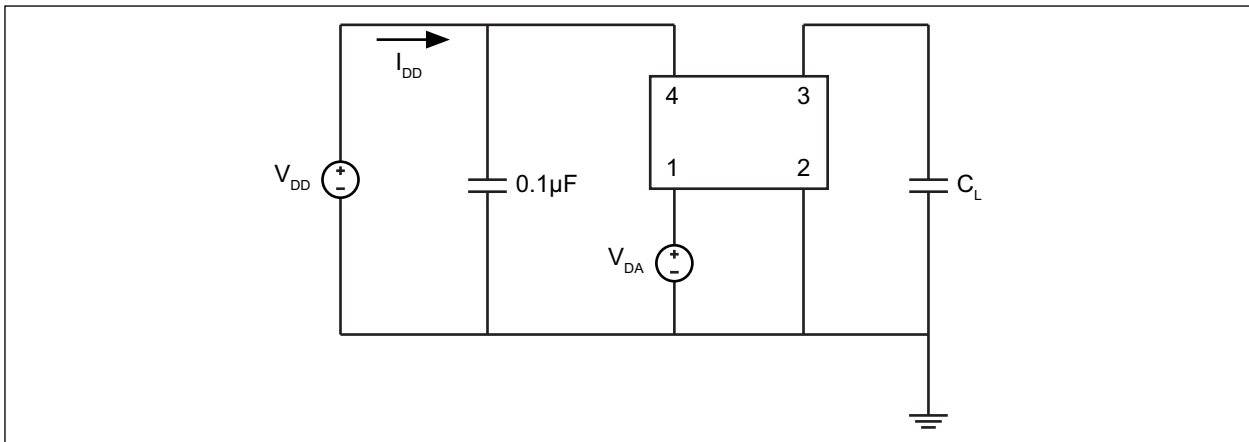

**FIGURE 3-2:** Test Circuit.

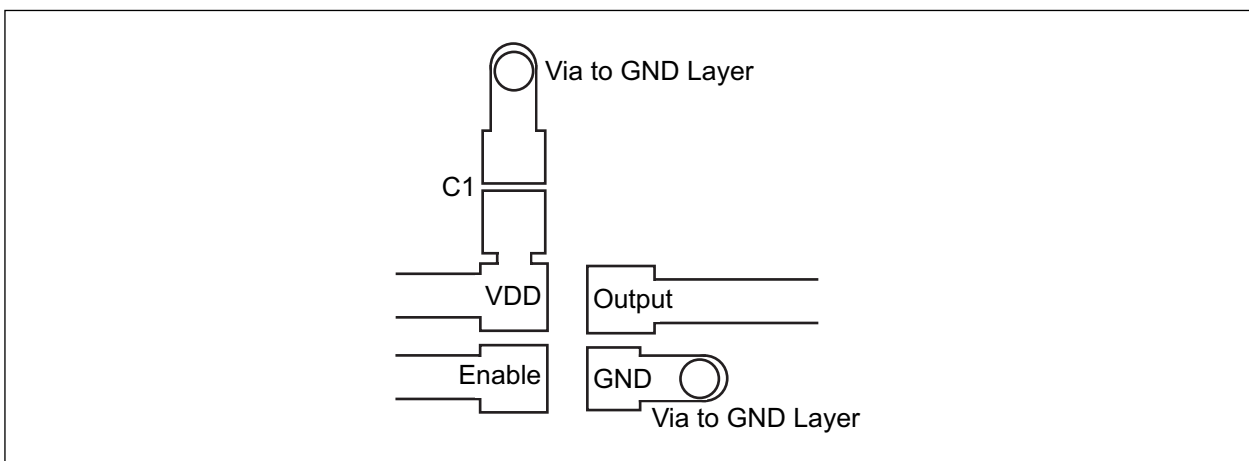

**FIGURE 3-3:** Recommended Board Layout.

# DSC61XXB

## 4.0 SOLDER REFLOW PROFILE

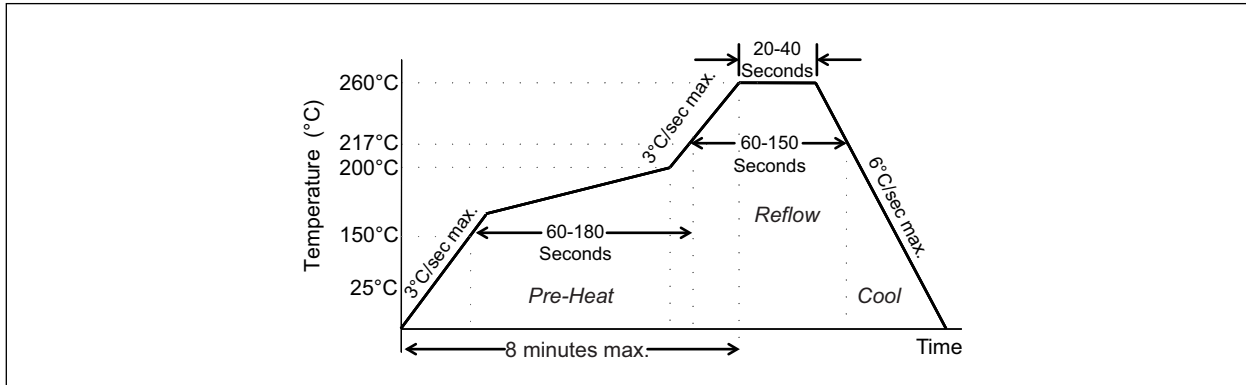

**FIGURE 4-1:** Solder Reflow Profile.

<b>MSL 1 @ 260°C refer to JSTD-020C</b>	
Ramp-Up Rate (200°C to Peak Temp)	3°C/sec. max.
Preheat Time 150°C to 200°C	60 to 180 sec.
Time maintained above 217°C	60 to 150 sec.
Peak Temperature	255°C to 260°C
Time within 5°C of actual Peak	20 to 40 sec.
Ramp-Down Rate	6°C/sec. max.
Time 25°C to Peak Temperature	8 minutes max.

## 5.0 PACKAGING INFORMATION

### 5.1 Package Marking Information

#### 4-Lead

7.0mm x 5.0mm VDFN\*  
 5.0mm x 3.2mm VDFN\*  
 3.2mm x 2.5mm VDFN\*  
 2.5mm x 2.0mm VLGA\*

#### Example

XXXXXXX  
 XXXYYWW  
 0SSS

0400000  
 DCP1834  
 0287

4-Lead VFLGA\*  
 2.0mm x 1.6mm  
 1.6mm x 1.2mm

#### Example

XXXX  
 SSS

011H  
 502

<b>Legend:</b>	<p>XX...X Product code or customer-specific information</p> <p>Y Year code (last digit of calendar year)</p> <p>YY Year code (last 2 digits of calendar year)</p> <p>WW Week code (week of January 1 is week '01')</p> <p>SSS Alphanumeric traceability code</p> <p>(e3) Pb-free JEDEC® designator for Matte Tin (Sn)</p> <p>* This package is Pb-free. The Pb-free JEDEC designator ((e3)) can be found on the outer packaging for this package.</p> <p>•, ▲, ▼ Pin one index is identified by a dot, delta up, or delta down (triangle mark).</p>
<b>Note:</b>	<p>In the event the full Microchip part number cannot be marked on one line, it will be carried over to the next line, thus limiting the number of available characters for customer-specific information. Package may or may not include the corporate logo.</p> <p>Underbar ( _ ) and/or Overbar ( ¯ ) symbol may not be to scale.</p>

# DSC61XXB

## 4-Lead Very Thin Dual Flatpack, No Lead Package (JZA) - 7x5x0.9 mm Body [VDFN] With 2.2x3.5 mm Exposed Pad

**Note:** For the most current package drawings, please see the Microchip Packaging Specification located at <http://www.microchip.com/packaging>

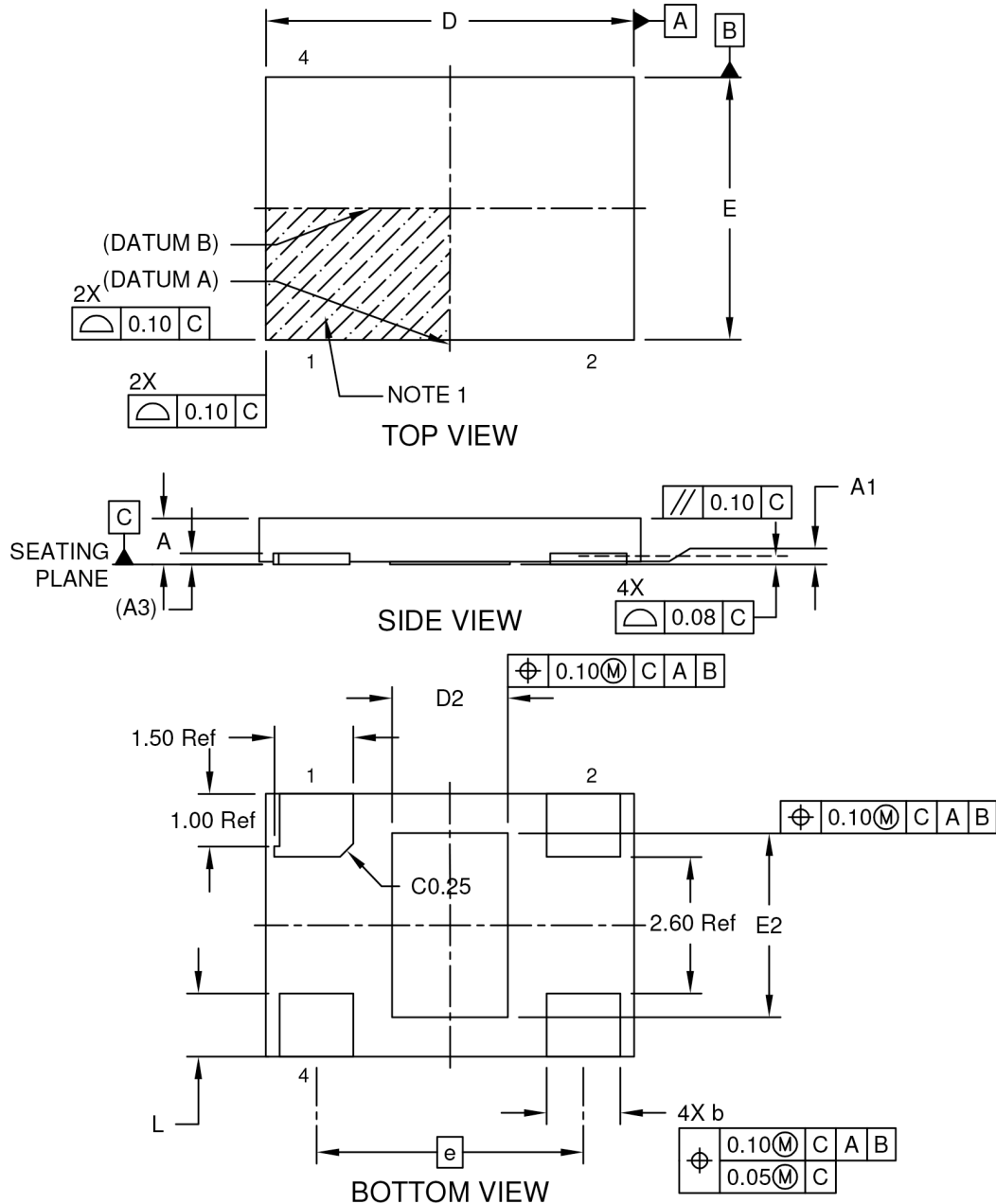

Microchip Technology Drawing C04-1025 Rev A Sheet 1 of 2

## 4-Lead Very Thin Dual Flatpack, No Lead Package (JZA) - 7x5x0.9 mm Body [VDFN] With 2.2x3.5 mm Exposed Pad

**Note:** For the most current package drawings, please see the Microchip Packaging Specification located at <http://www.microchip.com/packaging>

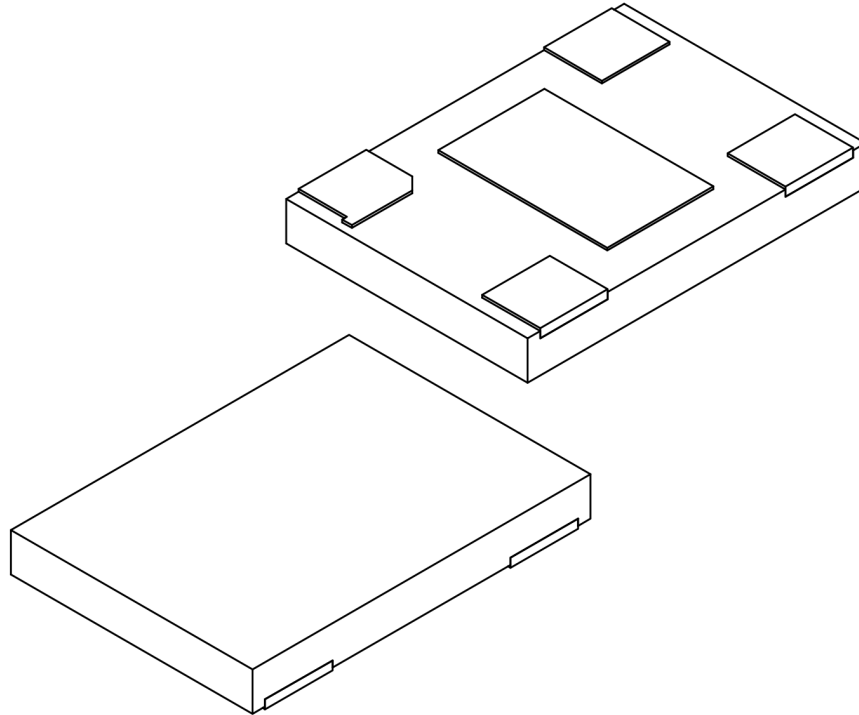

Units		MILLIMETERS		
Dimension Limits		MIN	NOM	MAX
Number of Terminals	N	004		
Pitch	e	5.08 Ref		
Overall Height	A	0.80	0.85	0.90
Standoff	A1	0.00	-	0.05
Terminal Thickness	A3	0.203 Ref		
Overall Length	D	6.90	7.00	7.10
Exposed Pad Length	D2	2.10	2.20	2.30
Overall Width	E	4.90	5.00	5.10
Exposed Pad Width	E2	3.40	3.50	3.60
Terminal Width	b	1.35	1.40	1.45
Terminal Length	L	1.10	1.20	1.30

**Notes:**

- Pin 1 visual index feature may vary, but must be located within the pin 1 area.
- Package is saw singulated
- Dimensioning and tolerancing per ASME Y14.5M  
 BSC: Basic Dimension. Theoretically exact value shown without tolerances.  
 REF: Reference Dimension, usually without tolerance, for information purposes only.

# DSC61XXB

## 4-Lead Very Thin Dual Flatpack, No Lead Package [JZA] - 7x5x0.9 mm Body [VDFN] With 2.2x3.5 mm Exposed Pad

**Note:** For the most current package drawings, please see the Microchip Packaging Specification located at <http://www.microchip.com/packaging>

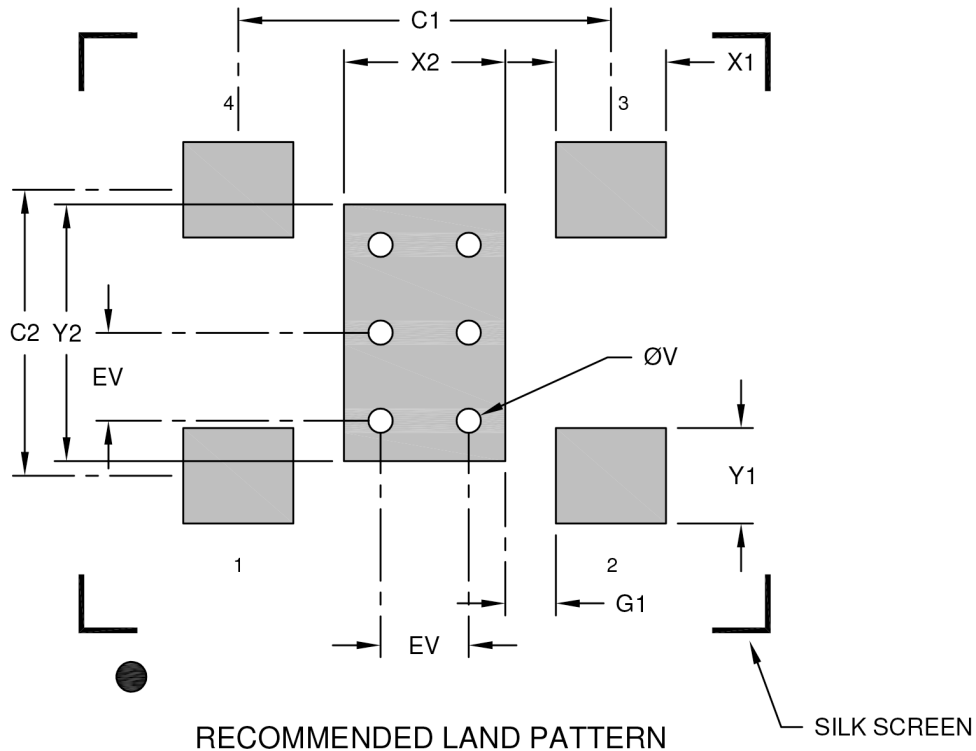

Dimension Limits	Units	MILLIMETERS		
		MIN	NOM	MAX
Optional Center Pad Width	X2			2.30
Optional Center Pad Length	Y2			3.60
Contact Pad Spacing	C1		5.08	
Contact Pad Spacing	C2		3.90	
Contact Pad Width (Xnn)	X1			1.50
Contact Pad Length (Xnn)	Y1			1.30
Contact Pad to Center Pad (Xnn)	G1	0.69		
Thermal Via Diameter	V		0.33	
Thermal Via Pitch	EV		1.20	

**Notes:**

1. Dimensioning and tolerancing per ASME Y14.5M  
BSC: Basic Dimension. Theoretically exact value shown without tolerances.
2. For best soldering results, thermal vias, if used, should be filled or tented to avoid solder loss during reflow process

Microchip Technology Drawing C04-3025 Rev A

## 4-Lead Very Thin Plastic Dual Flat, No Lead Package (H6A) - 5x3.2 mm Body [VDFN]

**Note:** For the most current package drawings, please see the Microchip Packaging Specification located at <http://www.microchip.com/packaging>

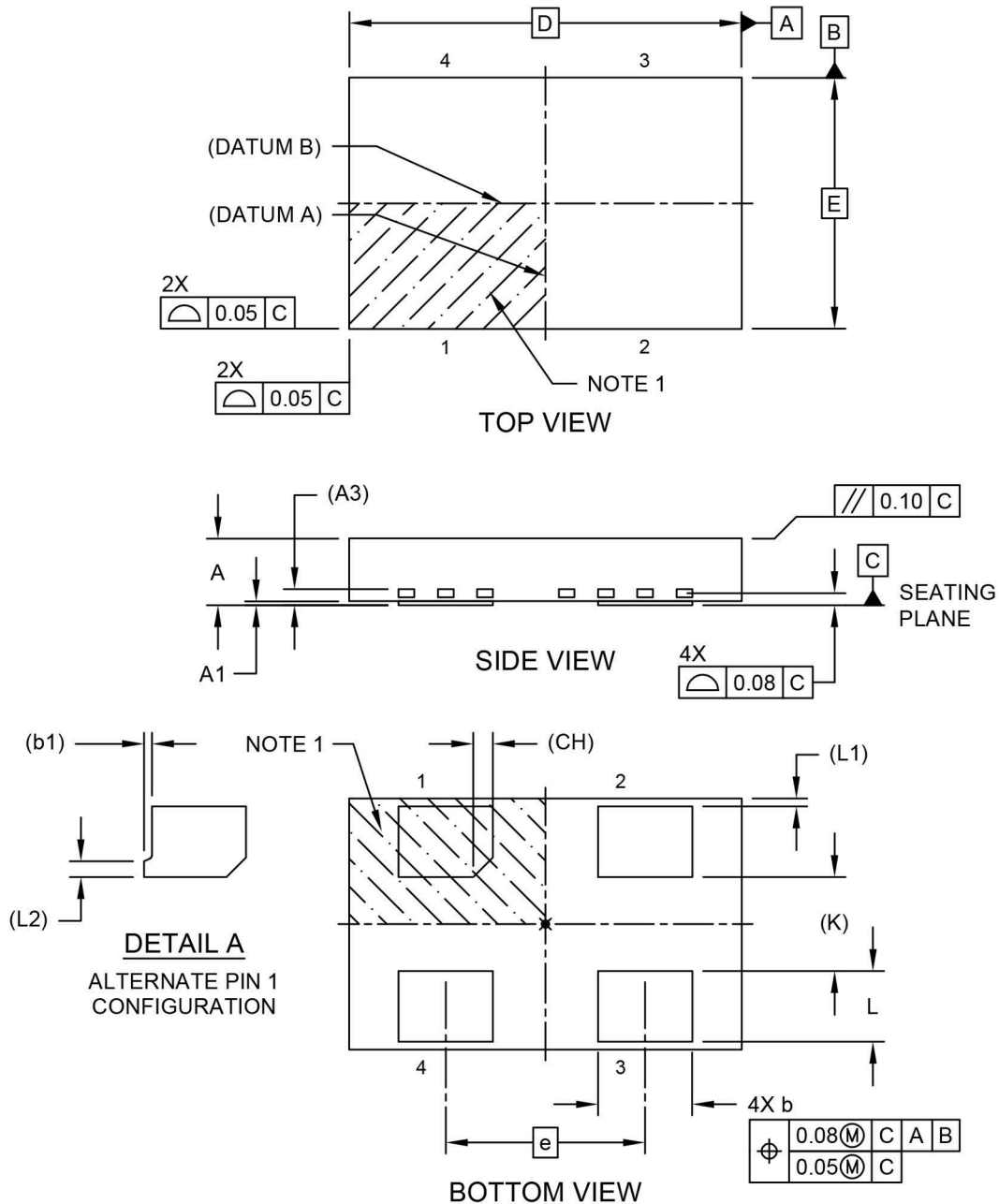

Microchip Technology Drawing C04-1008 Rev A Sheet 1 of 2

# DSC61XXB

## 4-Lead Very Thin Plastic Dual Flat, No Lead Package (H6A) - 5x3.2 mm Body [VDFN]

**Note:** For the most current package drawings, please see the Microchip Packaging Specification located at <http://www.microchip.com/packaging>

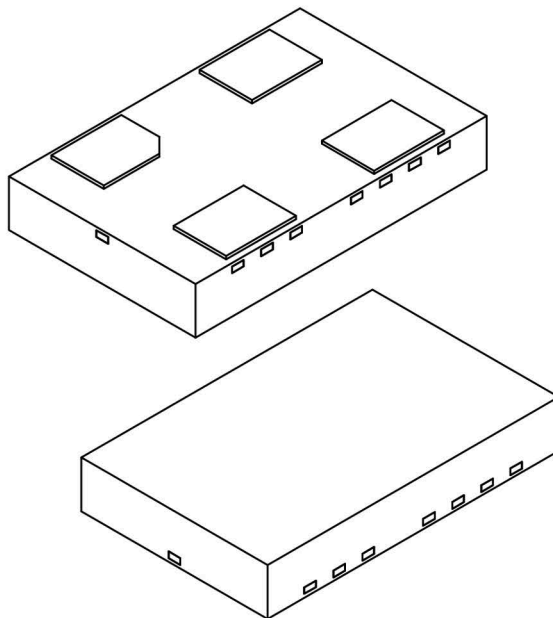

Dimension Limits	Units	MILLIMETERS		
		MIN	NOM	MAX
Number of Terminals	N	4		
Pitch	e	2.54 BSC		
Overall Height	A	0.80	0.85	0.90
Standoff	A1	0.00	0.02	0.05
Terminal Thickness	A3	0.20 REF		
Overall Length	D	5.00 BSC		
Overall Width	E	3.20 BSC		
Terminal Width	b	1.15	1.20	1.25
Terminal 1 Tab	b1	0.10 REF		
Terminal Length	L	0.80	0.90	1.00
Terminal Pull Back	L1	0.10 REF		
Terminal 1 Tab	L2	0.20 REF		
Terminal 1 Chamfer	CH	0.25 REF		
Terminal Spacing	K	1.20 REF		

**Notes:**

1. Pin 1 visual index feature may vary, but must be located within the hatched area.
2. Package is saw singulated
3. Dimensioning and tolerancing per ASME Y14.5M  
BSC: Basic Dimension. Theoretically exact value shown without tolerances.  
REF: Reference Dimension, usually without tolerance, for information purposes only.

Microchip Technology Drawing C04-1008 Rev A Sheet 2 of 2

## 4-Lead Very Thin Plastic Dual Flat, No Lead Package (H6A) - 5x3.2 mm Body [VDFN]

**Note:** For the most current package drawings, please see the Microchip Packaging Specification located at <http://www.microchip.com/packaging>

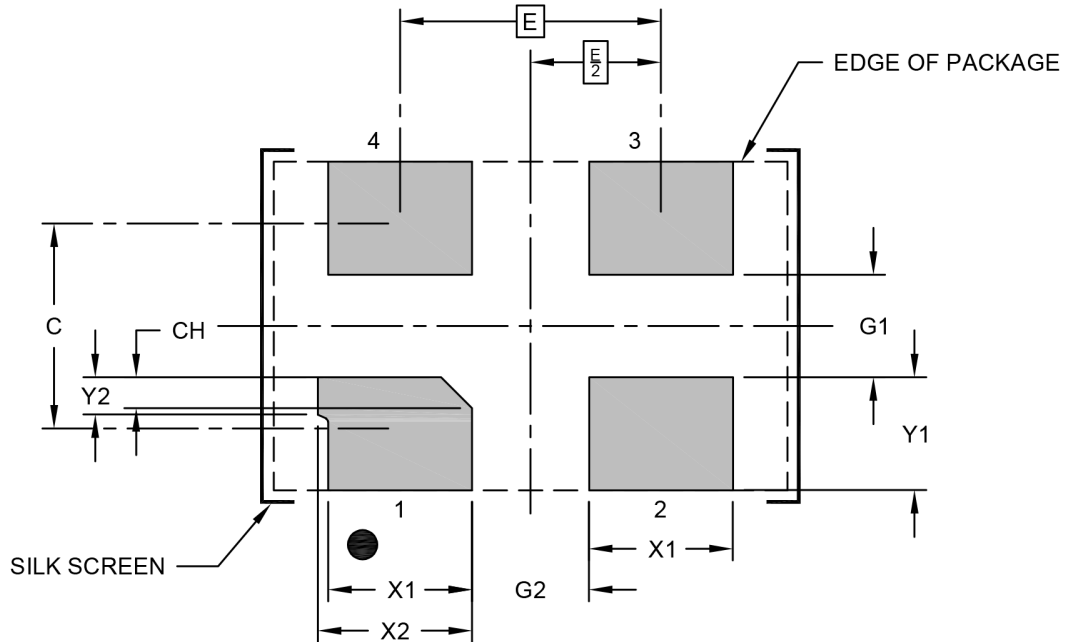

RECOMMENDED LAND PATTERN

Dimension Limits	Units	MILLIMETERS		
		MIN	NOM	MAX
Contact Pitch	E			
Contact Pad Spacing	C		2.00	
Contact Pad Width (X4)	X1			1.40
Contact Pad Width	X2			1.50
Contact Pad Length (X4)	Y1			1.10
Contact Pad Tab Length	Y2			0.36
Contact Pad to Center Pad (X2)	G1	1.00		
Contact Pad to Contact Pad (X2)	G2	1.14		
Terminal 1 Contact Pad Chamfer	CH		0.30	

Notes:

1. Dimensioning and tolerancing per ASME Y14.5M  
BSC: Basic Dimension. Theoretically exact value shown without tolerances.

Microchip Technology Drawing C04-3008 Rev A

# DSC61XXB

## 4-Lead Very Thin Plastic Dual Flatpack No-Lead (H4A) - 3.2x2.5 mm Body [VDFN]

**Note:** For the most current package drawings, please see the Microchip Packaging Specification located at <http://www.microchip.com/packaging>

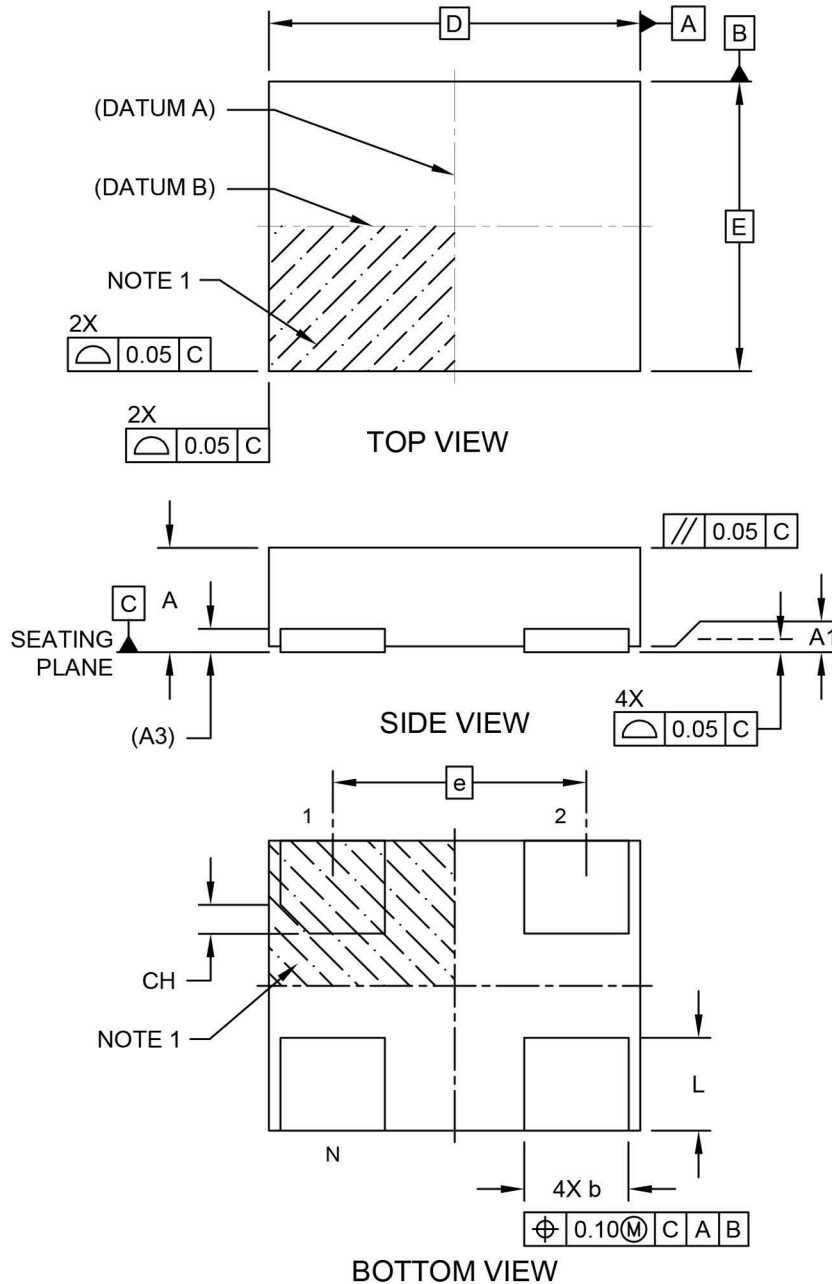

Microchip Technology Drawing C04-1006 Rev B Sheet 1 of 2

## 4-Lead Very Thin Plastic Dual Flatpack No-Lead (H4A) - 3.2x2.5 mm Body [VDFN]

**Note:** For the most current package drawings, please see the Microchip Packaging Specification located at <http://www.microchip.com/packaging>

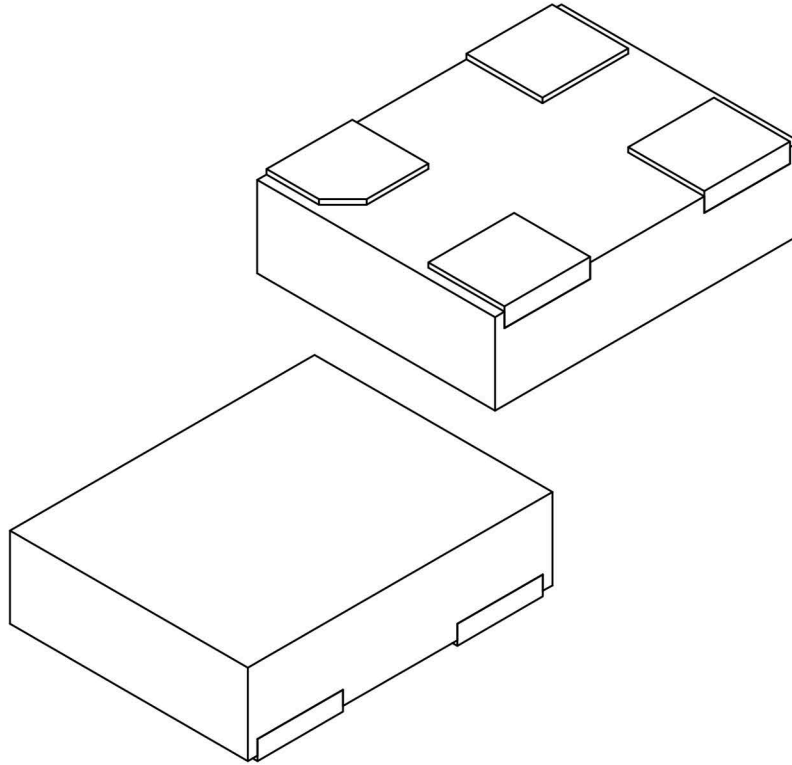

Dimension Limits	Units	MILLIMETERS		
		MIN	NOM	MAX
Number of Terminals	N	4		
Pitch	e	2.10 BSC		
Overall Height	A	0.80	0.85	0.90
Standoff	A1	0.00	0.02	0.05
Overall Length	D	3.20 BSC		
Overall Width	E	2.50 BSC		
Terminal Width	b	0.85	0.90	0.95
Terminal Length	L	0.70	0.80	0.90
Terminal 1 Index Chamfer	CH	0.25 REF		

**Notes:**

1. Pin 1 visual index feature may vary, but must be located within the hatched area.
2. Package is saw singulated
3. Dimensioning and tolerancing per ASME Y14.5M  
 BSC: Basic Dimension. Theoretically exact value shown without tolerances.  
 REF: Reference Dimension, usually without tolerance, for information purposes only.

Microchip Technology Drawing C04-1006 Rev B Sheet 2 of 2

# DSC61XXB

## 4-Lead Very Thin Plastic Dual Flatpack No-Lead (H4A) - 3.2x2.5 mm Body [VDFN]

**Note:** For the most current package drawings, please see the Microchip Packaging Specification located at <http://www.microchip.com/packaging>

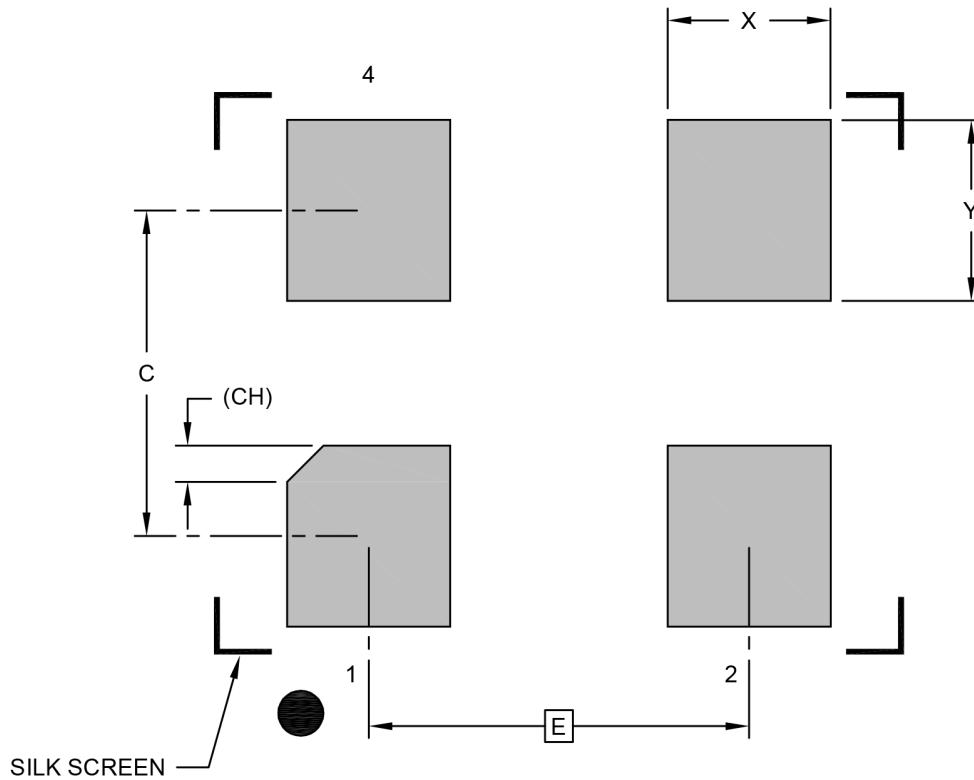

### RECOMMENDED LAND PATTERN

Dimension Limits	Units	MILLIMETERS		
		MIN	NOM	MAX
Contact Pitch	E	2.10 BSC		
Contact Pad Spacing	C		1.80	
Contact Pad Width (Xnn)	X			0.90
Contact Pad Length (Xnn)	Y			1.00
Contact Pad Length (Xnn)	CH	0.20 REF		

#### Notes:

1. Dimensioning and tolerancing per ASME Y14.5M

BSC: Basic Dimension. Theoretically exact value shown without tolerances.

REF: Reference Dimension, usually without tolerance, for information purposes only.

Microchip Technology Drawing C04-3006 Rev B

## 4-Lead Very Thin Land Grid Array (AUA) - 2.5x2.0 mm Body [VLGA]

**Note:** For the most current package drawings, please see the Microchip Packaging Specification located at <http://www.microchip.com/packaging>

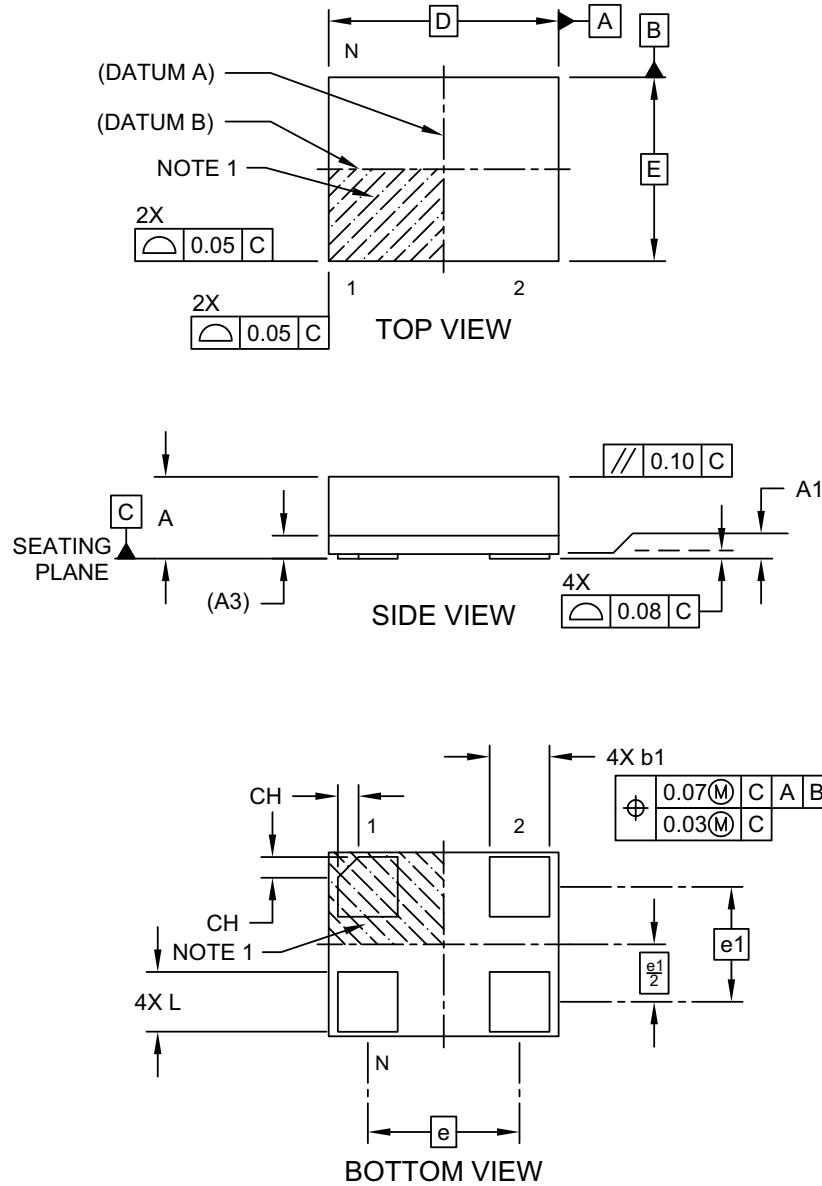

Microchip Technology Drawing C04-1202B Sheet 1 of 2

# DSC61XXB

## 4-Lead Very Thin Land Grid Array (AUA) - 2.5x2.0 mm Body [VLGA]

**Note:** For the most current package drawings, please see the Microchip Packaging Specification located at <http://www.microchip.com/packaging>

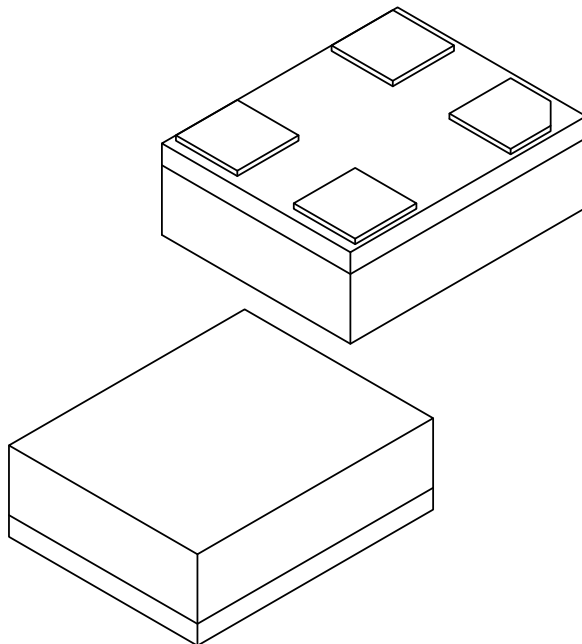

Dimension Limits	Units	MILLIMETERS		
		MIN	NOM	MAX
Number of Terminals	N	4		
Terminal Pitch	e	1.65 BSC		
Terminal Pitch	e1	1.25 BSC		
Overall Height	A	0.79	0.84	0.89
Standoff	A1	0.00	0.02	0.05
Substrate Thickness (with Terminals)	A3	0.20 REF		
Overall Length	D	2.50 BSC		
Overall Width	E	2.00 BSC		
Terminal Width	b1	0.60	0.65	0.70
Terminal Length	L	0.60	0.65	0.70
Terminal 1 Index Chamfer	CH	-	0.225	-

**Notes:**

1. Pin 1 visual index feature may vary, but must be located within the hatched area.
2. Package is saw singulated
3. Dimensioning and tolerancing per ASME Y14.5M  
BSC: Basic Dimension. Theoretically exact value shown without tolerances.  
REF: Reference Dimension, usually without tolerance, for information purposes only.

Microchip Technology Drawing C04-1202B Sheet 2 of 2

## 4-Lead Very Thin Land Grid Array (AUA) - 2.5x2.0 mm Body [VLGA]

**Note:** For the most current package drawings, please see the Microchip Packaging Specification located at <http://www.microchip.com/packaging>

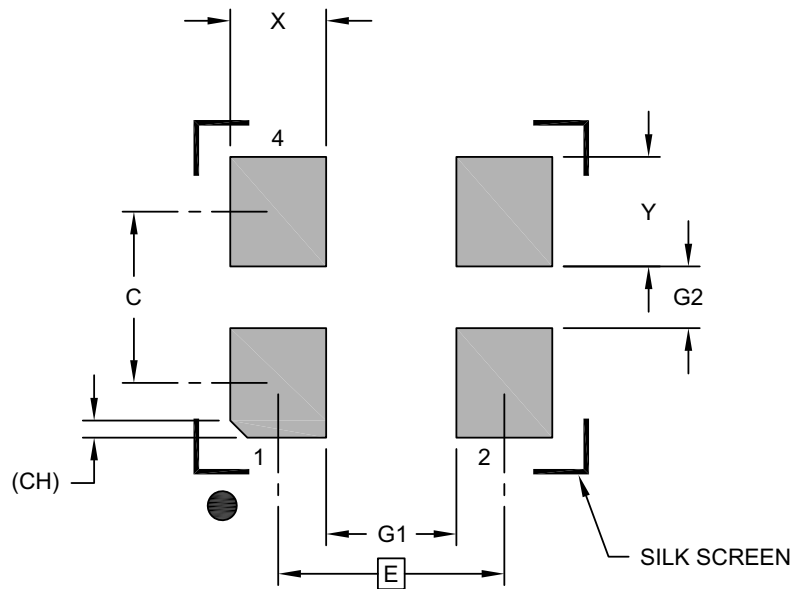

RECOMMENDED LAND PATTERN

Dimension Limits	Units	MILLIMETERS		
		MIN	NOM	MAX
Contact Pitch	E	1.65 BSC		
Contact Spacing	C		1.25	
Contact Width (X4)	X			0.70
Contact Pad Length (X4)	Y			0.80
Space Between Contacts (X2)	G1	0.95		
Space Between Contacts (X2)	G2	0.45		
Contact 1 Index Chamfer	CH	0.13 X 45° REF		

**Notes:**

1. Dimensioning and tolerancing per ASME Y14.5M

BSC: Basic Dimension. Theoretically exact value shown without tolerances.

Microchip Technology Drawing C04-3202B

# DSC61XXB

## 4-Lead Very Thin Fine Pitch Land Grid Array (ASA) - 2.0x1.6 mm Body [VFLGA]

**Note:** For the most current package drawings, please see the Microchip Packaging Specification located at <http://www.microchip.com/packaging>

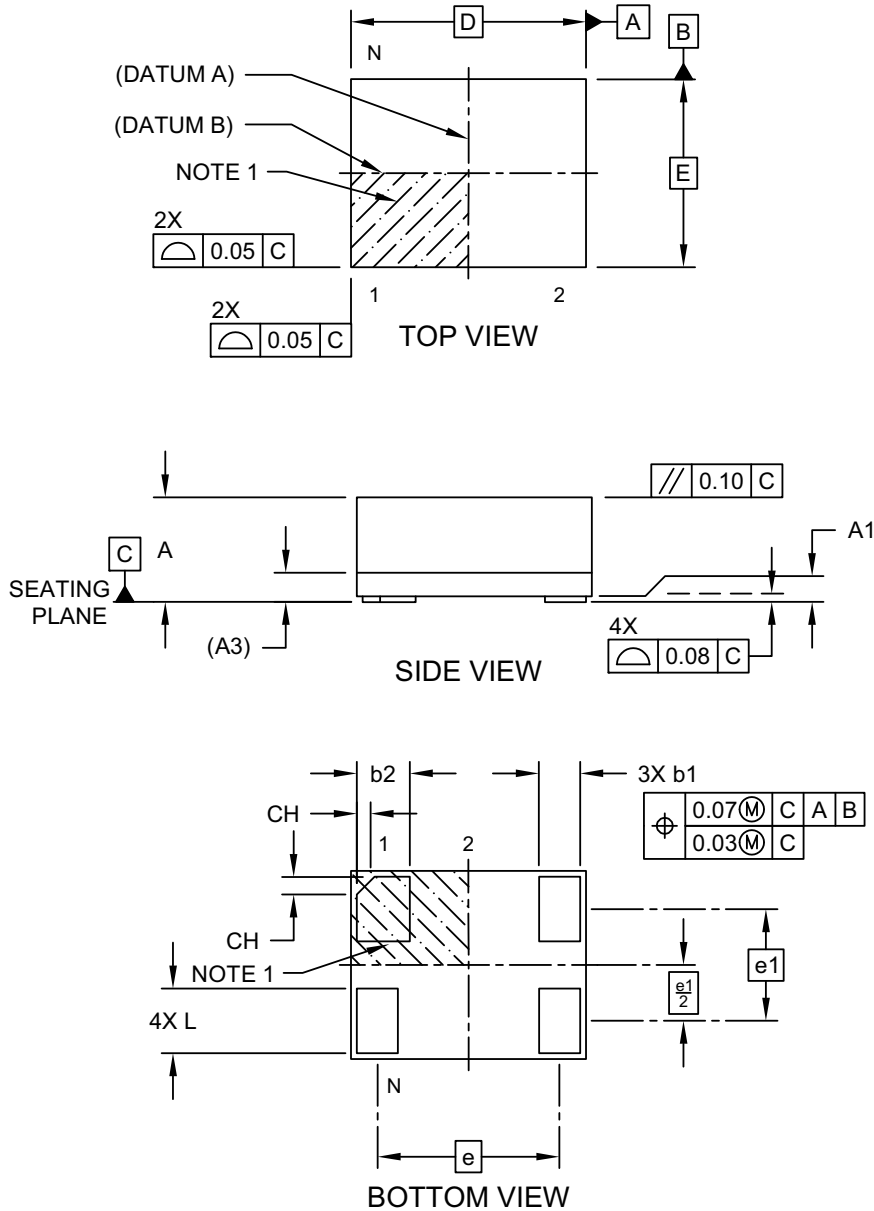

Microchip Technology Drawing C04-1200 Rev D Sheet 1 of 2

## 4-Lead Very Thin Fine Pitch Land Grid Array (ASA) - 2.0x1.6 mm Body [VFLGA]

**Note:** For the most current package drawings, please see the Microchip Packaging Specification located at <http://www.microchip.com/packaging>

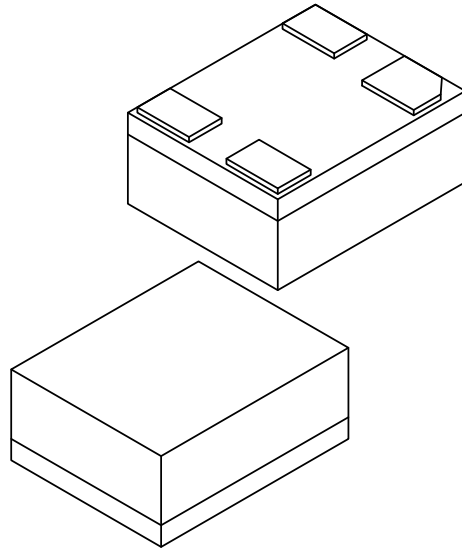

Dimension Limits	Units	MILLIMETERS		
		MIN	NOM	MAX
Number of Terminals	N	4		
Terminal Pitch	e	1.55 BSC		
Terminal Pitch	e1	0.95 BSC		
Overall Height	A	0.79	0.84	0.89
Standoff	A1	0.00	0.02	0.05
Substrate Thickness (with Terminals)	A3	0.20 REF		
Overall Length	D	2.00 BSC		
Overall Width	E	1.60 BSC		
Terminal Width	b1	0.30	0.35	0.40
Terminal Width	b2	0.40	0.45	0.50
Terminal Length	L	0.50	0.55	0.60
Terminal 1 Index Chamfer	CH	-	0.15	-

**Notes:**

1. Pin 1 visual index feature may vary, but must be located within the hatched area.
2. Package is saw singulated
3. Dimensioning and tolerancing per ASME Y14.5M

BSC: Basic Dimension. Theoretically exact value shown without tolerances.

REF: Reference Dimension, usually without tolerance, for information purposes only.

Microchip Technology Drawing C04-1200 Rev D Sheet 2 of 2

# DSC61XXB

## 4-Lead Very Thin Fine Pitch Land Grid Array (ASA) - 2.0x1.6 mm Body [VFLGA]

**Note:** For the most current package drawings, please see the Microchip Packaging Specification located at <http://www.microchip.com/packaging>

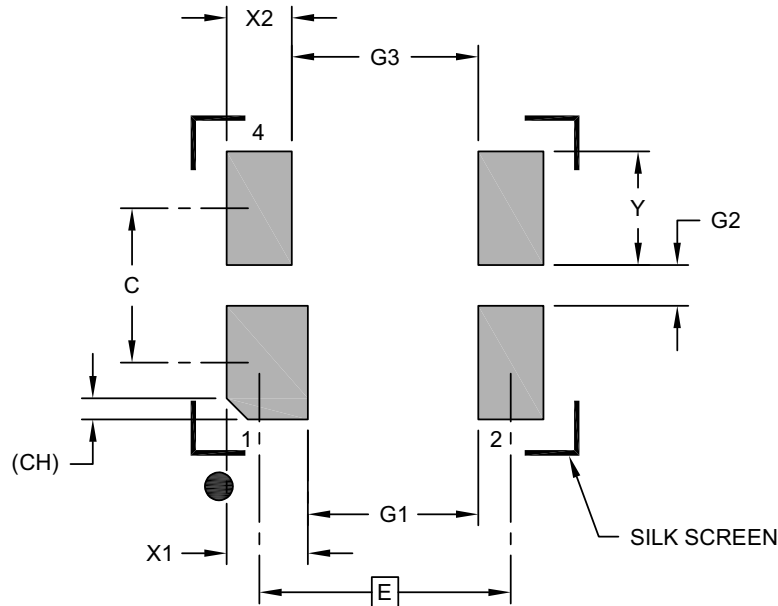

### RECOMMENDED LAND PATTERN

Dimension Limits	Units	MILLIMETERS		
		MIN	NOM	MAX
Contact Pitch	E	1.55 BSC		
Contact Spacing	C		0.95	
Contact Width	X1			0.50
Contact Width (X3)	X2			0.40
Contact Pad Length (X4)	Y			0.70
Space Between Contacts	G1	1.05		
Space Between Contacts (X2)	G2	0.25		
Space Between Contacts	G3	1.15		
Contact 1 Index Chamfer	CH	0.13 X 45° REF		

#### Notes:

- Dimensioning and tolerancing per ASME Y14.5M  
BSC: Basic Dimension. Theoretically exact value shown without tolerances.
- The value in parenthesis, next to the item description is a unit multiplier.

Microchip Technology Drawing C04-3200 Rev D

## 4-Lead Very Thin Fine Pitch Land Grid Array (ARA) - 1.6x1.2 mm Body [VFLGA]

**Note:** For the most current package drawings, please see the Microchip Packaging Specification located at <http://www.microchip.com/packaging>

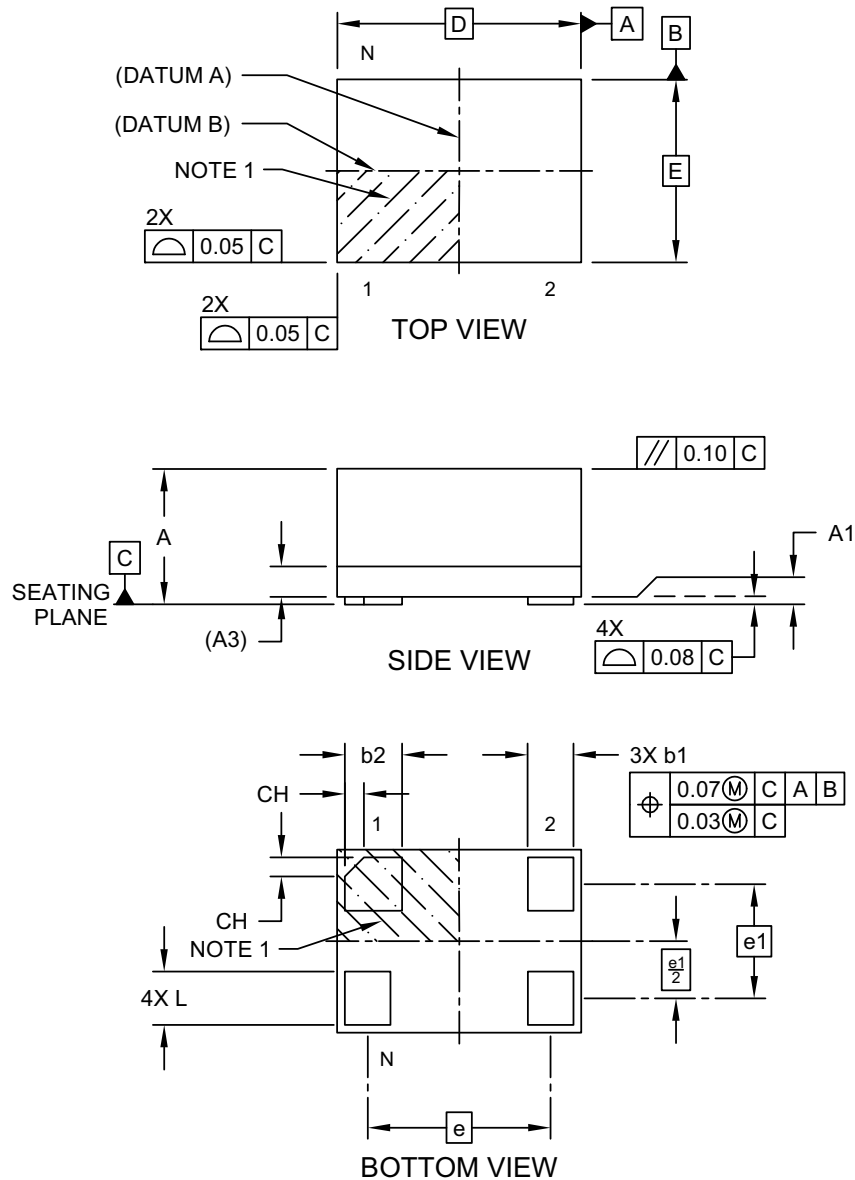

Microchip Technology Drawing C04-1199B Sheet 1 of 2

# DSC61XXB

## 4-Lead Very Thin Fine Pitch Land Grid Array (ARA) - 1.6x1.2 mm Body [VFLGA]

**Note:** For the most current package drawings, please see the Microchip Packaging Specification located at <http://www.microchip.com/packaging>

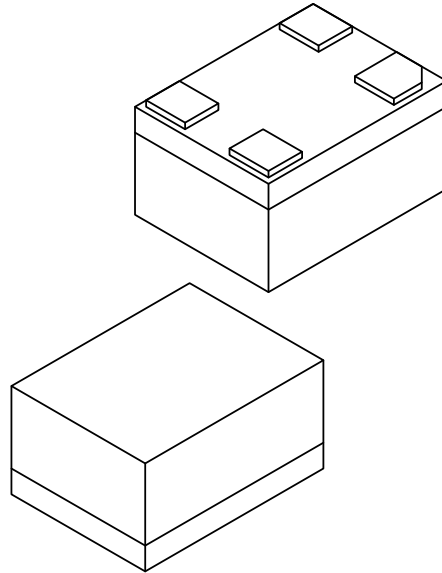

Dimension Limits	Units	MILLIMETERS		
		MIN	NOM	MAX
Number of Terminals	N	4		
Terminal Pitch	e	1.20 BSC		
Terminal Pitch	e1	0.75 BSC		
Overall Height	A	0.79	0.84	0.89
Standoff	A1	0.00	0.02	0.05
Substrate Thickness (with Terminals)	A3	0.20 REF		
Overall Length	D	1.60 BSC		
Overall Width	E	1.20 BSC		
Terminal Width	b1	0.25	0.30	0.35
Terminal Width	b2	0.325	0.375	0.425
Terminal Length	L	0.30	0.35	0.40
Terminal 1 Index Chamfer	CH	-	0.125	-

**Notes:**

1. Pin 1 visual index feature may vary, but must be located within the hatched area.
2. Package is saw singulated
3. Dimensioning and tolerancing per ASME Y14.5M

BSC: Basic Dimension. Theoretically exact value shown without tolerances.

REF: Reference Dimension, usually without tolerance, for information purposes only.

Microchip Technology Drawing C04-1199B Sheet 2 of 2

## 4-Lead Very Thin Fine Pitch Land Grid Array (ARA) - 1.6x1.2 mm Body [VFLGA]

**Note:** For the most current package drawings, please see the Microchip Packaging Specification located at <http://www.microchip.com/packaging>

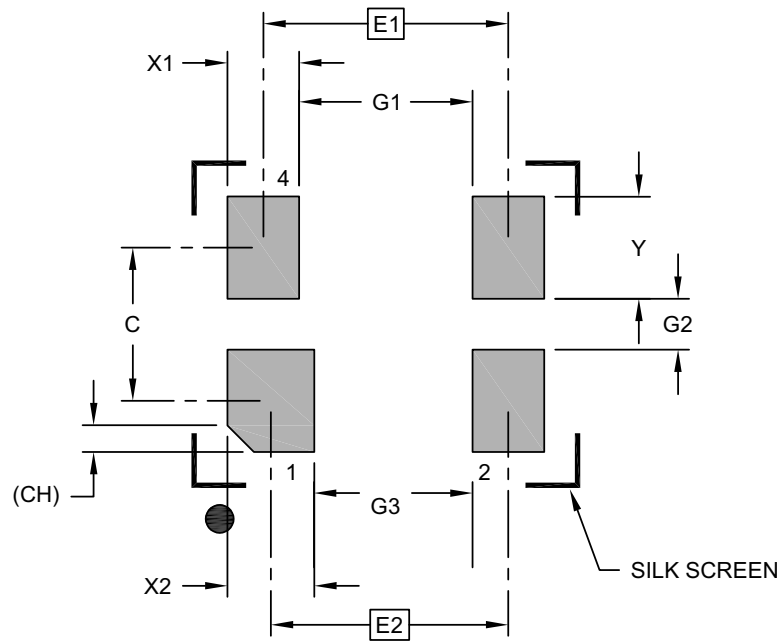

RECOMMENDED LAND PATTERN

Dimension Limits	Units	MILLIMETERS		
		MIN	NOM	MAX
Contact Pitch	E1	1.20 BSC		
Contact Pitch	E2	1.16 BSC		
Contact Spacing	C	0.75		
Contact Width (X3)	X1			0.35
Contact Width	X2			0.43
Contact Pad Length (X4)	Y			0.50
Space Between Contacts	G1	0.85		
Space Between Contacts (X2)	G2	0.25		
Space Between Contacts	G3	0.77		
Contact 1 Index Chamfer	CH	0.13 X 45° REF		

Notes:

1. Dimensioning and tolerancing per ASME Y14.5M  
BSC: Basic Dimension. Theoretically exact value shown without tolerances.
2. The value in parenthesis, next to the item description is a unit multiplier.

Microchip Technology Drawing C04-3199B

# DSC61XXB

---

NOTES:

## APPENDIX A: REVISION HISTORY

### Revision A (January 2019)

- Initial creation of DSC61xxB Microchip data sheet DS20006155A.

### Revision B (December 2021)

- Replaced all three package drawings with the most current versions.

### Revision C (November 2022)

- Added the 7.0 mm x 5.0 mm VDFN, 5.0 mm x 3.2 mm VDFN, and 3.2 mm x 2.5 mm VDFN package options throughout the document.
- Updated the previously existing package outline drawings to their most current versions.

### Revision D (March 2026)

- Added a note about bulk quantities to the [Product Identification System](#) section.

# DSC61XXB

---

NOTES:

## PRODUCT IDENTIFICATION SYSTEM

To order or obtain information, e.g., on pricing or delivery, contact your local Microchip representative or sales office.

PART NO.	X	X	X	X	X	X	X - XXX.XXXX	X
Device	Pin 1 Definition	Output Drive Strength	Package	Temperature Range	Frequency Stability	Revision	Frequency	Media Type
<b>Device:</b>	DSC61:		Ultra-Small, Ultra-Low Power MEMS Oscillator					
<b>Pin Definition:</b>	<b>Selection</b>	<b>Pin 1</b>	<b>Internal Pull-Up Register</b>					
	0	OE	Pull-up					
	1	STDBY	Pull-up					
	2	FS	Pull-up					
	4	OE	None					
	5	STDBY	None					
	6	FS	None					
<b>Output Drive Strength:</b>	1	Standard						
	2	High						
<b>Packages:</b>	A	=	4-Lead 7.0 mm x 5.0 mm VDFN					
	B	=	4-Lead 5.0 mm x 3.2 mm VDFN					
	C	=	4-Lead 3.2 mm x 2.5 mm VDFN					
	J	=	4-Lead 2.5 mm x 2.0 mm VLGA					
	M	=	4-Lead 2.0 mm x 1.6 mm VLGA					
	H	=	4-Lead 1.6 mm x 1.2 mm VFLGA					
<b>Temperature Range:</b>	A	=	-40°C to +125°C (Automotive)					
	L	=	-40°C to +105°C (Extended Industrial)					
	I	=	-40°C to +85°C (Industrial)					
	E	=	-20°C to +70°C (Extended Commercial)					
<b>Frequency Stability:</b>	1	=	± 50 ppm					
	2	=	± 25 ppm					
	3	=	± 20 ppm					
<b>Revision:</b>	B	=	Revision B					
<b>Frequency:</b>	xxx.xxxx	=	User-Defined Frequency between 001.0000 MHz and 100.0000 MHz					
	xxxxxxx	=	User-Defined Frequency between 003.500 kHz and 999.999 kHz					
	xxxx	=	Frequency configuration code when pin 1 = FS. Configure the part online through ClockWorks					
<b>Media Type:</b>	<blank>	=	Bulk					
<b>(Note 2)</b>	T	=	1,000/Reel					
	B	=	3,000/Reel					

**Examples:**

a) DSC6112JI2B-100.0000:  
Ultra-Small, Ultra-Low Power MEMS Oscillator, Pin 1 = STDBY with Internal Pull-Up, High Drive Strength, 4-Lead 2.5 mm x 2.0 mm VLGA, Industrial Temperature, ±25 ppm Stability, Revision B, 100 MHz Frequency, Bulk

b) DSC6101HE1B-016.0000T:  
Ultra-Small, Ultra-Low Power MEMS Oscillator, Pin 1 = OE with Internal Pull-Up, Standard Drive Strength, 4-Lead 1.6 mm x 1.2 mm VFLGA, Extended Commercial Temperature, ±50 ppm Stability, Revision B, 16 MHz Frequency, 1,000/Reel

c) DSC6121MI2B-005QB:  
Ultra-Small, Ultra-Low Power MEMS Oscillator, Pin 1 = Freq. Select with Internal Pull-Up, Standard Drive Strength, 4-Lead 2.0 mm x 1.6 mm VLGA, Industrial Temperature, ±25 ppm Stability, Revision B, Two Frequencies Configured through ClockWorks, 3,000/Reel

**Note 1:** Media Type identifier only appears in the catalog part number description. This identifier is used for ordering purposes and is not printed on the device package. Check with your Microchip Sales Office for package availability with different media options.

**Note 1:** Please visit Microchip ClockWorks® Configurator Website to configure the part number for customized frequency. <http://clockworks.microchip.com/timing/>.

**2:** On orders for bulk CPNs, product may be supplied in either cut tape (without a reel) or tube packaging, depending on availability. For Tape & Reel orders that are <1000 pieces, product may be supplied on cut tape (without a reel) depending on availability.

# DSC61XXB

---

---

NOTES:

---

---

## Microchip Information

### Trademarks

The “Microchip” name and logo, the “M” logo, and other names, logos, and brands are registered and unregistered trademarks of Microchip Technology Incorporated or its affiliates and/or subsidiaries in the United States and/or other countries (“Microchip Trademarks”). Information regarding Microchip Trademarks can be found at <https://www.microchip.com/en-us/about/legalinformation/microchip-trademarks>.

ISBN: 979-8-3371-3051-4

### Legal Notice

This publication and the information herein may be used only with Microchip products, including to design, test, and integrate Microchip products with your application. Use of this information in any other manner violates these terms. Information regarding device applications is provided only for your convenience and may be superseded by updates. It is your responsibility to ensure that your application meets with your specifications. Contact your local Microchip sales office for additional support or, obtain additional support at [www.microchip.com/en-us/support/design-help/client-support-services](http://www.microchip.com/en-us/support/design-help/client-support-services).

THIS INFORMATION IS PROVIDED BY MICROCHIP "AS IS". MICROCHIP MAKES NO REPRESENTATIONS OR WARRANTIES OF ANY KIND WHETHER EXPRESS OR IMPLIED, WRITTEN OR ORAL, STATUTORY OR OTHERWISE, RELATED TO THE INFORMATION INCLUDING BUT NOT LIMITED TO ANY IMPLIED WARRANTIES OF NON-INFRINGEMENT, MERCHANTABILITY, AND FITNESS FOR A PARTICULAR PURPOSE, OR WARRANTIES RELATED TO ITS CONDITION, QUALITY, OR PERFORMANCE.

IN NO EVENT WILL MICROCHIP BE LIABLE FOR ANY INDIRECT, SPECIAL, PUNITIVE, INCIDENTAL, OR CONSEQUENTIAL LOSS, DAMAGE, COST, OR EXPENSE OF ANY KIND WHATSOEVER RELATED TO THE INFORMATION OR ITS USE, HOWEVER CAUSED, EVEN IF MICROCHIP HAS BEEN ADVISED OF THE POSSIBILITY OR THE DAMAGES ARE FORESEEABLE. TO THE FULLEST EXTENT ALLOWED BY LAW, MICROCHIP'S TOTAL LIABILITY ON ALL CLAIMS IN ANY WAY RELATED TO THE INFORMATION OR ITS USE WILL NOT EXCEED THE AMOUNT OF FEES, IF ANY, THAT YOU HAVE PAID DIRECTLY TO MICROCHIP FOR THE INFORMATION.

Use of Microchip devices in life support and/or safety applications is entirely at the buyer's risk, and the buyer agrees to defend, indemnify and hold harmless Microchip from any and all damages, claims, suits, or expenses resulting from such use. No licenses are conveyed, implicitly or otherwise, under any Microchip intellectual property rights unless otherwise stated.

### Microchip Devices Code Protection Feature

Note the following details of the code protection feature on Microchip products:

- Microchip products meet the specifications contained in their particular Microchip Data Sheet.
- Microchip believes that its family of products is secure when used in the intended manner, within operating specifications, and under normal conditions.
- Microchip values and aggressively protects its intellectual property rights. Attempts to breach the code protection features of Microchip product is strictly prohibited and may violate the Digital Millennium Copyright Act.
- Neither Microchip nor any other semiconductor manufacturer can guarantee the security of its code. Code protection does not mean that we are guaranteeing the product is “unbreakable”. Code protection is constantly evolving. Microchip is committed to continuously improving the code protection features of our products.