



- Features :
 - Universal AC input / Full range
 - Adjustable output voltage and current level
 - Protections: Short circuit / Over current / Over voltage / Over temperature
 - Cooling by free air convection
 - Built-in constant current limiting circuit
 - Fully isolated plastic case with terminal block style of I/O
 - Built-in active PFC function, comply with BS EN/EN61000-3-2 class C ($\geq 75\%$ load)
 - Class 2 power unit
 - Pass LPS
 - 100% full load burn-in test
 - High reliability
 - Suitable for LED lighting and moving sign applications
 - Compliance to worldwide safety regulations for lighting
 - 2 years warranty



■ GTIN CODE

MW Search: <https://www.meanwell.com/serviceGTIN.aspx>

SPECIFICATION



MODEL	PLC-45-12	PLC-45-15	PLC-45-20	PLC-45-24	PLC-45-27	PLC-45-36	PLC-45-48	
OUTPUT	DC VOLTAGE	12V	15V	20V	24V	27V	36V	48V
	CONSTANT CURRENT REGION Note.6	9 ~ 12V	11.25 ~ 15V	15 ~ 20V	18 ~ 24V	20.25 ~ 27V	27 ~ 36V	36 ~ 48V
	RATED CURRENT	3.8A	3A	2.3A	1.9A	1.7A	1.25A	0.95A
	CURRENT RANGE	0 ~ 3.8A	0 ~ 3A	0 ~ 2.3A	0 ~ 1.9A	0 ~ 1.7A	0 ~ 1.25A	0 ~ 0.95A
	RATED POWER	45.6W	45W	46W	45.6W	45.9W	45W	45.6W
	RIPPLE & NOISE (max.) Note.2	2Vp-p	2.4Vp-p	1.8Vp-p	2.7Vp-p	2.7Vp-p	3.6Vp-p	4.6Vp-p
	VOLTAGE ADJ. RANGE Note.5	11.5 ~ 13V	14.5 ~ 16.2V	19.5 ~ 22V	24 ~ 26V	25 ~ 30V	32.5 ~ 39V	43.6 ~ 51.8V
	CURRENT ADJ. RANGE Note.5	2.85 ~ 3.914A	2.25 ~ 3.1A	1.725 ~ 2.37A	1.425 ~ 1.957A	1.275 ~ 1.75A	0.938 ~ 1.288A	0.713 ~ 0.979A
	VOLTAGE TOLERANCE Note.3	$\pm 10\%$						
	LINE REGULATION	$\pm 3.0\%$						
LOAD REGULATION	$\pm 5.0\%$							
SETUP TIME	500ms / 230VAC 1200ms / 115VAC at full load							
INPUT	VOLTAGE RANGE Note.4	90 ~ 264VAC		127 ~ 370VDC				
	FREQUENCY RANGE	47 ~ 63Hz						
	POWER FACTOR (Typ.)	PF>0.92/115VAC, PF>0.9/230VAC at full load (Please refer to "Power Factor Characteristic" curve)						
	TOTAL HARMONIC DISTORTION	THD< 20% when output loading $\geq 75\%$ at 115VAC/230VAC input						
	EFFICIENCY (Typ.)	84.5%	85%	86.5%	86.5%	86.5%	87.5%	87.5%
	AC CURRENT (Typ.)	0.55A/115VAC		0.25A/230VAC				
	INRUSH CURRENT (Typ.)	COLD START 35A(twidth=50 μ s measured at 50% Ipeak) at 230VAC						
	MAX. No. of PSUs on 16A CIRCUIT BREAKER	42 units (circuit breaker of type B) / 42 units (circuit breaker of type C) at 230VAC						
LEAKAGE CURRENT	<0.75mA / 240VAC							
PROTECTION	OVER CURRENT	95 ~ 110% Protection type : Constant current limiting, recovers automatically after fault condition is removed						
	SHORT CIRCUIT	Hiccup mode, recovers automatically after fault condition is removed.						
	OVER VOLTAGE	13.8 ~ 16V	17.5 ~ 21V	22.8 ~ 25V	28 ~ 32V	31 ~ 35V	41 ~ 46V	54 ~ 60V
	OVER TEMPERATURE	Shut down o/p voltage, recovers automatically after temperature goes down						
ENVIRONMENT	WORKING TEMP.	-30 ~ +50 $^{\circ}$ C (Refer to "Derating Curve")						
	WORKING HUMIDITY	20 ~ 95% RH non-condensing						
	STORAGE TEMP., HUMIDITY	-40 ~ +80 $^{\circ}$ C, 10 ~ 95% RH						
	TEMP. COEFFICIENT	$\pm 0.03\%/^{\circ}$ C (0 ~ 50 $^{\circ}$ C)						
SAFETY & EMC	VIBRATION	10 ~ 500Hz, 2G 12min./1cycle, period for 72min. each along X, Y, Z axes						
	SAFETY STANDARDS	UI1310, TUV BS EN/EN61347-1, BS EN/EN61347-2-13, CAN/CSA C22.2 No. 223-M91(except for 48V), EAC TP TC 004 approved						
	WITHSTAND VOLTAGE	I/P-O/P:3.75KVAC		I/P-FG:2KVAC		O/P-FG:0.5KVAC		
	ISOLATION RESISTANCE	I/P-O/P:100M Ohms / 500VDC / 25 $^{\circ}$ C / 70% RH						
EMC	EMC EMISSION	Compliance to BS EN/EN55015, BS EN/EN61000-3-2 Class C ($\geq 75\%$ load) ; BS EN/EN61000-3-3, EAC TP TC 020						
	EMC IMMUNITY	Compliance to BS EN/EN61000-4-2,3,4,5,6,8,11, BS EN/EN55024, BS EN/EN61547, light industry level, EAC TP TC 020						
OTHERS	MTBF	3444.5K hrs min. Telcordia SR-332 (Bellcore)		417.1Khrs min.		MIL-HDBK-217F (25 $^{\circ}$ C)		
	DIMENSION	181.5*62*35mm (L*W*H)						
	PACKING	0.41Kg; 30pcs/13.3Kg/0.67CUFT						
NOTE	1. All parameters NOT specially mentioned are measured at 230VAC input, rated load and 25 $^{\circ}$ C of ambient temperature. 2. Ripple & noise are measured at 20MHz of bandwidth by using a 12" twisted pair-wire terminated with a 0.1 μ f & 47 μ f parallel capacitor. 3. Tolerance : includes set up tolerance, line regulation and load regulation. 4. Derating may be needed under low input voltage. Please check the static characteristics for more details. 5. Output voltage can be adjusted through the SVR1 on the PCB ; limit of output constant current level can be adjusted through the SVR2 on the PCB. 6. Please refer to "DRIVING METHODS OF LED MODULE". 7. The power supply is considered as a component that will be operated in combination with final equipment. Since EMC performance will be affected by the complete installation, the final equipment manufacturers must re-qualify EMC Directive on the complete installation again. (as available on https://www.meanwell.com/Upload/PDF/EML_statement_en.pdf) 8. Direct connecting to LEDs is suggested, but is not suitable for using additional drivers. 9. To fulfill requirements of the latest ErP regulation for lighting fixtures, this LED power supply can only be used behind a switch without permanently connected to the mains. 10. The ambient temperature derating of 3.5 $^{\circ}$ C/1000m with fanless models and of 5 $^{\circ}$ C/1000m with fan models for operating altitude higher than 2000m(6500ft). 11. This product is not suitable for LED lighting applications in China.(It is recommended to use the LPF/NPF/XLG/XLC/XLN series in China) ※ Product Liability Disclaimer : For detailed information, please refer to https://www.meanwell.com/serviceDisclaimer.aspx							

■ Mechanical Specification

Case No.991A Unit:mm Tolerance:±1

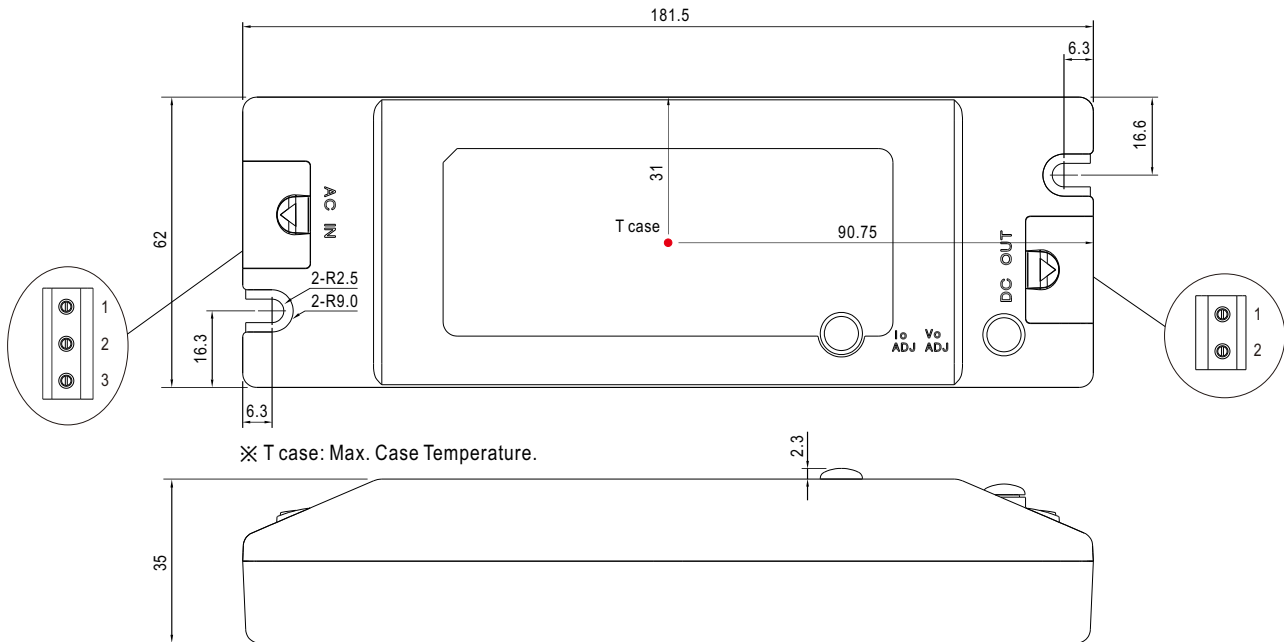

■ Block Diagram

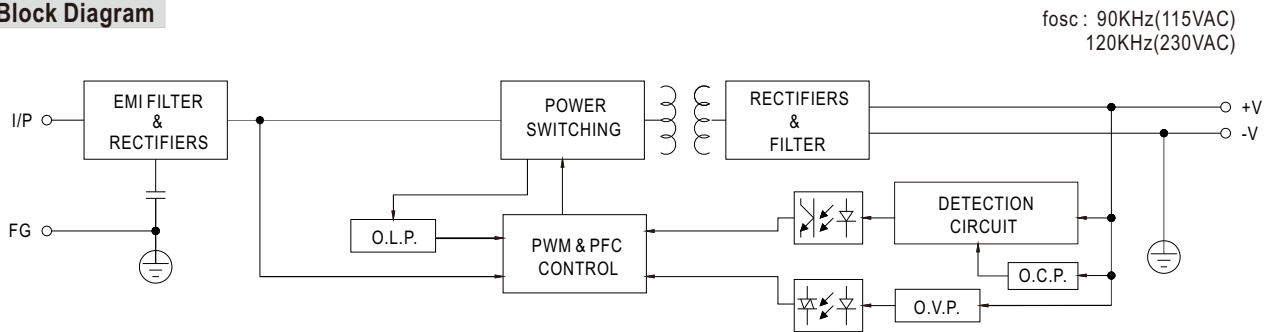

■ Derating Curve

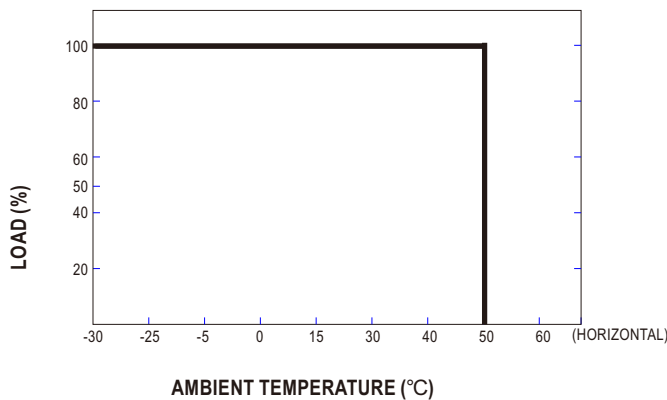

■ Static Characteristics

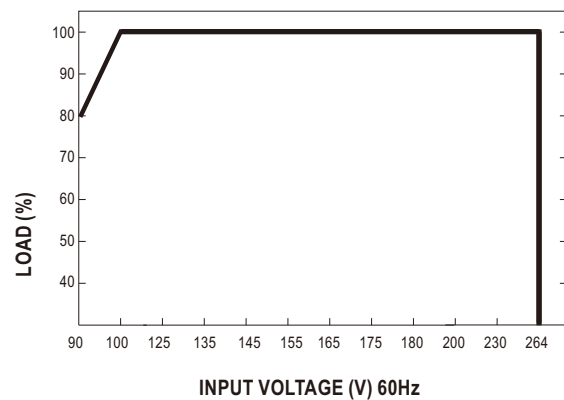

Power Factor Characteristic

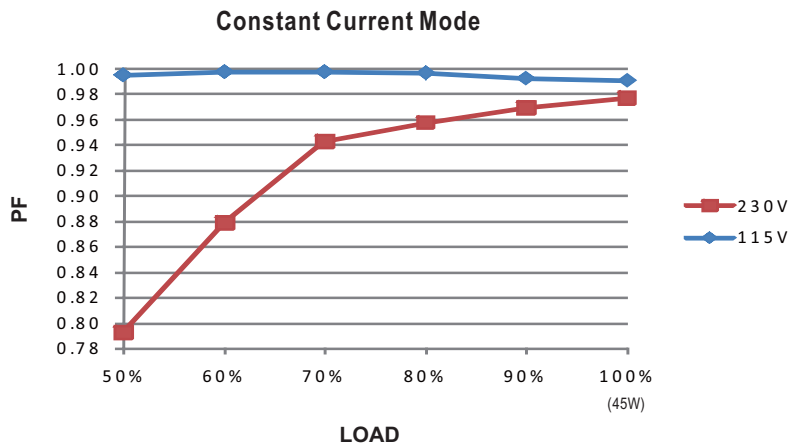

EFFICIENCY vs LOAD (48V Model)

PLC-45 series possess superior working efficiency that up to 87.5% can be reached in field applications.

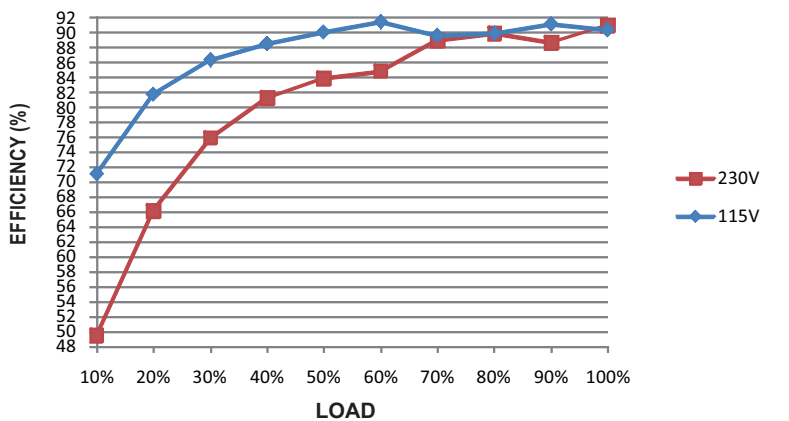

DRIVING METHODS OF LED MODULE

This LED power supply is suggested to work in constant current mode area (CC) to drive the LEDs.

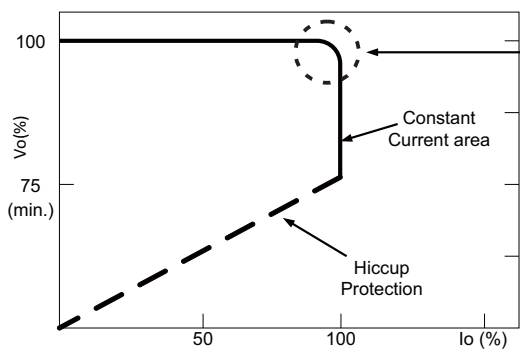

Typical LED power supply I-V curve

In the constant current region, the highest voltage at the output of the driver depends on the configuration of the end systems.
Should there be any compatibility issues, please contact MEAN WELL.