

G4E160-AB01-01

AC centrifugal fan

forward curved, single inlet

with housing (flange)

ebm-papst Mulfingen GmbH & Co. KG

Bachmühle 2 · D-74673 Mulfingen

Phone +49 7938 81-0

Fax +49 7938 81-110

info1@de.ebmpapst.com

www.ebmpapst.com

Limited partnership · Headquarters Mulfingen

County court Stuttgart · HRA 590344

General partner Elektrobau Mulfingen GmbH · Headquarters Mulfingen

County court Stuttgart · HRB 590142

Nominal data

Type	G4E160-AB01-01		
Motor	M4E068-CF		
Phase		1~	1~
Nominal voltage	VAC	230	230
Frequency	Hz	50	60
Type of data definition		fa	fa
Valid for approval / standard		CE	CE
Speed	min ⁻¹	1300	1400
Power input	W	67	90
Current draw	A	0.3	0.4
Motor capacitor	µF	2	2
Capacitor voltage	VDB	450	450
Capacitor standard		P0 (CE)	P0 (CE)
Min. back pressure	Pa	0	0
Max. ambient temperature	°C	65	60
Starting current	A	0.46	0.46

ml = max. load · me = max. efficiency · fa = running at free air · cs = customer specs · cu = customer unit
Subject to alterations



G4E160-AB01-01

AC centrifugal fan

forward curved, single inlet

with housing (flange)

Technical features

Mass	2.9 kg
Size	160 mm
Surface of rotor	Partially cast in aluminium
Material of impeller	Sheet steel, hot-dip galvanised
Housing material	Die-cast aluminium
Direction of rotation	Clockwise, seen on rotor
Type of protection	IP 44
Insulation class	"B"
Humidity class	F0
Max. permissible ambient motor temp. (transp./ storage)	+ 80 °C
Min. permissible ambient motor temp. (transp./storage)	- 40 °C
Mounting position	Any
Condensate discharge holes	None
Operation mode	S1
Motor bearing	Ball bearing
Touch current acc. IEC 60990 (measuring network Fig. 4, TN system)	< 0.75 mA
Motor protection	Thermal overload protector (TOP) wired internally
Protection class	I (if protective earth is connected by customer)
Product conforming to standard	EN 60335-1; CE
Approval	CCC



AC centrifugal fan

forward curved, single inlet
with housing (flange)

Product drawing

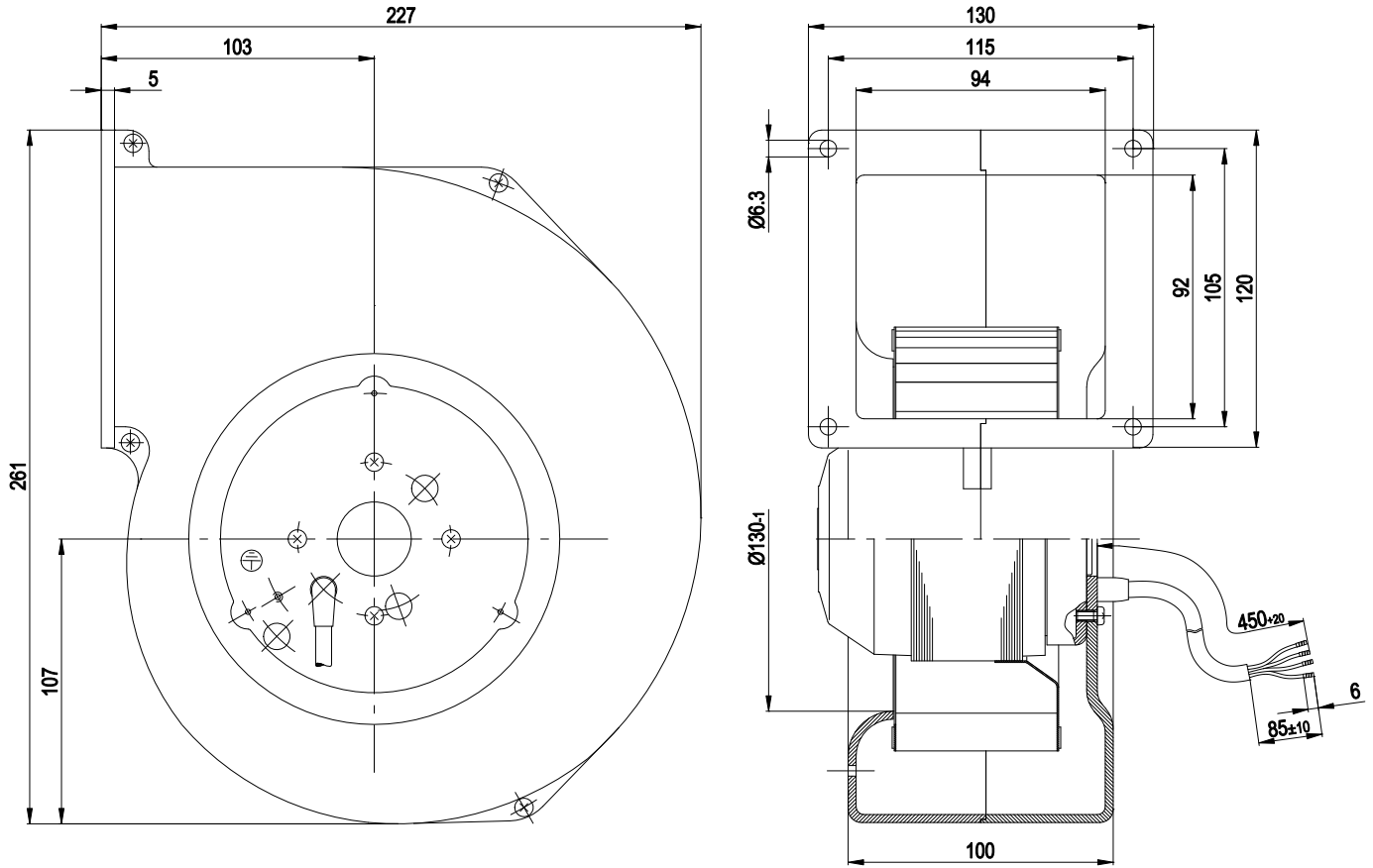

1 Connection line PVC, 4x brass lead tips crimped

Connection screen

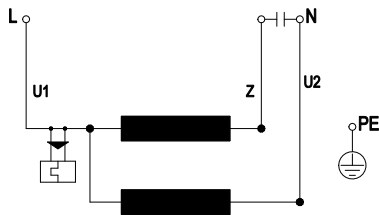

U1	blue	Z	brown	U2	black
PE	green/yellow				



AC centrifugal fan

forward curved, single inlet
with housing (flange)

Charts: Air flow 50 Hz

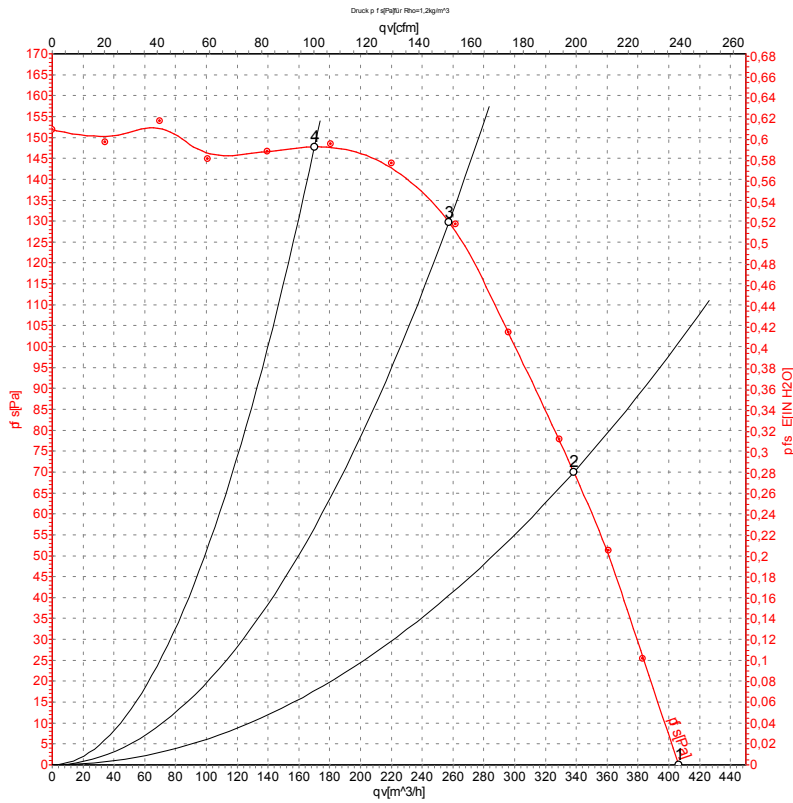

Measurement: LU-104969

Air performance measured as per ISO 5801 Installation category A. For detailed information on the measuring set-up, please contact ebm-papst. Suction-side noise levels: L_{wA} measured as per ISO 13347 / L_{pA} measured with 1m distance to fan axis. The values given are valid under the measuring conditions mentioned above and may vary according to the actual installation situation. With any deviation from the standard set-up, the specific values have to be checked and reviewed with the unit installed.

Measured values

	U	f	n	P _e	I	qv	P _{fs}
	V	Hz	min ⁻¹	W	A	m³/h	Pa
1	230	50	1300	67	0.30	410	0
2	230	50	1345	60	0.26	340	70
3	230	50	1385	56	0.24	255	130
4	230	50	1420	51	0.23	170	148

U = Supply voltage · f = Frequency · n = Speed · P_e = Power input · I = Current draw · qv = Air flow · P_{fs} = Pressure increase



AC centrifugal fan

forward curved, single inlet
with housing (flange)

Charts: Air flow 60 Hz

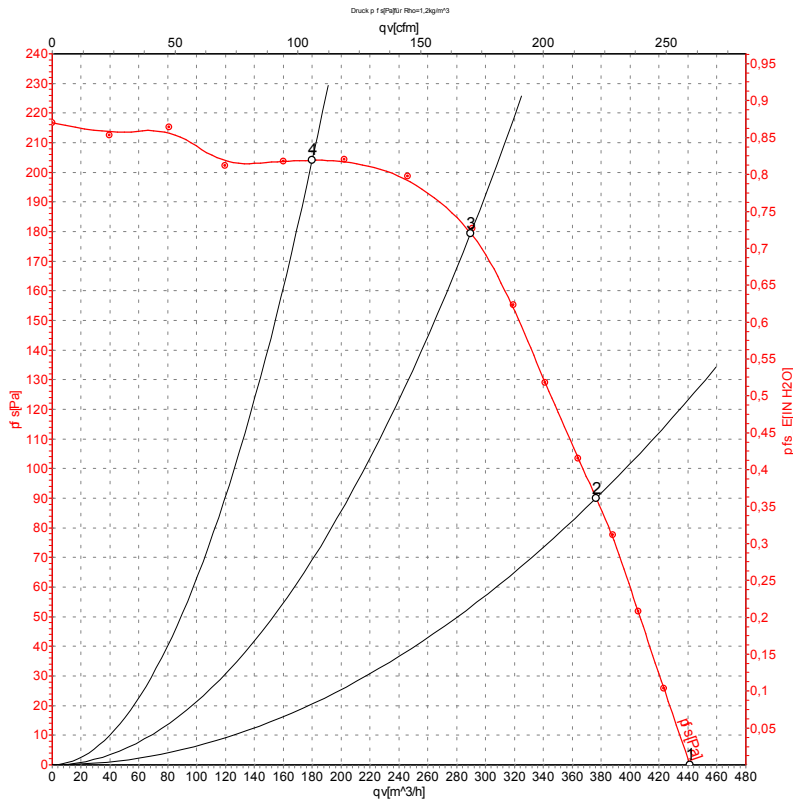

Measurement: LU-104970

Air performance measured as per ISO 5801 Installation category A. For detailed information on the measuring set-up, please contact ebm-papst. Suction-side noise levels: L_{wA} measured as per ISO 13347 / L_{pA} measured with 1m distance to fan axis. The values given are valid under the measuring conditions mentioned above and may vary according to the actual installation situation. With any deviation from the standard set-up, the specific values have to be checked and reviewed with the unit installed.

Measured values

	U	f	n	P _e	I	q _v	P _{fs}
	V	Hz	min ⁻¹	W	A	m ³ /h	Pa
1	230	60	1400	90	0.40	445	0
2	230	60	1510	82	0.36	375	90
3	230	60	1595	76	0.34	290	180
4	230	60	1660	70	0.31	180	205

U = Supply voltage · f = Frequency · n = Speed · P_e = Power input · I = Current draw · q_v = Air flow · P_{fs} = Pressure increase

