

N-Channel Logic Level Enhancement Mode Field Effect Transistor

BSS138W

Description

These N-Channel Enhancement Mode Field Effect Transistor. These products have been Designed to minimize on-state resistance while provide rugged, reliable, and fast switching performance.

These products are particularly suited for low voltage, low current applications such as small servo motor control, power MOSFET gate drivers, and other switching applications.

Features

- $R_{DS(on)} = 3.5 \Omega @ V_{GS} = 10 V, I_D = 0.22 A$
 $R_{DS(on)} = 6.0 \Omega @ V_{GS} = 4.5 V, I_D = 0.22 A$
- High Density Cell Design For Extremely Low $R_{DS(on)}$
- Rugged and Reliable
- Compact Industry Standard SOT-323 Surface Mount Package
- These Devices are Pb-Free and Halide Free

ABSOLUTE MAXIMUM RATINGS $T_A = 25^\circ C$ unless otherwise noted

Symbol	Parameter	Value	Unit
V_{DSS}	Drain to Source Voltage	50	V
V_{GSS}	Gate to Source Voltage	± 20	V
I_D	Drain Current - Continuous (Note 1) - Pulsed	0.21 0.84	A
T_J, T_{STG}	Operating and Storage Junction Temperature Range	-55 to +150	$^\circ C$
T_L	Maximum Lead Temperature for Soldering Purposes, 1/16" from Case for 10 Seconds	300	$^\circ C$

Stresses exceeding those listed in the Maximum Ratings table may damage the device. If any of these limits are exceeded, device functionality should not be assumed, damage may occur and reliability may be affected.



SOT-323, 3 Lead, 1.25X2
CASE 419AB

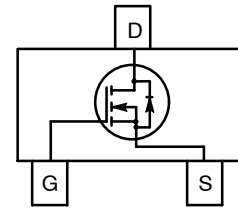

MARKING DIAGRAM

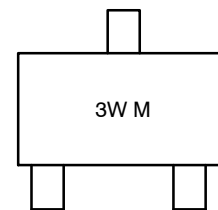

3W = Device Code
M = Date Code

ORDERING INFORMATION

Device	Package	Shipping [†]
BSS138W	SOT-323 (Pb-Free)	3000 / Tape & Reel

[†]For information on tape and reel specifications, including part orientation and tape sizes, please refer to our Tape and Reel Packaging Specifications Brochure, [BRD8011/D](#).

BSS138W

THERMAL CHARACTERISTICS

Symbol	Parameter	Value	Unit
P _D	Maximum Power Dissipation Derate Above 25°C (Note 1)	340	mW
		2.72	mW/°C
R _{θJA}	Thermal Resistance, Junction to Ambient (Note 1)	367	°C/W

ELECTRICAL CHARACTERISTICS T_A = 25°C unless otherwise noted

Symbol	Parameter	Test Conditions	Min	Typ	Max	Unit
--------	-----------	-----------------	-----	-----	-----	------

Off Characteristics

BV _{DSS}	Drain to Source Breakdown Voltage	V _{GS} = 0 V, I _D = 250 μA	50	–	–	V
$\frac{\Delta BV_{DSS(th)}}{\Delta T_J}$	Breakdown Voltage Temperature Coefficient	I _D = 250 μA, Referenced to 25°C	–	71	–	mV/°C
I _{DSS}	Zero Gate Voltage Drain Current	V _{DS} = 50 V, V _{GS} = 0 V V _{DS} = 50 V, V _{GS} = 0 V, T _J = 125°C V _{DS} = 30 V, V _{GS} = 0 V	–	–	0.5 5 100	μA μA nA
I _{GSS}	Gate–Body Leakage	V _{GS} = ±20 V, V _{DS} = 0 V	–	–	±100	nA

On Characteristics (Note2)

V _{GS(th)}	Gate to Threshold Voltage	V _{DS} = V _{GS} , I _D = 1 mA	0.8	1.3	1.5	V
$\frac{\Delta V_{GS(th)}}{\Delta T_J}$	Gate to Threshold Voltage Temperature Coefficient	I _D = 1 mA, Referenced to 25°C	–	–3.9	–	mV/°C
R _{DS(on)}	Static Drain–Source On–Resistance	V _{GS} = 10 V, I _D = 0.22 A V _{GS} = 4.5 V, I _D = 0.22 A V _{GS} = 10 V, I _D = 0.22 A, T _J = 125°C	–	1.17 1.36 2.16	3.5 6.0 5.8	Ω Ω Ω
I _{D(on)}	On–State Drain Current	V _{GS} = 10 V, V _{DS} = 5 V	0.2	–	–	A
g _{FS}	Forward Transconductance	V _{DS} = 10 V, I _D = 0.22 A	0.12	–	–	S

Dynamic Characteristics

C _{ISS}	Input Capacitance	V _{DS} = 25 V, V _{GS} = 0 V, f = 1.0 MHz	–	38	–	pF
C _{OSS}	Output Capacitance		–	5.9	–	pF
C _{RSS}	Reverse Transfer Capacitance		–	3.5	–	pF
R _g	Gate Resistance	V _{GS} = 15 mV, f = 1.0 MHz	–	11	–	Ω

Switching Characteristics

t _{d(on)}	Turn–On Delay Time	V _{DD} = 30 V, I _D = 0.29 A, V _{GS} = 10 V, R _{GEN} = 6 Ω	–	2.3	5	ns
t _r	Turn–On Rise Time		–	1.9	18	ns
t _{d(off)}	Turn–Off Delay Time		–	6.7	36	ns
t _f	Turn–Off Fall Time		–	6.5	14	ns
Q _g	Total Gate Change	V _{DS} = 25 V, I _D = 0.22 A, V _{GS} = 10 V	–	1.1	–	nC
Q _{gs}	Gate–Source Change		–	0.12	–	nC
Q _{gd}	Gate–Drain Change		–	0.22	–	nC

Drain–Source Diode Characteristics

I _S	Maximum Continuous Drain–Source Diode Forward Current	–	–	0.22	A	
V _{SD}	Drain–Source Diode Forward Voltage	V _{GS} = 0 V, I _S = 0.44 A (Note 2)	–	–	1.4	V

Product parametric performance is indicated in the Electrical Characteristics for the listed test conditions, unless otherwise noted. Product performance may not be indicated by the Electrical Characteristics if operated under different conditions.

- 367°C/W When Mounted on a minimum pad.
- Pulse Test: Pulse Width ≤ 300 μs, Duty Cycle ≤ 2.0%

TYPICAL CHARACTERISTICS

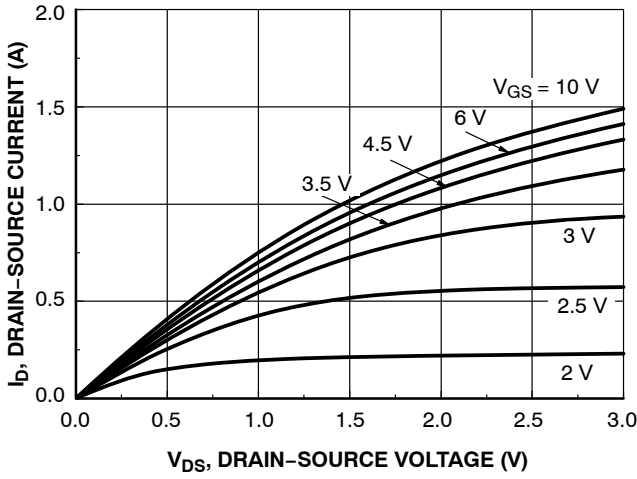

Figure 1. On-Region Characteristics

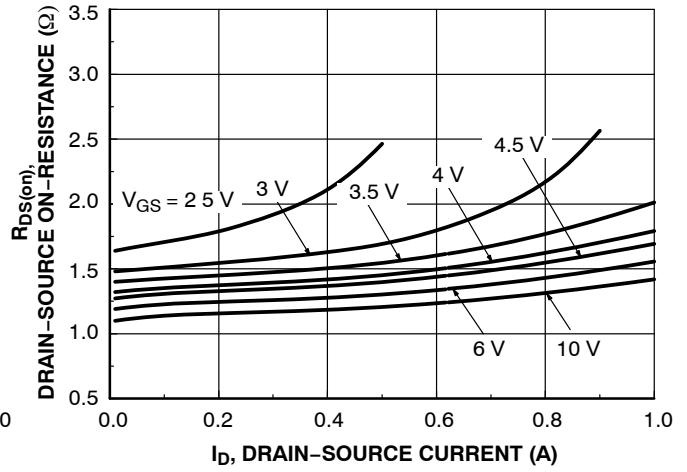

Figure 2. On-Resistance Variation With Drain Current and Gate Voltage

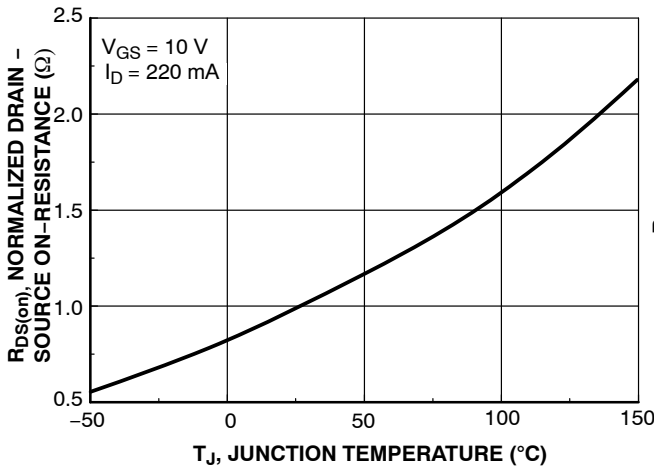

Figure 3. On-Resistance Variation with Temperature.

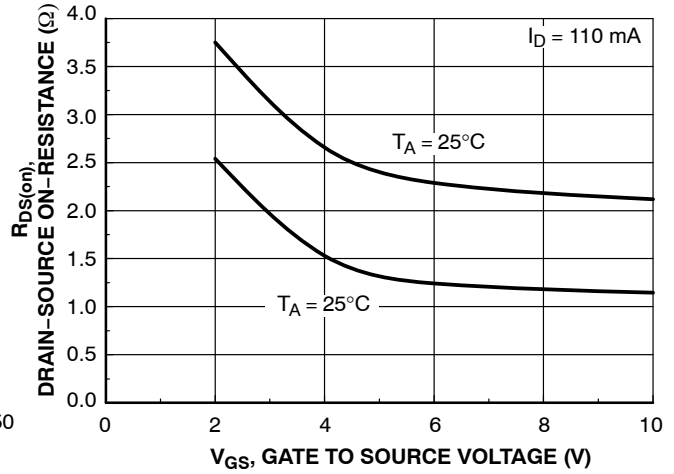

Figure 4. On-Resistance Variation with Gate-to-Source Voltage

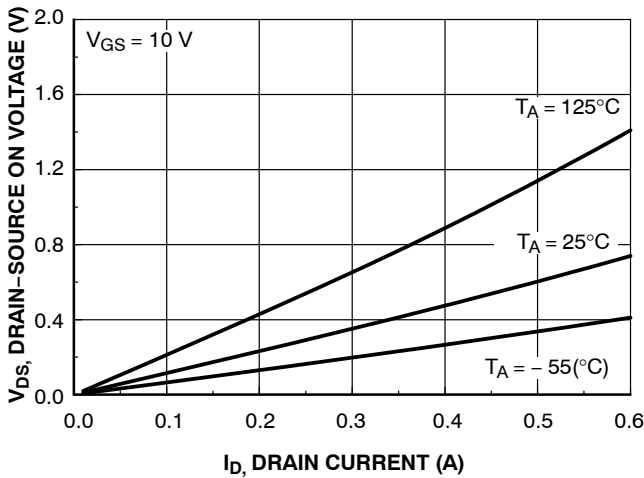

Figure 5. Drain-Source On Voltage with Temperature.

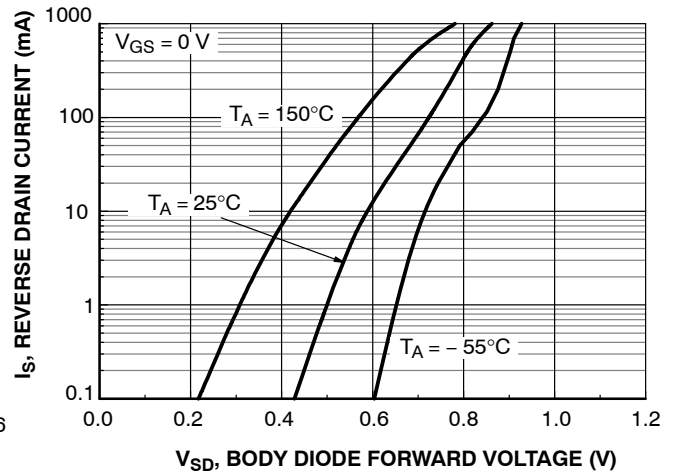

Figure 6. Body Diode Forward Voltage Variation with Source Current and Temperature

TYPICAL CHARACTERISTICS (continued)

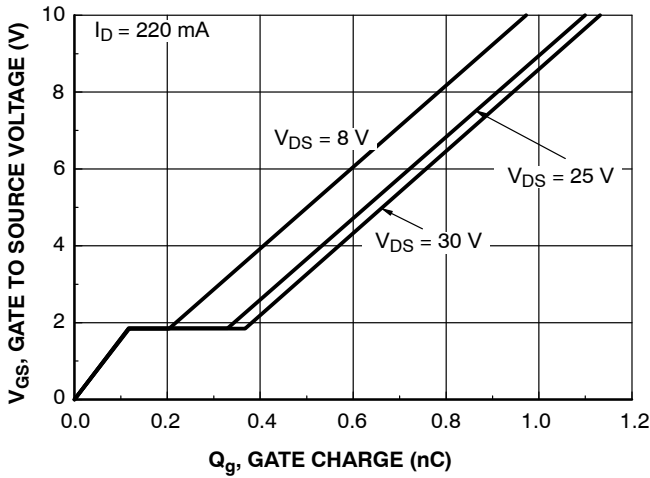

Figure 7. Gate Charge Characteristics

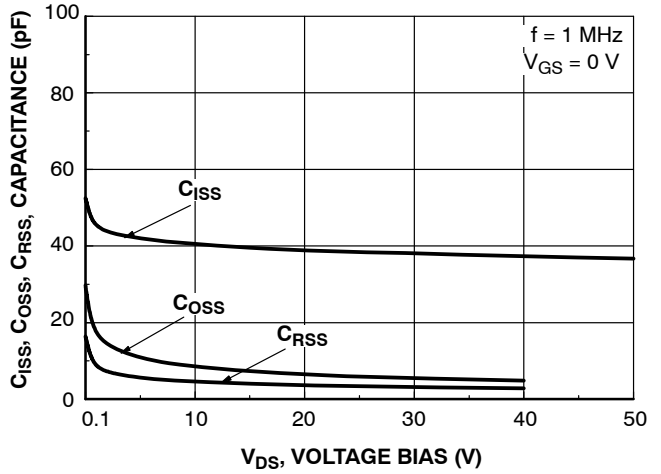

Figure 8. Capacitance Characteristics

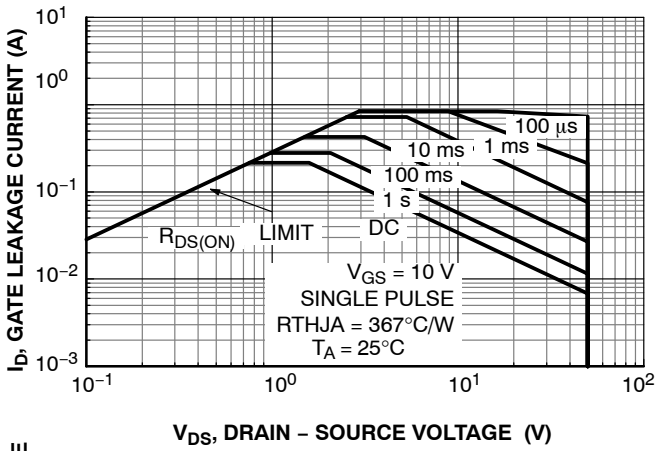

Figure 9. Maximum Safe Operating Area

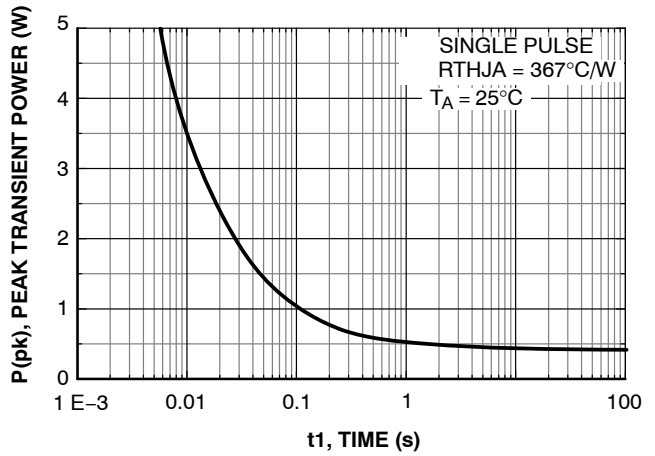

Figure 10. Single Pulse Maximum Power Dissipation

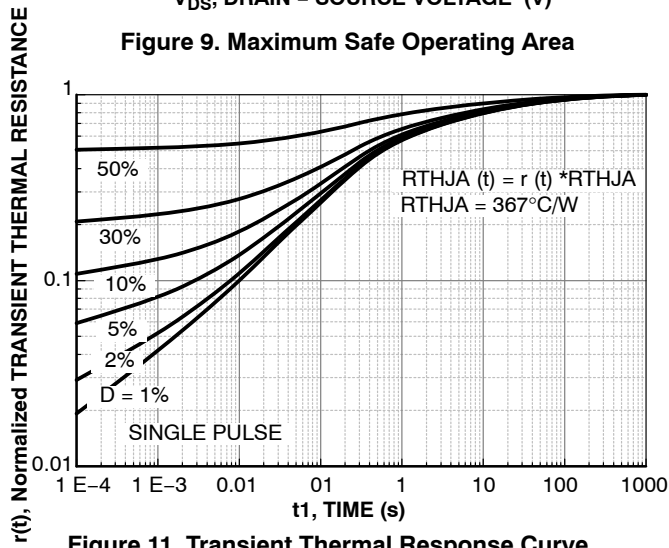
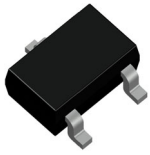
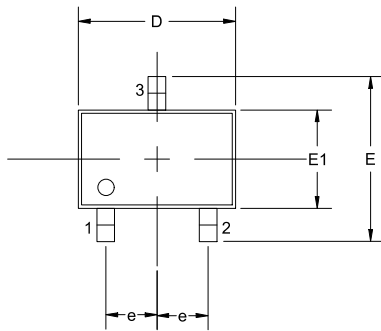

Figure 11. Transient Thermal Response Curve



SC-70, 3 Lead, 1.25x2
CASE 419AB
ISSUE A

DATE 13 FEB 2023



TOP VIEW

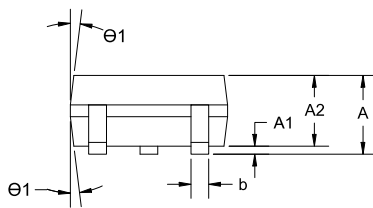

SIDE VIEW

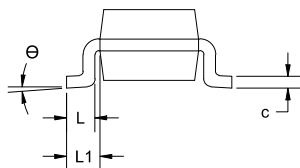

END VIEW

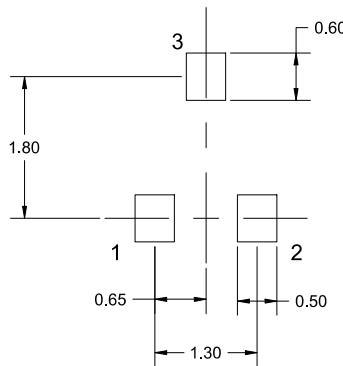

SOLDERING FOOTPRINT

NOTES:

1. ALL DIMENSIONS ARE IN MILLIMETERS. ANGLES IN DEGREES.
2. COMPLIES WITH JEDEC MO-203

DIM	MILLIMETERS		
	MIN.	NOM.	MAX.
A	0.80		1.10
A1	0.00		0.10
A2	0.80	0.90	1.00
b	0.15		0.30
c	0.08		0.22
D	1.80	2.00	2.20
E	1.80	2.10	2.40
E1	1.15	1.25	1.35
e	0.65 BSC		
L	0.26	0.36	0.46
L1	0.42 REF		
θ	0°		8°
θ1	4°		10°

* For additional information on our Pb-Free strategy and soldering details, please download the ON Semiconductor Soldering and Mounting Techniques Reference Manual, SOLDERRM/D.

DOCUMENT NUMBER:	98AON34256E	Electronic versions are uncontrolled except when accessed directly from the Document Repository. Printed versions are uncontrolled except when stamped "CONTROLLED COPY" in red.
DESCRIPTION:	SC-70, 3 LEAD, 1.25X2	PAGE 1 OF 1

onsemi and ONsemi are trademarks of Semiconductor Components Industries, LLC dba onsemi or its subsidiaries in the United States and/or other countries. onsemi reserves the right to make changes without further notice to any products herein. onsemi makes no warranty, representation or guarantee regarding the suitability of its products for any particular purpose, nor does onsemi assume any liability arising out of the application or use of any product or circuit, and specifically disclaims any and all liability, including without limitation special, consequential or incidental damages. onsemi does not convey any license under its patent rights nor the rights of others.

onsemi, **Onsemi**, and other names, marks, and brands are registered and/or common law trademarks of Semiconductor Components Industries, LLC dba "**onsemi**" or its affiliates and/or subsidiaries in the United States and/or other countries. **onsemi** owns the rights to a number of patents, trademarks, copyrights, trade secrets, and other intellectual property. A listing of **onsemi**'s product/patent coverage may be accessed at www.onsemi.com/site/pdf/Patent-Marking.pdf. **onsemi** reserves the right to make changes at any time to any products or information herein, without notice. The information herein is provided "as-is" and **onsemi** makes no warranty, representation or guarantee regarding the accuracy of the information, product features, availability, functionality, or suitability of its products for any particular purpose, nor does **onsemi** assume any liability arising out of the application or use of any product or circuit, and specifically disclaims any and all liability, including without limitation special, consequential or incidental damages. Buyer is responsible for its products and applications using **onsemi** products, including compliance with all laws, regulations and safety requirements or standards, regardless of any support or applications information provided by **onsemi**. "Typical" parameters which may be provided in **onsemi** data sheets and/or specifications can and do vary in different applications and actual performance may vary over time. All operating parameters, including "Typicals" must be validated for each customer application by customer's technical experts. **onsemi** does not convey any license under any of its intellectual property rights nor the rights of others. **onsemi** products are not designed, intended, or authorized for use as a critical component in life support systems or any FDA Class 3 medical devices or medical devices with a same or similar classification in a foreign jurisdiction or any devices intended for implantation in the human body. Should Buyer purchase or use **onsemi** products for any such unintended or unauthorized application, Buyer shall indemnify and hold **onsemi** and its officers, employees, subsidiaries, affiliates, and distributors harmless against all claims, costs, damages, and expenses, and reasonable attorney fees arising out of, directly or indirectly, any claim of personal injury or death associated with such unintended or unauthorized use, even if such claim alleges that **onsemi** was negligent regarding the design or manufacture of the part. **onsemi** is an Equal Opportunity/Affirmative Action Employer. This literature is subject to all applicable copyright laws and is not for resale in any manner.

ADDITIONAL INFORMATION

TECHNICAL PUBLICATIONS:

Technical Library: www.onsemi.com/design/resources/technical-documentation
onsemi Website: www.onsemi.com

ONLINE SUPPORT: www.onsemi.com/support

For additional information, please contact your local Sales Representative at www.onsemi.com/support/sales

