

RF Power Plate Capacitors with Contoured Rim, Class 1 Ceramic



FEATURES

- Low losses
- High reliability
- Wide range of capacitance values

APPLICATIONS

- Induction and dielectric heating
- Antenna coupling
- Filter, bypass and coupling circuits

DESIGN SUPPORT TOOLS

[click logo to get started](#)

3D
Models
Available

QUICK REFERENCE DATA																	
DESCRIPTION	VALUE																
Ceramic class	1																
Ceramic dielectric	R7, R16, R42, R85				R7, R16, R42, R85				R7, R16, R42, R85, R230				R7, R16, R42, R85				
Type	PA 70, PD 70				PA 100, PD 100, PE 100				PA140, PC140, PD140, PE140				PA 200, PC 200, PD 200, PE 200				
Voltage (V_p)	11 000	12 000	13 000	14 000	11 000	13 000	14 000	15 000	12 000	13 000	14 000	15 000	16 000	12 000	13 000	14 000	15 000
Min. capacitance (pF)	800	80	120	25	1600	160	250	50	3000	600	300	100	3000	400	4000	300	160
Max. capacitance (pF)	800	600	500	300	1600	1200	800	200	3000	2500	1600	400	3000	6000	5000	3000	800
Mounting	Screw terminal / band terminal																

MATERIAL

Capacitor elements made from class 1 ceramic dielectric with noble metal electrodes.

Flexible connection terminals made from copper / brass, silver plated, to allow for series and parallel interconnection.

FINISH

Noble metal electrodes and terminals are protective lacquered. The contoured insulating rim is glazed.

MARKING

Type designator, capacitance value and tolerance, rated peak voltage, ceramic material code, production date code, manufacturer logo.

ACCESSORIES ADDED

Two screws and washers (PD, PE)

CAPACITANCE RANGE

25 pF to 6.0 nF

CAPACITANCE TOLERANCE

< 10 pF: ± 2 pF; ± 1 pF; ± 0.5 pF

≥ 10 pF: ± 20 %; ± 10 %; ± 5 %

CERAMIC DIELECTRIC

- R7 (TCC: +100 ppm/K)
- R16 (TCC: +100 ppm/K)
- R42 (TCC: -250 ppm/K)
- R85 (TCC: -750 ppm/K)
- R230 (TCC: -750 ppm/K)

RATED VOLTAGE

- 11 kV_p
- 12 kV_p
- 13 kV_p
- 14 kV_p
- 15 kV_p
- 16 kV_p

DIELECTRIC STRENGTH TEST

200 % of rated voltage, 50 Hz

DISSIPATION FACTOR

R7: max. 0.07 %

R16: max. 0.04 %

R42, R85, R230: max. 0.05 %

Measuring frequencies:

1 MHz (< 1 nF); 300 kHz or 100 kHz (≥ 1 nF)

INSULATION RESISTANCE

Min. 10 000 M Ω (at 25 °C)

OPERATING TEMPERATURE RANGE

-55 °C to +100 °C



SAP PART NUMBER AND ELECTRICAL DATA						
PART NUMBER	CERAMIC	CAP. VALUES (pF)	RATED VOLTAGE (kVp)	RATED POWER ⁽¹⁾ (kvar)	RATED CURRENT (A _{RMS})	
					PD	PA
TYPE P. 70						
P#0070WJ250##BF1	R7	25	14	15	16	10
P#0070WJ300##BF1		30				
P#0070WJ400##BG1	R16	40	14	20		
P#0070WJ500##BG1		50				
P#0070WJ600##BG1		60				
P#0070WF800##BG1		80				
P#0070WJ101##BH1	R42	100	13	20		
P#0070WH121##BH1		120				
P#0070WH161##BH1		160				
P#0070WJ201##BJ1	R85	200	14	20		
P#0070WJ251##BJ1		250				
P#0070WJ301##BJ1		300				
P#0070WH401##BJ1		400				
P#0070WH501##BJ1		500	13			
P#0070WF601##BJ1		600				
P#0070WE801##BJ1		800				

Note

- RoHS-compliant parts on request

SAP PART NUMBER AND ELECTRICAL DATA							
PART NUMBER	CERAMIC	CAP. VALUES (pF)	RATED VOLTAGE (kVp)	RATED POWER ⁽¹⁾ (kvar)	RATED CURRENT (A _{RMS})		
					PE	PD	PA
TYPE P. 100							
P#0100BJ500##BF1	R7	50	15	30	35	25	15
P#0100BJ600##BF1		60					
P#0100BJ800##BG1	R16	80	15	40			
P#0100BJ101##BG1		100					
P#0100BJ121##BG1		120					
P#0100WH161##BG1		160					
P#0100BJ201##BH1	R42	200	13	40			
P#0100WJ251##BH1		250					
P#0100WH301##BH1		300					
P#0100WJ401##BJ1	R85	400	14	40			
P#0100WJ501##BJ1		500					
P#0100WJ601##BJ1		600					
P#0100WJ801##BJ1		800					
P#0100WH102##BJ1		1000	13				
P#0100WH122##BJ1		1200					
P#0100WE162##BJ1		1600					

Notes

- # 2nd digit: code letter of terminal version A, C, D, E
 - ## 14th to 15th digit: capacitance tolerance code ± 20 % = 38; ± 10 % = 36; ± 5 % = 33
 - RoHS-compliant parts on request
- ⁽¹⁾ The surface temperature during operation must not exceed +100 °C



SAP PART NUMBER AND ELECTRICAL DATA							
PART NUMBER	CERAMIC	CAP. VALUES (pF)	RATED VOLTAGE (kV _p)	RATED POWER ⁽¹⁾ (kvar)	RATED CURRENT (A _{RMS})		
					PE	PD	PA, PC
TYPE P. 140							
P#0140BJ101##BF1	R7	100	15	67.5	45	30	20
P#0140BJ121##BF1		120					
P#0140BJ161##BG1	R16	160	15	90			
P#0140BJ201##BG1		200					
P#0140BJ251##BG1		250					
P#0140WJ301##BG1		300					
P#0140BJ401##BH1	R42	400	15	90			
P#0140WJ501##BH1		500	14				
P#0140WH601##BH1		600	13				
P#0140WH801##BH1		800					
P#0140WJ102##BJ1	R85	1000	14	90			
P#0140WJ122##BJ1		1200					
P#0140WJ162##BJ1		1600					
P#0140WH202##BJ1		2000	13				
P#0140WH252##BJ1		2500					
P#0140WF302##BJ1		3000			12		
P#0140WL302##BK1	R230	3000	16	90	45	(2)	(2)

Note

- RoHS-compliant parts on request

SAP PART NUMBER AND ELECTRICAL DATA								
PART NUMBER	CERAMIC	CAP. VALUES (pF)	RATED VOLTAGE (kV _p)	RATED POWER ⁽¹⁾ (kvar)	RATED CURRENT (A _{RMS})			
					PE	PD	PA, PC	
TYPE P. 200								
P#0200BJ161##BF1	R7	160	15	112	60	40	25	
P#0200BJ201##BF1		200						
P#0200BJ251##BF1		250						
P#0200WJ301##BF1		300						14
P#0200WF401##BF1		400						12
P#0200BJ501##BG1	R16	500	15	150				
P#0200BJ601##BG1		600						
P#0200BJ801##BH1	R42	800	15	150				
P#0200WJ102##BH1		1000	14					
P#0200WJ122##BH1		1200						
P#0200WJ162##BH1		1600						
P#0200WJ202##BJ1	R85	2000	14	150				
P#0200WJ252##BJ1		2500						
P#0200WJ302##BJ1		3000						
P#0200WH402##BJ1		4000	13					
P#0200WH502##BJ1		5000						
P#0200WF602##BJ1		6000			12			

Notes

- # 2nd digit: code letter of terminal version A, C, D, E
- ## 14th to 15th digit: capacitance tolerance code ± 20 % = 38; ± 10 % = 36; ± 5 % = 33
- RoHS-compliant parts on request

(1) The surface temperature during operation must not exceed +100 °C

(2) Only PE type available

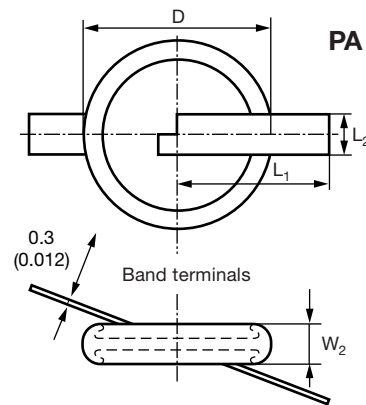
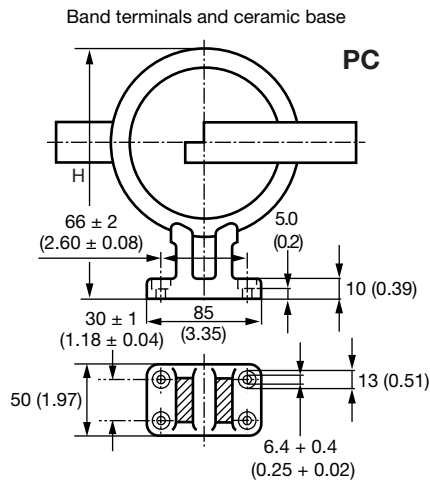
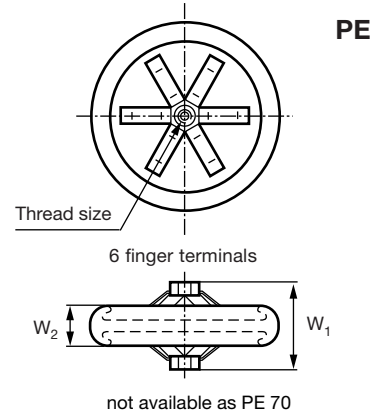
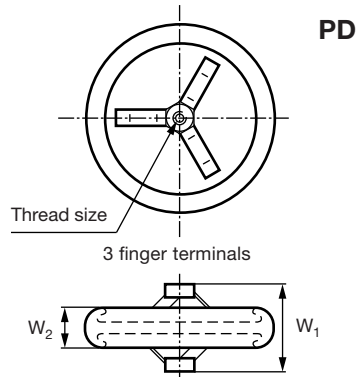
DIMENSIONS in millimeters (inches)

TYPE	PA 70 PD 70 (2)	PA 100 PD 100 PE 100 (3)	PA 140 PC 140 PD 140 PE 140	PA 200 PC 200 PD 200 PE 200
Diameter D	70 ± 2 (2.76 ± 0.08)	100 ± 2 (3.94 ± 0.08)	140 ± 3 (5.51 ± 0.12)	200 ± 4 (7.87 ± 0.16)
Thread size	M6	M8	M8	M10
Width W_1	35 ± 1 (1.38 ± 0.04)	40 ± 1 (1.58 ± 0.04)	40 ± 1 (1.58 ± 0.04)	45 ± 1 (1.77 ± 0.04)
Width $W_{2 \text{ max.}}$ (1)	31 (1.22)	31 (1.22)	31 (1.22)	32 (1.26)
Height H	-	-	186 ± 5 (7.32 ± 0.20)	246 ± 5 (9.69 ± 0.20)
Length L_1	100 ± 5 (3.94 ± 0.20)	145 ± 5 (5.71 ± 0.20)	145 ± 5 (5.71 ± 0.20)	255 ± 5 (10.04 ± 0.20)
Length L_2	15 ± 0.5 (0.59 ± 0.02)	30 ± 0.5 (1.18 ± 0.02)	30 ± 0.5 (1.18 ± 0.02)	30 ± 0.5 (1.18 ± 0.02)

Notes

- (1) Dimension W_2 will vary depending upon capacitance
- (2) Types PC 70 and PE 70 are not available
- (3) Type PC 100 is not available

RELATED DOCUMENTS

General Information

www.vishay.com/doc?22071



Disclaimer

ALL PRODUCT, PRODUCT SPECIFICATIONS AND DATA ARE SUBJECT TO CHANGE WITHOUT NOTICE TO IMPROVE RELIABILITY, FUNCTION OR DESIGN OR OTHERWISE.

Vishay Intertechnology, Inc., its affiliates, agents, and employees, and all persons acting on its or their behalf (collectively, "Vishay"), disclaim any and all liability for any errors, inaccuracies or incompleteness contained in any datasheet or in any other disclosure relating to any product.

Vishay makes no warranty, representation or guarantee regarding the suitability of the products for any particular purpose or the continuing production of any product. To the maximum extent permitted by applicable law, Vishay disclaims (i) any and all liability arising out of the application or use of any product, (ii) any and all liability, including without limitation special, consequential or incidental damages, and (iii) any and all implied warranties, including warranties of fitness for particular purpose, non-infringement and merchantability.

Statements regarding the suitability of products for certain types of applications are based on Vishay's knowledge of typical requirements that are often placed on Vishay products in generic applications. Such statements are not binding statements about the suitability of products for a particular application. It is the customer's responsibility to validate that a particular product with the properties described in the product specification is suitable for use in a particular application. Parameters provided in datasheets and / or specifications may vary in different applications and performance may vary over time. All operating parameters, including typical parameters, must be validated for each customer application by the customer's technical experts. Product specifications do not expand or otherwise modify Vishay's terms and conditions of purchase, including but not limited to the warranty expressed therein.

Hyperlinks included in this datasheet may direct users to third-party websites. These links are provided as a convenience and for informational purposes only. Inclusion of these hyperlinks does not constitute an endorsement or an approval by Vishay of any of the products, services or opinions of the corporation, organization or individual associated with the third-party website. Vishay disclaims any and all liability and bears no responsibility for the accuracy, legality or content of the third-party website or for that of subsequent links.

Except as expressly indicated in writing, Vishay products are not designed for use in medical, life-saving, or life-sustaining applications or for any other application in which the failure of the Vishay product could result in personal injury or death. Customers using or selling Vishay products not expressly indicated for use in such applications do so at their own risk. Please contact authorized Vishay personnel to obtain written terms and conditions regarding products designed for such applications.

No license, express or implied, by estoppel or otherwise, to any intellectual property rights is granted by this document or by any conduct of Vishay. Product names and markings noted herein may be trademarks of their respective owners.