

No.: SPC-K-HTS-0001 /5
Date: 2023. 1. 25

Data sheet

Title: ESD SUPPRESSOR; RECTANGULAR TYPE

Style: SPC10

RoHS COMPLIANCE ITEM
Halogen and Antimony Free

- Note:
- Stock conditions
Temperature: +5°C ~ +35°C
Relative humidity: 25% ~ 75%
The period of guarantee: Within 2 year from shipment by the company.
Solderability shall be satisfied.
 - Product specification contained in this data sheet are subject to change at any time without notice
 - If you have any questions or a Purchasing Specification for any quality agreement is necessary, please contact our sales staff.



釜屋電機株式會社
KAMAYA ELECTRIC CO., LTD.

Hokkaido Research Center
Approval by: T. Sannomiya
Drawing by: M. Shibuya

1. Scope

1.1 This data sheet covers the detail requirements for ESD suppressor; rectangular type, style of SPC10.

2. Classification

Type designation shall be the following form.

(Example)

SPC	10	501	A	01	TH
1	2	3	4	5	6

1 ESD suppressor; rectangular type Style

2 Size

3 Peak voltage

Symbol	Peak voltage
501	50×10 ¹ V

4 Rated voltage

Symbol	Rated voltage
A	30V max
C	50V max

5 Optional code

Symbol	Optional code
01	Capacitance: 0.1 pF max.

6 Packaging form

B	Bulk (loose package)
TH	Paper taping

3. Rating

3.1 The ratings shall be in accordance with Table-1.

Table-1

Style	ESD capability *1			Rated voltage (V)	Capacitance (pF) *2	Leakage current (μA)
	Peak voltage (V)	Clamping voltage (V)	ESD pulse withstand (pulses)			
SPC10	500 max.	100 max.	100	30 max. 50 max.	0.1 max.	1 max.

Style	Category temperature range (°C)
SPC10	-55 to +125

*1 Peak voltage: IEC61000-4-2, 8kV, Contact discharge, The peak voltage shall be measured.

Clamping voltage: IEC61000-4-2, 8kV, Contact discharge, The voltage value shall be measured after 30ns from the peak voltage.

ESD pulse withstand: IEC61000-4-2, 8kV, Contact discharge, The pulse withstand.

*2 Capacitance: 25°C, 1MHz, 1Vrms

4. Packaging form

The standard packaging form shall be in accordance with Table-2.

Table-2

Symbol	Packaging form		Standard packaging quantity / units
B	Bulk (loose package)		1,000 pcs.
TH	Paper taping	8mm width, 2mm pitches	10,000 pcs.

5. Dimensions

5.1 The suppressor shall be of the design and physical dimensions in accordance with Figure-1 and Table-3.

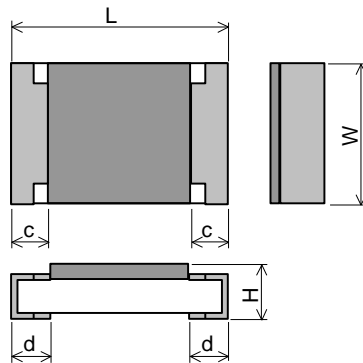

Figure-1

Table-3

Unit : mm

Style	L	W	H	c	d
SPC10	1.0±0.05	0.5±0.05	0.35±0.05	0.2±0.10	0.25±0.10

5.2 Equivalent circuits

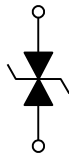

6. Performance

6.1 Unless otherwise specified, the standard range of atmospheric conditions for tests is as follows;

Ambient temperature: 5 °C to 35 °C, Relative humidity: 45 % to 85 %, Air presser: 86 kPa to 106 kPa

If there is any doubt the results, measurements shall be made within the following:

Ambient temperature: 20 °C ± 2 °C, Relative humidity: 60 % to 70 %, Air presser: 86 kPa to 106 kPa

6.2 The performance shall be satisfied in Table-4.

Table-4(1)

No.	Test items	Condition of test	Performance requirements
1	ESD capability Peak voltage	IEC61000-4-2 The suppressor shall be mounted on the test substrate as shown in Figure-2. Test condition: 8kV, Contact discharge Measurement: The peak voltage shall be measured.	500V max.
2	ESD capability Clamp voltage	IEC61000-4-2 The suppressor shall be mounted on the test substrate as shown in Figure-2. Test condition: 8kV, Contact discharge Measurement: The voltage value shall be measured after 30ns from the peak voltage.	100V max.
3	ESD capability ESD pulse withstand	IEC61000-4-2 The suppressor shall be mounted on the test substrate as shown in Figure-2. Test condition: 8kV, Contact discharge Applied pulses: 100 pulses Measurement: After examination, the current value when the rated voltage is applied is measured.	10 μ A max.
4	Capacitance	Measurement condition: Frequency: 1MHz \pm 10% Voltage: 1 Vrms \pm 0.2Vrms Ambient temperature: 25°C \pm 2 °C	0.1pF max.
5	Leakage current	Measurement voltage: Rated voltage Measurement: The current value when the measurement voltage is applied is measured.	1 μ A max.
6	Terminal bond strength of the face plating	JIS C 60068-2-21 The suppressor shall be mounted on the test substrate as shown in Figure-2. Bending value: 3 mm (Among the fulcrums: 90 mm) Duration: 10 s \pm 1 s	Leakage current: 10 μ A max. No evidence of mechanical damage.
7	Resistance to soldering heat	JIS C 60068-2-58 Test by a piece. Temp. of solder bath: 260 °C \pm 5 °C Immersion time: 10 s \pm 1 s After immersion into solder, leaving the room temp. for 48h or more, and then measure the leakage current. • Reflow soldering Pre-heating: 150 °C ~ 180 °C, 120 s max. Peak: 260 °C \pm 5 °C, 10 s max. Reflow cycle: 2 times After immersion into solder, leaving the room temp. for 48h or more, and then measure the leakage current.	Leakage current: 10 μ A max. No evidence of appearance damage
8	Solderability	JIS C 60068-2-58 Test by a piece Flux: Rosin-Methanol Temp. of solder bath: 235 °C \pm 5 °C Immersion time: 2 s \pm 0.5 s	The surface of terminal immersed shall be min. of 95 % covered with a new coating of solder.

Product specification contained in this data sheet are subject to change at any time without notice.

If you have any questions or a Purchasing Specification for any quality agreement is necessary, please contact our sales staff.

Issue: KAMAYA ELECTRIC CO., LTD. Research & Development Department HOKKAIDO Research center Last update: 2023.1.25

Table-4(2)

9	Solvent	JIS C 60068-2-45 The specimen shall be cleansed at normal temperature for 90s using Isopropyl alcohol.	No evidence of appearance damage
10	Rapid change temperature	JIS C 60068-2-14 The suppressor shall be mounted on the test substrate as shown in Figure-2. Lower temperature: -55 °C Upper temperature: +125 °C Duration of exposure at each temperature: 30 min. Number of cycles: 100 cycles After examination, leaving the room temp. for 48h or more, and then measure the leakage current.	Leakage current: 10μA max. No evidence of appearance damage
11	Humidity (Steady state)	JIS C 60068-2-78 The suppressor shall be mounted on the test substrate as shown in Figure-2. Test temp. & relative humidity: 60±2°C & 90~95% RH. Test period: 1,000 ⁺⁴⁸ ₀ h After examination, leaving the room temp. for 48h or more, and then measure the leakage current.	Leakage current: 10μA max. No evidence of appearance damage
12	Load life in humidity	The suppressor shall be mounted on the test substrate as shown in Figure-2. Test temp. & relative humidity: 60±2°C & 90~95% R.H. Test voltage: Rated voltage shall be applied continuously. Test period: 1,000 ⁺⁴⁸ ₀ h After examination, leaving the room temp. for 48h or more, and then measure the leakage current.	Leakage current: 10μA max. No evidence of appearance damage
13	Endurance at 85 °C	The suppressor shall be mounted on the test substrate as shown in Figure-2. Test temp.: 85±2°C Test voltage: Rated voltage shall be applied continuously. Test period: 1,000 ⁺⁴⁸ ₀ h After examination, leaving the room temp. for 48h or more, and then measure the leakage current.	Leakage current: 10μA max. No evidence of appearance damage

7. Test substrate

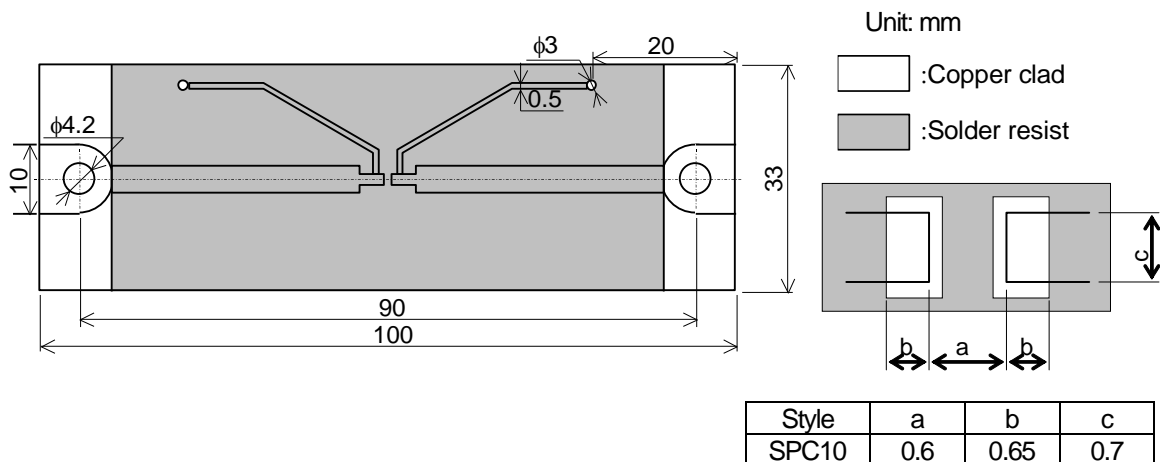

Figure-2 SPC TEST SUBSTRATE

Remark 1). Material: Epoxide woven glass

Thickness: 1.6mm Thickness of copper clad: 0.035mm

8.3 Reel dimension

Reel dimensions shall be in accordance with the following Figure-5 and Table-6.

Plastic reel (Based on EIAJ ET-7200C)

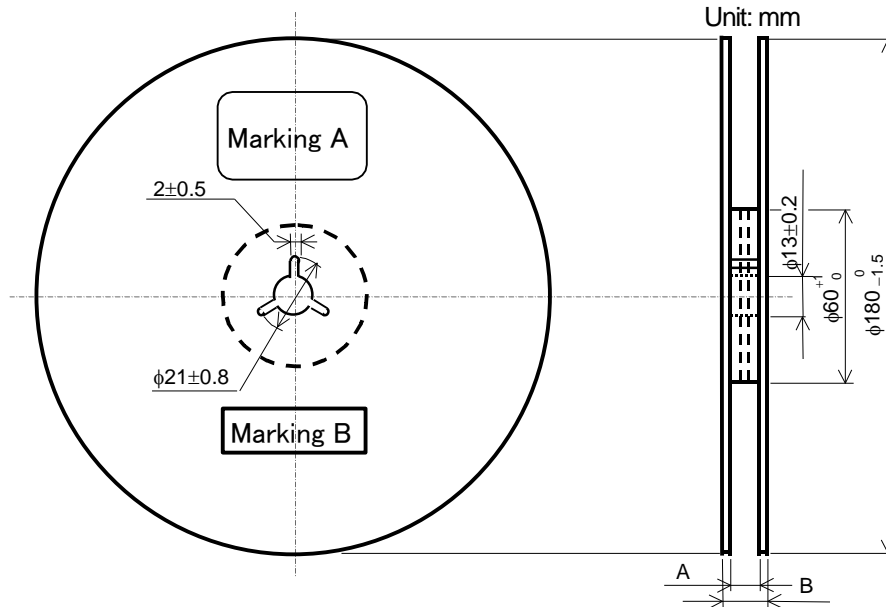

Figure-5

Table-6

Unit: mm

Style	A	B	Note
SPC10	9 ^{+1.0} ₀	11.4±1.0	Injection molding
		13±1.0	Vacuum forming

Note: Marking label shall be marked on a place of Marking A or two place of marking A and B.

8.4 Leader and trailer tape.

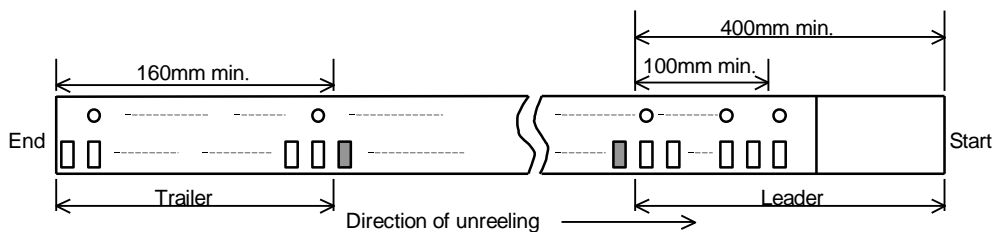

Figure-6

9. Marking on package

The label of a minimum package shall be legibly marked with follows.

9.1 Marking A

(1) Classification (Style, Peak voltage, Rated voltage, Optional code, Packaging form) (2) Quantity (3) Lot number

(4) Manufacturer's name or trade mark (5) Others

9.2 Marking B (KAMAYA Control label)