



IP65 IP68 (optional)
UL62368-1 TPTC004 IEC62368-1



Features

- Universal AC input / Full range
- Built-in active PFC function
- High efficiency up to 94%
- Fanless design, cooling by free air convection
- -55~+70°C wide operating range
- Aluminum case and filling with heat-conducted silicone
- IP65 design, optional IP68 rated model available
- Meet 6KV surge immunity level
- Withstand 10G vibration test
- Protections: Short circuit / Overload / Over voltage / Over temperature
- Operating altitude up to 5000 meters (Note.9)
- 6 years warranty

Applications

- Outdoor telecommunication equipment
- Outdoor electronic signage and billboard
- Petroleum plant or mine shaft facility

GTIN CODE

MW Search: <https://www.meanwell.com/serviceGTIN.aspx>

Description

HEP-185 is a 185W industrial AC/DC power supply featuring the outstanding capability to operate under highly humid, dusty, oily, and high-vibration harsh environment. The entire series is housed with the aluminum case and fully potted with heat-conducted silicone. Thanks to state-of-the-art design, the working efficiency is up to 94%, enabling HEP-185 perfectly work between -55°C and +70°C under free air convection.

Model Encoding

HEP - 185 - 12 A

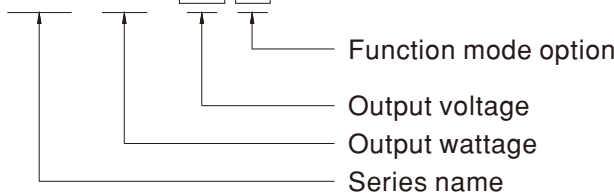

{ A : Standard model, IP65, Vo and Io level can be adjusted through internal potentiometer.
Blank : Optional model, IP68, with fixed Vo and Io level.

SPECIFICATION

MODEL		HEP-185-12□	HEP-185-15□	HEP-185-24□	HEP-185-36□	HEP-185-48□	HEP-185-54□	
OUTPUT	DC VOLTAGE	12V	15V	24V	36V	48V	54V	
	RATED CURRENT	13A	11.5A	7.8A	5.2A	3.9A	3.45A	
	RATED POWER	156W	172W	187.2W	187.2W	187.2W	186.3W	
	RIPPLE & NOISE (max.) Note.2	150mVp-p	150mVp-p	150mVp-p	200mVp-p	200mVp-p	200mVp-p	
	VOLTAGE ADJ. RANGE Note.5	10.8 ~ 13.5V	13.5 ~ 17V	22 ~ 27V	33 ~ 40V	43 ~ 53V	49 ~ 58V	
	CURRENT ADJ. RANGE	Can be adjusted by internal potentiometer for A type only						
		6.5 ~ 13A	5.75 ~ 11.5A	3.9 ~ 7.8A	2.6 ~ 5.2A	1.95 ~ 3.9A	1.72 ~ 3.45A	
	VOLTAGE TOLERANCE Note.3	±2.5%	±2.0%	±1.0%	±1.0%	±1.0%	±1.0%	
	LINE REGULATION	±0.5%	±0.5%	±0.5%	±0.5%	±0.5%	±0.5%	
	LOAD REGULATION	±2.0%	±1.5%	±0.5%	±0.5%	±0.5%	±0.5%	
SETUP, RISE TIME Note.7	1000ms,50ms/115VAC 500ms,50ms/230VAC at full load							
HOLD UP TIME (Typ.)	16ms at full load 230VAC /115VAC							
INPUT	VOLTAGE RANGE Note.4	90~264VAC (277VAC operational)		128~370VDC(390VDC operational)				
	FREQUENCY RANGE	47 ~ 63Hz						
	POWER FACTOR (Typ.)	PF>0.98/115VAC, PF>0.95/230VAC, PF>0.92/277VAC at full load						
	EFFICIENCY (Typ.)	91.5%	92%	93.5%	93.5%	94%	94%	
		AC CURRENT (Typ.)	12V	1.8A / 115VAC	0.8A / 230VAC	0.7A / 277VAC		
		15V ~ 54V	2.1A / 115VAC	1A / 230VAC	0.8A / 277VAC			
	INRUSH CURRENT(Typ.)	COLD START 65A at 230VAC						
LEAKAGE CURRENT	<0.75mA / 277VAC							
PROTECTION	OVERLOAD	105 ~ 125%						
		Protection type : Constant current limiting, recovers automatically after fault condition is removed						
	SHORT CIRCUIT	Constant current limiting, recovers automatically after fault condition is removed						
	OVER VOLTAGE	14 ~ 17V	18 ~ 21V	28 ~ 34V	41 ~ 46V	54 ~ 63V	59 ~ 65V	
		Protection type : Shut down o/p voltage with auto-recovery or re-power on to recovery						
OVER TEMPERATURE	Shut down o/p voltage, recovers automatically after temperature goes down							
ENVIRONMENT	WORKING TEMP.	-55 ~ +70°C (Refer to "Derating Curve")						
	WORKING HUMIDITY	20 ~ 95% RH non-condensing						
	STORAGE TEMP., HUMIDITY	-60 ~ +80°C, 10 ~ 95% RH non-condensing						
	TEMP. COEFFICIENT	±0.03%/°C (0 ~ 60°C)						
	VIBRATION	20 ~ 500Hz, 10G 12min./1cycle, period for 72min. each along X, Y, Z axes						
SAFETY & EMC	SAFETY STANDARDS Note.6,9	UL62368-1, IEC62368-1, IP65 (or IP68 for HEP-185 Blank type), EAC TP TC 004 approved ; Design refer to BS EN/EN62368-1						
	WITHSTAND VOLTAGE	I/P-O/P:3.75KVAC I/P-FG:2KVAC O/P-FG:1.5KVAC						
	ISOLATION RESISTANCE	I/P-O/P, I/P-FG, O/P-FG:100M Ohms / 500VDC / 25°C / 70% RH						
	EMC EMISSION	Compliance to BS EN/EN55032 (CISPR32) Class B, BS EN/EN61000-3-2,-3, EAC TP TC 020						
	EMC IMMUNITY	Compliance to BS EN/EN61000-4-2,3,4,5,6,8,11, BS EN/EN55035, light industry level (surge 6KV), EAC TP TC 020						
OTHERS	MTBF	1967.4K hrs min. Telcordia SR-332(Bellcore) ; 164.2K hrs min. MIL-HDBK-217F (25°C)						
	DIMENSION	228*68*38.8mm (L*W*H)						
	PACKING	1.15Kg; 12pcs/14.8Kg/0.8CUFT						
NOTE	<p>1. All parameters NOT specially mentioned are measured at 230VAC input, rated load and 25°C of ambient temperature.</p> <p>2. Ripple & noise are measured at 20MHz of bandwidth by using a 12" twisted pair-wire terminated with a 0.1uf & 47uf parallel capacitor.</p> <p>3. Tolerance : includes set up tolerance, line regulation and load regulation.</p> <p>4. Derating may be needed under low input voltages. Please check the static characteristics for more details.</p> <p>5. A type only.</p> <p>6. Safety and EMC design refer to BS EN/EN60598-1, CNS15233, GB7000.1, FCC part18.</p> <p>7. Length of set up time is measured at cold first start. Turning ON/OFF the power supply may lead to increase of the set up time.</p> <p>8. The power supply is considered as a component that will be operated in combination with final equipment. Since EMC performance will be affected by the complete installation, the final equipment manufacturers must re-qualify EMC Directive on the complete installation again. (as available on https://www.meanwell.com/Upload/PDF/EMI_statement_en.pdf)</p> <p>9. The water protection level test for the IP68 rating is performed 1000mm below the surface of the water for 1 month.</p> <p>10. The ambient temperature derating of 3.5°C/1000m with fanless models and of 5°C/1000m with fan models for operating altitude higher than 2000m(6500ft).</p> <p>※ Product Liability Disclaimer : For detailed information, please refer to https://www.meanwell.com/serviceDisclaimer.aspx</p>							

Block Diagram

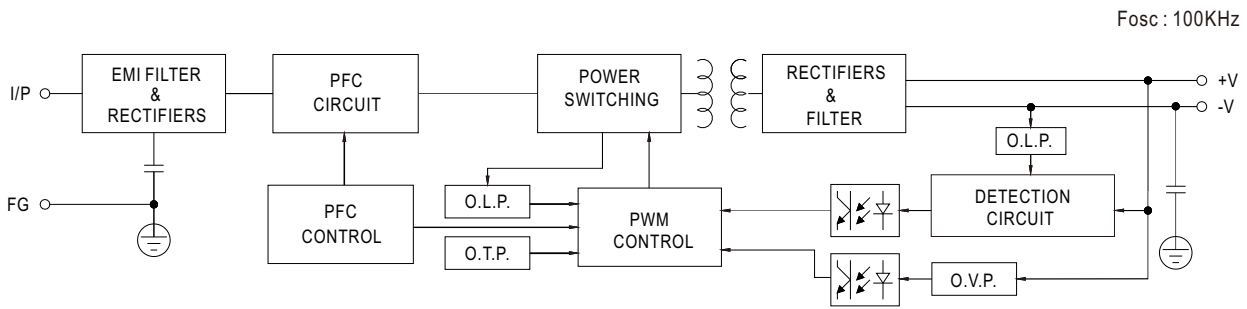

Derating Curve

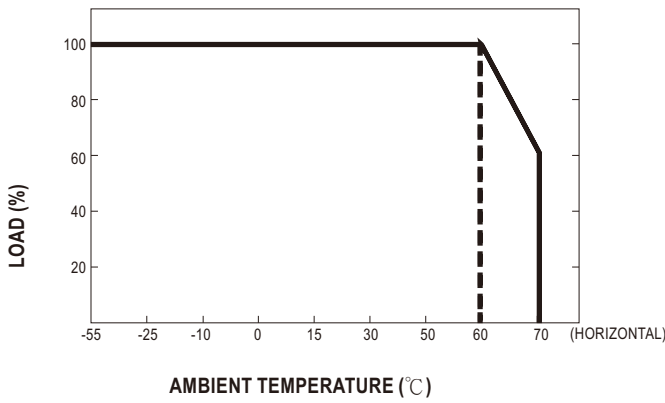

Static Characteristics

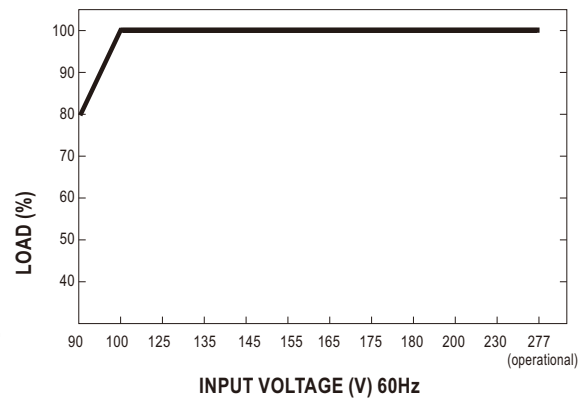

Mechanical Specification

Case No.994D Unit:mm Tolerance:±1

A Type: HEP-185- A(standard model)

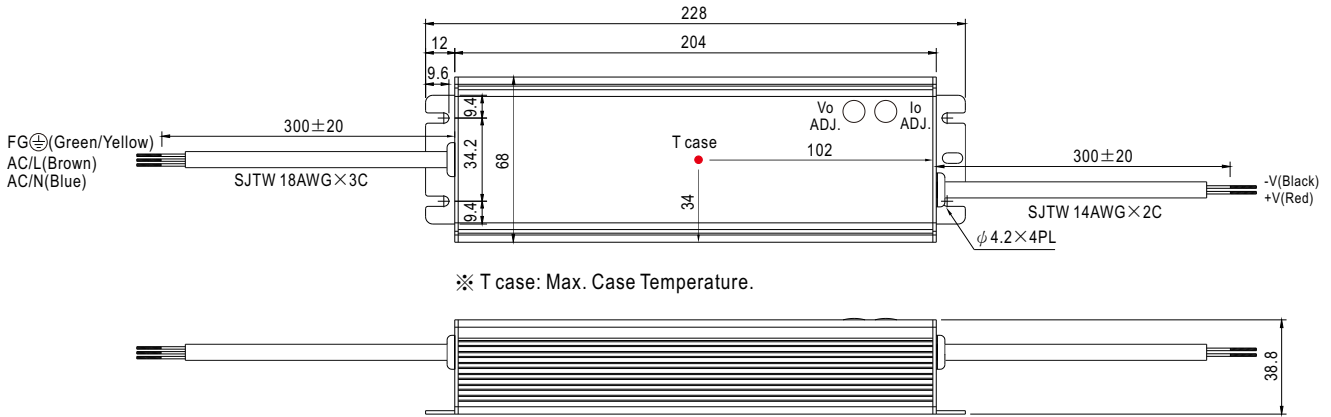

※ T case: Max. Case Temperature.

※ IP65 rated. Output voltage and constant current level can be adjusted through internal potentiometer.
(Can access by removing the rubber stopper on the case.)

Blank: HEP-185(optional model)

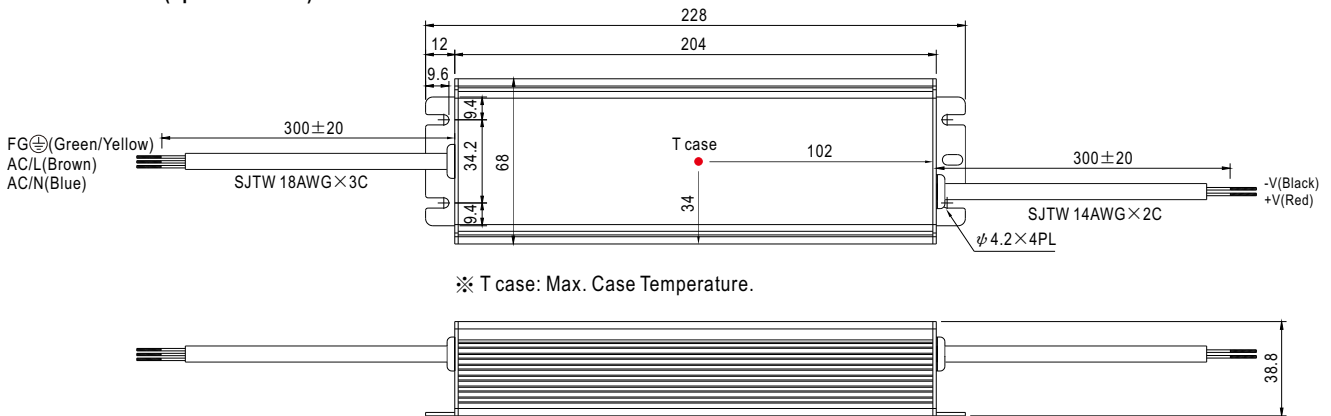

※ T case: Max. Case Temperature.

※ IP68 rated. Cable for I/O connection.

Installation Manual

Please refer to : <http://www.meanwell.com/manual.html>