

Amplifier Built-in

Compact Photoelectric Sensor

CX-400 SERIES Ver.2



Global Standard



Upgraded to Increase Usability

Achieving low power consumption and high noise-resistance

The basic types are added in lineup

The global standard CX-400 series Sensors that are environmentally and user friendly.

The various lineup covers through the inclusion of a newly developed custom integrated circuit. The **CX-400** series achieves a significantly higher reliability in the same package than previous models.



Providing stable detection with low power consumption
**Includes an analog CMOS
processor ASIC**

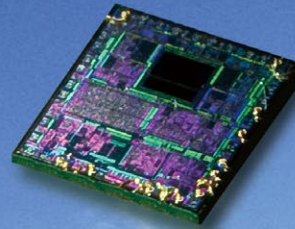

The Three Keywords Expressing **CX-400** Series' World-Class Performance

Strong

**Stable detection even in dusty
or wet environments**



Achieving the IP67 protection rating (IEC), the **CX-400** series can be used safely in environments where water and dust are present.

Caution: The sensor may detect water if water splashes on the unit during detection operation.



Upgrade 1

Reducing environmental burdens further

Up to 60% less power consumption

The **CX-400** series achieves reductions in power consumption of up to 60%, averaging 44% reduction when upgrading due to its unique design. These sensors reduce carbon emissions and contribute to environmental friendliness.

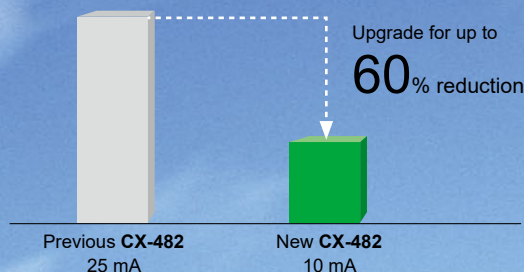

Contributing to reduced carbon dioxide emissions

Electricity consumed by the **CX-400** series has been reduced on average 10.5 mA. Calculating 8 hours/day, 260 days (operating 5 days/week) for a total of 2,080 hours/year leads to:

The **CX-400** contributes

Approx. 84.6 t annually in carbon dioxide reductions to the world

Upgrade 2

Stronger noise resistance

Stronger inverter countermeasures

The **CX-400** has a high noise resistance then its previous model. By incorporating an inverter countermeasure circuit that appropriately shifts with peak wavelength, the sensor now resists high-frequency noise from high-voltage inverter motors and inverter lights more effectively.

Upgrade 3

Stronger output short-circuit resistance

Stronger inverse wiring connection protection

Strengthening the output circuit inverse polarity protection prevents sensor damage caused by mistaken output or power supply wiring.

High Performance

High performance for many applications



The **CX-400** series is capable of stably detecting a minute difference of 0.4 mm **0.016 in** (the thickness of a business card) or 10 μm **0.394 mil** ultra-thin film, thanks to its unique optics and specialized design of electronic circuits. Bright red beam spot is useful when confirming a detection position.

Save

Thoroughly eliminating unnecessary waste, reducing many environmental burdens



The **CX-400** series has three different cable length types and uses very simple packaging to reduce waste. The bag is made of polyethylene and does not emit toxic gasses.

Thru-beam type

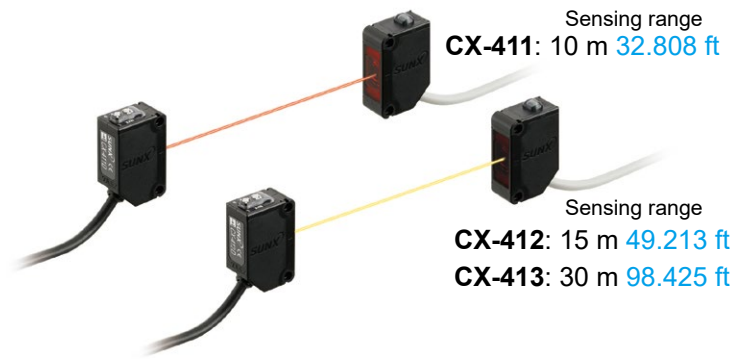

Strong infrared beam

CX-412/413

Remarkable penetrating ability enables applications such as package content detection come into practice.

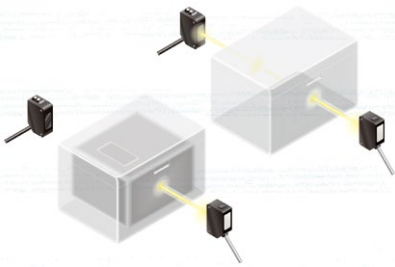

Note: When utilizing penetrating power in detection, make sure to verify using the actual sensor.

Strong in dust and dirt

CX-412/413

The infrared light source is strong in dust and dirt compared to the red beam type.

Even the thru-beam type is strong at mutual interference

CX-411

Two **CX-411** sensors, with their red beam light source, can be installed close together by inserting an interference prevention filter.

Interference prevention filter (Optional)

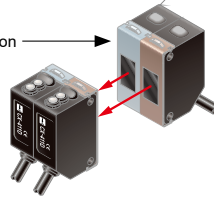

Applications

- Detecting box collapsing within the rail of stacker crane

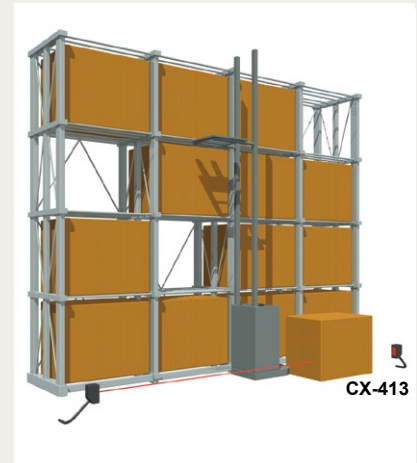

- Synchronizing sensor for image processing systems

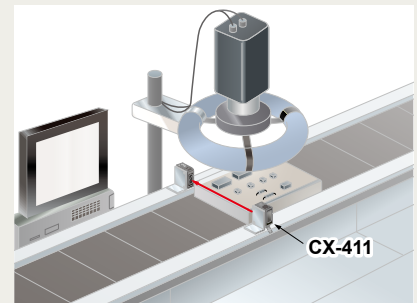

Retroreflective type

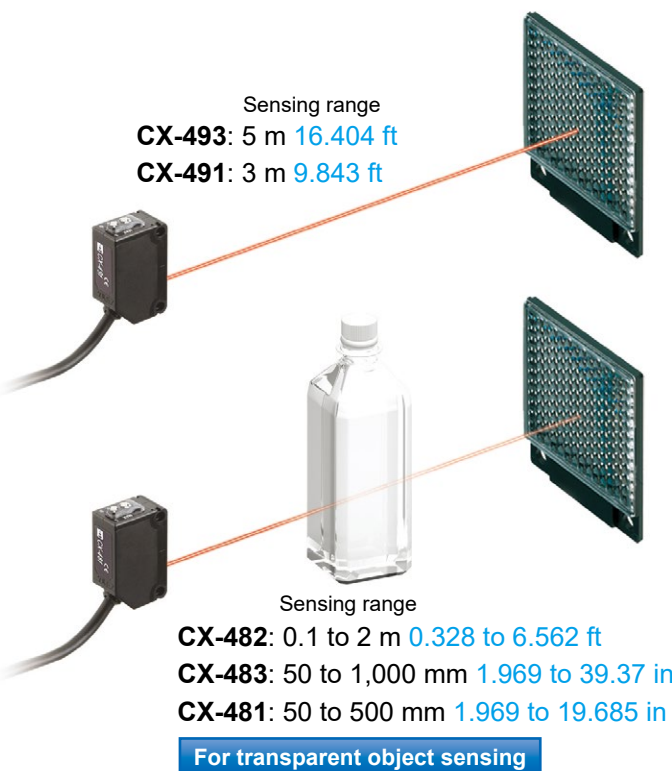

Long sensing range of 5 m 16.404 ft

CX-493

A long 5 m 16.404 ft sensing range is possible with the red LED type that is easy to align with the beam axis. The sensors can be used for wide automatic door shutters.

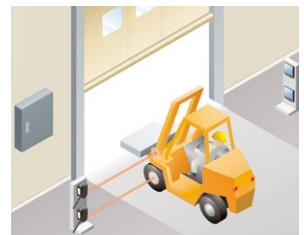

Retroreflective type with polarizing filters

CX-491

Built-in polarizing filters ensure stable sensing even on a mirror surface object.

Two sensors can be mounted close together

CX-49□/48□

Up to two sensors can be mounted closely by the automatic interference prevention function.

Diffuse reflective type

Sensing range
CX-422: 800 mm **31.496 in**
CX-421: 300 mm **11.811 in**
CX-424: 100 mm **3.937 in**

Sensing range
CX-423: 70 to 300 mm
2.756 to 11.811 in
Narrow-view type

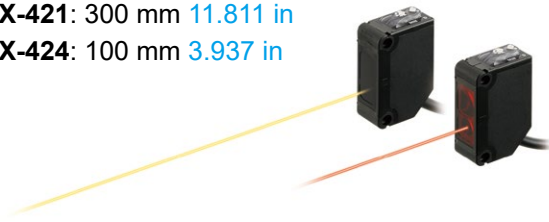

Beam axis alignment made easy with a high luminance spot beam

CX-423

These sensors have a high luminance red LED spot beam which provides bright visibility enabling the sensing position to be checked at a glance. Because it achieved small beam spot approx. $\varnothing 2$ mm $\varnothing 0.079$ in at setting distance 100 mm **3.937 in**, approx. $\varnothing 5$ mm $\varnothing 0.197$ in at setting distance 200 mm **7.874 in**, even the minutest object can be accurately detected.

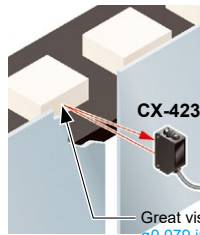

Great visibility approx. $\varnothing 2$ mm $\varnothing 0.079$ in high luminance spot beam (at setting distance 100 mm **3.937 in**)

Reduction of volume adjustment labor

CX-42□

Because these sensors possess many variations depending on the sensing range, they enable you to make optimal volume adjustment easily.

Two sensors can be mounted close together

CX-42□

Up to two sensors can be mounted closely by the automatic interference prevention function.

Applications

Detecting pins in the case

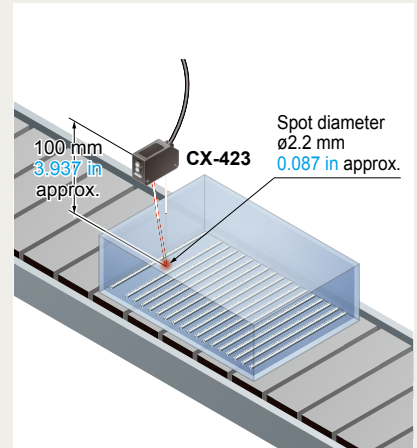

Passage confirmation on substrate conveyor equipment

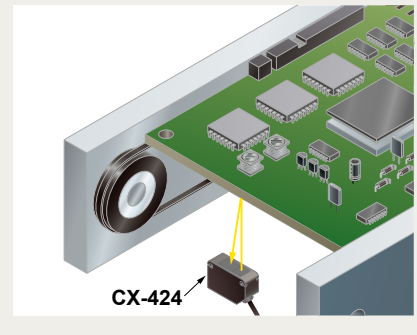

Transparent object sensing type sensor

CX-48□

Our unique optical system and transparent object sensing circuit provide stable sensing of thinner transparent objects than the conventional models.

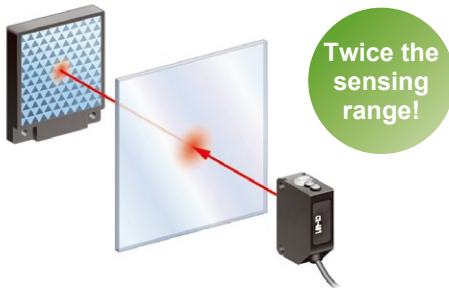

Transparent objects detectable with CX-48□ (Typical examples)

Sensing object	Sensing object size (mm in)			
Glass sheet	□50	□1.969	t=0.7	t=0.028
Cylindrical glass	∅50	∅1.969	ℓ=50	ℓ=1.969
Acrylic board	□50	□1.969	t=1.0	t=0.039
Styrol (Floppy case)	□50	□1.969	t=0.9	t=0.035
Food wrapping film	□50	□1.969	t=10 μm	t=0.394 mil
Cigarette case film	□50	□1.969	t=20 μm	t=0.787 mil
Vinyl bag	□50	□1.969	t=30 μm	t=1.181 mil
Pet bottle (500ml)	∅66	∅2.598		

Reflector setting range **CX-481:** 300 to 500 mm **11.811 to 19.685 in**

CX-482: 1 to 2 m **3.281 to 6.562 ft**

CX-483: 500 to 1,000 mm **19.685 to 39.370 in**

[with the **RF-230** reflector at the optimum condition (Note)]

Each object should pass across the beam at the center between the sensor and the reflector.

ℓ : Length of cylindrical glasses

t : Thickness of sensing object

Note: The optimum condition is defined as the condition in which the sensitivity level is set such that the stability indicator just lights up when the object is absent.

Applications

Detecting glossy electric appliances

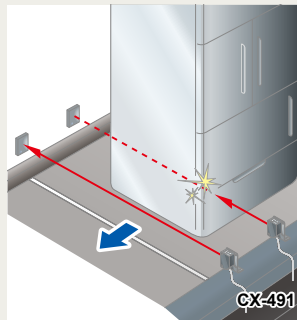

Detecting plastic bottles stacked on pallets

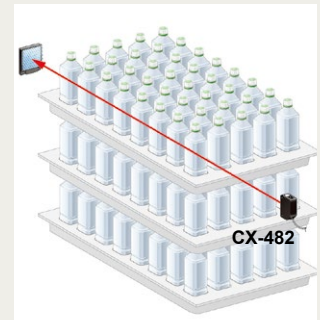

Passage confirmation of object on a conveyor belt

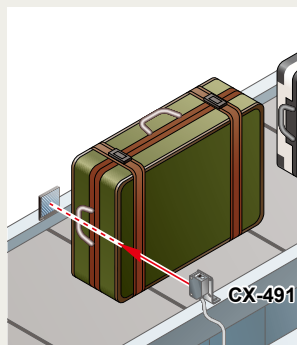

Detecting TAB protective transparent film

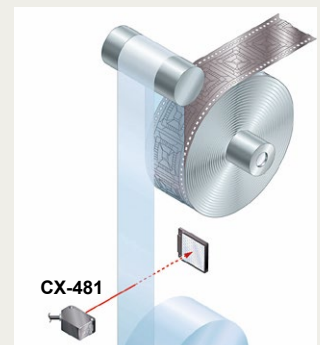

Adjustable range reflective type

Adjustable range
40 to 300 mm **1.575 to 11.811 in**
Spot size □15 mm □0.591 in approx.

CX-442

CX-444

CX-441

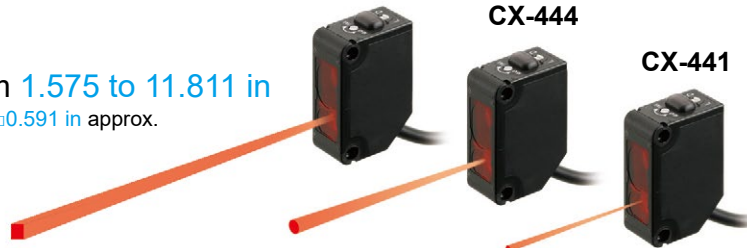

Adjustable range
20 to 100 mm **0.787 to 3.937 in**
Spot diameter ø9 mm ø0.354 in approx.

Adjustable range
20 to 50 mm **0.787 to 1.969 in**
Spot diameter ø2 mm ø0.079 in approx.

High precision type

CX-441/444

*At the maximum distance

Can sense height differences as small as 0.4 mm 0.016 in, with hysteresis of 2 % or less

An advanced optical system provides sensing performance that is approx. 2.5 times than conventional models. Even ultra-small differences of 0.4 mm 0.016 in can be detected accurately.

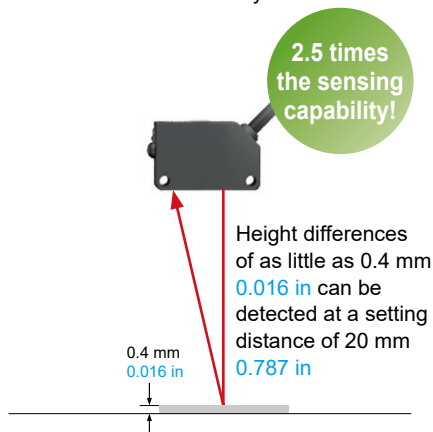

Hardly affected by colors

Both black and white objects can be sensed at the same distances. No adjuster control is needed, even when products of different colors are moving along the production line.

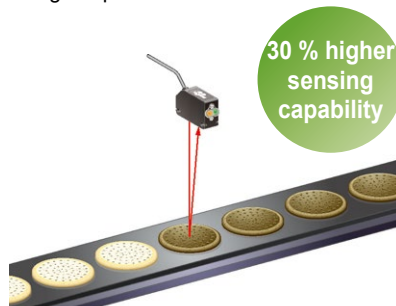

The difference in sensing range 1% or less between non-glossy white paper with a setting distance of 50 mm 1.969 in and non-glossy gray paper with a brightness level of 5.

Select from 2 spot diameters as per application

We offer small spot type for detecting minute objects and large spot type capable of sensing objects covered with holes and grooves.

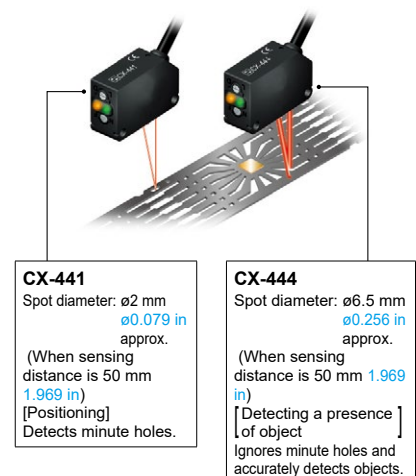

* The CX-444 supports a detection distance of up to 100 mm 3.937 in.

The bright spot makes beam axis alignment easy

CX-44□

These sensors have a high luminance red spot that provides bright visibility. The sensing position can be checked at a glance. Because the CX-441 sensor has a small spot beam, at approx. ø2 mm ø0.079 in, even the minutest object can be accurately detected.



Can be used for sensing minute differences

CX-44□

Equipped with a multirotation adjuster so that even challenging range settings can be handled with ease.

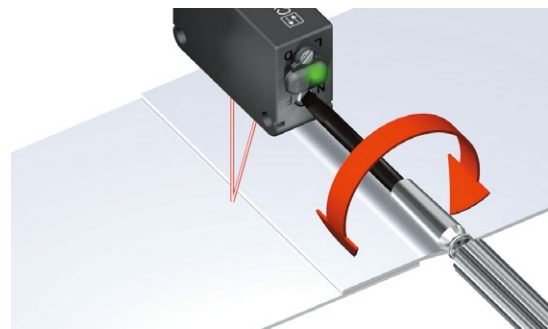

Equipped with automatic interference prevention function CX-44□

The automatic interference prevention function prevents mutual interference.

BGS / FGS functions make even the most challenging settings possible! CX-44

The BGS function is best suited for the following case

BGS **Background not present**
When object and background are separated

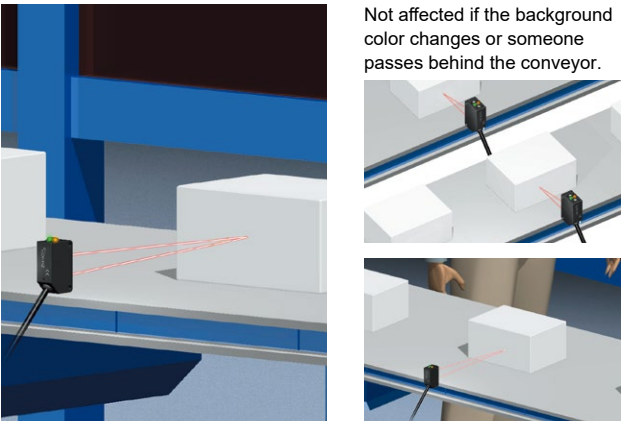

The FGS function is best suited for the following case

FGS **Background present**
When object and background are close together
When the object is glossy or uneven

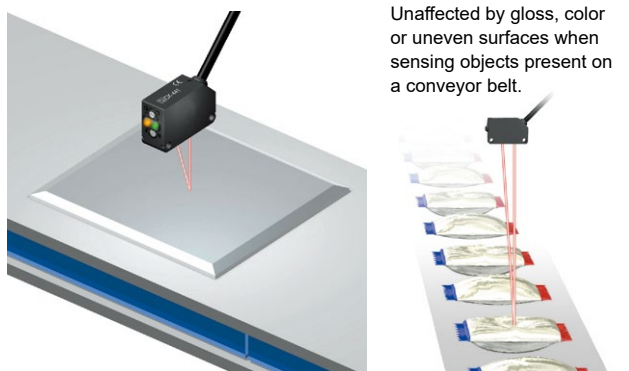

Note: Please use the FGS function together with a conveyor or other background unit.

BGS (Background suppression) function

The sensor judges that an object is present when light is received at position A of the light-receiving element (2-segment element). This is useful if the object and background are far apart. The distance adjustment method is the same as the conventional adjustment method for adjustable range reflective type sensors.

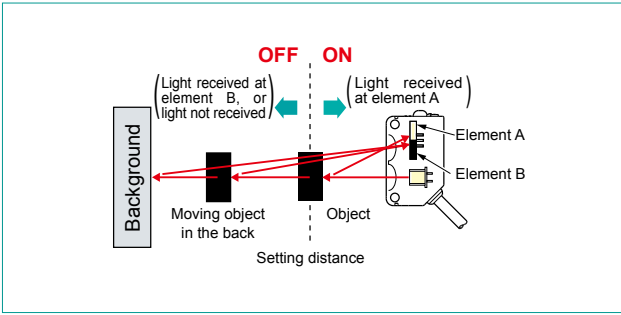

FGS (Foreground suppression) function

The sensor judges that an object is present when no light is received at position B of the light-receiving element (2-segment element). Accordingly, even objects that are glossy can be sensed. This is useful if the object and background are close together, or if the object being sensed is glossy.

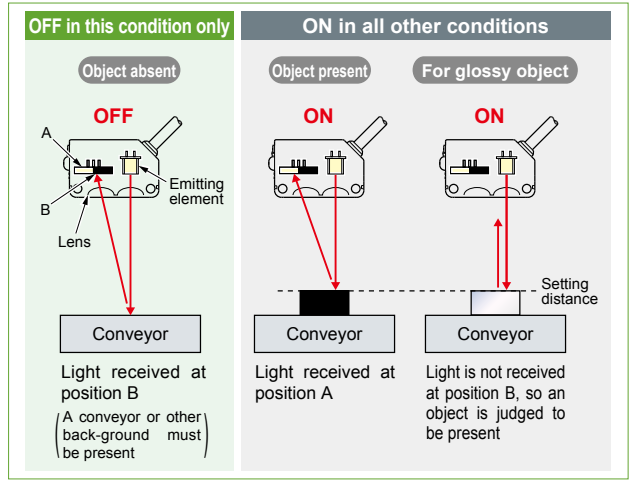

Applications

- **Small tablet detection**
Detects minute objects unaffected by glossy background objects. Uses FGS function.
- **Thin biscuit detection**
Stable sensing even for thin objects. Uses FGS function.
- **Passage confirmation**
Not affected by color variations in objects and background objects. Uses BGS function.

ORDER GUIDE

Type	Appearance	Sensing range	Model No. (Note 1)		Output operation	Emitting element
			NPN output	PNP output		
Thru-beam Long sensing range		10 m 32.808 ft	CX-411	CX-411-P	Switchable either Light-ON or Dark-ON	Red LED
		15 m 49.213 ft	CX-412	CX-412-P		Infrared LED
		30 m 98.425 ft	CX-413	CX-413-P		Infrared LED
Retroreflective With polarizing filters Long sensing range For transparent object sensing		3 m 9.843 ft (Note 2)	CX-491	CX-491-P		Red LED
		5 m 16.404 ft (Note 2)	CX-493	CX-493-P		Red LED
		50 to 500 mm 1.969 to 19.685 in (Note 2)	CX-481	CX-481-P		Infrared LED
		50 to 1,000mm 1.969 to 39.37 in (Note 2)	CX-483	CX-483-P		
Diffuse reflective Narrow-view		100 mm 3.937 in	CX-424	CX-424-P	Infrared LED	
		300 mm 11.811 in	CX-421	CX-421-P		
		800 mm 31.496 in	CX-422	CX-422-P		
		70 to 300 mm 2.756 to 11.811 in	CX-423	CX-423-P	Red LED	
Adjustable range reflective Small spot		2 to 50 mm 0.079 to 1.969 in Adjustable range: 20 to 50 mm 0.787 to 1.969 in	CX-441	CX-441-P	Switchable either Detection-ON or Detection-OFF	Red LED
		2 to 50 mm 0.079 to 1.969 in (Distance setting: 50 mm 1.969 in)	CX-444	CX-444-P		
		15 to 100 mm 0.591 to 3.937 in (Distance setting: 100 mm 3.937 in) Adjustable range: 20 to 100 mm 0.787 to 3.937 in				
		20 to 300 mm 0.787 to 11.811 in Adjustable range: 40 to 300 mm 1.575 to 11.811 in	CX-442	CX-442-P		

NOTE: Mounting bracket is not supplied with the sensor. Please select from the range of optional sensor mounting brackets.

- Notes: 1) The model No. with "E" shown on the label affixed to the thru-beam type sensor is the emitter, "D" shown on the label is the receiver.
 2) The sensing range of the retroreflective type sensor is specified for the **RF-230** reflector. The sensing range represents the actual sensing range of the sensor. The sensing ranges itemized in "A" of the table below may vary depending on the shape of sensing object. Be sure to check the operation with the actual sensing object.

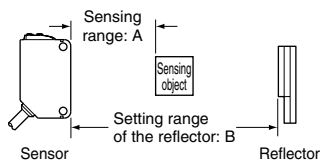

	CX-491 □	CX-493 □	CX-481 □	CX-483 □	CX-482 □
A	0 to 3 m 0 to 9.843 ft	0 to 5 m 0 to 16.404 ft	50 to 500 mm 1.969 to 19.685 in	50 to 1,000 mm 1.969 to 39.37 in	0.1 to 2 m 0.328 to 6.562 ft
B	0.1 to 3 m 0.328 to 9.843 ft	0.1 to 5 m 0.328 to 16.404 ft	100 to 500 mm 3.937 to 19.685 in	100 to 1,000 mm 3.937 to 39.37 in	0.8 to 2 m 2.625 to 6.562 ft

OPTIONS

Designation	Model No.		Slit size	Sensing range		Min. sensing object	
	Slit mask	Sensor		Slit on one side	Slit on both sides	Slit on one side	Slit on both sides
Round slit mask (For thru-beam type sensor only)	OS-CX-05	CX-411□	ø0.5 mm ø0.020 in	400 mm 15.748 in	20 mm 0.787 in	ø12 mm ø0.472 in	ø0.5 mm ø0.020 in
		CX-412□		600 mm 23.622 in	30 mm 1.181 in		
		CX-413□		1,200 mm 47.242 in	60 mm 2.362 in		
	OS-CX-1	CX-411□	ø1 mm ø0.039 in	900 mm 35.433 in	100 mm 3.937 in	ø12 mm ø0.472 in	ø1 mm ø0.039 in
		CX-412□		1.35 m 4.429 ft	150 mm 5.906 in		
		CX-413□		2.7 m 8.857 ft	300 mm 11.811 in		ø1.5 mm ø0.059 in
	OS-CX-2	CX-411□	ø2 mm ø0.079 in	2 m 6.562 ft	400 mm 15.748 in	ø12 mm ø0.472 in	ø2 mm ø0.079 in
		CX-412□		3 m 9.843 ft	600 mm 23.622 in		
		CX-413□		6 m 19.685 ft	1,200 mm 47.242 in		ø3 mm ø0.118 in
Rectangular slit mask (For thru-beam type sensor only)	OS-CX-05×6	CX-411□	0.5×6 mm 0.020×0.236 in	2 m 6.562 ft	400 mm 15.748 in	ø12 mm ø0.472 in	0.5×6 mm 0.020×0.236 in
		CX-412□		3 m 9.843 ft	600 mm 23.622 in		
		CX-413□		6 m 19.685 ft	1,200 mm 47.242 in		
	OS-CX-1×6	CX-411□	1×6 mm 0.039×0.236 in	3 m 9.843 ft	1 m 3.281 ft	ø12 mm ø0.472 in	1×6 mm 0.039×0.236 in
		CX-412□		4.5 m 14.764 ft	1.5 m 4.921 ft		
		CX-413□		9 m 29.528 ft	3 m 9.843 ft		
	OS-CX-2×6	CX-411□	2×6 mm 0.079×0.236 in	5 m 16.404 ft	2 m 6.562 ft	ø12 mm ø0.472 in	2×6 mm 0.079×0.236 in
		CX-412□		7.5 m 24.606 ft	3 m 9.843 ft		
		CX-413□		15 m 49.213 ft	6 m 19.685 ft		

Designation	Model No. (Note 1)	Direction of thru-beam axis	Color of metal	Sensing range	Min. sensing object
Interference prevention filter (For CX-411□ only) A set of emitter filter and receiver filter	PF-CX4-H	Horizontal	Light brown	5 m 16.404 ft (Note 2)	ø12 mm ø0.472 in (Note 2)
	PF-CX4-V	Vertical	Silver		

Notes: 1) The model No. is not shown on the interference prevention filters. Take care when mounting them on the sensors.
2) Value when attached on both sides.

Round slit mask

- OS-CX-□
Fitted on the front face of the sensor with one-touch.

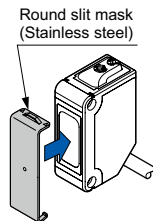

Rectangular slit mask

- OS-CX-□×6
Fitted on the front face of the sensor with one-touch.

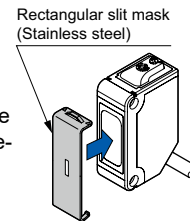

Interference prevention filter

- PF-CX4-H
(Direction of thru-beam axis: Horizontal, Color of metal: Light brown)
- PF-CX4-V
(Direction of thru-beam axis: Vertical, Color of metal: Silver)

Fitted on the front face of the sensor with one-touch.

By mounting the interference prevention filters PF-CX4-□, up to two sets of the CX-411□ can be mounted close together.

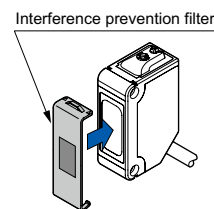
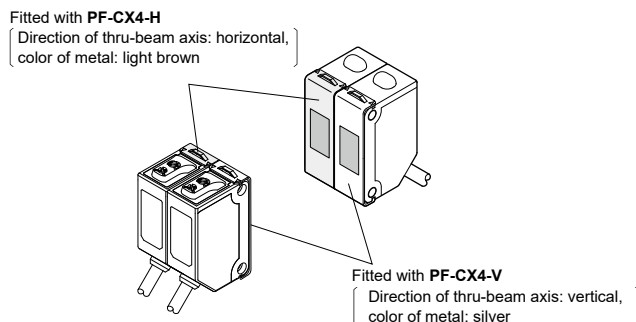

OPTIONS

Designation	Model No.	Sensor	Sensing range: A (Note 2)	Setting range of the reflector or reflective tape: B	Min. sensing object	Description
CX-493□	5 m 16.404 ft	0.1 to 5 m 0.328 to 16.404 ft				
CX-481□	50 to 500 mm 1.969 to 19.685 in	100 to 500 mm 3.937 to 19.685 in				
CX-482□	0.1 to 2 m 0.328 to 6.562 ft	0.8 to 2 m 2.625 to 6.562 ft				
CX-483□	0.05 to 1 m 0.164 to 3.281 ft	0.1 to 1 m 0.328 to 3.281 ft				
RF-210	CX-491□	1 m 3.281 ft	0.1 to 1 m 0.328 to 3.281 ft	ø30 mm ø1.181 in	<ul style="list-style-type: none"> Dimensions: W33.3 × H12.8 × D11 mm W1.311 × H0.504 × D0.433 in Mounting hole: ø3.4 mm ø0.134 in 	
	CX-493□	1.5 m 4.921 ft	0.1 to 1.5 m 0.328 to 4.921 ft			
	CX-481□	—	—			
	CX-482□	0.1 to 0.6 m 0.328 to 1.969 ft	0.3 to 0.6 m 0.984 to 1.969 ft			
	CX-483□	0.1 to 0.3 m 0.328 to 0.984 ft	0.1 to 0.3 m 0.328 to 0.984 ft			
RF-220	CX-491□	1.5 m 4.921 ft	0.1 to 1.5 m 0.328 to 4.921 ft	ø35 mm ø1.378 in	<ul style="list-style-type: none"> Dimensions: W35.3 × H42.3 × D8.3 mm W1.390 × H1.665 × D0.327 in Mounting hole: ø3.6 mm ø0.142 in 	
	CX-493□	3 m 9.843 ft	0.1 to 3 m 0.328 to 9.843 ft			
	CX-481□	50 to 300 mm 1.969 to 11.811 in	100 to 300 mm 3.937 to 11.811 in			
	CX-482□	0.1 to 1.3 m 0.328 to 4.265 ft	0.5 to 1.3 m 1.64 to 4.265 ft			
	CX-483□	0.1 to 0.7 m 0.328 to 2.297 ft	0.2 to 0.7 m 0.656 to 2.297 ft			
Reflective tape (Note 1) (For retroreflective type sensor only)	RF-11 (Note 3)	CX-491□	0.5 m 1.640 ft	0.1 to 0.5 m 0.328 to 1.640 ft	ø30 mm ø1.181 in	<ul style="list-style-type: none"> Dimensions: W30 × H8 × D0.7 mm W1.181 × H0.315 × D0.028 in Ambient temperature: -25 to +50 °C -13 to +122 °F Ambient humidity: 35 to 85% RH
		CX-493□	0.8 m 2.625 ft	0.1 to 0.8 m 0.328 to 2.625 ft		
		CX-481□	—	—		
		CX-482□	—	—		
		CX-483□	—	—		
	RF-12 (Note 3)	CX-491□	0.7 m 2.297 ft	0.1 to 0.7 m 0.328 to 2.297 ft	ø30 mm ø1.181 in	<ul style="list-style-type: none"> Dimensions: W30 × H25 × D0.7 mm W1.181 × H0.984 × D0.028 in Ambient temperature: -25 to +50 °C -13 to +122 °F Ambient humidity: 35 to 85% RH
		CX-493□	1.2 m 3.937 ft	0.1 to 1.2 m 0.328 to 3.937 ft		
		CX-481□	—	—		
		CX-482□	0.1 to 0.6 m 0.328 to 1.969 ft	0.4 to 0.6 m 1.312 to 1.969 ft		
		CX-483□	—	—		
	RF-13	CX-491□	0.5 m 1.64 ft	0.2 to 0.5 m 0.656 to 1.64 ft	ø30 mm ø1.181 in	<ul style="list-style-type: none"> Dimensions: W30 × H30 × D0.5 mm W1.181 × H1.181 × D0.020 in Ambient temperature: -25 to +55 °C -13 to +131 °F Ambient humidity: 35 to 85% RH
		CX-493□	—	—		
		CX-481□	—	—		
		CX-482□	—	—		
		CX-483□	—	—		

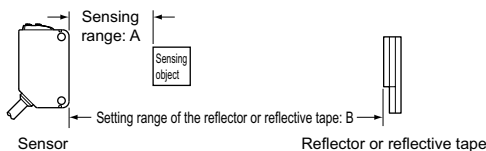

- Notes
- 1) Be sure to align the beam axis when mounting the sensor and reflector or reflective tape. Use of the **RF-210** reflector or **RF-11** reflective tape requires more precise adjustment than when the **RF-230** reflector supplied with the product is used. Mount the reflector / reflective tape in such a way that the sensor angle can be adjusted in a wide range. For the sensor angle adjustment and reflector / reflective tape position adjustment, refer to "PRECAUTIONS FOR PROPER USE" on pages 20 and 21.
 - 2) Sensing range A may vary depending on the shape of the sensing object. Be sure to check the operation with the actual sensing object.
 - 3) Do not press the reflective tape **RF-11** and **RF-12** strongly because they have soft surfaces. The internal prism may be crushed and the reflection distance may be reduced. Also, do not cut the tape before use. Performance will not be maintained.

Reflector

• RF-230

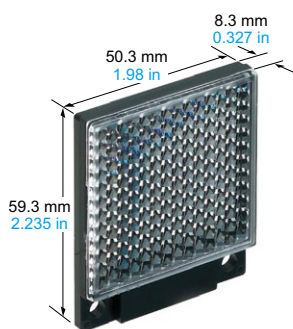

• RF-210

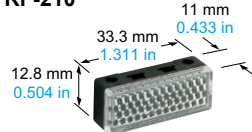

• RF-220



Reflective tape

• RF-11

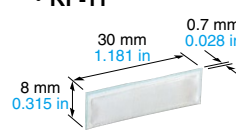

• RF-12

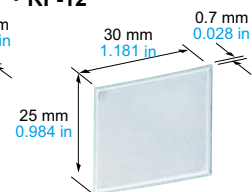

• RF-13

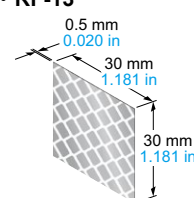

Designation	Model No.	Description
Reflector mounting bracket	MS-RF21-1	Protective mounting bracket for RF-210 It protects the reflector from damage and maintains alignment.
	MS-RF22	For RF-220
	MS-RF23	For RF-230
Sensor mounting bracket (Note)	MS-CX2-1	Foot angled mounting bracket It can also be used for mounting RF-210 .
	MS-CX2-2	Foot biangled mounting bracket It can also be used for mounting RF-210 .
	MS-CX2-4	Protective mounting bracket
	MS-CX2-5	Back biangled mounting bracket
	MS-CX-3	Back angled mounting bracket
Universal sensor mounting stand	MS-AJ1	Horizontal mounting type
	MS-AJ2	Vertical mounting type
	MS-AJ1-A	Horizontal mounting type
	MS-AJ2-A	Vertical mounting type
	MS-AJ1-M	Horizontal mounting type
	MS-AJ2-M	Vertical mounting type

Note: The plug-in connector type sensor does not allow use of some sensor mounting brackets because of the protrusion of the connector.

Reflector mounting bracket

• **MS-RF21-1**

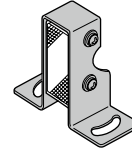

Two M3 (length 12 mm 0.472 in) screws with washers are attached.

• **MS-RF22**

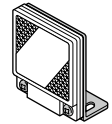

Two M3 (length 8 mm 0.315 in) screws with washers are attached.

• **MS-RF23**

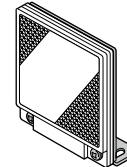

Two M4 (length 10 mm 0.394 in) screws with washers are attached.

Sensor mounting bracket

• **MS-CX2-1**

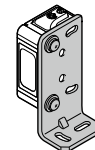

Two M3 (length 12 mm 0.472 in) screws with washers are attached.

• **MS-CX2-2**

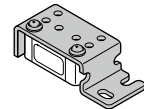

Two M3 (length 12 mm 0.472 in) screws with washers are attached.

• **MS-CX2-4**

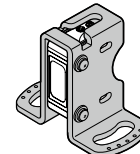

Two M3 (length 14 mm 0.551 in) screws with washers are attached.

• **MS-CX2-5**

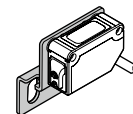

Two M3 (length 12 mm 0.472 in) screws with washers are attached.

• **MS-CX-3**

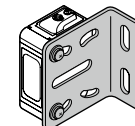

Two M3 (length 12 mm 0.472 in) screws with washers are attached.

Universal sensor mounting stand

• **MS-AJ1**

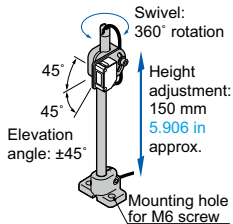

• **MS-AJ1-A**

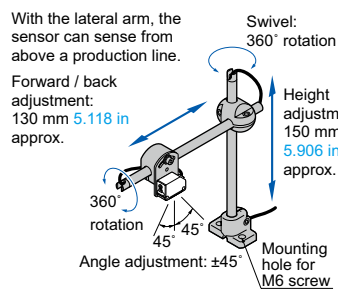

• **MS-AJ1-M**

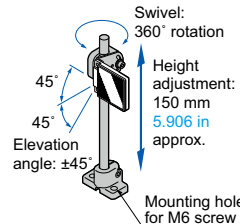

• **MS-AJ2**

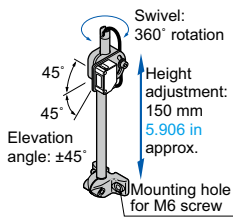

• **MS-AJ2-A**

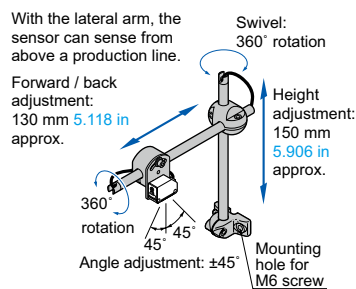

• **MS-AJ2-M**

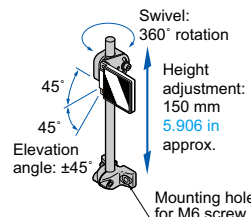

SPECIFICATIONS

Item	Model No.	Type	Thru-beam			Retroreflective					Diffuse reflective			
			Long sensing range			With polarizing filters	Long sensing range	For transparent object sensing						Narrow-view
			CX-411	CX-412	CX-413	CX-491	CX-493	CX-481	CX-483	CX-482	CX-424	CX-421	CX-422	CX-423
Applicable regulations and certifications	CE Marking (EMC Directive, RoHS Directive), UKCA Marking (EMC Regulations, RoHS Regulations), UL Recognition													
Sensing range	10 m 32.808 ft	15 m 49.213 ft	30 m 98.425 ft	3 m 9.843 ft (Note 2)	5 m 16.404 ft (Note 2)	50 to 500 mm 1.969 to 19.685 in (Note 2)	50 to 1,000 mm 1.969 to 39.37 in (Note 2)	0.1 to 2 m 0.328 to 6.562 ft (Note 2)	100 mm 3.937 in (Note 3)	300 mm 11.811 in (Note 3)	800 mm 31.496 in (Note 3)	70 to 300 mm 2.756 to 11.811 in (Note 3)		
Sensing object	ø12 mm ø0.472 in or more opaque object (Note 4)			ø50 mm ø1.969 in or more opaque, translucent or specular object (Note 2, 5)	ø50 mm ø1.969 in or more opaque or translucent object (Note 2, 5)	ø50 mm ø1.969 in or more transparent, translucent or opaque object (Note 2, 5)			Opaque, translucent or transparent object (Note 5)			Opaque, translucent or transparent object (Note 5) (Min. sensing object: ø0.5 mm ø0.020 in copper wire)		
Hysteresis	—								15 % or less of operation distance (Note 3)					
Repeatability (perpendicular to sensing axis)	0.5 mm 0.020 in or less								1 mm 0.039 in or less			0.5 mm 0.020 in or less		
Supply voltage	12 to 24 V DC ±10 % Ripple P-P 10 % or less													
Current consumption	Emitter: 15 mA or less Receiver: 10 mA or less	Emitter: 20 mA or less Receiver: 10 mA or less	Emitter: 25 mA or less Receiver: 10 mA or less	13 mA or less	10 mA or less				13 mA or less		15 mA or less			
Output	<p><NPN output type> NPN open-collector transistor</p> <ul style="list-style-type: none"> Maximum sink current: 100 mA Applied voltage: 30 V DC or less (between output and 0 V) Residual voltage: 2 V or less (at 100 mA sink current) 1 V or less (at 16 mA sink current) 						<p><PNP output type> PNP open-collector transistor</p> <ul style="list-style-type: none"> Maximum source current: 100 mA Applied voltage: 30 V DC or less (between output and +V) Residual voltage: 2 V or less (at 100 mA source current) 1 V or less (at 16 mA source current) 							
Output operation	Switchable either Light-ON or Dark-ON													
Short-circuit protection	Incorporated													
Response time	1 ms or less		2 ms or less		1 ms or less									
Operation indicator	Orange LED (lights up when the output is ON)(incorporated on the receiver for thru-beam type)													
Stability indicator	Green LED (lights up under stable light received condition or stable dark condition)(incorporated on the receiver for thru-beam type)													
Power indicator	Green LED (lights up when the power is ON) (incorporated on the emitter)				—									
Sensitivity adjuster	Continuously variable adjuster (incorporated on the receiver for thru-beam type)													
Automatic interference prevention function	Two units of sensors can be mounted close together with interference prevention filters. (Sensing range: 5 m 16.404 ft)			Incorporated (Two units of sensors can be mounted close together.)										
Environmental resistance	Protection	IP67 (IEC)												
	Ambient temperature	-25 to +55 °C -13 to +131 °F (No dew condensation or icing allowed), Storage: -30 to +70 °C -22 to +158 °F												
	Ambient humidity	35 to 85 % RH, Storage: 35 to 85 % RH												
	Ambient illuminance	Incandescent light: 3,000 lx at the light-receiving face												
	Voltage withstandability	1,000 V AC for one min. between all supply terminals connected together and enclosure												
	Insulation resistance	20 MΩ, or more, with 250 V DC megger between all supply terminals connected together and enclosure												
	Vibration resistance	10 to 500 Hz frequency, 1.5 mm 0.059 in double amplitude (10 G max.) in X, Y and Z directions for two hours each												
Shock resistance	500 m/s ² acceleration (50 G approx.) in X, Y and Z directions three times each													
Emitting element (modulated)	Red LED	Infrared LED		Red LED		Infrared LED		Infrared LED		Red LED				
	Peak emission wavelength	680 nm 0.027 mil	870 nm 0.034 mil	850 nm 0.033 mil	680 nm 0.027 mil	650 nm 0.026 mil	870 nm 0.034 mil		860 nm 0.033 mil		645 nm 0.025 mil			
Material	Enclosure: PBT (Polybutylene terephthalate), Lens: Acrylic (CX-48□: Polycarbonate), Indicator cover: Acrylic (CX-48□: Polycarbonate)													
Cable	0.2 mm ² 3-core (thru-beam type emitter: 2-core) cabtyre cable, 2 m 6.562 ft long													
Cable extension	Extension up to total 100 m 328.084 ft is possible with 0.3 mm ² , or more, cable (thru-beam type: both emitter and receiver)													
Weight	Net	Emitter: 45 g approx., Receiver: 50 g approx.				50 g approx.				60 g approx.				
	Gross	100 g approx.				80 g approx.				60 g approx.				
Accessories	RF-230 (Reflector): 1 pc.													

Notes: 1) Where measurement conditions have not been specified precisely, the conditions used were an ambient temperature of +23 °C +73.4 °F.
 2) The sensing range and the sensing object of the retroreflective type sensor are specified for the RF-230 reflector. The sensing range represents the actual sensing range of the sensor. The sensing range: A of the table below may vary depending on the shape of sensing object. Be sure to check the operation with the actual sensing object.

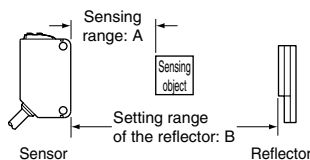

	CX-491□	CX-493□	CX-481□	CX-483□	CX-482□
A	0 to 3 m 0 to 9.843 ft	0 to 5 m 0 to 16.404 ft	50 to 500 mm 1.969 to 19.685 in	50 to 1,000 mm 1.969 to 39.37 in	0.1 to 2 m 0.328 to 6.562 ft
B	0.1 to 3 m 0.328 to 9.843 ft	0.1 to 5 m 0.328 to 16.404 ft	100 to 500 mm 3.937 to 19.685 in	100 to 1,000 mm 3.937 to 39.37 in	0.8 to 2 m 2.625 to 6.562 ft

3) The sensing range and hysteresis of the diffuse reflective type sensor are specified for white non-glossy paper (200 × 200 mm 7.874 × 7.874 in) as the object.
 4) If slit masks (optional) are fitted, an object of ø0.5 mm ø0.020 in (using round slit mask) can be detected.
 5) Make sure to confirm detection with an actual sensor before use.

SPECIFICATIONS

Item	Model No.	Type	Adjustable range reflective		
			Small spot		
		NPN output	CX-441	CX-444	CX-442
		PNP output	CX-441-P	CX-444-P	CX-442-P
Applicable regulations and certifications		CE Marking (EMC Directive, RoHS Directive), UKCA Marking (EMC Regulations, RoHS Regulations), UL Recognition			
Adjustable range (Note 2)		20 to 50 mm 0.787 to 1.969 in	20 to 100 mm 0.787 to 3.937 in	40 to 300 mm 1.575 to 11.811 in	
Sensing range (with white non-glossy paper)		2 to 50 mm 0.079 to 1.969 in	2 to 50 mm 0.079 to 1.969 in (Distance setting: 50 mm 1.969 in) 15 to 100 mm 0.591 to 3.937 in (Distance setting: 100 mm 3.937 in)	20 to 300 mm 0.787 to 11.811 in	
Hysteresis (with white non-glossy paper)		2 % or less of operation distance		5 % or less of operation distance	
Repeatability		Along sensing axis: 1 mm 0.039 in or less, Perpendicular to sensing axis: 0.2 mm 0.008 in or less (with white non-glossy paper)			
Supply voltage		12 to 24 V DC $\pm 10\%$ Ripple P-P 10 % or less			
Current consumption		20 mA or less			
Output		<NPN output type> NPN open-collector transistor		<PNP output type> PNP open-collector transistor	
		<ul style="list-style-type: none"> Maximum sink current: 100 mA Applied voltage: 30 V DC or less (between output and 0 V) Residual voltage: 2 V or less (at 100 mA sink current) 1 V or less (at 16 mA sink current) 		<ul style="list-style-type: none"> Maximum source current: 100 mA Applied voltage: 30 V DC or less (between output and +V) Residual voltage: 2 V or less (at 100 mA source current) 1 V or less (at 16 mA source current) 	
Output operation		Switchable either Detection-ON or Detection-OFF			
Short-circuit protection		Incorporated			
Response time		1 ms or less			
Operation indicator		Orange LED (lights up when the output is ON)			
Stability indicator		Green LED (lights up under stable operating condition) (Note 3)			
Distance adjuster		Multirotation mechanical adjuster			
Sensing mode		BGS / FGS functions Switchable with wiring of sensing mode selection input			
Automatic interference prevention function (Note 4)		Incorporated			
Protection		IP67 (IEC)			
Environmental resistance	Ambient temperature	-25 to +55 °C -13 to +131 °F (No dew condensation or icing allowed), Storage: -30 to +70 °C -22 to +158 °F			
	Ambient humidity	35 to 85 % RH, Storage: 35 to 85 % RH			
	Ambient illuminance	Incandescent light: 3,000 lx at the light-receiving face			
	Voltage withstandability	1,000 V AC for one min. between all supply terminals connected together and enclosure			
	Insulation resistance	20 M Ω , or more, with 250 V DC megger between all supply terminals connected together and enclosure			
	Vibration resistance	10 to 500 Hz frequency, 3 mm 0.118 in double amplitude (20 G max.) in X, Y and Z directions for two hours each			
	Shock resistance	500 m/s ² acceleration (50 G approx.) in X, Y and Z directions three times each			
Emitting element		Red LED (Peak emission wavelength: 650 nm 0.026 mil , modulated)			
Spot diameter		$\varnothing 2$ mm $\varnothing 0.079$ in approx. (at 50 mm 1.969 in distance)	$\varnothing 9$ mm $\varnothing 0.354$ in approx. (at 100 mm 3.937 in distance)	$\square 15$ mm $\square 0.591$ in approx. (at 300 mm 11.811 in distance)	
Material		Enclosure: PBT (Polybutylene terephthalate), Lens: Polycarbonate, Indicator cover: Polycarbonate			
Cable		0.2 mm ² 4-core cabtyre cable, 2 m 6.562 ft long			
Cable extension		Extension up to total 100 m 328.084 ft is possible with 0.3 mm ² , or more, cable.			
Weight		Net weight: 55 g approx., Gross weight: 65 g approx.			

- Notes: 1) Where measurement conditions have not been specified precisely, the conditions used were an ambient temperature of +23 °C **+73.4 °F**.
 2) The adjustable range stands for the maximum sensing range which can be set with the distance adjuster. The sensor can detect an object 2 mm **0.079 in** [CX-444(-P)]: 15 mm **0.591 in**, CX-442(-P): 20 mm **0.787 in**], or more, away.

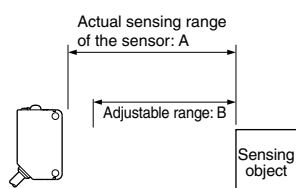

	CX-441□	CX-444□		CX-442□
A	2 to 50 mm 0.079 to 1.969 in	2 to 50 mm 0.079 to 1.969 in	15 to 100 mm 0.591 to 3.937 in	20 to 300 mm 0.787 to 11.811 in
B	20 to 50 mm 0.787 to 1.969 in	20 to 50 mm 0.787 to 1.969 in	50 to 100 mm 1.969 to 3.937 in	40 to 300 mm 1.575 to 11.811 in

- 3) Refer to the "Stability indicator (p.23)" of "PRECAUTIONS FOR PROPER USE" for operation of the stability indicator.
 4) Note that detection may be unstable depending on the mounting conditions or the sensing object. In the state that this product is mounted, be sure to check the operation with the actual sensing object.

I/O CIRCUIT AND WIRING DIAGRAMS

NPN output type

I/O circuit diagram

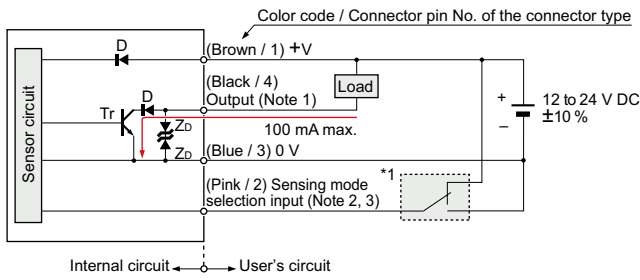

- Notes: 1) The emitter of the thru-beam type sensor does not incorporate the output.
 2) Sensing mode selection input is incorporated only for the **CX-44** adjustable range reflective type. When using the **CX-44**, be sure to wire the sensing mode selection input (pink / 2) as mentioned *1. Unstable operation may occur.
 3) When the mating cable is connected to the plug-in connector type of **CX-44**, its color is white.

*1

- Sensing mode selection input
 BGS function: Connect to 0 V
 FGS function: Connect to +V

Symbols ... D : Reverse supply polarity protection diode
 Z_D : Surge absorption zener diode
 Tr : NPN output transistor

Wiring diagram

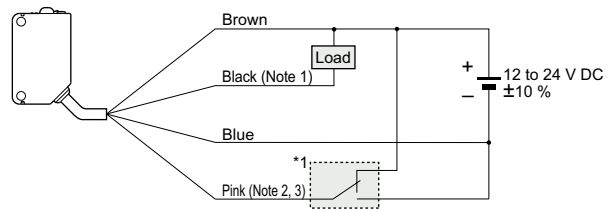

- Notes: 1) The emitter of the thru-beam type sensor does not incorporate the black wire.
 2) The pink wire is incorporated only for the **CX-44** adjustable range reflective type. When using the **CX-44**, be sure to wire the pink wire as mentioned *1. Unstable operation may occur.
 3) When the mating cable is connected to the plug-in connector type of **CX-44**, its color is white.

*1

- Sensing mode selection input
 BGS function: Connect to 0 V
 FGS function: Connect to +V

Connector pin position

M8 plug-in connector type

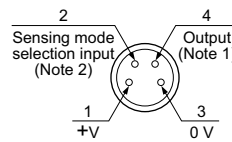

M12 pigtailed type

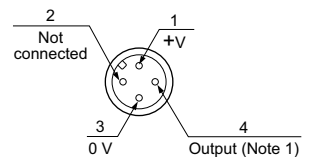

- Notes: 1) The emitter of the thru-beam type sensor does not incorporate the output.
 2) Sensing mode selection input is incorporated only for the **CX-44** adjustable range reflective type. When using the **CX-44**, be sure to wire the sensing mode selection input (pink / 2). Unstable operation may occur.

PNP output type

I/O circuit diagram

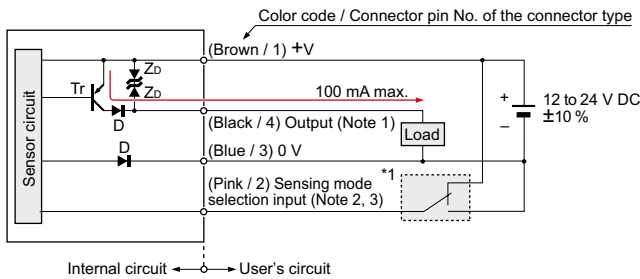

- Notes: 1) The emitter of the thru-beam type sensor does not incorporate the output.
 2) Sensing mode selection input is incorporated only for the **CX-44-P** adjustable range reflective type. When using the **CX-44-P**, be sure to wire the sensing mode selection input (pink / 2) as mentioned *1. Unstable operation may occur.
 3) When the mating cable is connected to the plug-in connector type of **CX-44-P**, its color is white.

*1

- Sensing mode selection input
 BGS function: Connect to 0 V
 FGS function: Connect to +V

Symbols ... D : Reverse supply polarity protection diode
 Z_D : Surge absorption zener diode
 Tr : PNP output transistor

Wiring diagram

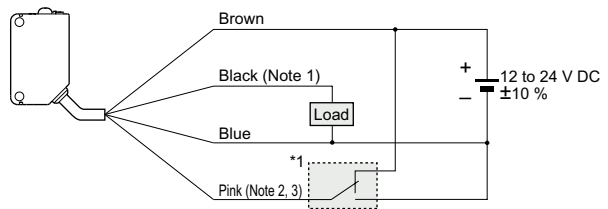

- Notes: 1) The emitter of the thru-beam type sensor does not incorporate the black wire.
 2) The pink wire is incorporated only for the **CX-44-P** adjustable range reflective type. When using the **CX-44-P**, be sure to wire the pink wire as mentioned *1. Unstable operation may occur.
 3) When the mating cable is connected to the plug-in connector type of **CX-44-P**, its color is white.

*1

- Sensing mode selection input
 BGS function: Connect to 0 V
 FGS function: Connect to +V

Connector pin position

M8 plug-in connector type

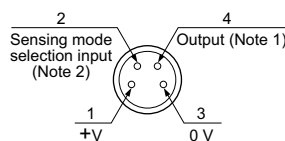

M12 pigtailed type

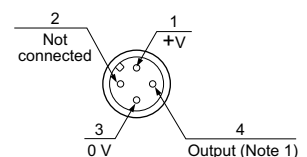

- Notes: 1) The emitter of the thru-beam type sensor does not incorporate the output.
 2) Sensing mode selection input is incorporated only for the **CX-44-P** adjustable range reflective type. When using the **CX-44-P**, be sure to wire the sensing mode selection input (pink / 2). Unstable operation may occur.

CX-411□

Thru-beam type

Parallel deviation

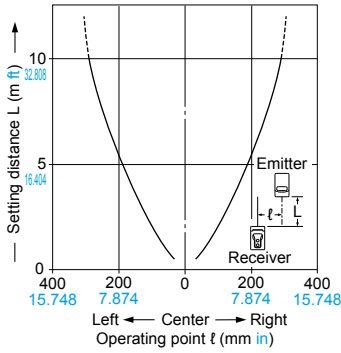

Angular deviation

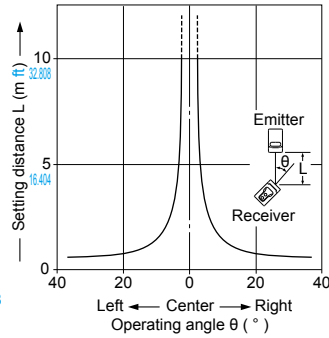

Parallel deviation with round slit masks (ø0.5 mm ø0.020 in)

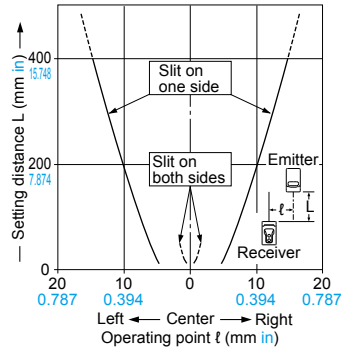

Parallel deviation with round slit masks (ø1 mm ø0.039 in)

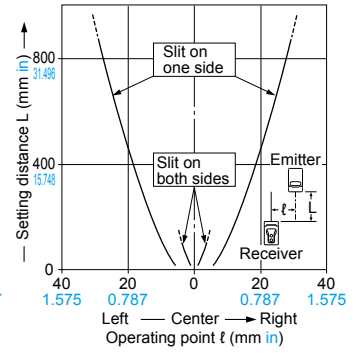

Parallel deviation with round slit masks (ø2 mm ø0.079 in)

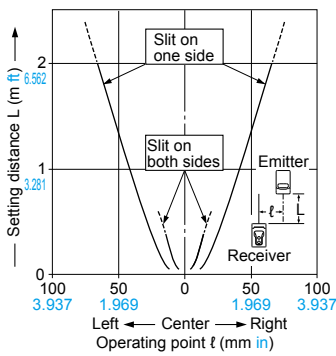

Parallel deviation with rectangular slit masks (0.5 × 6 mm 0.020 × 0.236 in)

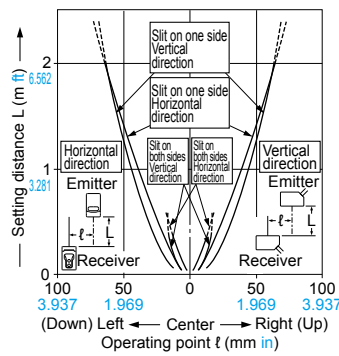

Parallel deviation with rectangular slit masks (1 × 6 mm 0.039 × 0.236 in)

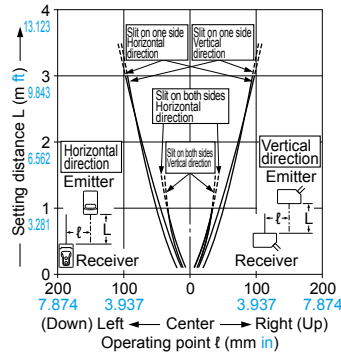

Parallel deviation with rectangular slit masks (2 × 6 mm 0.079 × 0.236 in)

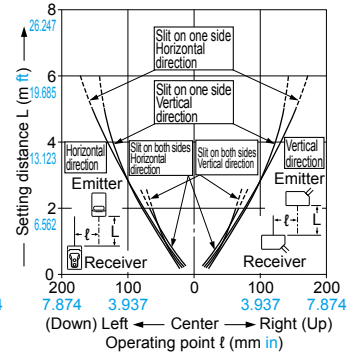

Parallel deviation with interference prevention filters (PF-CX4-V) on both sides

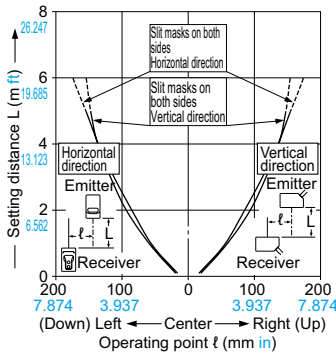

CX-412 □

Thru-beam type

Parallel deviation

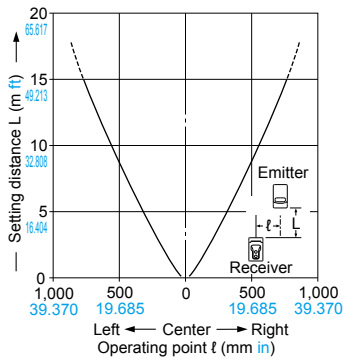

Angular deviation

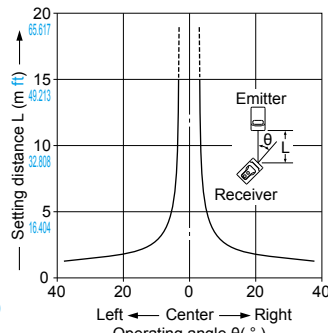

Parallel deviation with round slit masks (ø0.5 mm ø0.020 in)

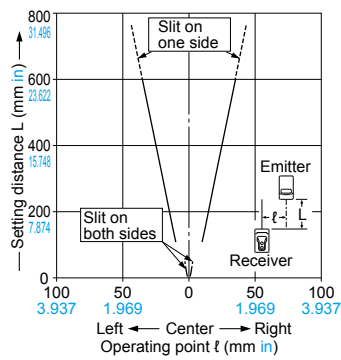

Parallel deviation with round slit masks (ø1 mm ø0.039 in)

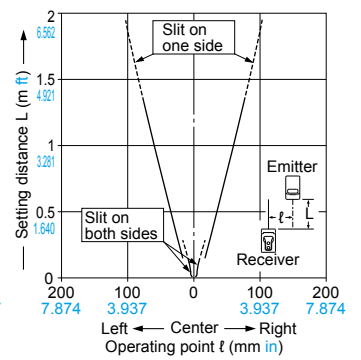

Parallel deviation with round slit masks (ø2 mm ø0.079 in)

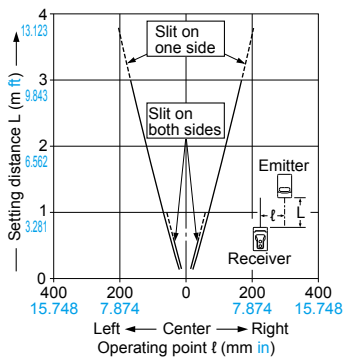

Parallel deviation with rectangular slit masks (0.5 x 6 mm 0.020 x 0.236 in)

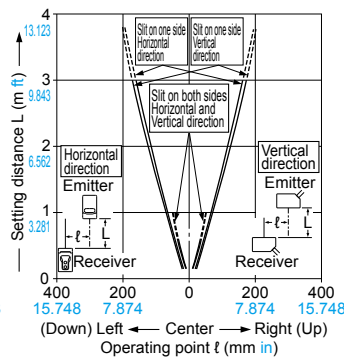

Parallel deviation with rectangular slit masks (1 x 6 mm 0.039 x 0.236 in)

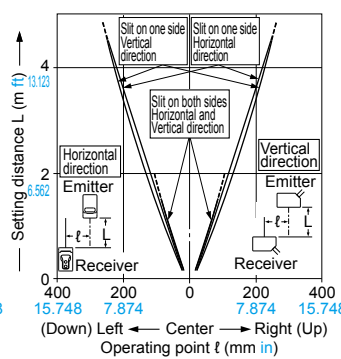

Parallel deviation with rectangular slit masks (2 x 6 mm 0.079 x 0.236 in)

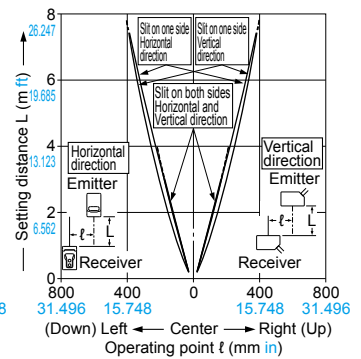

CX-491 □

Retroreflective type

Parallel deviation

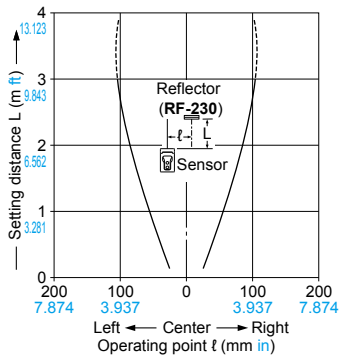

Angular deviation

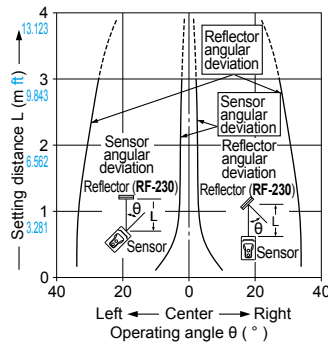

Parallel deviation

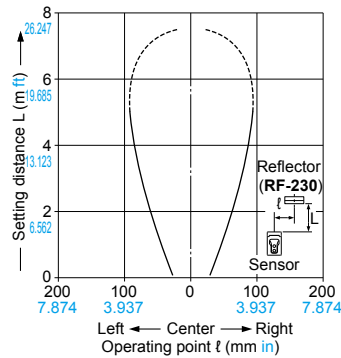

Angular deviation

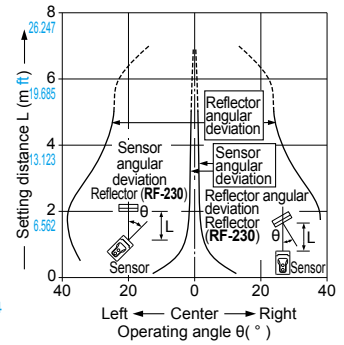

CX-481 □

Retroreflective type

Parallel deviation

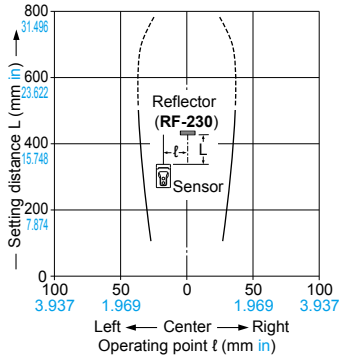

Angular deviation

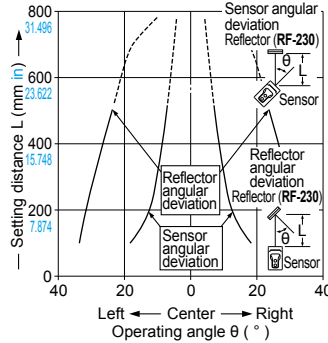

Parallel deviation

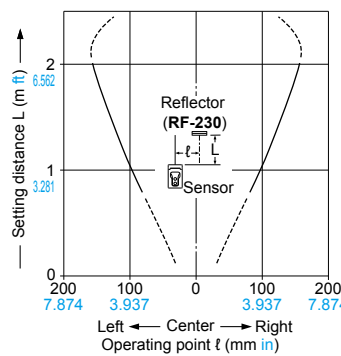

Angular deviation

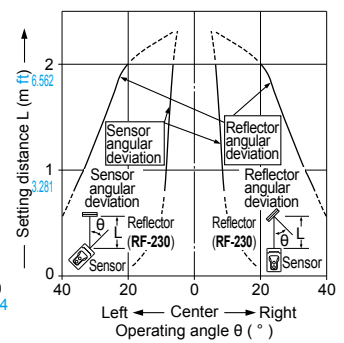

SENSING CHARACTERISTICS (TYPICAL)

CX-424 □

Diffuse reflective type

Sensing field

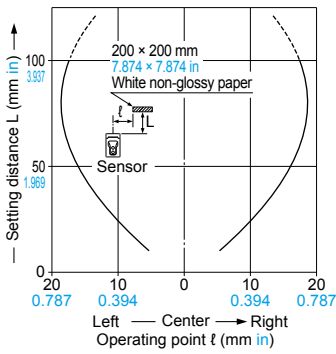

Correlation between sensing object size and sensing range

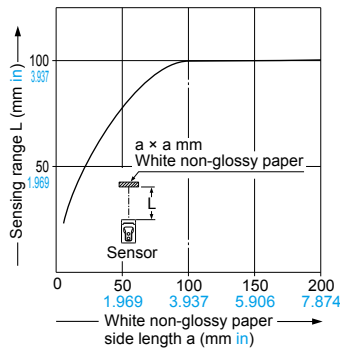

As the sensing object size becomes smaller than the standard size (white non-glossy paper 200 × 200 mm 7.874 × 7.874 in), the sensing range shortens, as shown in the left graph.

(For plotting the left graph, the sensitivity has been set such that a 200 × 200 mm 7.874 × 7.874 in white non-glossy paper is just detectable at a distance of 100 mm 3.937 in.)

CX-421 □

Diffuse reflective type

Sensing field

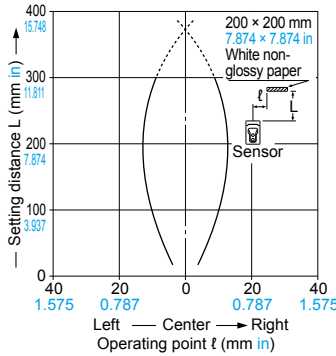

Correlation between sensing object size and sensing range

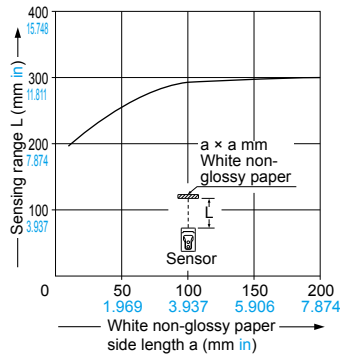

As the sensing object size becomes smaller than the standard size (white non-glossy paper 200 × 200 mm 7.874 × 7.874 in), the sensing range shortens, as shown in the left graph.

(For plotting the left graph, the sensitivity has been set such that a 200 × 200 mm 7.874 × 7.874 in white non-glossy paper is just detectable at a distance of 300 mm 11.811 in.)

CX-422 □

Diffuse reflective type

Sensing field

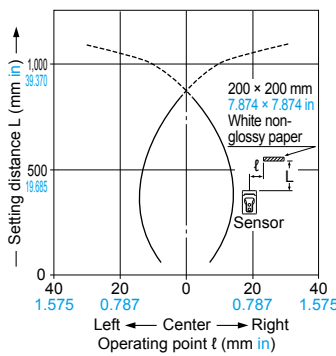

Correlation between sensing object size and sensing range

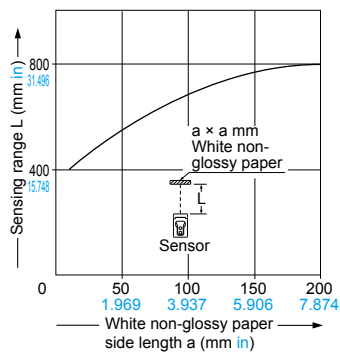

As the sensing object size becomes smaller than the standard size (white non-glossy paper 200 × 200 mm 7.874 × 7.874 in), the sensing range shortens, as shown in the left graph.

(For plotting the left graph, the sensitivity has been set such that a 200 × 200 mm 7.874 × 7.874 in white non-glossy paper is just detectable at a distance of 800 mm 31.496 in.)

SENSING CHARACTERISTICS (TYPICAL)

CX-423□

Diffuse reflective type

Sensing field

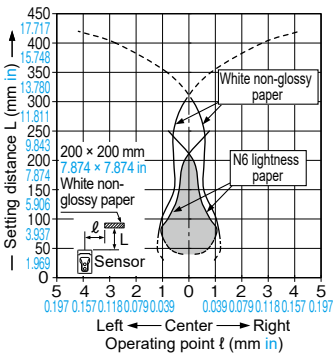

Correlation between sensing object size and sensing range

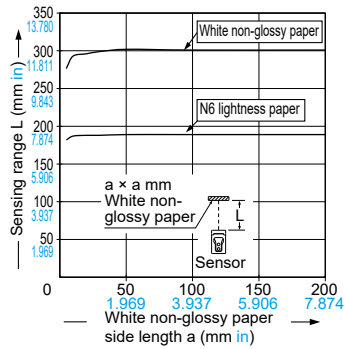

As the sensing object size becomes smaller than the standard size (white non-glossy paper 200 × 200 mm 7.874 × 7.874 in), the sensing range shortens, as shown in the left graph.

(For plotting the left graph, the sensitivity has been set such that a 200 × 200 mm 7.874 × 7.874 in white non-glossy paper is just detectable at a distance of 200 mm 7.874 in. Contact us for the sensing characteristics of 300 mm 11.811 in distance. Please contact us for the sensing field at the setting distance 300 mm 11.811 in.)

Correlation between lightness and sensing range

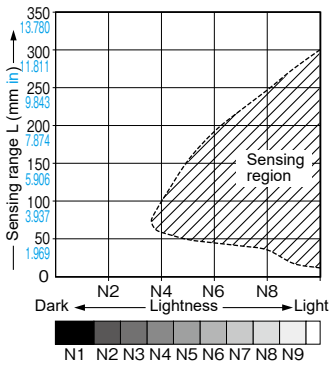

The sensing region is represented by oblique lines in the left figure. However, the sensitivity should be set with an enough margin because of slight variation in products.

(Lightness shown on the left may differ slightly from the actual object condition.)

Emitted beam

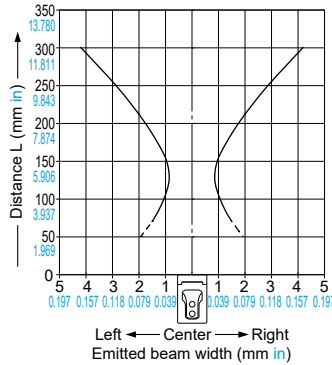

CX-441□

Adjustable range reflective type

Sensing fields

• Setting distance: 25 mm 0.984 in

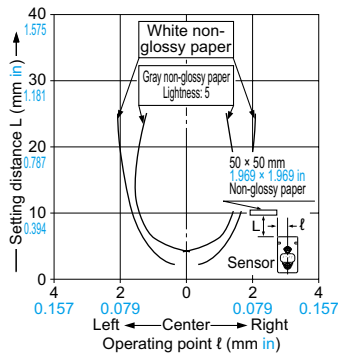

• Setting distance: 50 mm 1.969 in

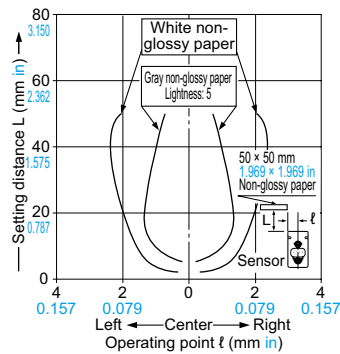

Emitted beam

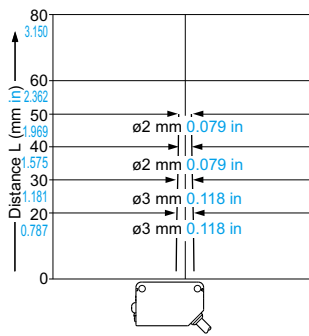

Correlation between color (50 × 50 mm 1.969 × 1.969 in construction paper) and sensing range

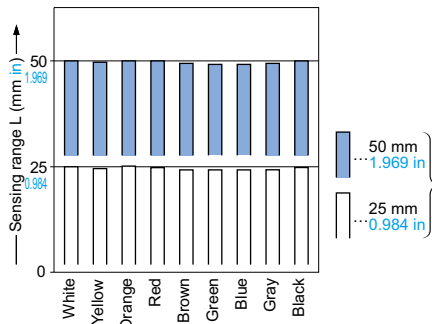

These bars indicate the sensing range with the respective colors when the distance adjuster is set to a sensing range of 50 mm 1.969 in and 25 mm 0.984 in long, respectively, with white color.

The sensing range also varies depending on material.

Correlation between material (50 × 50 mm 1.969 × 1.969 in) and sensing range

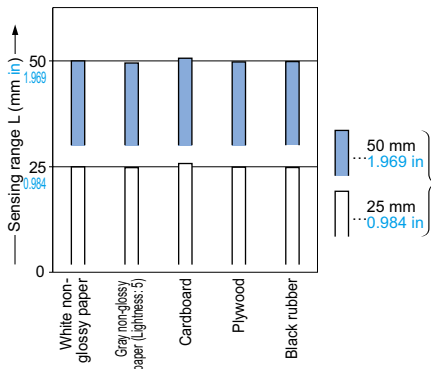

These bars indicate the sensing range with the respective objects when the distance adjuster is set to a sensing range of 50 mm 1.969 in and 25 mm 0.984 in long, respectively, with white non-glossy paper.

SENSING CHARACTERISTICS (TYPICAL)

CX-444□

Adjustable range reflective type

Sensing fields

- Setting distance: 25 mm 0.984 in
- Setting distance: 50 mm 1.969 in
- Setting distance: 100 mm 3.937 in

Emitted beam

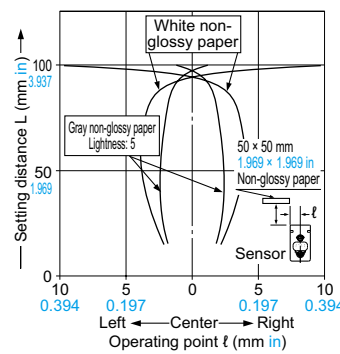
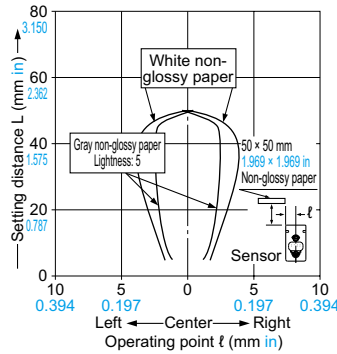
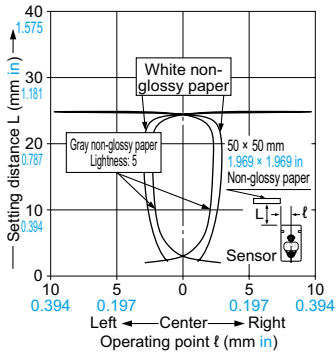
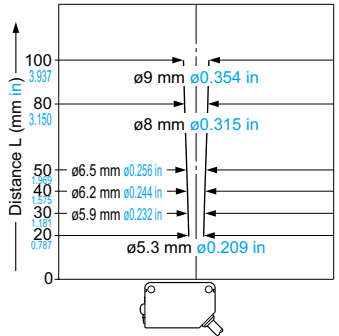

Correlation between color (50 × 50 mm 1.969 × 1.969 in construction paper) and sensing range

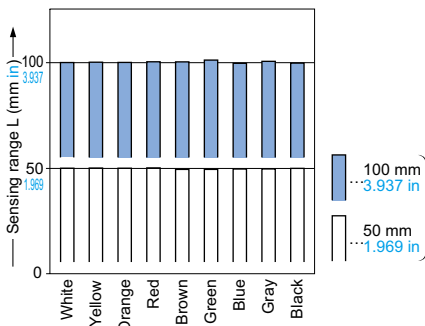

These bars indicate the sensing range with the respective colors when the distance adjuster is set to a sensing range of 100 mm 3.937 in and 50 mm 1.969 in long, respectively, with white color. The sensing range also varies depending on material.

Correlation between material (50 × 50 mm 1.969 × 1.969 in) and sensing range

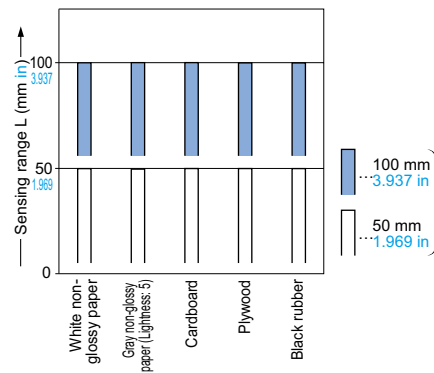

These bars indicate the sensing range with the respective objects when the distance adjuster is set to a sensing range of 100 mm 3.937 in and 50 mm 1.969 in long, respectively, with white non-glossy paper.

CX-442□

Adjustable range reflective type

Sensing fields

- Setting distance: 100 mm 3.937 in
- Setting distance: 200 mm 7.874 in
- Setting distance: 300 mm 11.811 in

Emitted beam

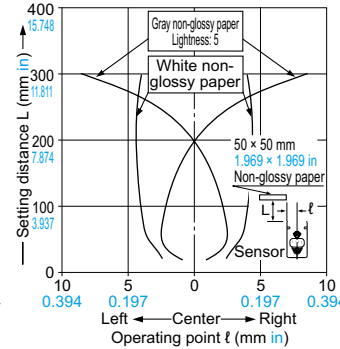
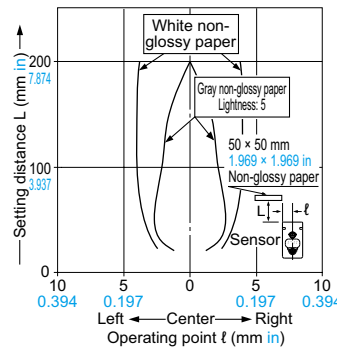
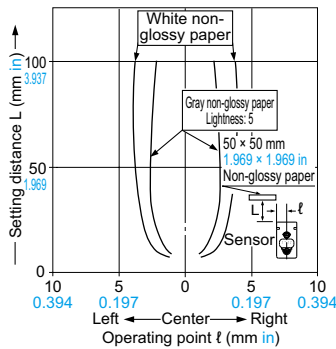
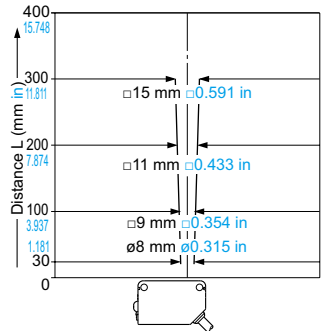

Correlation between color (50 × 50 mm 1.969 × 1.969 in construction paper) and sensing range

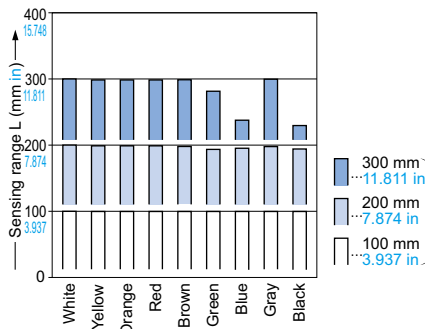

These bars indicate the sensing range with the respective colors when the distance adjuster is set to a sensing range of 300 mm 11.811 in, 200 mm 7.874 in and 100 mm 3.937 in long, respectively, with white color. The sensing range also varies depending on material.

Correlation between material (50 × 50 mm 1.969 × 1.969 in) and sensing range

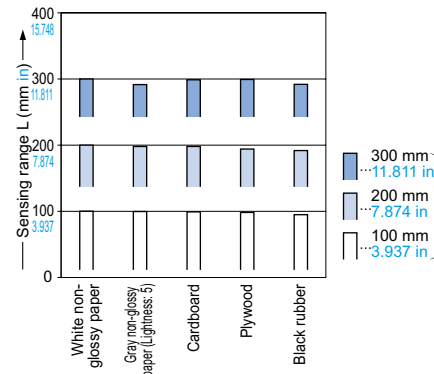

These bars indicate the sensing range with the respective objects when the distance adjuster is set to a sensing range of 300 mm 11.811 in, 200 mm 7.874 in and 100 mm 3.937 in long, respectively, with white non-glossy paper.

All models



- Never use this product as a sensing device for personnel protection.
- In case of using sensing devices for personnel protection, use products which meet laws and standards, such as OSHA, ANSI or IEC etc., for personnel protection applicable in each region or country.

Mounting

- The tightening torque should be 0.5 N·m or less.

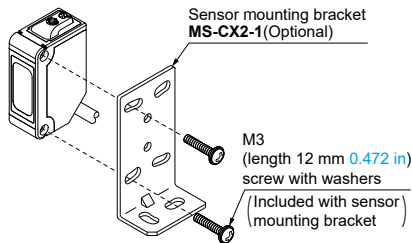

Wiring

- Make sure that the power supply is off while wiring.
- Take care that wrong wiring will damage the sensor.
- Verify that the supply voltage variation is within the rating.
- If power is supplied from a commercial switching regulator, ensure that the frame ground (F.G.) terminal of the power supply is connected to an actual ground.
- In case noise generating equipment (switching regulator, inverter motor, etc.) is used in the vicinity of this product, connect the frame ground (F.G.) terminal of the equipment to an actual ground.
- Do not run the wires together with high-voltage lines or power lines or put them in the same raceway. This can cause malfunction due to induction.
- When connecting an inductive load such as a relay to the output, do not connect a capacitive load to prevent resonance. Also, connect a diode to protect the output circuit.
- Extension up to total 100 m 328.084 ft (thru-beam type: both emitter and receiver) is possible with 0.3 mm², or more, cable. However, in order to reduce noise, make the wiring as short as possible.
- Make sure that stress by forcible bend or pulling is not applied directly to the sensor cable joint.

Others

- This product has been developed / produced for industrial use only.
- Do not use during the initial transient time (50 ms) after the power supply is switched on.
- Take care that the sensor is not directly exposed to fluorescent light from a rapid-starter lamp or a high frequency lighting device, as it may affect the sensing performance.
- This sensor is suitable for indoor use only.
- Do not use this sensor in places having excessive vapor, dust, etc., or where it may come in direct contact with water or corrosive gas.
- Take care that the sensor does not come in direct contact with water, oil, grease or organic solvents, such as, thinner, etc.
- This sensor cannot be used in an environment containing inflammable or explosive gases.
- Never disassemble or modify the sensor.

CX-41 □ CX-42 □ CX-49 □ CX-48 □

Part description and functions

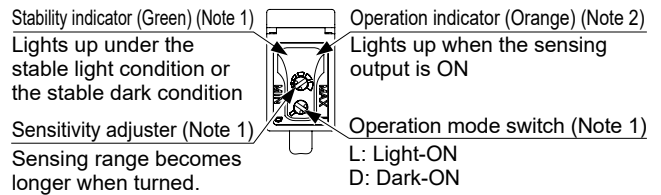

- Notes: 1) Not incorporated on the thru-beam type sensor emitter.
2) It is the power indicator (green, lights up when the power is ON.) for the thru-beam type sensor emitter.

Operation mode switch

Operation mode switch	Description
	Light-ON mode is obtained when the operation mode switch (thru-beam type incorporate it in the receiver) is turned fully clockwise (L side).
	Dark-ON mode is obtained when the operation mode switch (thru-beam type incorporate it in the receiver) is turned fully counter-clockwise (D side).

Note: Use the flathead screwdriver (purchase separately) to turn the operation mode switch slowly.

Beam alignment

Thru-beam type

1. Set the operation mode switch to the Light-ON mode position (L side).
2. Place the emitter and the receiver face to face along a straight line, move the emitter in the up, down, left and right directions, in order to determine the range of the light received condition with the help of the operation indicator (orange). Then, set the emitter at the center of this range.
3. Similarly, adjust for up, down, left and right angular movement of the emitter.
4. Further, perform the angular adjustment for the receiver also.
5. Check that the stability indicator (green) lights up.
6. Choose the operation mode, Light-ON or Dark-ON, as per your requirement, with the operation mode switch.

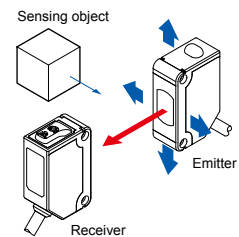

Retroreflective type

1. Set the operation mode switch to the Light-ON mode position (L side).
2. Placing the sensor and the reflector face to face along a straight line, move the reflector in the up, down, left and right directions, in order to determine the range of the light received condition with the help of the operation indicator (orange). Then, set the reflector at the center of this range.
3. Similarly, adjust for up, down, left and right angular movement of the reflector.
4. Further, perform the angular adjustment for the sensor also.
5. Check that the stability indicator (green) lights up.
6. Choose the operation mode, Light-ON or Dark-ON, as per your requirement, with the operation mode switch.

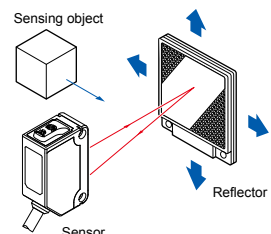

CX-41□ CX-42□ CX-49□ CX-48□

Sensitivity adjustment

Step	Sensitivity adjuster	Description
①		Turn the sensitivity adjuster fully counterclockwise to the minimum sensitivity position, MIN.
②		In the light received condition, turn the sensitivity adjuster slowly clockwise and confirm the point (A) where the sensor enters the "Light" state operation.
③		In the dark condition, turn the sensitivity adjuster further clockwise until the sensor enters the "Light" state operation and then bring it back to confirm point (B) where the sensor just returns to the "Dark" state operation. (If the sensor does not enter the "Light" state operation even when the sensitivity adjuster is turned fully clockwise, the position is point (B).)
④		The position at the middle of points (A) and (B) is the optimum sensing position.

Note: Use the flathead screwdriver (purchase separately) to turn the adjuster slowly. Turning with excessive strength will cause damage to the adjuster.

	Light condition	Dark condition
Thru-beam type		
Retroreflective type		
Diffuse reflective type		

Relation between output and indicators

In case of Light-ON			Sensing condition	In case of Dark-ON		
Stability indicator	Operation indicator	Output		Output	Operation indicator	Stability indicator
●	●	ON	Stable light receiving	OFF	●	●
●	●	ON	Unstable light receiving	OFF	●	●
●	●	OFF	Unstable dark receiving	ON	●	●
●	●	OFF	Stable dark receiving	ON	●	●

●, ●: Lights up, ●: Turns OFF

Retroreflective type sensor (excluding CX-491□)

- Please take care of the following points when detecting materials having a gloss.

- ① Make L, shown in the diagram, sufficiently long.
- ② Install at an angle of 10 to 30 degrees to the sensing object.

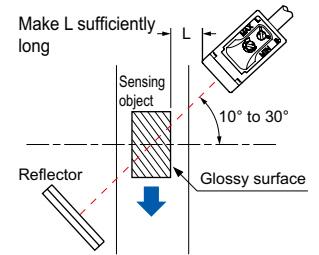

Retroreflective type sensor with polarizing filters (CX-491□)

- If a shiny object is covered or wrapped with a transparent film, such as those described below, the retroreflective type sensor with polarizing filters may not be able to detect it. In that case, follow the steps given below.

Example of sensing objects

- Can wrapped by clear film
- Aluminum sheet covered by plastic film
- Gold or silver color (specular) label or wrapping paper

Steps

- Tilt the sensor with respect to the sensing object while fitting.
- Reduce the sensitivity.
- Increase the distance between the sensor and the sensing object.

CX-48□

Retroreflective type sensor for transparent object sensing (CX-48□)

- Optimum sensing is possible when the position of the transparent sensing object is set at the center of the sensor and the reflector. If the sensing position is set near the sensor or the reflector, the sensing may be unstable. In this case, set the sensing position at the center of the sensor and the reflector.

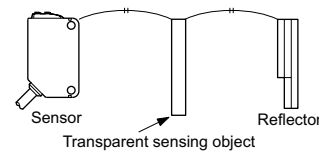

- When the sensor detects an uneven plastic receptacle or glass bottle, the received-light amount may differ with the sensing position or direction. Adjust the sensitivity after confirming the stable sensing condition by turning the sensing object, etc.

- When sensing pipe-shaped transparent sensing object, set it in a standing, not lying, position as shown in Figure A. The sensor may fail to detect a lying object as shown in Figure B.

Correct

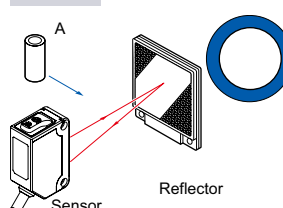

Incorrect

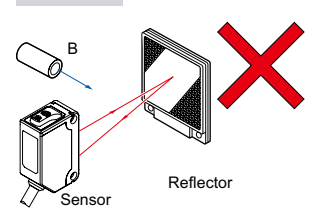

CX-41□

Slit mask (Optional)

- With the slit mask **OS-CX-□**, the sensor can detect a small object. However, the sensing range is reduced when the slit mask is mounted.

How to mount

1. Insert the fixing hook into the fixing groove.
2. Then, pressing the slit mask against the main unit, insert the fixing tab into the fixing groove.

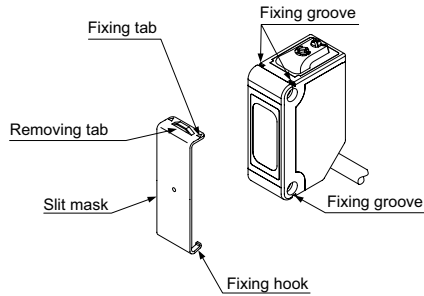

How to remove

1. Insert a screwdriver into the removing tab.
2. Pull forward while lifting the removing tab.

Interference prevention filter (Optional) (only for CX-411□)

- By mounting the interference prevention filters (**PF-CX4-H**, **PF-CX4-V**), two sets of the **CX-411□** can be mounted close together.
- The filters can be mounted and removed in the same way as for the above slit.

(Precaution for use)

- **PF-CX4-H** and **PF-CX4-V** are polarizing filters that allow only vertical light waves and horizontal light waves to pass through, respectively. Take note of the following when using.
 - The detection distance becomes shorter when the sensor units are mounted with the interference prevention filters.
 - There are two types of interference prevention filter. The emitter and receiver of each unit must be installed with different filter types.
 - The interference prevention function does not work if only the emitters or only the receivers are mounted with the filters or if both sensor units are mounted with the same type of filters.

Fitted with **PF-CX4-H**
Direction of thru-beam axis:
horizontal, color of metal: light brown

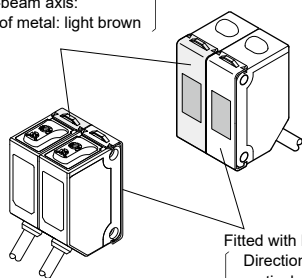

Fitted with **PF-CX4-V**
Direction of thru-beam axis:
vertical, color of metal: silver

* Interference prevention filters have no model indications. Check the filters carefully when mounting on sensors.

- If two sensor units mounted with the interference prevention filters are installed in tilted positions, the detection distance and interference area may become affected. Be sure to mount both units horizontally.

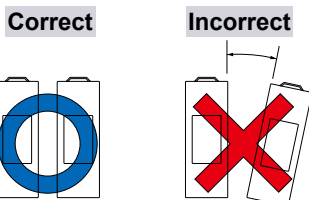

CX-44□

Mounting

- Care must be taken regarding the sensor mounting direction with respect to the object's direction of movement.

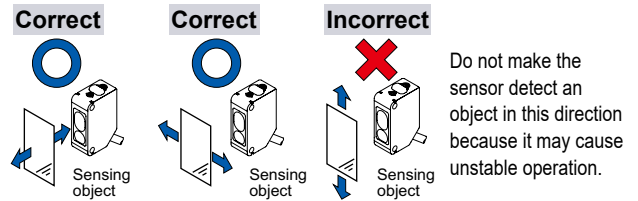

- When detecting a specular object (aluminum or copper foil, etc.) or an object having a glossy surface or coating, please take care that there are cases when the object may not be detected due to a change in angle, wrinkles on the object surface, etc.
- When a specular body is present below the sensor, use the sensor by tilting it slightly upwards to avoid wrong operation.

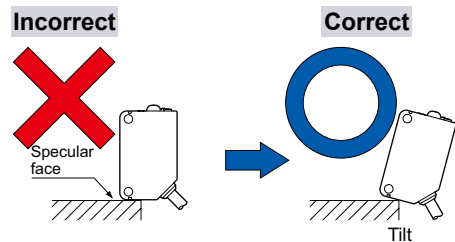

- If a specular body is present in the background, wrong operation may be caused due to a small change in the angle of the background body. In that case, install the sensor at an inclination and confirm the operation with the actual sensing object.
- Take care that there is a non-detectable area right in front of the sensor.

Operation mode switch

Operation mode switch	Description
	Detecting-ON mode is obtained when the operation mode switch is turned fully clockwise (L side).
	Not detecting-ON is obtained when the operation mode switch is turned fully counterclockwise (D side)

Note: Use the flathead screwdriver (purchase separately) to turn the operation mode switch slowly. Turning with excessive strength will cause damage to the adjuster.

- Depending on whether you select the BGS or FGS function, the output operation changes as follows.

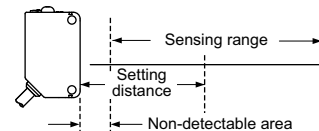

BGS	L-ON		ON OFF
	D-ON		ON OFF
FGS	L-ON		ON OFF
	D-ON		ON OFF

CX-44□

Stability indicator

- Since the CX-44□ use a 2-segment photodiode as its receiving element, and sensing is done based on the difference in the incident beam angle of the reflected beam from the sensing object, the output and the operation indicator (orange) operate according to the object distance.
- Further, the stability indicator (green) shows the margin to the setting distance.

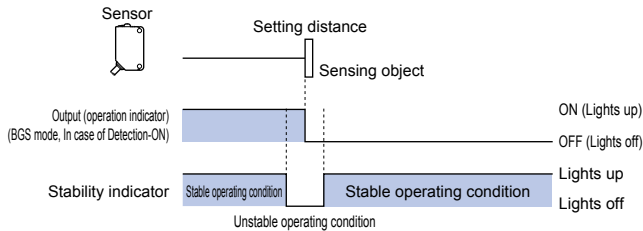

BGS/FGS functions

- This sensor incorporates BGS/FGS functions. Select either BGS or FGS function depending on the positions of the background and sensing object.

BGS function

- This function is used when the sensing object is apart from the background.

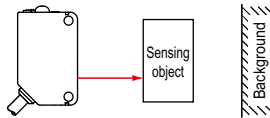

FGS function

- This function is used when the sensing object contacts the background or the sensing object is glossy, etc.
- Please use the FGS function together with a conveyor or other background unit.

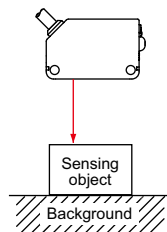

Distance adjustment

- When this product is used, be sure to carry out the distance adjustment.
- Since the distance adjuster of this sensor is a multirotation adjuster, when the point (A) and (B) is adjusted as explained in the table right, there may be more than 1 turn between the point (A) and (B). Therefore, make sure to remember the turns of both points to find the optimum position.
- Be sure to wire the sensing mode selection input (Pink / 2) before distance adjustment. If the wiring is done after the distance adjustment, the sensing area is changed.

- Turn the distance adjuster gradually and lightly with a flathead screwdriver (purchase separately). In order to protect itself, the distance adjuster idles if turned fully. If the adjuster is idled when distance adjustment is done, carry out the adjustment again.

When using the BGS function

<When a sensing object is moving right or left to the sensor>

Step	Description	Distance adjuster
①	Turn the distance adjuster fully counterclockwise to the minimum sensing range position. (CX-441□/444□: 20 mm 0.787 in approx., CX-442□: 40 mm 1.575 in approx.)	Turn fully
②	Place an object at the required distance from the sensor, turn the distance adjuster gradually clockwise, and find out point (A) where the sensor changes to the detecting condition.	
③	Remove the object, turn the adjuster clockwise further until the sensor goes into the detecting state again. Once it has entered, turn the distance adjuster backward until the sensor returns to the non-detecting condition. This position is designated as point (B). When the sensor does not go into the detecting condition even if the adjuster is turned fully clockwise, the position where the adjuster was fully turned is regarded as the point (B). (There may be more than 1 turn between point (A) and (B), since this sensor incorporates a multirotation adjuster.)	
④	The optimum position to stably detect objects is the center point between (A) and (B).	

<When a sensing object is approaching / moving away from the sensor>

- Follow only steps ① and ②. Since the sensing point may change depending on the sensing object, be sure to check the operation with the actual sensing object.

When using the FGS function

- Please use the FGS function together with a conveyor or other background unit.

Step	Description	Distance adjuster
①	Turn the distance adjuster fully clockwise to the maximum sensing range position. (CX-441□: 50 mm 1.969 in approx., CX-444□: 100 mm 3.937 in approx., CX-442□: 300 mm 11.811 in approx.)	Turn fully
②	In the state where the sensor detects the background, turn the distance adjuster gradually counterclockwise, and find out point (A) where the sensor changes to the non-detecting condition.	
③	Place an object at the required distance from the sensor, turn the adjuster counterclockwise further until the sensor goes into the non-detecting condition again. Once entered, turn the distance adjuster backward until the sensor returns to the detecting condition. This position is designated as point (B). When the sensor does not go into the non-detecting condition even if the adjuster is turned fully counterclockwise, the position where the adjuster was fully turned is regarded as the point (B). (There may be more than 1 turn between point (A) and (B), since this sensor incorporates a multirotation adjuster.)	
④	The optimum position to stably detect objects is the center point between (A) and (B).	

Others

- Its distance adjuster is mechanically operated. Do not drop; avoid other shocks.

CX-41□ Sensor

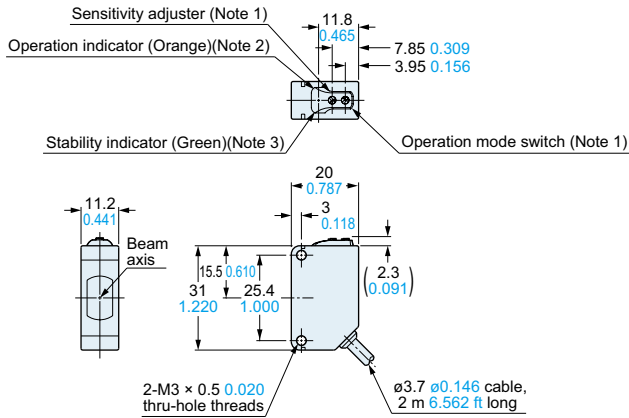

- Notes: 1) Not incorporated on the emitter.
- 2) It is the power indicator (green) on the emitter.
- 3) Not incorporated on the emitter.

CX-41□-Z Sensor

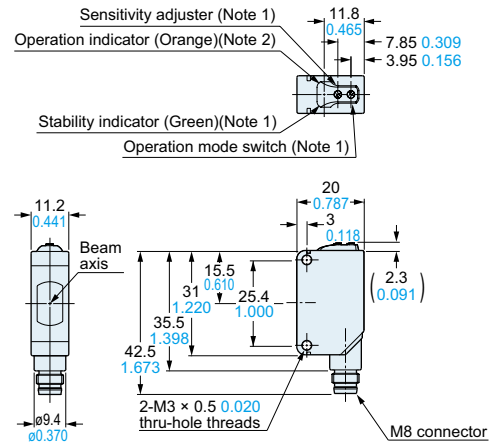

- Notes: 1) Not incorporated on the emitter.
- 2) It is the power indicator (green) on the emitter.

CX-41□-J Sensor

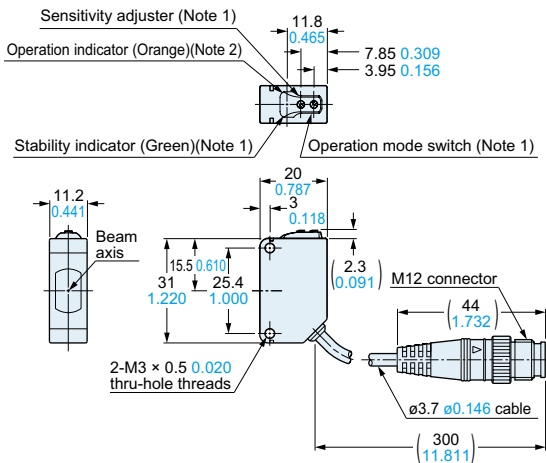

- Notes: 1) Not incorporated on the emitter.
- 2) It is the power indicator (green) on the emitter.

CX-49□ CX-48□ CX-42□ Sensor

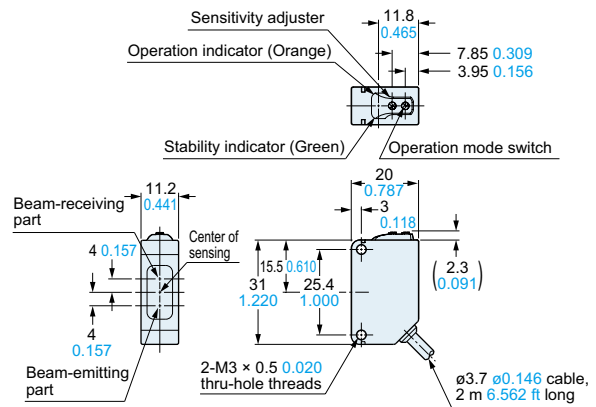

CX-49□-Z CX-48□-Z CX-42□-Z Sensor

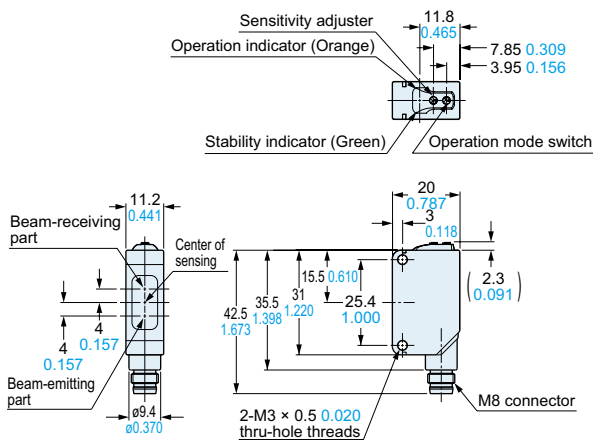

CX-49□-J CX-48□-J CX-42□-J Sensor

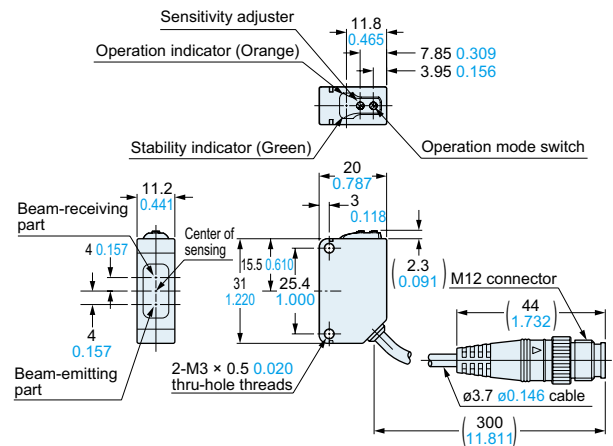

CX-44□

Sensor

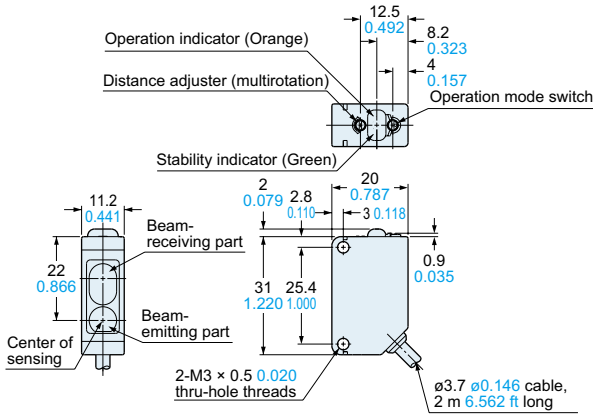

CX-44□-Z

Sensor

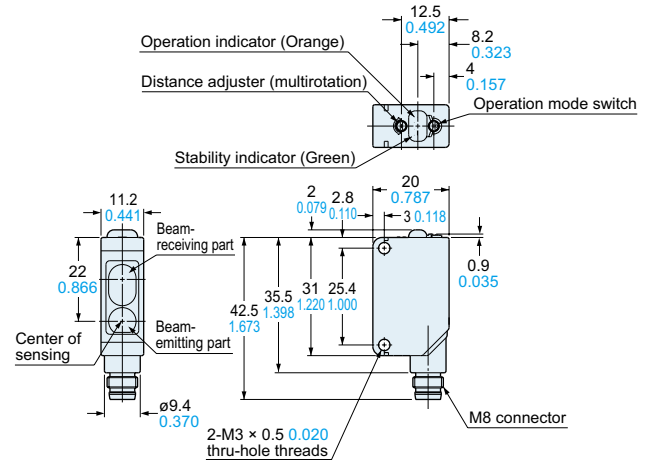

RF-230

Reflector*

* Included in retroreflective type sensors except for sensors without reflector

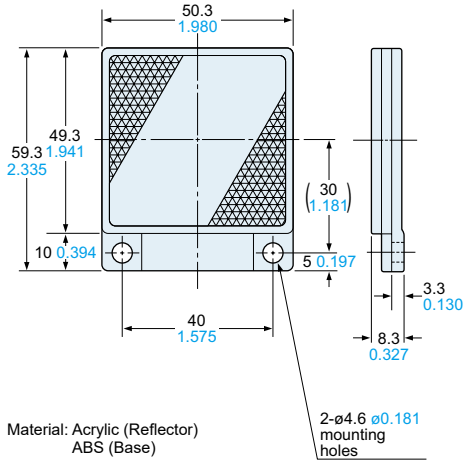

Material: Acrylic (Reflector)
ABS (Base)

RF-220

Reflector (Optional)

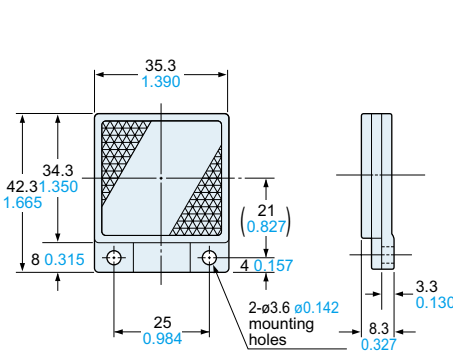

Material: Acrylic (Reflector)
ABS (Base)

RF-210

Reflector (Optional)

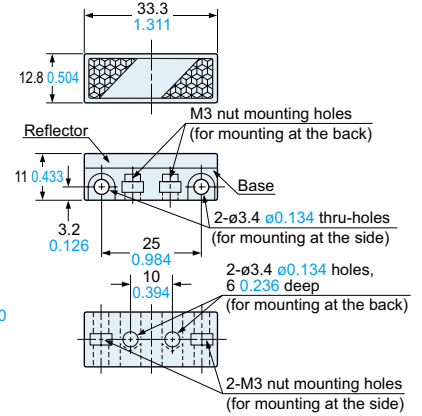

Material: Acrylic (Reflector)
ABS (Base)
Two M3 (length 8 mm 0.315 in) screws with washers and two nuts are attached.

RF-11

Reflective tape (Optional)

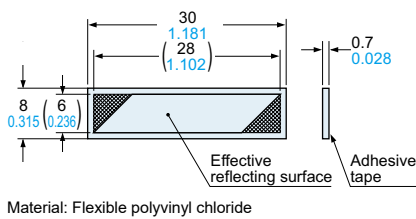

Material: Flexible polyvinyl chloride

RF-12

Reflective tape (Optional)

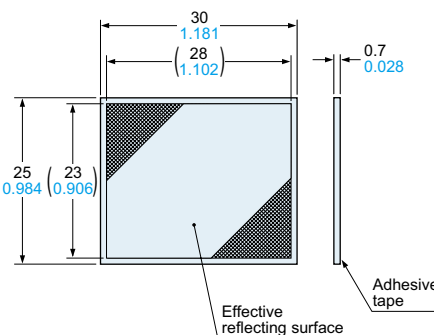

Material: Flexible polyvinyl chloride

RF-13

Reflective tape (Optional)

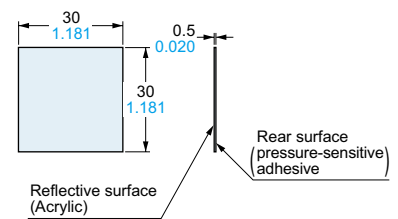

Reflective surface (Acrylic)

MS-CX2-1

Sensor mounting bracket (Optional)

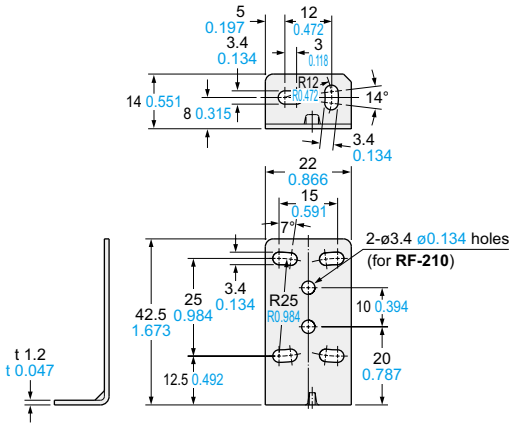

Material: Stainless steel (SUS304)

Two M3 (length 12 mm 0.472 in) screws with washers are attached.

Assembly dimensions

Mounting drawing with the receiver of CX-41□

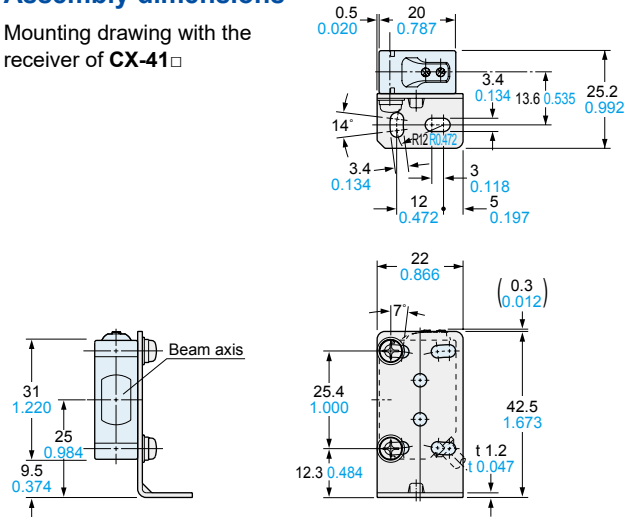

MS-CX2-2

Sensor mounting bracket (Optional)

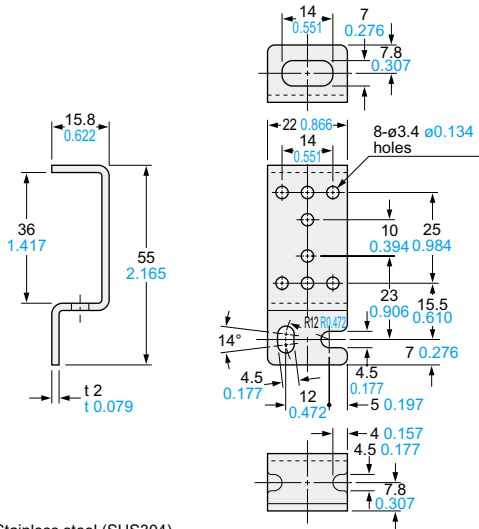

Material: Stainless steel (SUS304)

Two M3 (length 12 mm 0.472 in) screws with washers are attached.

Assembly dimensions

Mounting drawing with the receiver of CX-41□

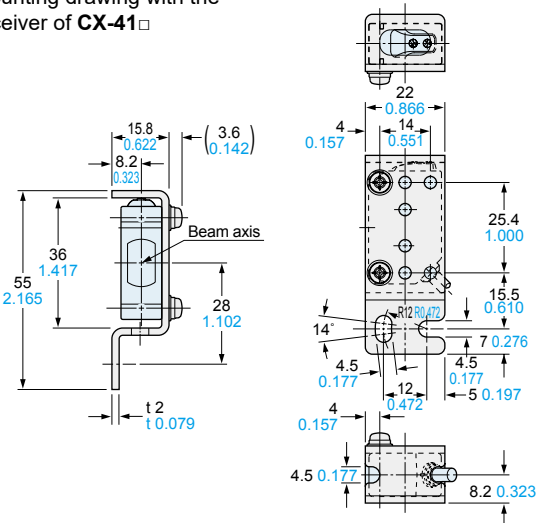

MS-CX2-4

Sensor mounting bracket (Optional)

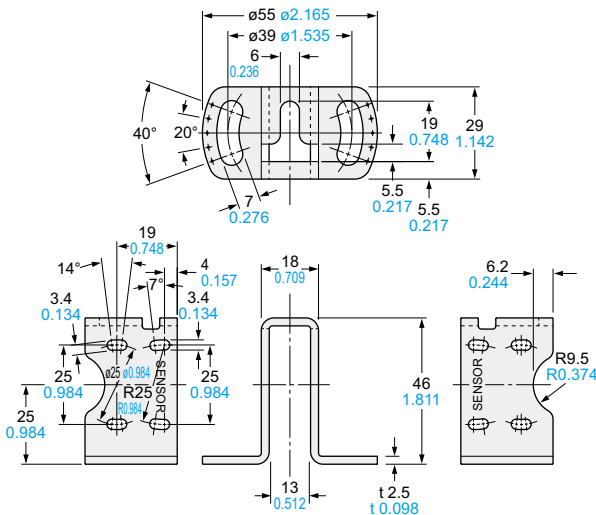

Material: Stainless steel (SUS304)

Two M3 (length 14 mm 0.551 in) screws with washers are attached.

Assembly dimensions

Mounting drawing with the receiver of CX-41□

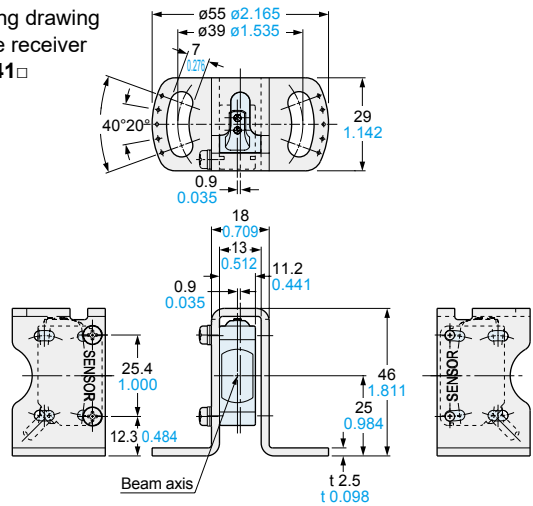

MS-CX2-5

Sensor mounting bracket (Optional)

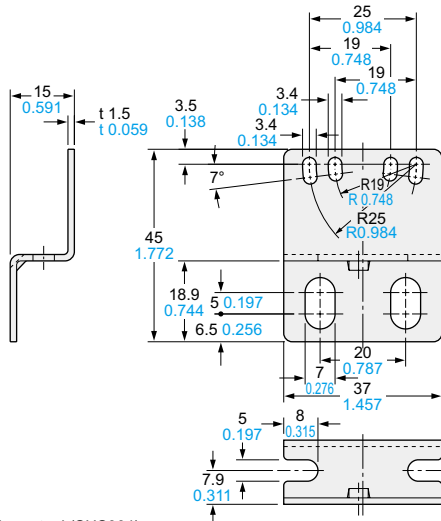

Material: Stainless steel (SUS304)

Two M3 (length 12 mm 0.472 in) screws with washers are attached.

Assembly dimensions

Mounting drawing with the receiver of CX-41 □

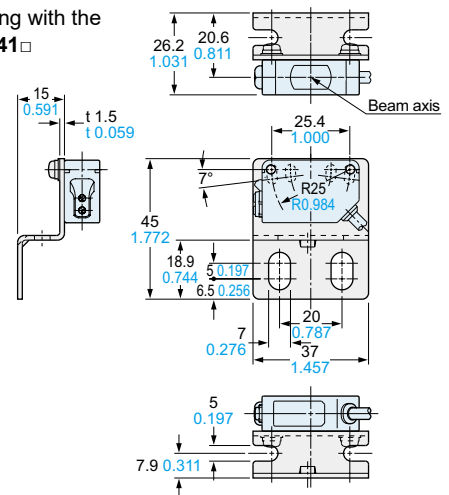

MS-CX-3

Sensor mounting bracket (Optional)

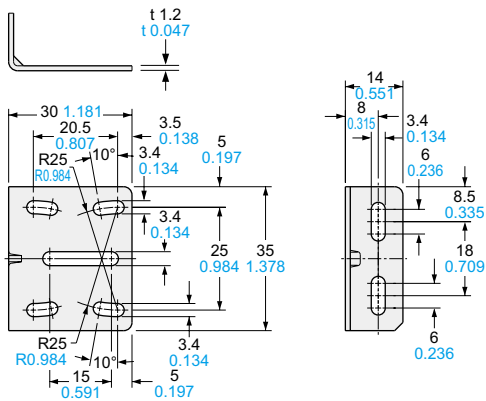

Material: Stainless steel (SUS304)

Two M3 (length 12 mm 0.472 in) screws with washers are attached.

Assembly dimensions

Mounting drawing with the receiver of CX-41 □

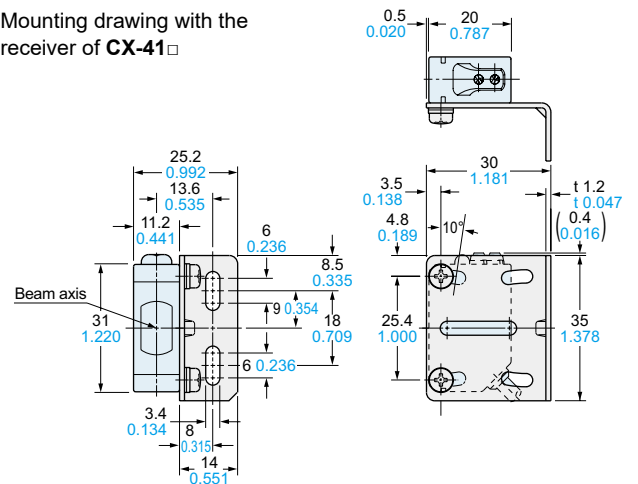

MS-AJ1 Basic assembly

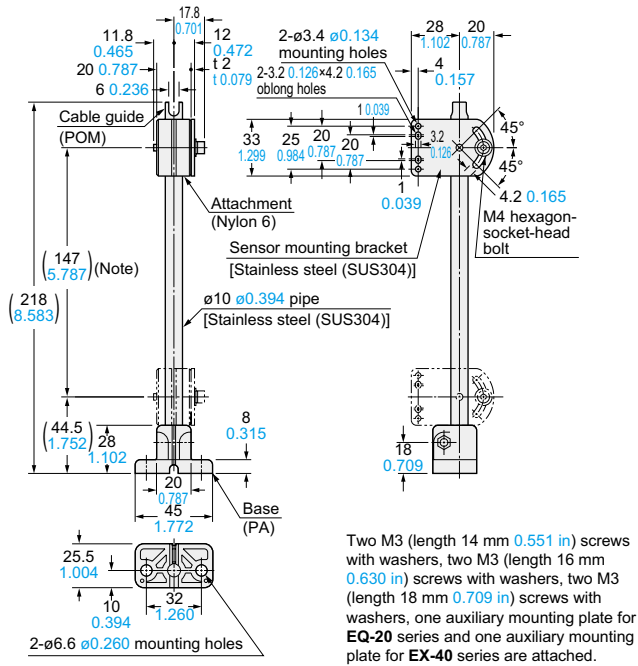

Two M3 (length 14 mm 0.551 in) screws with washers, two M3 (length 16 mm 0.630 in) screws with washers, two M3 (length 18 mm 0.709 in) screws with washers, one auxiliary mounting plate for EQ-20 series and one auxiliary mounting plate for EX-40 series are attached.

Note: The dimensions in the brackets indicate the adjustable range of the movable part.

MS-AJ2 Basic assembly

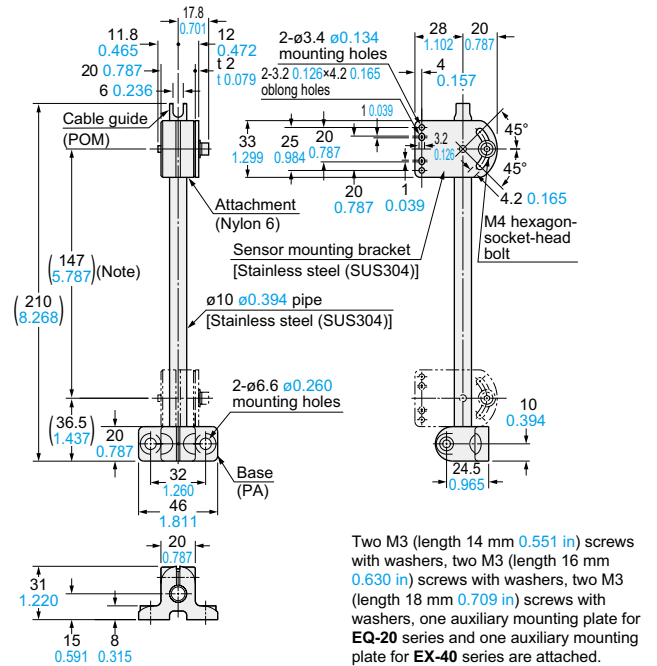

Two M3 (length 14 mm 0.551 in) screws with washers, two M3 (length 16 mm 0.630 in) screws with washers, two M3 (length 18 mm 0.709 in) screws with washers, one auxiliary mounting plate for EQ-20 series and one auxiliary mounting plate for EX-40 series are attached.

Note: The dimensions in the brackets indicate the adjustable range of the movable part.

MS-AJ1 MS-AJ2 Basic assembly

Assembly dimensions with CX-400 series (Mounting part only)

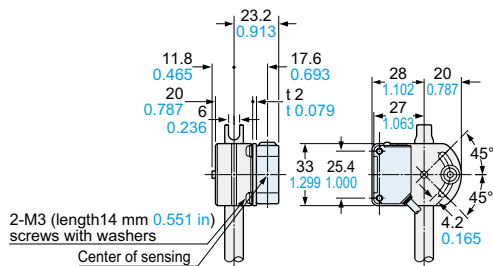

Assembly dimensions with RF-210 (Reflector) (Mounting part only)

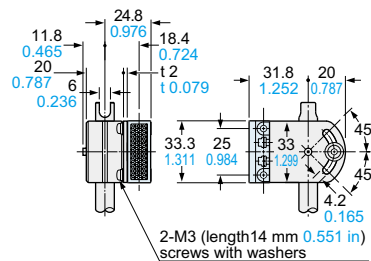

MS-AJ1-M

Assembly for reflector

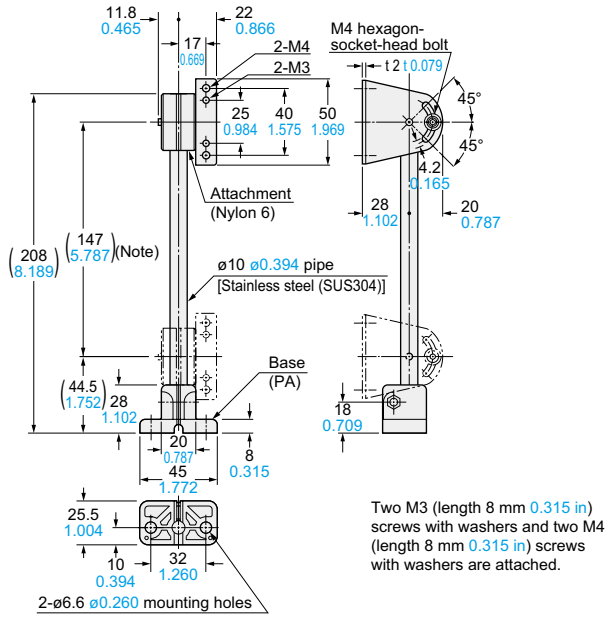

Note: The dimensions in the brackets indicate the adjustable range of the movable part.

MS-AJ2-M

Assembly for reflector

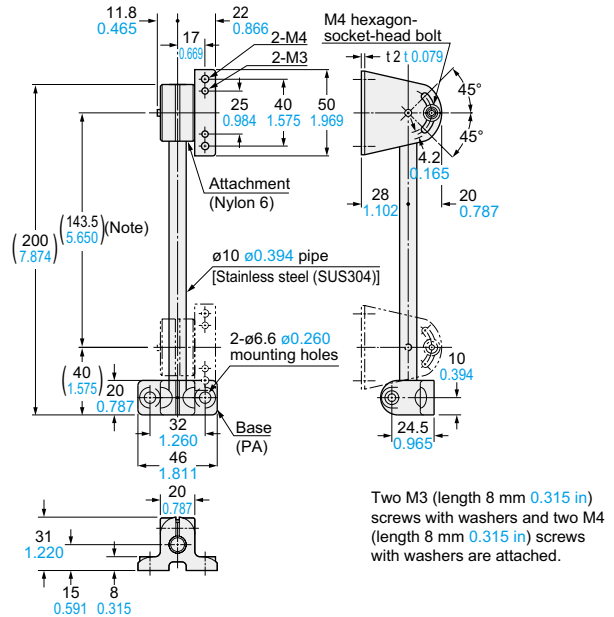

Note: The dimensions in the brackets indicate the adjustable range of the movable part.

MS-AJ1-M MS-AJ2-M

Assembly for reflector

Assembly dimensions with RF-220 (Reflector) (Mounting part only)

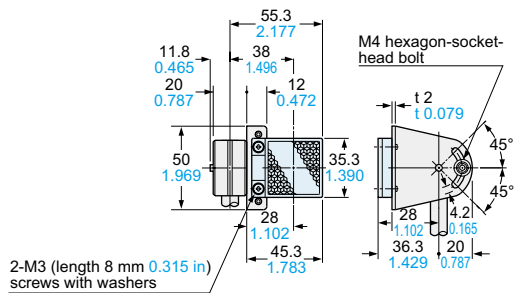

Assembly dimensions with RF-230 (Reflector) (Mounting part only)

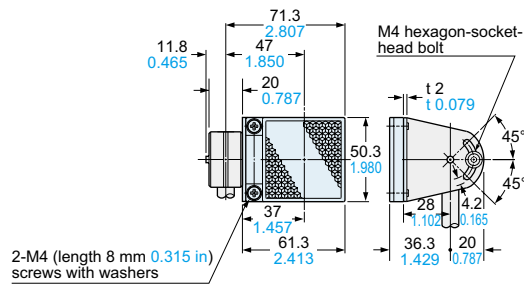

MS-AJ1-A

Lateral arm assembly

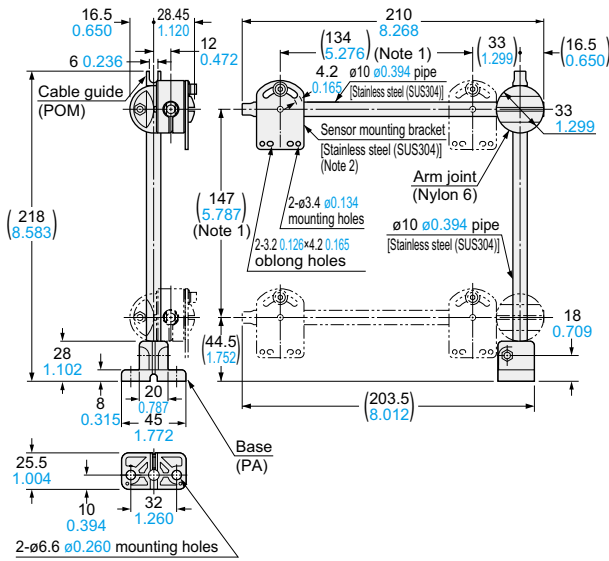

Two M3 (length 14 mm 0.551 in) screws with washers, two M3 (length 16 mm 0.630 in) screws with washers, two M3 (length 18 mm 0.709 in) screws with washers, one auxiliary mounting plate for EQ-20 series and one auxiliary mounting plate for EX-40 series are attached.

- Notes: 1) The dimensions in the brackets indicate the adjustable range of the movable part.
 2) Refer to **MS-AJ1 / MS-AJ2** for the assembly dimensions with the sensor mounting bracket, sensor or reflector.

MS-AJ2-A

Lateral arm assembly

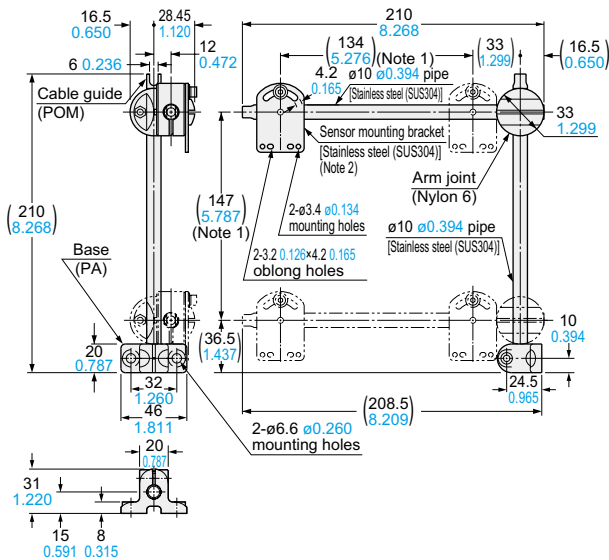

Two M3 (length 14 mm 0.551 in) screws with washers, two M3 (length 16 mm 0.630 in) screws with washers, two M3 (length 18 mm 0.709 in) screws with washers, one auxiliary mounting plate for EQ-20 series and one auxiliary mounting plate for EX-40 series are attached.

- Notes: 1) The dimensions in the brackets indicate the adjustable range of the movable part.
 2) Refer to **MS-AJ1 / MS-AJ2** for the assembly dimensions with the sensor mounting bracket, sensor or reflector.

Disclaimer

The applications described in the catalog are all intended for examples only. The purchase of our products described in the catalog shall not be regarded as granting of a license to use our products in the described applications. We do NOT warrant that we have obtained some intellectual properties, such as patent rights, with respect to such applications, or that the described applications may not infringe any intellectual property rights, such as patent rights, of a third party.

Panasonic
INDUSTRY

Panasonic Industry Co., Ltd.

Industrial Device Business Division
7-1-1, Morofuku, Daito-shi, Osaka 574-0044, Japan
industry.panasonic.com