



# Power Management

Selection Guide 2011

# We create Power Management - We live Energy Efficiency

Being the leader in Energy Efficiency technologies, Infineon's products are enormously important for future energy supplies in terms of both exploiting renewable and using energy efficiently.

Infineon's products stand out for their reliability, their quality excellence and their innovative and leading-edge technology.

Explore our wide offer of high-end products for your applications.

Our innovative Energy Efficiency technologies are a vital contribution to a sustainable and green life on this planet. We are ready to partner with you on concepts for a better world and a better future.

Infineon's products stand out for reliability, quality excellence and technology leadership in power supply, power distribution and renewable energy. Our goal is to create competitive advantages for our customers by driving innovative power architectures, leadership in power density and enabling systems with best cost performance ratio for notebook, server, desktop and graphic cards, consumer SMPS, notebook adapter, PC silverbox, server power supply, e-mobility, solar, telecom supply, industrial welding, induction cooking and aircon.

We would like to invite you to explore our broad offer of leading energy efficient products supporting your application needs.

我们创新的能效技术对这个星球的可持续发展和绿色生活是不可或缺的贡献。我们愿与您共同建设更加美好的世界和未来。

英飞凌产品因其稳定性，卓越的品质，创新和领先的技术而在电源供应领域脱颖而出。利用稳定的技术领先优势，我们驱动着能源结构的创新。我们领先的功率密度使得各种系统能够拥有最佳的性价比：笔记本，服务器，台式机，图形处理卡，消费类开关电源，服务器电源，电动车，太阳能，通信电源，工业焊机，电磁炉和空调。我们诚挚邀请您在我们完整的高性能产品目录中寻找最适合您应用的产品。

# Infineon's semiconductor solutions for energy efficient consumption

## Highly efficient solutions for consumer and computing

- Infineon's latest portfolio of consumer and computing products are consequently optimized along the requirements of the next generation of highest efficient solutions



## Best choice for renewable energy applications

- Regardless for which renewable solution you are looking for, Infineon has the optimal power semiconductor devices to reduce system costs and gain highest efficiency and lifetime



## Smart appliances

- High efficiency chips – the perfect ingredients in the kitchen offering consumers outstanding features and energy saving



## Full range of solutions for e-cars and e-bikes

- Infineon offers the complete set of power train and charging solutions for future mobility concepts – perfectly complementing the body, convenience and safety portfolio



# Contents

Applications	8
Notebook	8
Server, Desktop and Graphic Cards	9
Consumer SMPS	10
Notebook Adapter	11
PC Silverbox	12
Server Power Supply	14
Telecom Power Supply	15
E-Mobility	16
Solar	18
Industrial Welding	20
Induction Heating	21
Aircon	22
Segment Low Voltage	24
Segment High Voltage	48
Segment Silicon Carbide	60
Segment IGBT	66
Segment Power ICS	76
Packages	106
Support	168



# Notebook

## Best Solutions for Small and Cool System Power

Benchmark technologies significantly improve switching losses in power stages and drivers and thus improve battery lifetime and system reliability. Highest efficiency at all load conditions enables system designers to overcome thermal challenges to reach a new level of system miniaturization. Our latest portfolio of notebook products are consequently optimized along the requirements of the next generation notebook platforms and are easy to design in.

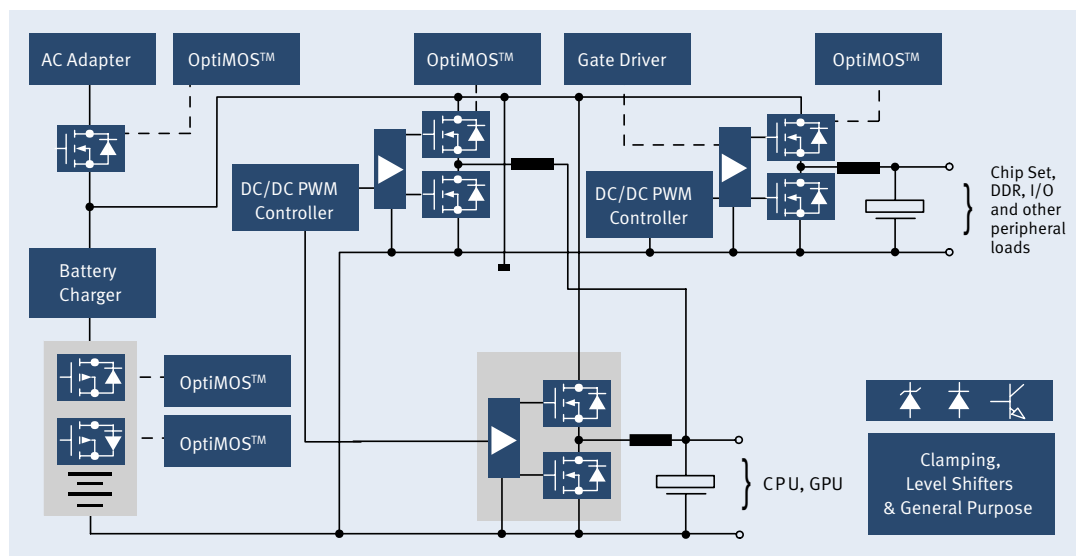

Notebook	Topology	Voltage Class	Technology	Selection
DC / DC	buck converter	30V	New OptiMOS™	recommendation



# Server, Desktop and Graphic Cards

## Highest Power Density for the Next Generation Voltage Regulation Standards

Power management system solutions based on OptiMOS™ technology increase Energy Efficiency in all load conditions, reduce required PCB real estate and are easy to use. Our benchmark solutions demonstrate dramatically increased efficiency even at high currents and high switching frequencies. This supports system designers to achieve their efficiency, power and thermal requirements with a reduced number of phases and thus save overall system cost.

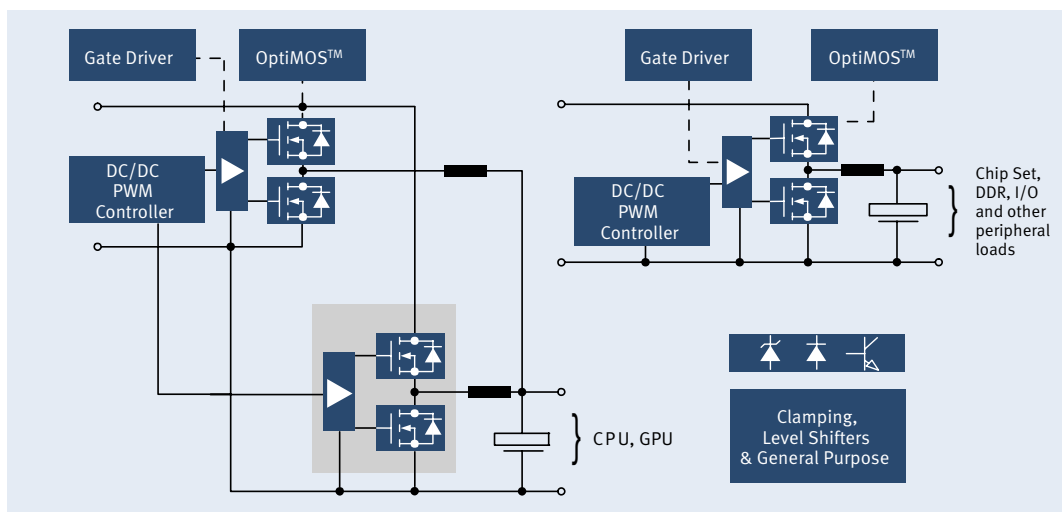

Server, Desktop and Graphic Card	Topology	Voltage Class	Technology	Selection
DC/DC	buck converter	25V	New OptiMOS™	recommendation
	buck converter	30V	New OptiMOS™	reference



# Consumer SMPS

## Cost-effective Products for Consumer SMPS

We offer a wide range of cost-effective products for consumer switch mode power supplies (SMPS). This includes high voltage MOSFETs, control IC's and Silicon Carbide diodes for PFC and PWM stages, as well as low voltage MOSFETs for synchronous rectification. With these products Infineon supports the trends towards continuously reducing power consumption. Especially versatile is the new CoolMOS™ C6/E6 family which combines good efficiency with attractive pricing, as does our 3<sup>rd</sup> generation SiC diodes. For synchronous rectification we recommend our OptiMOS™ series offering extremely low on-state resistance and low capacitances. New control ICs support topologies such as quasi-resonant flyback and LLC.

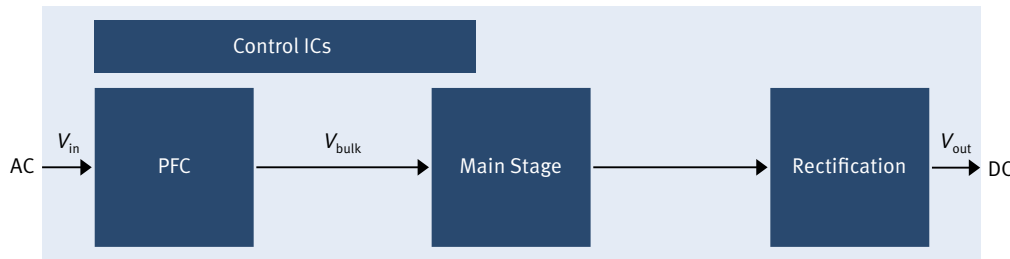

Consumer SMPS	Topology	Voltage Class	Technology	Selection
AC / DC	PFC	600V	CoolMOS™ C6/E6	ease of use
	PFC	600V	CoolMOS™ CP	Efficiency
	PFC	600V	CoolMOS™ C6/E6	Recommendation
DC / DC	2 Switch-Forward DC-DC (TTF)	600V	CoolMOS™ C6/E6	ease of use
	2 Switch-Forward DC-DC (TTF)	600V	CoolMOS™ CP	Efficiency
	2 Switch-Forward DC-DC (TTF)	600V	CoolMOS™ CP	Recommendation
	Flyback DC-DC	650V	CoolMOS™ C6/E6	ease of use
	Flyback DC-DC	650V	CoolMOS™ C6/E6	Efficiency
	Flyback DC-DC	650V	CoolMOS™ C6/E6	Recommendation
	Single stage	650V	CoolMOS™ C6/E6	ease of use
	Single stage	600V	CoolMOS™ CP	Efficiency
	LLC HB DC-DC	650V	CoolMOS™ CFD2	ease of use
	LLC HB DC-DC	600V	CoolMOS™ C6/E6	Efficiency
	LLC HB DC-DC	650V	CoolMOS™ CFD2	Recommendation
	Quasi-Resonat Flyback DC-DC	900V	CoolMOS™ C3	ease of use
	Quasi-Resonat Flyback DC-DC	900V	CoolMOS™ C3	Efficiency
	Quasi-Resonat Flyback DC-DC	900V	CoolMOS™ C3	Recommendation
	Active Clamp Forward	800V	CoolMOS™ C3	ease of use
	Active Clamp Forward	800V	CoolMOS™ C3	Efficiency
	Active Clamp Forward	800V	CoolMOS™ C3	Recommendation
	ZVS Asum. Half-Bridge DC-DC	650V	CoolMOS™ CFD2	ease of use
ZVS Asum. Half-Bridge DC-DC	600V	CoolMOS™ C6/E6	Efficiency	
ZVS Asum. Half-Bridge DC-DC	650V	CoolMOS™ CFD2	Recommendation	
ITTF	600V	CoolMOS™ C6/E6	ease of use	
ITTF	500V	CoolMOS™ CP	Efficiency	
ITTF	600V	CoolMOS™ C6/E6	Recommendation	
Rectification		150-250 V	OptiMOS™	Recommendation
Aux	CoolSET™	650-800V	CoolSET™	Recommendation



# Notebook Adapter

## Leading-edge Technologies for Notebook Adapters

We offer a wide range of products for notebook adapters including high voltage MOSFETs and control ICs for both PFC and PWM stage, as well as low voltage MOSFETs for synchronous rectification. With these products Infineon supports the trends towards a significantly higher efficiency level, especially in partial load condition, as well as towards miniaturization of the adapter. Especially versatile is the CoolMOST™ C6/E6 family which combines good efficiency with ease of use. For synchronous rectification we recommend our OptiMOST™ series, offering extremely low on-state resistance and low capacitances. New control ICs support topologies such as quasi-resonant flyback and LLC, which gain market share within the notebook adapter segment.

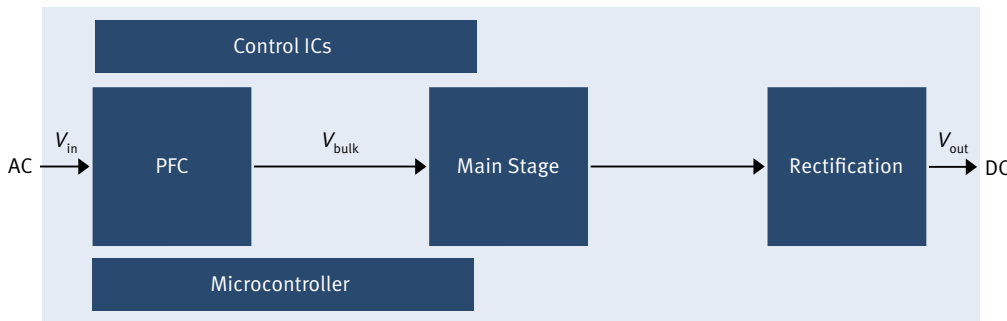

Notebook Adapter	Topology	Voltage Class	Technology	Selection
AC / DC	PFC	600V	CoolMOST™ C6/E6	ease of use
	PFC	600V	CoolMOST™ CP	Efficiency
	PFC	600V	CoolMOST™ C6/E6	Recommendation
DC / DC	Flyback DC-DC	650V	CoolMOST™ C6/E6	ease of use
	Flyback DC-DC	650V	CoolMOST™ C6/E6	Efficiency
	Flyback DC-DC	650V	CoolMOST™ C6/E6	Recommendation
	Single stage	650V	CoolMOST™ C6/E6	ease of use
	Single stage	600V	CoolMOST™ CP	Efficiency
	LLC HB DC-DC	650V	CoolMOST™ CFD2	ease of use
	LLC HB DC-DC	600V	CoolMOST™ C6/E6	Efficiency
	LLC HB DC-DC	650V	CoolMOST™ CFD2	Recommendation
	Quasi-Resonat Flyback DC-DC	900V	CoolMOST™ C3	ease of use
	Quasi-Resonat Flyback DC-DC	900V	CoolMOST™ C3	Efficiency
	Quasi-Resonat Flyback DC-DC	900V	CoolMOST™ C3	Recommendation
	Active Clamp Forward	800V	CoolMOST™ C3	ease of use
	Active Clamp Forward	800V	CoolMOST™ C3	Efficiency
Active Clamp Forward	800V	CoolMOST™ C3	Recommendation	
Rectification	Synchronous Rectification	100-120V	OptiMOST™	Recommendation
Aux	CoolSET™	650-800V	CoolSET™	Recommendation



## PC Silverbox

### Highest Efficiency with new Topologies for PC Silverbox

The PC Silverbox has seen a tremendous race towards higher efficiency with peak values in the range of 92% and above. Special care is dedicated to the 20% load point. We support these trends with our range of high voltage and low voltage MOSFETs as well as control ICs for power factor correction and PWM. Especially versatile is the CoolMOS™ C6/E6 family, our latest technology in the superjunction field, which was pioneered by Infineon Technologies. CoolMOS™ C6/E6 offers easy paralleling and good efficiency even with less ideal PCB layout. The family is specifically recommended for resonant topologies such as LLC due to its high body diode ruggedness, for hard switching topologies such as TTF we recommend the CoolMOS™ C6/E6. New control ICs support continuous current mode PFC and the LLC topology. For the synchronous rectification and the DC/DC we recommend our OptiMOS™ series, which combine extremely low on-state resistance and low capacitances.

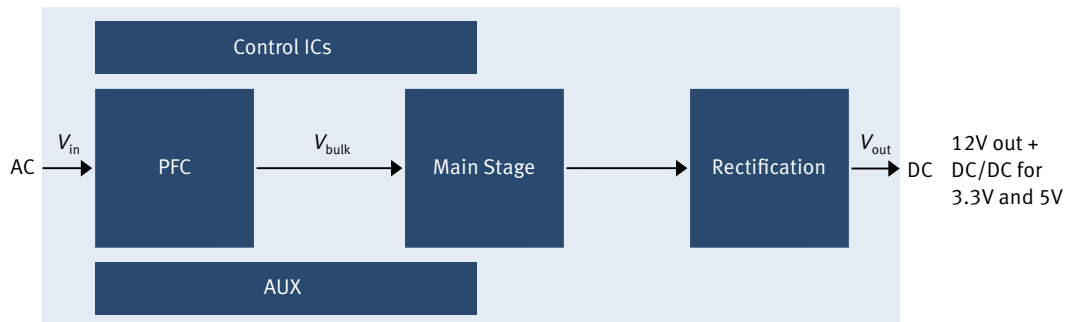

PC Silverbox	Topology	Voltage Class	Technology	Selection
AC / DC	PFC	600V	CoolMOST™ C6/E6	ease of use
	PFC	600V	CoolMOST™ CP	Efficiency
	PFC	600V	CoolMOST™ C6/E6	Recommendation
DC / DC	2 Switch-Forward DC-DC (TTF)	600V	CoolMOST™ C6/E6	ease of use
	2 Switch-Forward DC-DC (TTF)	600V	CoolMOST™ CP	Efficiency
	2 Switch-Forward DC-DC (TTF)	600V	CoolMOST™ CP	Recommendation
	Flyback DC-DC	650V	CoolMOST™ C6/E6	ease of use
	Flyback DC-DC	650V	CoolMOST™ C6/E6	Efficiency
	Flyback DC-DC	650V	CoolMOST™ C6/E6	Recommendation
	Single stage	650V	CoolMOST™ C6/E6	ease of use
	Single stage	600V	CoolMOST™ CP	Efficiency
	LLC HB DC-DC	650V	CoolMOST™ CFD2	ease of use
	LLC HB DC-DC	600V	CoolMOST™ C6/E6	Efficiency
	LLC HB DC-DC	650V	CoolMOST™ CFD2	Recommendation
	Quasi-Resonat Flyback DC-DC	900V	CoolMOST™ C3	ease of use
	Quasi-Resonat Flyback DC-DC	900V	CoolMOST™ C3	Efficiency
	Quasi-Resonat Flyback DC-DC	900V	CoolMOST™ C3	Recommendation
	Active Clamp Forward	800V	CoolMOST™ C3	ease of use
	Active Clamp Forward	800V	CoolMOST™ C3	Efficiency
	Active Clamp Forward	800V	CoolMOST™ C3	Recommendation
	ZVS Asum. Half-Bridge DC-DC	650V	CoolMOST™ CFD2	ease of use
	ZVS Asum. Half-Bridge DC-DC	600V	CoolMOST™ C6/E6	Efficiency
	ZVS Asum. Half-Bridge DC-DC	650V	CoolMOST™ CFD2	Recommendation
	ITTF	600V	CoolMOST™ C6/E6	ease of use
ITTF	500V	CoolMOST™ CP	Efficiency	
ITTF	600V	CoolMOST™ C6/E6	Recommendation	
Rectification	Synchronous Rectification	40-80V	OptiMOST™	Recommendation
Aux	CoolSET™	650-800V	CoolSET™	Recommendation



# Server Power Supply

## Technologies for best Efficiency in Servers

The server market has seen a tremendous shift towards higher efficiency with peak values in the range of 95% and above.

We specifically recommend our CoolMOS™ C6/E6 series for hard switching applications such as continuous current mode PFC and interleaved two transistor forward. For resonant switching applications such as phase shift ZVS or LLC, we offer a wide range of products from the CoolMOS™ C6/E6 series, our latest technology in the superjunction field. For the PFC stage our third generation of SiC Schottky barrier diode offers best cost-performance ratio in the market. For synchronous rectification we offer various voltage classes of the OptiMOS™ such as OptiMOS™ 75V series for 12V output. With ultra-low on-state resistance and very low capacitances the OptiMOS™ series will boost your design to best efficiency. Furthermore, we offer control ICs for the CCM PFC and isolated drivers such as the 1ED and 2ED series.

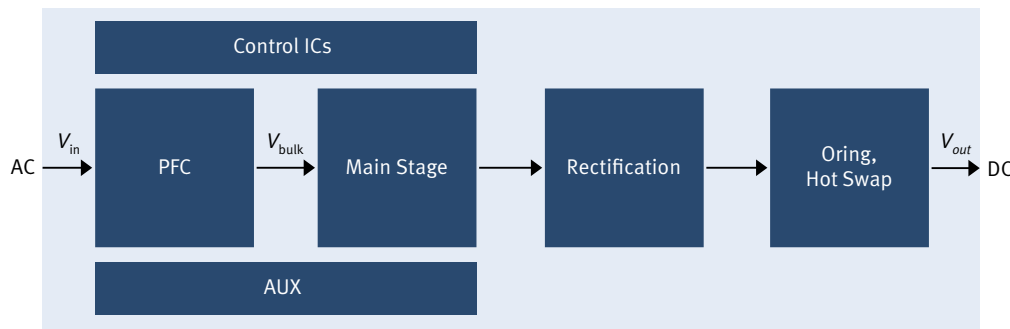

Server Power Supply	Topology	Voltage Class	Technology	Selection
AC / DC	PFC	600V	CoolMOS™ C6/E6	ease of use
	PFC	600V	CoolMOS™ CP	Efficiency
	PFC	600V	CoolMOS™ C6/E6	Recommendation
	Bridgless PFC	600V	CoolMOS™ C6/E6	ease of use
	Bridgless PFC	600V	CoolMOS™ CP	Efficiency
	Bridgless PFC	600V	CoolMOS™ C6/E6	Recommendation
DC / DC	LLC HB DC-DC	650V	CoolMOS™ CFD2	ease of use
	LLC HB DC-DC	600V	CoolMOS™ C6/E6	Efficiency
	LLC HB DC-DC	650V	CoolMOS™ CFD2	Recommendation
	ZVS Asum. Half-Bridge DC-DC	650V	CoolMOS™ CFD2	ease of use
	ZVS Asum. Half-Bridge DC-DC	600V	CoolMOS™ C6/E6	Efficiency
	ZVS Asum. Half-Bridge DC-DC	650V	CoolMOS™ CFD2	Recommendation
	ZVS Full Bridge Phase Shift	650V	CoolMOS™ CFD2	ease of use
	ZVS Full Bridge Phase Shift	600V	CoolMOS™ C6/E6	Efficiency
	ZVS Full Bridge Phase Shift	650V	CoolMOS™ CFD2	Recommendation
	ITTF	600V	CoolMOS™ C6/E6	ease of use
	ITTF	500V	CoolMOS™ CP	Efficiency
ITTF	600V	CoolMOS™ C6/E6	Recommendation	
Rectification	Synchronous Rectification	40-80V	OptiMOS™	Recommendation
Aux	CoolSET™	650-800V	CoolSET™	Recommendation



# Telecom Power Supply

## Energy Efficiency for Telecom Power Supply

The Telecom Supply market has grown fast within the last years. High efficiency targets are required across the entire load range starting at 20% or even at 10% load. We support these trends with our range of high voltage MOSFETs and SiC Schottky barrier diodes as well as our low voltage MOSFET Series for synchronous rectification and Oring.

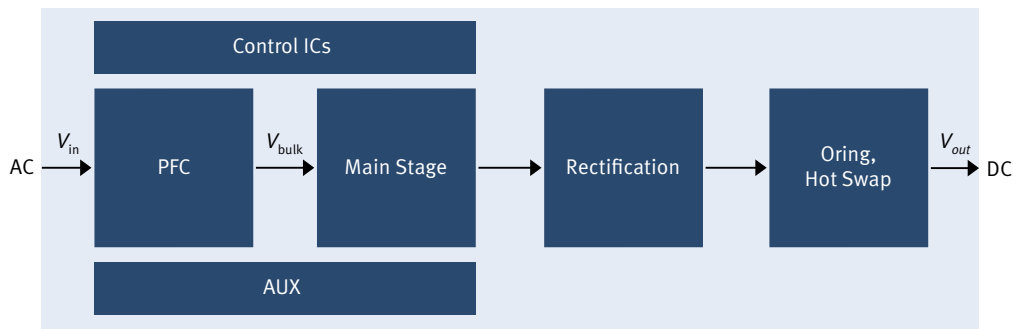

T	Topology	Voltage Class	Technology	Selection
AC / DC	PFC	600V	CoolMOST™ C6/E6	ease of use
	PFC	600V	CoolMOST™ CP	Efficiency
	PFC	600V	CoolMOST™ C6/E6	Recommendation
	Bridgless PFC	600V	CoolMOST™ C6/E6	ease of use
	Bridgless PFC	600V	CoolMOST™ CP	Efficiency
	Bridgless PFC	600V	CoolMOST™ C6/E6	Recommendation
DC / DC	LLC HB DC-DC	650V	CoolMOST™ CFD2	ease of use
	LLC HB DC-DC	600V	CoolMOST™ C6/E6	Efficiency
	LLC HB DC-DC	650V	CoolMOST™ CFD2	Recommendation
	ZVS Asum. Half-Bridge DC-DC	650V	CoolMOST™ CFD2	ease of use
	ZVS Asum. Half-Bridge DC-DC	600V	CoolMOST™ C6/E6	Efficiency
	ZVS Asum. Half-Bridge DC-DC	650V	CoolMOST™ CFD2	Recommendation
	ZVS Full Bridge Phase Shift	650V	CoolMOST™ CFD2	ease of use
	ZVS Full Bridge Phase Shift	600V	CoolMOST™ C6/E6	Efficiency
	ZVS Full Bridge Phase Shift	650V	CoolMOST™ CFD2	Recommendation
	ITTF	600V	CoolMOST™ C6/E6	ease of use
	ITTF	500V	CoolMOST™ CP	Efficiency
	ITTF	600V	CoolMOST™ C6/E6	Recommendation
	ITTF	600V	CoolMOST™ C6/E6	ease of use
	ITTF	500V	CoolMOST™ CP	Efficiency
ITTF	600V	CoolMOST™ C6/E6	Recommendation	
Rectification	Synchronous Rectification	40-200V	OptiMOST™	Recommendation
Aux	CoolSET™	650-800V	CoolSET™	Recommendation



# E-Mobility

## Best Solutions for Battery Charger

To recharge the battery of an electric car, a charger is needed. In cars with on-board chargers the batteries can be recharged by plugging them into a standard power outlet at home. Battery charging via the power grid requires a flexible switching structure in order to handle the different voltage levels and available power existing in different countries. Because charging time is a very important factor for most motorists, on-board chargers have to be very efficient so that they are as small and light as possible. A long-term trend is towards bi-directional charger functions for not only drawing current from the grid but feeding excess energy back into it. Infineon's comprehensive portfolio of semiconductors (sensors, microcontrollers, power semiconductors, power modules, etc.) lends itself perfectly to compact charging units. The products also function at high switching frequencies for use in small and light charger designs. Our products in this sector include MOSFETs: CoolMOST™ and the flexible Easy 1B/2B power modules for overnight low-amp charging, HybridPACK™1 for fast charging with high amps and high-performance 16- and 32-bit microcontroller solutions.

### AC/DC Battery Charger

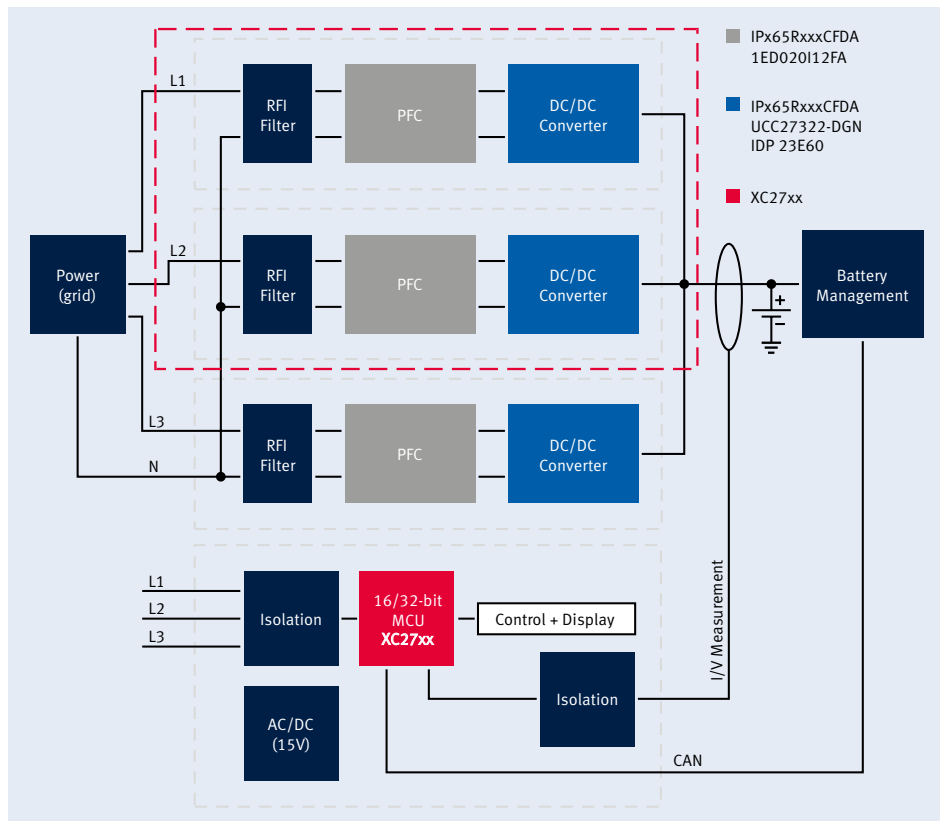

Ecar (Battery charger)	Topology	Voltage	Technology	Selection
AC / DC	Bridgeless converter	650V	CoolMOST™ CFDA	Recommendation
	Totem Pole	650V	CoolMOST™ CFDA	Recommendation
DC / DC	ZVS Phase Shifted Full Bridge	650V	CoolMOST™ CFDA	Recommendation
	LLC Converter	650V	CoolMOST™ CFDA	Recommendation
Control Board	-		Microcontroller XC27xx	Recommendation

## Best Solution for Battery Management

The Battery Management System (BMS) controls battery charge and discharge. An intelligent battery management system is necessary to lengthen battery life, which reduces the vehicle cost over its entire lifetime. The system constantly controls the functionality and state of charge of the battery cells. As they age, the storage capacity of the individual battery cells may lessen at a different speed for each cell. The challenge is to optimize cell utilization. Circuits to test the cells, and active balancing of the cells during the charging and discharging process enable the battery life and cruising range to be effectively lengthened. Our solution for active cell balancing increases usable battery capacity by over 10 percent. The company's microcontrollers and sensors monitor functionality, charge and depth of discharge. These include the 8-bit XC886CM microcontroller family, the 16/32-bit XC22xx microcontroller family, the OptiMOS™ low-voltage MOSFETs, the TLE 6250/51 CAN transceivers as well as the TLE 6389-2GV and TLE 42994GM controllers.

### Battery Management

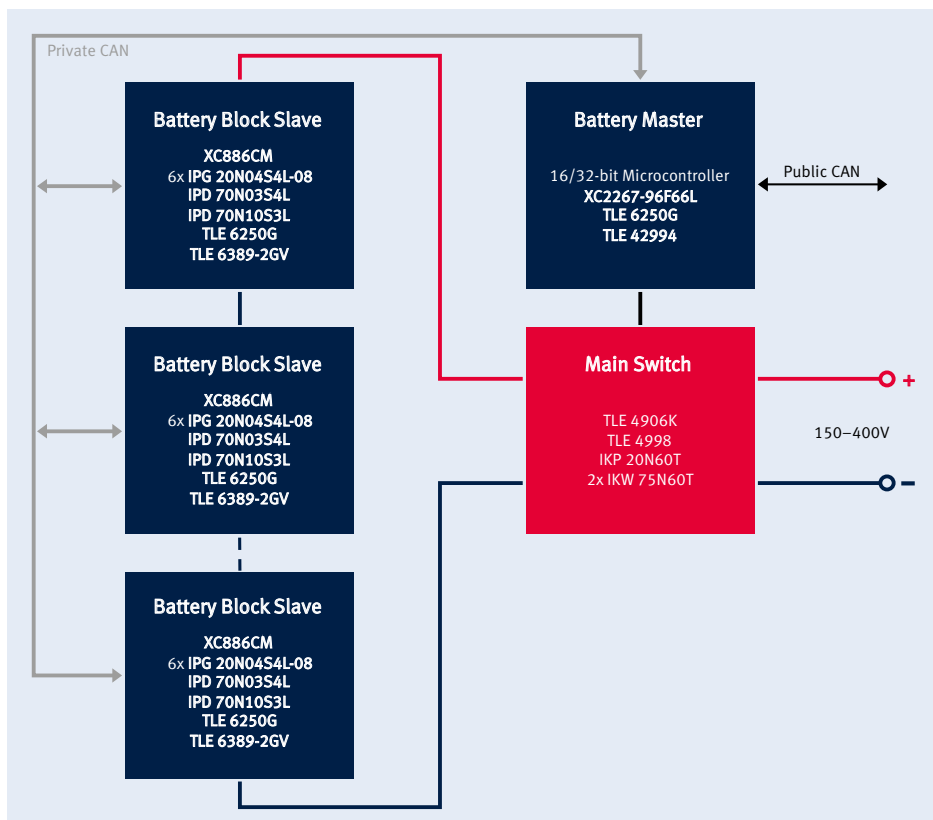

Ecar (Battery management)	Topology	Voltage	Technology	Selection
Main Switch	high power high current	600V	IGBT Trenchstop™	Recommendation
Battery Block Slave	step up step down	30V	OptiMOS™	Recommendation
		40V	OptiMOS™	Recommendation
		100V	OptiMOS™	Recommendation



# Solar

## Performance Products for Highest Inverter Efficiencies

In 2010 Solar Power experienced significant growth worldwide. At the end of 2008 the world's cumulative installed photovoltaic capacity approached 16 GW, in 2009 it reached 23 GW. In 2010, almost 40 GW are installed globally and produce around 50 TWh of electricity every year. While the EU has dominated the world market, the fastest Solar Power growth is expected to continue in China and India, followed by South-East Asia, Latin America and the MENA countries.\*

Improving efficiency is the number one objective in the field of photovoltaics:

Ways of converting solar energy into electricity more efficiently are required in order to optimize the technology's cost-effectiveness. Efficiency gains of as little as one percent can still yield enormous returns in this segment.

Infineon provides a comprehensive portfolio of high-performance products – including CoolMOS™, IGBTs, Silicon Carbide, IGBT modules and driver ICs – to help customers achieve their aims. These high-performance products boost the reliability and efficiency of inverters for photovoltaic applications. As the leader in high-efficiency technologies, we enable customers in realizing photovoltaic inverter efficiencies of up to 99%.

Example:  
Single phase solution, isolated

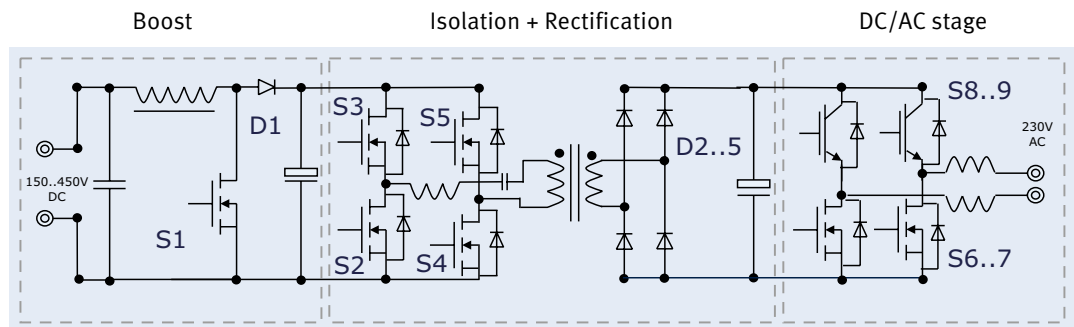

Devices	Function	Recommended IFX parts
S1	Boost switch	CoolMOS™ 650V C6
D1	Boost diode	SiC SBD 600V Gen 3
S2..S5	PWM switches	CoolMOS™ 650V CFD2
D2..D5	Rectification diodes	SiC SBD 600V Gen 3
S6..S7	High frequency output switches	CoolMOS™ 650V CFD2
S8..S9	Polarity selection switches	IGBT 600V T (trench & field stop)

\* Source: EPIA Global Market Outlook for Photovoltaics Until 2015

Example:  
SOLAR Microinverter

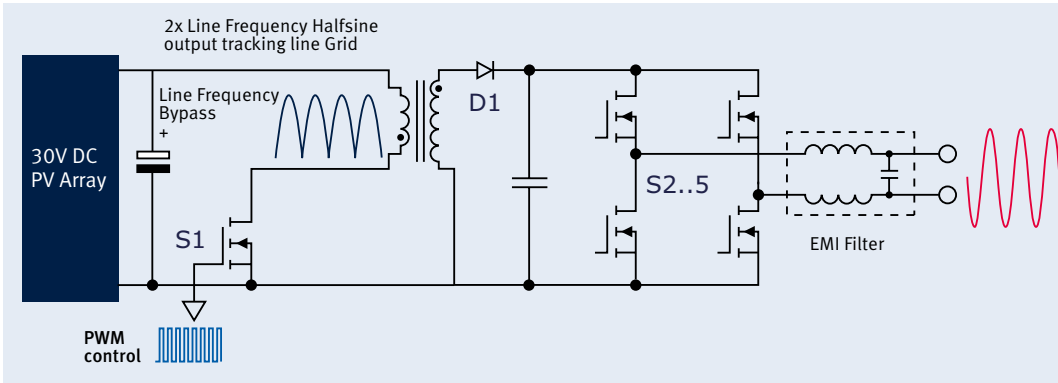

Devices	Function	Recommended IFX parts
S1	Primary side switch	OptiMOS™ 150V
D1	Rectifying diode	SiC Schottky barrier Diode 1200V
S2...S5	Unfolding bridge	CoolMOS™ 800V



# Industrial Welding (MMA < 280A)

## Our IGBTs for Welding - the power is in your hands

In the field of industrial welding, discretés are used for home and small inverterised welders. Infineon's high speed devices are used to reduce the size of the active components and transformer (25kHz --> 70kHz). Infineon's IGBTs offer high speed/high performance to get the best out of your system.

### Welding Inverter

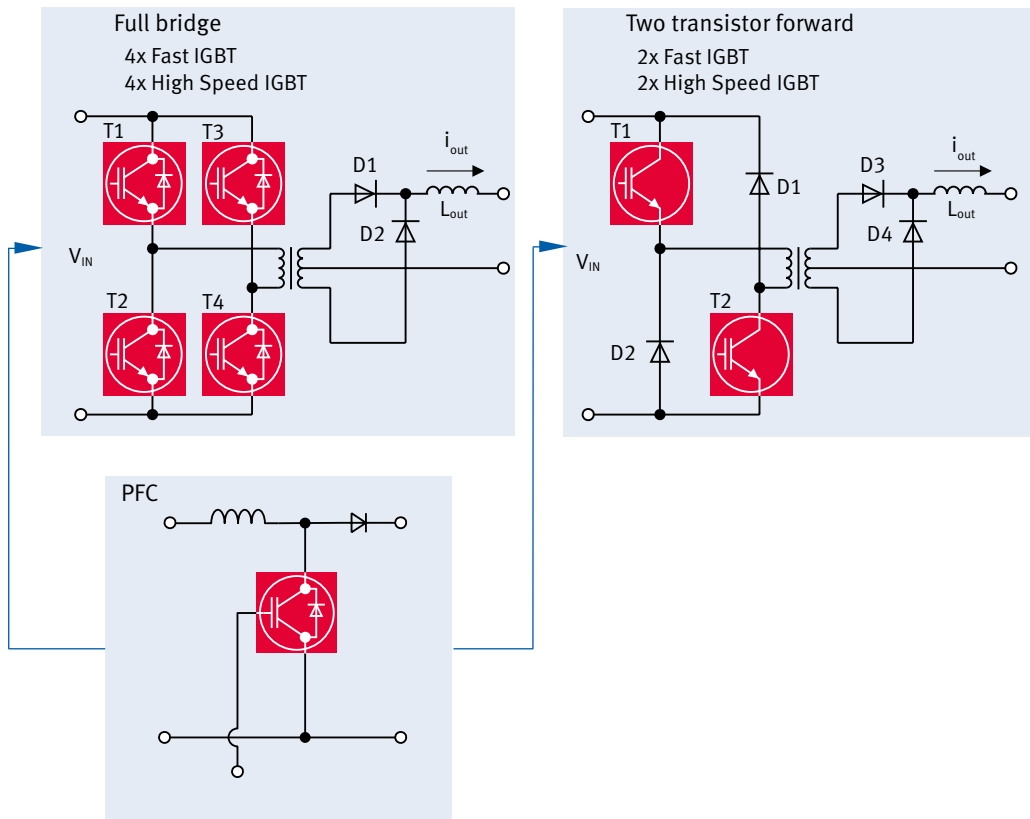

Industrial Welding	Topology	Voltage Class	Technology	Selection
DC/AC	Full-Bridge	600V	HighSpeed 3	Recommendation
	Full-Bridge	1200V	HighSpeed 3	Recommendation
	Two Transistor Forward	600V	HighSpeed 3	Recommendation
	Two Transistor Forward	1200V	HighSpeed 3	Recommendation
PFC AC/DC	Boost Converter / switch	600V	HighSpeed 3	Reference
	Boost Converter / switch	1200V	HighSpeed 3	Reference
Aux	Boost Converter	650V	CoolSET F3	Recommendation
IGBT Driver	Half-Bridge Single Channel	600V/1200V	EiceDRIVER™ (1ED)	Efficiency
	Half-Bridge Dual Channel	600V/1200V	EiceDRIVER™ ("ED)	Recommendation



# Induction Heating

## Highest Performance, Efficiency and Reliability IGBTs for Induction Heating Cooktops

Being the market leader in IGBTs, we offer a comprehensive, high performance portfolio of 600V, 1100V, 1200V, 1350V, 1600V discrete IGBTs for resonant-switching applications like induction heating cooktops. The portfolio has been developed to provide benchmark performance in terms of switching and conduction losses, which ensures best-in-class efficiency and fast time to market.

New Edition IHW40N60RF and 600V HighSpeed 3 family have been added to address high speed switching topologies where switching losses have been optimized. These devices provide excellent performance over temperature and ensure up to 20% lower switching losses compared to competitor devices.

The 1350V 3<sup>rd</sup> Generation induction heating specific IGBT has recently been added to the portfolio. The device has been designed to offer a higher voltage breakthrough headroom to offer customer higher reliability whilst not compromising device performance.

Induction Heating Inverter (Current Resonance)

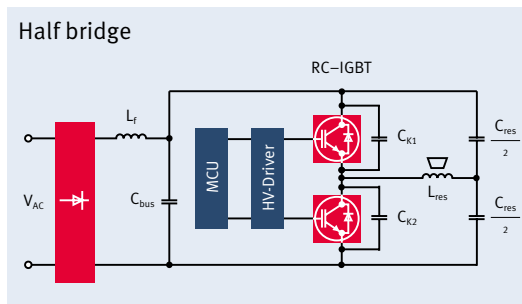

Induction Heating Inverter (Voltage Resonance)

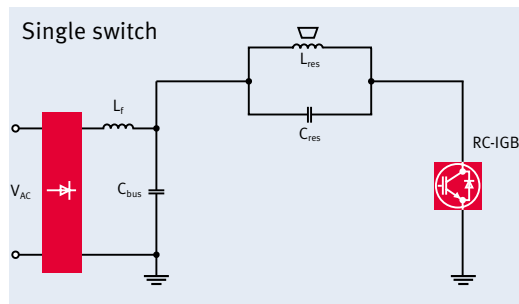

Induction Heating	Topology	Voltage Class	Technology	Selection
DC/AC	Series-Resonant Half-Bridge 20kHz	600V	RC-H	Recommendation
	Series-Resonant Half-Bridge 60kHz	600V	RC-HF	Recommendation
	Quasi-Resonant Single Ended	1100V	RC-H	Recommendation
	Quasi-Resonant Single Ended	1200V	RC-H	Reference
	Quasi-Resonant Single Ended	1350V	RC-H	Reference
	Quasi-Resonant Single Ended	1600V	RC-H	Recommendation
Aux	Flyback	650V	CoolSET QR	Efficiency
	Flyback	800V	CoolSET QR	Recommendation
	Boost Converter	800V	CoolSET F3	Reference



# Aircon

## Infineon's Innovative Approach for Aircon Reference Board

We offer a wide portfolio of energy saving chips for the whole system chain of power electronic devices for air-conditioning systems. To enable engineers a fast entry in the usage of our devices an aircon reference board has been developed.

### Features

- 1 kW compressor inverter stage using 15 A RC-Drives IGBT in DPAK (TO-252)
- 200 W outdoor fan inverter stage using 4 A RC-Drives IGBT in DPAK (TO-252)
- 1.5 kW CCM-PFC using 20 A HighSpeed 3 IGBT
- 10 A SiC-Diode

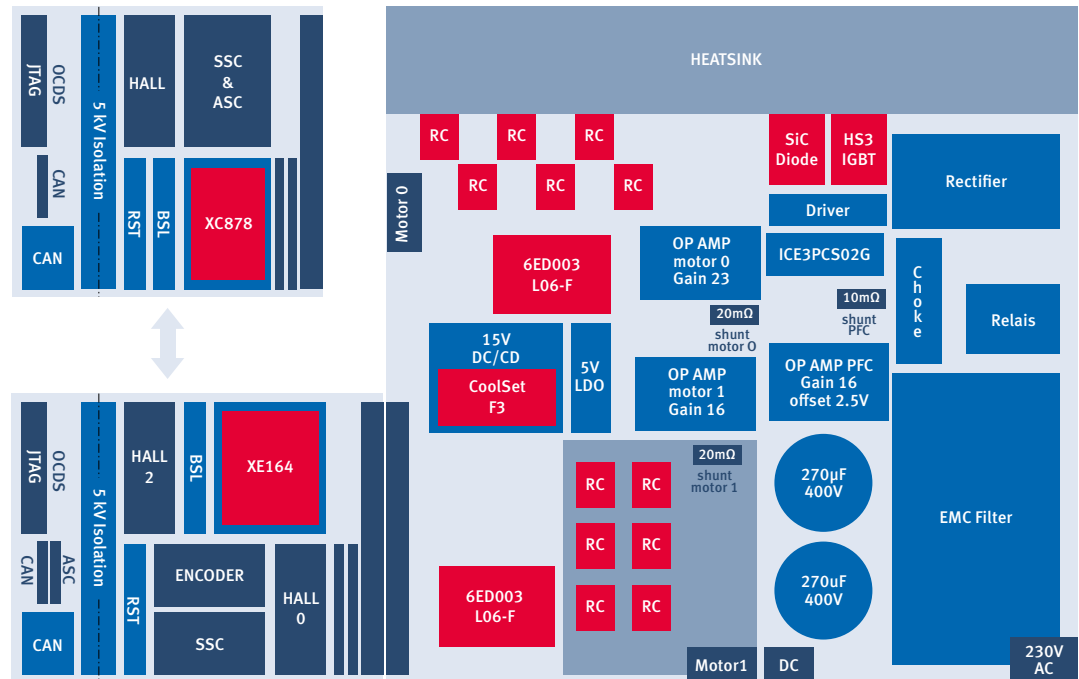

Aircon	Topology	Voltage Class	Technology	Selection
PFC AC / DC	PFC CCM (low frequency)	600V	TRENCHSTOP™	Recommendation
	PFC CCM (high frequency)	600V	HighSpeed 3	Recommendation
	PFC CCM	600V	CoolMOS™ C6	Reference
	PFC CCM	600V	SiC Diode	Recommendation
DC / AC	B6-VSI	600V	RC Drives	Recommendation
	B6-VSI	600V	TRENCHSTOP™	Efficiency
Aux	Boost Converter	650V	CoolSET™ F3	Reference
IGBT Driver	Driver for B6 Bridge	600V	EiceDRIVER™ (6ED)	Recommendation

# OptiMOS™

## Leading-edge solutions for a better future

Infineon's innovative products serve the market needs throughout the whole energy supply chain. OptiMOS™ is the market leader in highly efficient solutions for power generation (e.g. solar micro inverter), power supply (e.g. server and telecom) and power consumption (e.g. electric vehicle). In all these areas, our customers face the challenge of growing power demand, higher efficiency and lower cost. At the same time, the available space is constantly shrinking, leading to higher power density requirements.

The solution can be found in the low voltage Power MOSFET family, OptiMOS™ 20V up to 250V, which consistently sets the benchmark in key specifications for power system design, including leading on-state resistance and Figure of Merit characteristics which lead to reduced power losses and improved overall efficiency.

Lower power losses enable system cost improvement by reducing the need for device paralleling and allowing smaller heatsinks. OptiMOS™ family also contributes to customers' goals of providing more compact power supply designs.

Available in innovative space saving packages like CanPAK™, SuperSO8 or S308, these products reduce the volume consumption up to more than 90%. In addition, they improve switching noise and EMI for SMPS, as well as other industrial applications.

### OptiMOS™ products are suitable for a wide range of applications:

- VR-modules for server
- Synchronous rectification for AC/DC SMPS
- DC/DC converters
- Motor control 12V-110V system
- Solar micro inverter and Maximum Power Point Tracker (MPPT)
- LED lighting
- Notebook and desktop

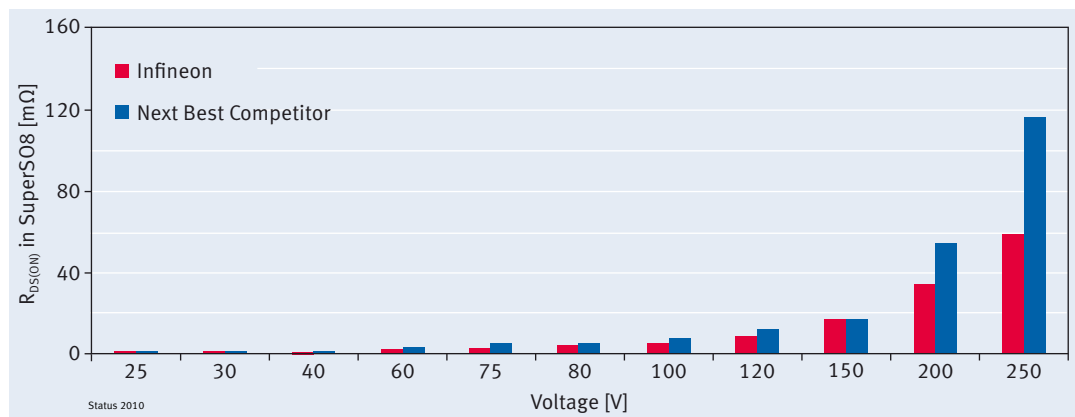

## Demonstrating > 93% efficiency in voltage regulation for power applications

With the new OptiMOS™ 25V and 30V product family, Infineon sets new standards in power density and Energy Efficiency for discrete power MOSFETs. Ultra low gate and output charge, together with lowest on-state resistance in small footprint packages, make OptiMOS™ 25V the best choice for the demanding requirements of voltage regulator solutions in servers, datacom and telecom applications. OptiMOS™ 30V products are tailored to the needs of power management in notebook by improved EMI behavior, as well as increased battery life.

With the new OptiMOS™ products, we have the best solution to

- Save overall system costs by reducing the number of phases in multiphase converters
- Reduce power losses and increase Efficiency for all load conditions
- Save space with smallest packages like CanPAK™ or S308
- Minimize EMI in the system making external snubber networks obsolete and the products easy to design-in

### Efficiency of OptiMOS™ 25V in a six-phase server VRD

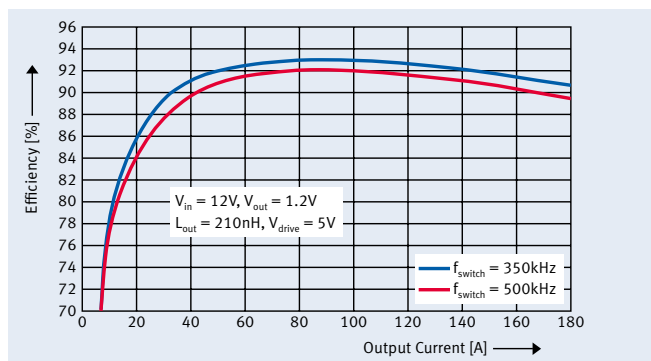

Outstanding performance of the new OptiMOS™ 25V and 30V products is exemplified on a six-phase Server  $V_{core}$  VRD. 93% peak efficiency and >90% full load efficiency is demonstrated with the new OptiMOS™ 25V products in SuperSO8 package.  
 (HighSide: BSC050NE2LS;  
 LowSide: BSC010NE2LS)

### Clean waveforms for optimized EMI behaviour make new OptiMOS™ 25V/30V products easy to use

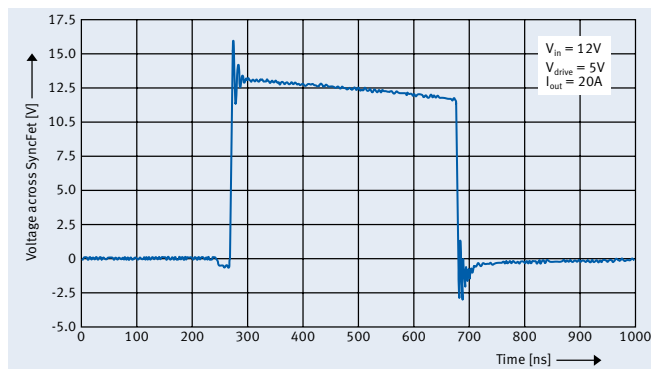

With the new OptiMOS™ 25V/30V products short switching times (rise and fall times <5ns) go in hand with excellent EMI behaviour. An integrated damping network guarantees low over- and undershoot and minimizes ringing without sacrificing efficiency

## Always a step ahead with Infineon

With OptiMOS™ 40V-250V products, we set the benchmark in industry. The leading on-state resistance  $R_{DS(ON)}$  and switching behaviour reduce power losses and enable overall efficiency levels exceeding 95%. With these products Infineon supports the market trend towards Energy Efficiency targets such as Energy Star Diamond.

OptiMOS™ technology enables for the first time very low  $R_{DS(ON)}$  values needed for high current applications in space saving packages such as SuperSO8, S308 and CanPAK™, which were previously only possible in bulky packages.

Efficiency

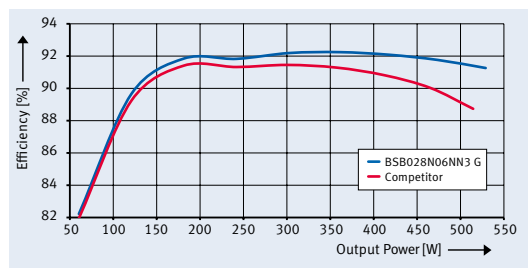

More than 1% higher peak efficiency can be reached by using Infineon products in synchronous rectification of a 600W Server power supply with 12V output.



## SuperSO8 / S308 – the intelligent way to highest efficiency and power density

In applications like synchronous rectification in SMPS, motor drives and DC/DC converters, high power density and high efficiency are the major driving factors. Moving from TO-220 to SuperSO8 reduces the volume consumption drastically. With three times lower parasitics compared to TO-220, SuperSO8 offers highest efficiency and lowest design efforts due to reduced spikes.



## CanPAK™ – best thermal behaviour in a tiny footprint

CanPAK™ portfolio is the best fit for a broad number of industrial applications like voltage regulator for servers, DC/DC converters, solar micro inverters and Maximum Power Point Trackers (MPPT), low voltage drives and synchronous rectification. With only 31mm<sup>2</sup> footprint, CanPAK™ M allows 65% space reduction in power components on the board compared to traditional D<sup>2</sup>PAK. In addition, the metal ‘Can’ enables double-sided cooling along with almost no package parasitic inductances, leading to higher systems efficiency.



## PowerStage3x3 – optimized for highest power density

The new package PowerStage 3x3, is a leadless SMD package, which integrates the low-side and high-side MOSFET of a synchronous DC/DC converter into a 3x3mm<sup>2</sup> package outline with only 0.8 mm package height. It is designed for an optimized thermal behaviour for DC/DC converters as well as for a compact layout on the PCB. With its high current capability [max. continuous current 25 A ( $T_{case} = 70^{\circ}C$ ), max. pulse current 40 A ( $T_{case} = 25^{\circ}C$ )] the PowerStage 3x3 is the best solution to enhance performance levels in smaller form factors than any other previous generations.

## OptiMOS™ 20V



$R_{DS(on)}$ @ $V_{GS}=10V$ [mΩ]	TO-251 / TO-251 SL	TO-252 DPAK	CanPAK™ M	CanPAK™ S	TO-263 7 Pin	TO-220	TO-220 FullPAK	SuperSO8	S308
<2									BSC019N02KS G $R_{DS(on)} = 1.9m\Omega$
2-4									BSC026N02KS G $R_{DS(on)} = 2.6m\Omega$
4-10									BSC046N02KS G $R_{DS(on)} = 4.6m\Omega$
30-40								BSO330N02K G $R_{DS(on)} = 32.0m\Omega$	

## OptiMOS™ 25V



$R_{DS(on)}$ @ $V_{GS}=10V$ [mΩ]	TO-251 / TO-251 SL	TO-252 DPAK	CanPAK™ M	CanPAK™ S	TO-263 7 Pin	TO-220	TO-220 FullPAK	SuperSO8	S308
<1.0			BSB008NE2LS * $R_{DS(on)} = 0.8m\Omega$					BSC009NE2LS $R_{DS(on)} = 0.9m\Omega$	
1-2			BSB012NE2LX $R_{DS(on)} = 1.2m\Omega$					BSC010NE2LS $R_{DS(on)} = 1.0m\Omega$	BSZ18NE2LS $R_{DS(on)} = 1.8m\Omega$
			BSB013NE2LXI $R_{DS(on)} = 1.3m\Omega$					BSC010NE2LSI $R_{DS(on)} = 1.0m\Omega$	BSZ018NE2LSI $R_{DS(on)} = 1.8m\Omega$
								BSC014NE2LSI $R_{DS(on)} = 1.4m\Omega$	
								BSC018NE2LSI $R_{DS(on)} = 1.8m\Omega$	
2-4								BSC018NE2LS $R_{DS(on)} = 1.8m\Omega$	
								BSC024NE2LS $R_{DS(on)} = 2.4m\Omega$	
4-6				BSF030NE2LQ $R_{DS(on)} = 3.0m\Omega$				BSC032NE2LS $R_{DS(on)} = 3.2m\Omega$	BSZ036NE2LS $R_{DS(on)} = 3.6m\Omega$
								BSC050NE2LS $R_{DS(on)} = 5m\Omega$	
									BSZ060NE2LS $R_{DS(on)} = 6m\Omega$

\* in development  
All OptiMOS™ products are halogen free.

# OptiMOS™ 30V Logic Level



$R_{DS(on)}$ @ $V_{GS}=10V$ [mΩ]	TO-251 / TO-251 SL	TO-252 DPAK	CanPAK™ M	CanPAK™ S	TO-263 D <sup>2</sup> PAK	TO-263 7 Pin	TO-220	S308 - dual (Power Stage 3x3)	Super SO8	S308	Bare Die ( $R_{DS(on)}$ typ.)
1-2			BSB012N03LX3 G $R_{DS(on)}=1.2m\Omega$			IPB009N03L G $R_{DS(on)}=0.95m\Omega$			BSC011N03LS $R_{DS(on)}=1.1m\Omega$		IPC218N03L3
									BSC014N03LS G $R_{DS(on)}=1.4m\Omega$		
			BSB017N03LX3 G $R_{DS(on)}=1.7m\Omega$						BSC016N03LS G $R_{DS(on)}=1.6m\Omega$	BSZ019N03LS $R_{DS(on)}=1.9m\Omega$	IPC055N03L3
									BSC0901NS $R_{DS(on)}=1.9m\Omega$		
2-4				BSF024N03LT3 G $R_{DS(on)}=2.4m\Omega$					BSC020N03LS G $R_{DS(on)}=2.0m\Omega$	BSZ0901NSI $R_{DS(on)}=2.1m\Omega$	IPC042N03L3
									BSC0902NSI $R_{DS(on)}=2.8m\Omega$	BSZ0902NSI $R_{DS(on)}=2.8m\Omega$	
									BSC025N03LS G $R_{DS(on)}=2.5m\Omega$	BSZ0902NS $R_{DS(on)}=2.6m\Omega$	
									BSC0902NS $R_{DS(on)}=2.6m\Omega$		
	IPS031N03L G $R_{DS(on)}=3.1m\Omega$	IPD031N03L G $R_{DS(on)}=3.1m\Omega$			IPB034N03L G $R_{DS(on)}=3.4m\Omega$		IPPO34N03L G $R_{DS(on)}=3.4m\Omega$		BSC030N03LS G $R_{DS(on)}=3.0m\Omega$	BSZ035N03LS G $R_{DS(on)}=3.5m\Omega$	
									BSC034N03LS G $R_{DS(on)}=3.4m\Omega$	BSZ0904NSI $R_{DS(on)}=4.0m\Omega$	
4-6	IPS040N03L G $R_{DS(on)}=4.0m\Omega$	IPD040N03L G $R_{DS(on)}=4.0m\Omega$		BSF050N03LQ3 G $R_{DS(on)}=5.0m\Omega$	IPB042N03L G $R_{DS(on)}=4.2m\Omega$		IPPO42N03L G $R_{DS(on)}=4.2m\Omega$		BSC042N03LS G $R_{DS(on)}=4.2m\Omega$	BSZ050N03LS G $R_{DS(on)}=5.0m\Omega$	IPC028N03L3 IPC022N03L3
	IPS050N03L G $R_{DS(on)}=5.0m\Omega$	IPD050N03L G $R_{DS(on)}=5.0m\Omega$			IPB055N03L G $R_{DS(on)}=5.5m\Omega$		IPPO55N03L G $R_{DS(on)}=5.5m\Omega$		BSC0906NS $R_{DS(on)}=4.5m\Omega$	BSZ058N03LS G $R_{DS(on)}=5.8m\Omega$	
									BSC050N03LS G $R_{DS(on)}=5.0m\Omega$		
									BSC057N03LS G $R_{DS(on)}=5.7m\Omega$		
									BSC052N03LS $R_{DS(on)}=5.2m\Omega$		
6-8	IPS060N03L G $R_{DS(on)}=6.0m\Omega$	IPD060N03L G $R_{DS(on)}=6.0m\Omega$			IPB065N03L G $R_{DS(on)}=6.5m\Omega$		IPPO65N03L G $R_{DS(on)}=6.5m\Omega$			BSZ065N03LS $R_{DS(on)}=6.5m\Omega$	
	IPS075N03L G $R_{DS(on)}=7.5m\Omega$	IPD075N03L G $R_{DS(on)}=7.5m\Omega$			IPB080N03L G $R_{DS(on)}=8.0m\Omega$		IPPO80N03L G $R_{DS(on)}=8.0m\Omega$		BSC0908NS $R_{DS(on)}=8.0m\Omega$		

All OptiMOS™ products are halogen free.

# OptiMOS™ 30V Logic Level



$R_{DS(on)}$ @ $V_{GS}=10V$ [mΩ]	TO-251 / TO-251 SL	TO-252 DPAK	CanPAK™ M	CanPAK™ S	TO-263 D <sup>2</sup> PAK	TO-263 7 Pin	TO-220	S308 - dual (Power Stage 3x3)	Super SO8	S308	Bare Die ( $R_{DS(on)}$ typ.)
8-10	IPS090N03L G $R_{DS(on)}=9.0m\Omega$	IPD090N03L G $R_{DS(on)}=9.0m\Omega$			IPB096N03L G $R_{DS(on)}=9.6m\Omega$		IPP096N03L G $R_{DS(on)}=9.6m\Omega$		BSC080N03LS G $R_{DS(on)}=8.0m\Omega$	BSZ088N03LS G $R_{DS(on)}=8.8m\Omega$	
								BSC090N03LS G $R_{DS(on)}=9.0m\Omega$	BSZ0905NS * $R_{DS(on)}=9.0m\Omega$		
									BSC0909NS $R_{DS(on)}=9.2m\Omega$		
10-15	IPS105N03L G $R_{DS(on)}=10.5m\Omega$	IPD105N03L G $R_{DS(on)}=10.5m\Omega$			IPB114N03L G $R_{DS(on)}=11.4m\Omega$		IPP114N03L G $R_{DS(on)}=11.4m\Omega$		BSC100N03LS G $R_{DS(on)}=10.0m\Omega$	BSZ100N03LS G $R_{DS(on)}=10.0m\Omega$	IPC014N03L3
										BSZ0909NS $R_{DS(on)}=12.0m\Omega$	
	IPS135N03L G $R_{DS(on)}=13.5m\Omega$	IPD135N03L G $R_{DS(on)}=13.5m\Omega$			IPB147N03L G $R_{DS(on)}=14.7m\Omega$		IPP147N03L G $R_{DS(on)}=14.7m\Omega$			BSZ130N03LS G $R_{DS(on)}=13.0m\Omega$	
15-20										BSZ0920NS * $R_{DS(on)}=18.0m\Omega$	
7 + 9								BSZ0907ND * $R_{DS(on)}=9.5/7.2m\Omega$			
9 + 19								BSZ0908ND * $R_{DS(on)}=19.0/9.0m\Omega$			
2 x 7.2									BSC072N03LD G $R_{DS(on)}=7.2m\Omega$		
2 x 15									BSC150N03LD G $R_{DS(on)}=15.0m\Omega$		

\* in development  
All OptiMOS™ products are halogen free.

# OptiMOS™ 30V Enhanced Logic Level



$R_{DS(on)}$ @ $V_{GS}=10V$ [mΩ]	TO-251 / TO-251 SL	TO-252 DPAK	S308	TO-263 D <sup>2</sup> PAK	TO-263 7 Pin	TO-220	TO-220 FullPAK	SuperS08	S08
<2								BSC014N03MS G $R_{DS(on)}=1.4m\Omega$	
								BSC016N03MS G $R_{DS(on)}=1.6m\Omega$	
2-6			BSZ035N03MS G $R_{DS(on)}=3.5m\Omega$					BSC020N03MS G $R_{DS(on)}=2.0m\Omega$	BSO033N03MS G $R_{DS(on)}=3.3m\Omega$
								BSC025N03MS G $R_{DS(on)}=2.5m\Omega$	BSO040N03MS G $R_{DS(on)}=4.0m\Omega$
								BSC030N03MS G $R_{DS(on)}=3.0m\Omega$	
			BSZ050N03MS G $R_{DS(on)}=5.0m\Omega$					BSC042N03MS G $R_{DS(on)}=4.2m\Omega$	BSO051N03MS G $R_{DS(on)}=5.1m\Omega$
			BSZ058N03MS G $R_{DS(on)}=5.8m\Omega$					BSC050N03MS G $R_{DS(on)}=5.0m\Omega$	
								BSC057N03MS G $R_{DS(on)}=5.7m\Omega$	
6-10									BSO065N03MS G $R_{DS(on)}=6.5m\Omega$
			BSZ088N03MS G $R_{DS(on)}=8.8m\Omega$					BSC080N03MS G $R_{DS(on)}=8.0m\Omega$	BSO083N03MS G $R_{DS(on)}=8.3m\Omega$
								BSC090N03MS G $R_{DS(on)}=9.0m\Omega$	
10-20			BSZ100N03MS G $R_{DS(on)}=10.0m\Omega$					BSC100N03MS G $R_{DS(on)}=10.0m\Omega$	BSO110N03MS G $R_{DS(on)}=11.0m\Omega$
			BSZ130N03MS G $R_{DS(on)}=13.0m\Omega$					BSC120N03MS G $R_{DS(on)}=12.0m\Omega$	BSO130N03MS G $R_{DS(on)}=13.0m\Omega$
>20								BSO220N03MS G $R_{DS(on)}=22.0m\Omega$	
2 x 15								BSO150N03MD G $R_{DS(on)}=15.0m\Omega$	
2 x 22								BSO220N03MD G $R_{DS(on)}=22.0m\Omega$	

Low Voltage

All OptiMOS™ products are halogen free.

## OptiMOS™ 40V Logic Level / Normal Level



$R_{DS(on)}$ @ $V_{GS}=10V$ [mΩ]	TO-252 DPAK	CanPAK™ M	TO-263 D <sup>2</sup> PAK	TO-263 7 Pin	TO-220	TO-220 FullPAK	Super SO8	S308	Bare Die ( $R_{DS(on)}$ typ.)
<2		BSB014N04LX3 G $R_{DS(on)}=1.4m\Omega$	IPB015N04N G $R_{DS(on)}=1.4m\Omega$	IPB011N04L G $R_{DS(on)}=1.1m\Omega$	IPP015N04N G $R_{DS(on)}=1.5m\Omega$		BSC016N04LS G $R_{DS(on)}=1.6m\Omega$		IPC218N04N3 IPC171N04N
		BSB015N04NX3 G $R_{DS(on)}=1.5m\Omega$	IPB015N04L G $R_{DS(on)}=1.5m\Omega$	IPB011N04N G $R_{DS(on)}=1.1m\Omega$			BSC017N04NS G $R_{DS(on)}=1.7m\Omega$		
							BSC018N04LS G $R_{DS(on)}=1.8m\Omega$		
							BSC019N04NS G $R_{DS(on)}=1.9m\Omega$		
2-3			IPB022N04L G $R_{DS(on)}=2.2m\Omega$	IPB020N04N G $R_{DS(on)}=2.0m\Omega$	IPP023N04N G $R_{DS(on)}=2.3m\Omega$		BSC027N04LS G $R_{DS(on)}=2.7m\Omega$		
			IPB023N04N G $R_{DS(on)}=2.3m\Omega$				BSC030N04NS G $R_{DS(on)}=3.0m\Omega$		
3-4	IPD036N04L G $R_{DS(on)}=3.6m\Omega$		IPB039N04L G $R_{DS(on)}=3.9m\Omega$		IPPO39N04L G $R_{DS(on)}=3.9m\Omega$		BSC035N04LS G $R_{DS(on)}=3.5m\Omega$	BSZ040N04LS G $R_{DS(on)}=4.0m\Omega$	
	IPD038N04N G $R_{DS(on)}=3.8m\Omega$		IPD038N04N G $R_{DS(on)}=3.8m\Omega$						
4-7			IPB052N04N G $R_{DS(on)}=5.2m\Omega$		IPP041N04N G $R_{DS(on)}=4.1m\Omega$		BSC050N04LS G $R_{DS(on)}=5.0m\Omega$	BSZ042N04NS G $R_{DS(on)}=4.2m\Omega$	
					IPP048N04N G $R_{DS(on)}=4.8m\Omega$		BSC054N04NS G $R_{DS(on)}=5.4m\Omega$		
					IPP065N04N G $R_{DS(on)}=6.5m\Omega$		BSC059N04LS G $R_{DS(on)}=5.9m\Omega$		
7-8			IPB075N04L G $R_{DS(on)}=7.5m\Omega$						
8-10	IPD088N04L G $R_{DS(on)}=8.8m\Omega$		IPB093N04L G $R_{DS(on)}=9.3m\Omega$				BSC093N04LS G $R_{DS(on)}=9.3m\Omega$	BSZ097N04LS G $R_{DS(on)}=9.7m\Omega$	
10-11	IPD105N04L G $R_{DS(on)}=10.5m\Omega$							BSZ105N04NS G $R_{DS(on)}=10.5m\Omega$	
13-17	IPD160N04L G $R_{DS(on)}=16m\Omega$							BSZ165N04NS G $R_{DS(on)}=16.5m\Omega$	
	IPD170N04N G $R_{DS(on)}=17m\Omega$								

All OptiMOS™ products are halogen free.

# OptiMOS™ 60V Logic Level / Normal Level



$R_{DS(on)}$ @ $V_{GS}=10V$ [mΩ]	TO-252 DPAK	CanPAK™ M	CanPAK™ S	TO-262	TO-263 D <sup>2</sup> PAK	TO-263 7 Pin	TO-220	TO-220 FullPAK	Super SO8	S308	Bare Die ( $R_{DS(on)}$ typ.)
<3		BSB028N06NN3 G $R_{DS(on)}=2.8m\Omega$		IPI024N06N3 G $R_{DS(on)}=2.4m\Omega$	IPB019N06L3 G $R_{DS(on)}=1.9m\Omega$	IPB016N06LS3 G $R_{DS(on)}=1.6m\Omega$	IPPO24N06N3 G $R_{DS(on)}=2.4m\Omega$				IPC218N06L3
					IPB021N06N3 G $R_{DS(on)}=2.1m\Omega$	IPB017N06N3 G $R_{DS(on)}=1.7m\Omega$			BSC028N06LS3 G $R_{DS(on)}=2.8m\Omega$		IPC218N06N3
					IPB029N06N3 G $R_{DS(on)}=2.9m\Omega$	IPB023N06N3 G $R_{DS(on)}=2.3m\Omega$					
3-5	IPD031N06L3 G $R_{DS(on)}=3.1m\Omega$			IPI032N06N3 G $R_{DS(on)}=3.2m\Omega$	IPB034N06L3 G $R_{DS(on)}=3.4m\Omega$	IPB034N06N3 G $R_{DS(on)}=3.4m\Omega$	IPPO32N06N3 G $R_{DS(on)}=3.2m\Omega$	IPA032N06N3 G $R_{DS(on)}=3.2m\Omega$	BSC031N06NS3 G $R_{DS(on)}=3.1m\Omega$		
	IPD034N06N3 G $R_{DS(on)}=3.4m\Omega$			IPI037N06L3 G $R_{DS(on)}=3.7m\Omega$	IPB037N06N3 G $R_{DS(on)}=3.7m\Omega$		IPPO37N06L3 G $R_{DS(on)}=3.7m\Omega$				
	IPD035N06L3 G $R_{DS(on)}=3.5m\Omega$			IPI040N06N3 G $R_{DS(on)}=4.0m\Omega$	IPB049N06L3 G $R_{DS(on)}=4.9m\Omega$		IPPO40N06N3 G $R_{DS(on)}=4.0m\Omega$				
	IPD048N06L3 G $R_{DS(on)}=4.8m\Omega$										
	IPD038N06N3 G $R_{DS(on)}=3.8m\Omega$										
5-7	IPD053N06N3 G $R_{DS(on)}=5.3m\Omega$				IPB054N06N3 G $R_{DS(on)}=5.4m\Omega$		IPPO52N06L3 G $R_{DS(on)}=5.2m\Omega$	IPA057N06N3 G $R_{DS(on)}=5.7m\Omega$			
							IPPO57N06N3 G $R_{DS(on)}=5.7m\Omega$		BSC067N06LS3 G $R_{DS(on)}=6.7m\Omega$	BSZ067N06LS3 G $R_{DS(on)}=6.7m\Omega$	
7-10	IPD079N06L3 G $R_{DS(on)}=7.9m\Omega$		BSF077N06NT3 G $R_{DS(on)}=7.7m\Omega$		IPB081N06L3 G $R_{DS(on)}=8.1m\Omega$		IPPO84N06L3 G $R_{DS(on)}=8.4m\Omega$	IPA093N06N3 G $R_{DS(on)}=9.3m\Omega$	BSC076N06NS3 G $R_{DS(on)}=7.6m\Omega$	BSZ076N06NS3 G $R_{DS(on)}=7.6m\Omega$	
	IPD088N06N3 G $R_{DS(on)}=8.8m\Omega$				IPB090N06N3 G $R_{DS(on)}=9.0m\Omega$		IPPO93N06N3 G $R_{DS(on)}=9.3m\Omega$		BSC100N06LS3 G $R_{DS(on)}=10.0m\Omega$	BSZ100N06LS3 G $R_{DS(on)}=10.0m\Omega$	
11-30	IPD220N06L3 G $R_{DS(on)}=22.0m\Omega$				IPB230N06L3 G $R_{DS(on)}=23.0m\Omega$		IPPP230N06L3 G $R_{DS(on)}=23.0m\Omega$		BSC110N06NS3 G $R_{DS(on)}=11.0m\Omega$	BSZ110N06NS3 G $R_{DS(on)}=11.0m\Omega$	
	IPD250N06N3 G $R_{DS(on)}=25.0m\Omega$				IPB260N06N3 G $R_{DS(on)}=26.0m\Omega$		IPPP260N06N3 G $R_{DS(on)}=26.0m\Omega$				
30-50	IPD350N06L G $R_{DS(on)}=35.0m\Omega$										
	IPD400N06N G $R_{DS(on)}=40.0m\Omega$										
	IPD640N06L G $R_{DS(on)}=64.0m\Omega$										
50-80	IPD800N06L G $R_{DS(on)}=80.0m\Omega$										
	IPD800N06N G $R_{DS(on)}=80.0m\Omega$										

Low Voltage

All OptiMOS™ products are halogen free.

## OptiMOS™ 75V Normal Level



$R_{DS(on)}$ @ $V_{GS}=10V$ [mΩ]	TO-252 DPAK	TO-262	TO-263 D <sup>2</sup> PAK	TO-263 7 Pin	TO-220	TO-220 FullPAK	Super SO8	S308	Bare Die ( $R_{DS(on)}$ typ.)
2-4		IPI023NE7N3 G $R_{DS(on)}=2.3m\Omega$	IPB031NE7N3 G $R_{DS(on)}=3.1m\Omega$		IPP023NE7N3 G $R_{DS(on)}=2.3m\Omega$				IPC302NE7N3
		IPI034NE7N3 G $R_{DS(on)}=3.4m\Omega$	IPB020NE7N3 G $R_{DS(on)}=2m\Omega$		IPP034NE7N3 G $R_{DS(on)}=3.4m\Omega$				
4-6		IPI052NE7N3 G $R_{DS(on)}=5.2m\Omega$	IPB049NE7N3 G $R_{DS(on)}=4.9m\Omega$		IPP052NE7N3 G $R_{DS(on)}=5.2m\Omega$		BSC042NE7NS3 G $R_{DS(on)}=4.2m\Omega$		
6-12					IPP062NE7N3 G $R_{DS(on)}=6.2m\Omega$				

All OptiMOS™ products are halogen free.

# OptiMOS™ 80V



$R_{DS(on)}$ @ $V_{GS}=10V$ [mΩ]	TO-251 / TO-251 SL	TO-252 DPAK	CanPAK™ M	TO-262	TO-263 D <sup>2</sup> PAK	TO-263 7 Pin	TO-220	TO-220 FullPAK	Super SO8	S308	Bare Die ( $R_{DS(on)}$ typ.)
1-3						IPB019N08N3 G $R_{DS(on)}=1.9m\Omega$					IPC302N08N3
				IPI028N08N3 G $R_{DS(on)}=2.8m\Omega$	IPB025N08N3 G $R_{DS(on)}=2.5m\Omega$		IPPO28N08N3 G $R_{DS(on)}=2.8m\Omega$	IPA028N08N3 G $R_{DS(on)}=2.8m\Omega$			
3-4				IPI037N08N3 G $R_{DS(on)}=3.7m\Omega$	IPB035N08N3 G $R_{DS(on)}=3.5m\Omega$	IPB030N08N3 G $R_{DS(on)}=3.0m\Omega$	IPPO37N08N3 G $R_{DS(on)}=3.7m\Omega$	IPA037N08N3 G $R_{DS(on)}=3.7m\Omega$			
4-6		IPD053N08N3 G $R_{DS(on)}=5.3m\Omega$	BSB044N08N3 G $R_{DS(on)}=4.4m\Omega$	IPI057N08N3 G $R_{DS(on)}=5.7m\Omega$	IPB054N08N3 G $R_{DS(on)}=5.4m\Omega$		IPPO57N08N3 G $R_{DS(on)}=5.7m\Omega$	IPA057N08N3 G $R_{DS(on)}=5.7m\Omega$	BSC047N08NS3 G $R_{DS(on)}=4.7m\Omega$		
									BSC057N08NS3 G $R_{DS(on)}=5.7m\Omega$		
6-7				IPI070N08N3 G $R_{DS(on)}=7.0m\Omega$	IPB067N08N3 G $R_{DS(on)}=6.7m\Omega$		IPPO70N08N3 G $R_{DS(on)}=7.0m\Omega$				
7-11		IPD096N08N3 G $R_{DS(on)}=9.6m\Omega$		IPI100N08N3 G $R_{DS(on)}=10m\Omega$	IPB097N08N3 G $R_{DS(on)}=9.7m\Omega$		IPPO97N08N3 G $R_{DS(on)}=9.7m\Omega$	IPA100N08N3 G $R_{DS(on)}=10.0m\Omega$			
11-20	IPI135N08N3 G $R_{DS(on)}=13.5m\Omega$	IPD135N08N3 G $R_{DS(on)}=13.5m\Omega$		IPI139N08N3 G $R_{DS(on)}=13.9m\Omega$	IPB136N08N3 G $R_{DS(on)}=13.6m\Omega$		IPPO139N08N3 G $R_{DS(on)}=13.9m\Omega$		BSC123N08NS3 G $R_{DS(on)}=12.3m\Omega$	BSZ123N08NS3 G $R_{DS(on)}=12.3m\Omega$	
30-40									BSC340N08NS3 G $R_{DS(on)}=34.0m\Omega$	BSZ340N08NS3 G $R_{DS(on)}=34.0m\Omega$	

Low Voltage

All OptiMOS™ products are halogen free.

# OptiMOS™ 100V Logic Level / Normal Level



$R_{DS(on)}$ @ $V_{GS}=10V$ [mΩ]	TO-251 / TO-251 SL	TO-252 DPAK	CanPAK™ M	CanPAK™ S	TO-262	TO-263 D²PAK	TO-263 7 Pin	TO-220	TO-220 FullPAK	Super SO8	S308	Bare Die ( $R_{DS(on)}$ typ.)	
<3					IPI030N10N3 G $R_{DS(on)}=3.0m\Omega$	IPB027N10N3 G $R_{DS(on)}=2.7m\Omega$	IPB025N10N3 G $R_{DS(on)}=2.5m\Omega$	IPP030N10N3 G $R_{DS(on)}=3.0m\Omega$	IPA030N10N3 G $R_{DS(on)}=3.0m\Omega$			IPC302N10N3 IPC26N10NR	
3-4							IPB039N10N3 G $R_{DS(on)}=3.9m\Omega$						
4-6			BSB056N10NN3 G $R_{DS(on)}=5.6m\Omega$		IPI045N10N3 G $R_{DS(on)}=4.5m\Omega$	IPB042N10N3 G $R_{DS(on)}=4.2m\Omega$		IPP045N10N3 G $R_{DS(on)}=4.5m\Omega$	IPA045N10N3 G $R_{DS(on)}=4.5m\Omega$				
6-8		IPD068N10N3 G $R_{DS(on)}=6.8m\Omega$			IPI072N10N3 G $R_{DS(on)}=7.2m\Omega$			IPP072N10N3 G $R_{DS(on)}=7.2m\Omega$			BSC060N10NS3 G $R_{DS(on)}=6.0m\Omega$		
								IPP06CN10L G $R_{DS(on)}=6.2m\Omega$			BSC070N10NS3 G $R_{DS(on)}=7.0m\Omega$		
8-12	IPS118N10N G $R_{DS(on)}=11.8m\Omega$	IPD082N10N3 G $R_{DS(on)}=8.2m\Omega$			IPI086N10N3 G $R_{DS(on)}=8.6m\Omega$	IPB083N10N3 G $R_{DS(on)}=8.3m\Omega$		IPP086N10N3 G $R_{DS(on)}=8.6m\Omega$	IPA086N10N3 G $R_{DS(on)}=8.5m\Omega$		BSC109N10NS3 G $R_{DS(on)}=10.9m\Omega$		
	IPS12CN10L G $R_{DS(on)}=11.8m\Omega$							IPP08CN10L G $R_{DS(on)}=8.0m\Omega$			BSC082N10LS G $R_{DS(on)}=8.2m\Omega$		
								IPP12CN10L G $R_{DS(on)}=12.0m\Omega$			BSC105N10LSF G $R_{DS(on)}=10.5m\Omega$		
12-18		IPD122N10N3 G $R_{DS(on)}=12.2m\Omega$		BSF134N10N3 G $R_{DS(on)}=13.4m\Omega$	IPI126N10N3 G $R_{DS(on)}=12.6m\Omega$	IPB123N10N3 G $R_{DS(on)}=12.3m\Omega$		IPP126N10N3 G $R_{DS(on)}=12.6m\Omega$	IPA126N10N3 G $R_{DS(on)}=12.6m\Omega$		BSC160N10NS3 G $R_{DS(on)}=16.0m\Omega$	BSZ160N10NS3 G $R_{DS(on)}=16.0m\Omega$	
								IPP16CN10L G $R_{DS(on)}=15.7m\Omega$			BSC123N10LS G $R_{DS(on)}=12.3m\Omega$		
											BSC159N10LSF G $R_{DS(on)}=15.9m\Omega$		
18-20		IPD180N10N3 G $R_{DS(on)}=18.0m\Omega$			IPI180N10N3 G $R_{DS(on)}=18.0m\Omega$			IPP180N10N3 G $R_{DS(on)}=18.0m\Omega$	IPA180N10N3 G $R_{DS(on)}=18.0m\Omega$				
20-40		IPD25CN10N G $R_{DS(on)}=25.0m\Omega$				IPB26CN10N G $R_{DS(on)}=26.0m\Omega$						BSC205N10LS G $R_{DS(on)}=20.5m\Omega$	
		IPD33CN10N G $R_{DS(on)}=33.0m\Omega$				IPB34CN10N G $R_{DS(on)}=34.0m\Omega$						BSC265N10LSF G $R_{DS(on)}=26.5m\Omega$	
40-80						IPB50CN10N G $R_{DS(on)}=50.0m\Omega$						BSC440N10NS3 G $R_{DS(on)}=44.0m\Omega$	BSZ440N10NS3 G $R_{DS(on)}=44.0m\Omega$
		IPD78CN10N G $R_{DS(on)}=78.0m\Omega$										BSC750N10ND G $R_{DS(on)}=75.0m\Omega$	

All OptiMOS™ products are halogen free.

## OptiMOS™ 120V



$R_{DS(on)}$ @ $V_{GS}=10V$ [mΩ]	TO-251 / TO-251 SL	TO-252 DPAK	TO-262	TO-263 D <sup>2</sup> PAK	TO-263 7 Pin	TO-220	Super SO8	S308	Bare Die ( $R_{DS(on)}$ typ.)
<4				IPB038N12N3 G $R_{DS(on)}=3.8m\Omega$	IPB036N12N3 G $R_{DS(on)}=3.6m\Omega$				IPC302N12N3 IPC26N12N
4-5			IPI041N12N3 G $R_{DS(on)}=4.1m\Omega$			IPPO41N12N3 G $R_{DS(on)}=4.1m\Omega$			
			IPI048N12N3 G $R_{DS(on)}=4.8m\Omega$			IPPO48N12N3 G $R_{DS(on)}=4.8m\Omega$			
7-8			IPI076N12N3 G $R_{DS(on)}=7.6m\Omega$			IPPO76N12N3 G $R_{DS(on)}=7.6m\Omega$	BSC077N12NS3 G $R_{DS(on)}=7.7m\Omega$		
10-13	IPS110N12N3 G $R_{DS(on)}=11.0m\Omega$	IPD110N12N3 G $R_{DS(on)}=11.0m\Omega$				IPP114N12N3 G $R_{DS(on)}=11.4m\Omega$			
13-20			IPI147N12N3 G $R_{DS(on)}=14.7m\Omega$	IPB144N12N3 G $R_{DS(on)}=14.4m\Omega$		IPP147N12N3 G $R_{DS(on)}=14.7m\Omega$	BSC190N12NS3 G $R_{DS(on)}=19.0m\Omega$		
20-25							BSC240N12NS3 G $R_{DS(on)}=24.0m\Omega$	BSZ240N12NS3 G $R_{DS(on)}=24.0m\Omega$	

## OptiMOS™ 150V



$R_{DS(on)}$ @ $V_{GS}=10V$ [mΩ]	TO-252 DPAK	CanPAK™ M	TO-262	TO-263 D <sup>2</sup> PAK	TO-263 7 Pin	TO-220	TO-220 FullPAK	Super SO8	S308	Bare Die ( $R_{DS(on)}$ typ.)
4-7					IPB065N15N3 G $R_{DS(on)}=6.5m\Omega$					IPC302N15N3
7-12			IPI075N15N3 G $R_{DS(on)}=7.5m\Omega$	IPB072N15N3 G $R_{DS(on)}=7.2m\Omega$		IPP075N15N3 G $R_{DS(on)}=7.5m\Omega$	IPA075N15N3 G $R_{DS(on)}=6.5m\Omega$			
			IPI111N15N3 G $R_{DS(on)}=11.1m\Omega$	IPB108N15N3 G $R_{DS(on)}=10.8m\Omega$		IPP111N15N3 G $R_{DS(on)}=11.1m\Omega$	IPA105N15N3 G $R_{DS(on)}=10.5m\Omega$			
16-30	IPD200N15N3 G $R_{DS(on)}=20.0m\Omega$	BSB165N15N3 G $R_{DS(on)}=16.5m\Omega$	IPI200N15N3 G $R_{DS(on)}=20.0m\Omega$	IPB200N15N3 G $R_{DS(on)}=20.0m\Omega$		IPP200N15N3 G $R_{DS(on)}=20.0m\Omega$		BSC190N15NS3 G $R_{DS(on)}=19.0m\Omega$		
		BSB280N15N3 G $R_{DS(on)}=28.0m\Omega$								
30-60								BSC360N15NS3 G $R_{DS(on)}=36.0m\Omega$		
			IPI530N15N3 G $R_{DS(on)}=53.0m\Omega$	IPB530N15N3 G $R_{DS(on)}=53.0m\Omega$		IPP530N15N3 G $R_{DS(on)}=53.0m\Omega$		BSC520N15NS3 G $R_{DS(on)}=52.0m\Omega$	BSZ520N15NS3 G $R_{DS(on)}=52.0m\Omega$	
80-90	IPD530N15N3 G $R_{DS(on)}=53.0m\Omega$								BSZ900N15NS3 G $R_{DS(on)}=90.0m\Omega$	

All OptiMOS™ products are halogen free.

## OptiMOS™ 200V



$R_{DS(on)}$ @ $V_{GS}=10V$ [mΩ]	TO-252 DPAK	TO-262	TO-263 D <sup>2</sup> PAK	TO-263 7 Pin	TO-220	TO-220 FullPAK	Super SO8	S308	Bare Die ( $R_{DS(on)}$ typ.)
									IPC302N20N3
10-20		IPI110N20N3 G $R_{DS(on)}=11.0m\Omega$	IPB107N20N3 G $R_{DS(on)}=10.7m\Omega$		IPP110N20N3 G $R_{DS(on)}=11.0m\Omega$				
			IPB107N20NA ** $R_{DS(on)}=10.7m\Omega$		IPP110N20NA ** $R_{DS(on)}=11.0m\Omega$				
30-50	IPD320N20N3 G $R_{DS(on)}=32.0m\Omega$	IPI320N20N3 G $R_{DS(on)}=32.0m\Omega$	IPB320N20N3 G $R_{DS(on)}=32.0m\Omega$		IPP320N20N3 G $R_{DS(on)}=32.0m\Omega$		BSC320N20NS3 G $R_{DS(on)}=32.0m\Omega$		
80-100							BSC900N20NS3 G $R_{DS(on)}=90.0m\Omega$	BSZ900N20NS3 G $R_{DS(on)}=90.0m\Omega$	
100-200							BSC12DN20NS3 G $R_{DS(on)}=125.0m\Omega$	BSZ12DN20NS3 G $R_{DS(on)}=125.0m\Omega$	
200-300							BSC22DN20NS3 G $R_{DS(on)}=225.0m\Omega$	BSZ22DN20NS3 G $R_{DS(on)}=225.0m\Omega$	

## OptiMOS™ 250V



$R_{DS(on)}$ @ $V_{GS}=10V$ [mΩ]	TO-252 DPAK	TO-262	TO-263 D <sup>2</sup> PAK	TO-263 7 Pin	TO-220	TO-220 FullPAK	Super SO8	S308	Bare Die ( $R_{DS(on)}$ typ.)
10-20									IPC302N25N3 IPC302N25N3A **
20-30		IPI200N25N3 G $R_{DS(on)}=20.0m\Omega$	IPB200N25N3 G $R_{DS(on)}=20.0m\Omega$		IPP200N25N3 G $R_{DS(on)}=20.0m\Omega$				
60-70	IPD600N25N3 G $R_{DS(on)}=60.0m\Omega$	IPI600N25N3 G $R_{DS(on)}=60.0m\Omega$	IPB600N25N3 G $R_{DS(on)}=60.0m\Omega$		IPP600N25N3 G $R_{DS(on)}=60.0m\Omega$		BSC600N25NS3 G $R_{DS(on)}=60.0m\Omega$		
100-200							BSC16DN25NS3 G $R_{DS(on)}=165.0m\Omega$	BSZ16DN25NS3 G $R_{DS(on)}=165.0m\Omega$	
400-500								BSZ42DN25NS3 G $R_{DS(on)}=425.0m\Omega$	

\* in development

\*\* part qualified for Automotive

All OptiMOS™ products are halogen free.

# Small Signal



	Voltage	SOT-223	TSOP6	SOT-89	SC-59	SOT-23	SOT-323	SOT-363	Bare Die ( $R_{DS(on)}$ typ.)	
P-Channel MOSFETs	- 250	BSP317P 4.0Ω, -0.43A, LL								
		BSP92P 12.0Ω, -0.26A, LL		BSS192P 12.0Ω, -0.19A, LL	BSR92P 11.0Ω, -0.14A, LL					
	- 100	BSP321P 900.0mΩ, -0.98A, NL								
		BSP322P 800.0mΩ, -1.0A, LL								
		BSP316P 1.8Ω, -0.68A, LL				BSR316P 1.8Ω, -0.36A, LL				
	- 60	BSP613P 130.0mΩ, 2.9A, NL					BSS83P 2.0Ω, -0.33A, LL		SISC6,24P06	
		BSP170P 300.0mΩ, -1.9A, NL					BSS84P 8.0Ω, -0.17A, LL	BSS84PW 8.0Ω, -0.15, LL		
		BSP171P 300.0mΩ, -1.9A, LL								
		BSP315P 800.0mΩ, -1.17A, LL				BSR315P 800.0mΩ, -0.62A, LL				
	- 30			BSL303SPE * ~30.0mΩ, ~-6.6A, LL			BSR303PE * ~30.0mΩ, ~-3.3A, LL			
		BSP304PE * ~40.0mΩ, ~-5.5A, LL	BSL305SPE * ~50.0mΩ, ~-5.3A, LL			BSR305PE * ~50.0mΩ, ~-2.7A, LL				
		BSP306PE * ~60.0mΩ, ~-4.5A, LL	BSL307SP 43.0mΩ, -5.5A, LL				BSS308PE 80.0mΩ, -2.1A, LL, ESD			
			BSL308PE 80.0mΩ, -2.1A, LL, dual, ESD				BSS314PE 140.0mΩ, -1.5A, LL, ESD			
			BSL314PE 140.0mΩ, -1.5A, LL, ESD, dual				BSS315P 150.0mΩ, -1.5A, LL		BSD314SPE 140.0mΩ, -1.5A, LL, ESD	
			BSL315P 150.0mΩ, -1.5A, LL, dual					BSS356PWE * ~560.0mΩ, ~-0.73A, LL	BSD356PE * ~560.0mΩ, ~-0.73A, LL	
	- 20		BSL207SP 41.0mΩ, -6A, SLL					BSS209PW 550.0mΩ, -0.58A, SLL	BSV236SP 175.0mΩ, -1.5A, SLL	SISC01,18P02S SISC1.36P02Q
			BSL211SP 67.0mΩ, -4.7A, SLL					BSS223PW 1.2Ω, -0.39A, SLL	BSD223P 1.2Ω, -0.39A, SLL, dual	
			BSL215P 150.0mΩ, -1.5A, SLL, dual				BSS215P 150.0mΩ, -1.5A, SLL			

Low Voltage

All OptiMOS™ products are halogen free.

## Small Signal



	Voltage	SOT-223	TSOP6	SOT-89	SC-59	SOT-23	SOT-323	SOT-363
Complementary	-20 / 20		BSL215C N: 140.0mΩ, 1.5A, SLL P: 150.0mΩ, -1.5A, SLL					BSD235C N: 0.35Ω, 0.95A, SLL P: 1.2Ω, -0.53A, SLL
	-30 / 30		BSL316C N: 160.0mΩ, 1.4A, LL P: 150.0mΩ, -1.5A, LL					
				BSL308C N:57.0mΩ, A, LL P:80.0mΩ, A, LL,				

\* in development  
All OptiMOS™ products are halogen free.

# Small Signal

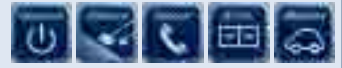

	Voltage	SOT-223	TSOP6	SOT-89	SC-59	SOT-23	SOT-323	SOT-363	Bare Die ( $R_{DS(on)}$ typ.)
N-Channel MOSFETs	20		BSL802SN 22.0mΩ, 7.5A, ULL		BSR802N 23.0mΩ, 3.7A, ULL				
			BSL202SN 22.0mΩ, 7.5A, SLL		BSR202N 21.0mΩ, 3.8A, SLL				
			BSL806N 57.0mΩ, 2.3A, ULL,dual			BSS806N 57.0mΩ, 2.3A, ULL		BSD816SN 160.0mΩ, 1.4A, ULL	
			BSL205N 50.0mΩ, 2.5A, SLL, dual			BSS205N 50.0mΩ, 2.5A, SLL		BSD214SN 140.0mΩ, 1.5A, SLL	
			BSL207N 70.0mΩ, 2.1A, SLL, dual				BSS816NW 160.0mΩ, 1.4A, ULL	BSD840N 400.0mΩ, 0.88A, ULL, dual	
			BSL214N 140.0mΩ, 1.5A, SLL, dual			BSS214N 140.0mΩ, 1.5A, SLL	BSS214NW 140.0mΩ, 1.5A, SLL	BSD235N 350.0mΩ, 0.95A, SLL, dual	
	30		BSL302SN 25.0mΩ, 7.1A, LL		BSR302N 23.0mΩ, 3.7A, LL	BSS306N 57.0mΩ, 2.3A, LL			
			BSL306N 57.0mΩ, 2.3A, LL, dual			BSS316N 160.0mΩ, 1.4A, LL		BSD316SN 160.0mΩ, 1.4A, LL	
	55					BSS670S2L 650.0mΩ, 0.54A, LL			
	60	BSP318S 90.0mΩ, 2.6A, LL	BSL606N * 60.0mΩ, 4.5A, LL	BSS606N 60.0mΩ, 2.3A, LL	BSR606N * 60.0mΩ, 2.3A, LL	BSS138N 3.5Ω, 0.23A, LL	BSS138W 3.5Ω, 0.28A, LL		SISC0,3N06D SISC02,3N06E1,0
		BSP320S 120.0mΩ, 2.9A, NL				BSS7728N 5.0Ω, 0.2A, LL			SISC2,62SN06L
		BSP295 300.0mΩ, 1.8A, LL				SN7002N 5.0Ω, 0.2A, LL	SN7002W 5.0Ω, 0.23A, LL		
						2N7002 3.0Ω, 0.3A, LL		2N7002DW 30.0, 0.3A, LL, dual	
						BSS159N 8.0Ω, 0.13A, depl.			
	75	BSP716 * ~160.0mΩ, A, LL							

Low Voltage

All OptiMOS™ products are halogen free.

## Small Signal



	Voltage	SOT-223	TSOP6	SOT-89	SC-59	SOT-23	SOT-323	Bare Die ( $R_{DS(on)}$ typ.)
N-Channel MOSFETs	100	BSP373 300.0mΩ, 1.7A, NL				BSS169 12.0Ω, 0.09A, depl.		SISCO,50N10D
		BSP372 310.0mΩ, 1.7A, LL				BSS119 6.0Ω, 0.17A, LL VGSth 1.8V to 2.3V		
		BSP296 700.0mΩ, 1.1A, LL						
	200	BSP123 6.0Ω, 0.37A, LL				BSS123 6.0Ω, 0.17A, LL VGSth 0.8V to 1.8V		
		BSP297 1.8Ω, 0.66A, LL						SISC2,9N20D
		BSP149 3.5Ω, 0.14 A, depl.						
	240	BSP88 6.0Ω, 0.35A, 2.8V rated		BSS87 6.0Ω, 0.26A, LL		BSS131 14.0Ω, 0.1A, LL		SISCO,97N24D
		BSP89 6.0Ω, 0.35A, LL						
		BSP129 6.0Ω, 0.05A, depl.						
	250					BSS139 30.0Ω, 0.03A, depl.		SISCO,97N25E1,4 SISCO,64N25D
	400	BSP298 3.0Ω, 0.5A, NL						
		BSP324 25.0Ω, 0.17A, LL						
	500	BSP299 4.0Ω, 0.4A, NL						
	600	BSP125 45.0Ω, 0.12A, LL		BSS225 45.0Ω, 0.09A, LL		BSS127 500.0Ω, 0.023A, LL		SISC1,40N60D SISCO,52N60E
BSP135 6.00Ω, 0.02A, depl.					BSS126 700.0Ω, 0.007A, depl.			
800	BSP300 20.0Ω, 0.19A, NL							

to be used from  $V_{GS}$

NL = Normal Level	10V
LL = Logic Level	4.5V
SLL = Super Logic Level	2.5V
ULL = Ultra Logic Level	1.8V

\* in development

\*\* 5-leg

All OptiMOST™ products are halogen free.

## P-Channel MOSFETs



$R_{DS(on)}$ @ $V_{GS}=10V$ [m $\Omega$ ]		TO-220	TO-252 (DPAK)	TO-263 (D <sup>2</sup> PAK)	S08	SuperS08	S308	CanPAK
- 20V	7		IPD042P03L3 G IPD068P03L3 G		BSO201SP			
	21				BSO203SP BSO203P (dual)			
	30				BSO204P (dual)			
	45				BSO207P (dual)			
	67				BSO211P (dual)			
- 30V	3					BSC030P03NS3 G		BSB027P03LX3 G * BSB028P03NS3 G * BSB029P03NX3 G *
	4,2		IPD042P03L3 G					
	5-7		SPD50P03L G ** IPD068P03L3 G		BSO053P03NS3E G *	BSC060P03NS3E G		
	~8				BSO080P03NS3 G BSO080P03NS3E G BSO080P03S BSO301SP	BSC080P03LS G BSC084P03NS3 G BSC084P03NS3E G	BSZ086P03NS3 G BSZ086P03NS3E G	
	12						BSZ120P03NS3 G	
	13				BSO120P03S	BSC130P03LS G		
	18						BSZ180P03NS3 G	
	20				BSO200P03S BSO303SP	BSC200P03LS G		
	21				BSO303P (dual)			
1,2 $\Omega$								
- 60V	23	SPP80P06P		SPB80P06 G				
	75		SPD30P06P G					
	130	SPP18P06P	SPD18P06P G	SPB18P06P G	BSO613SPV G			
	250		SPD09P06PL G					
	300	SPP08P06P	SPD08P06P G	SPB08P06P G				
- 100V	210	SPP15P10PL G	SPD15P10PL G					
	240	SPP15P10P G	SPD15P10P G					
	850		SPD04P10PL G					
	1 $\Omega$		SPD04P10P G					

All OptiMOS™ products are halogen free.

# Naming System

## OptiMOS™

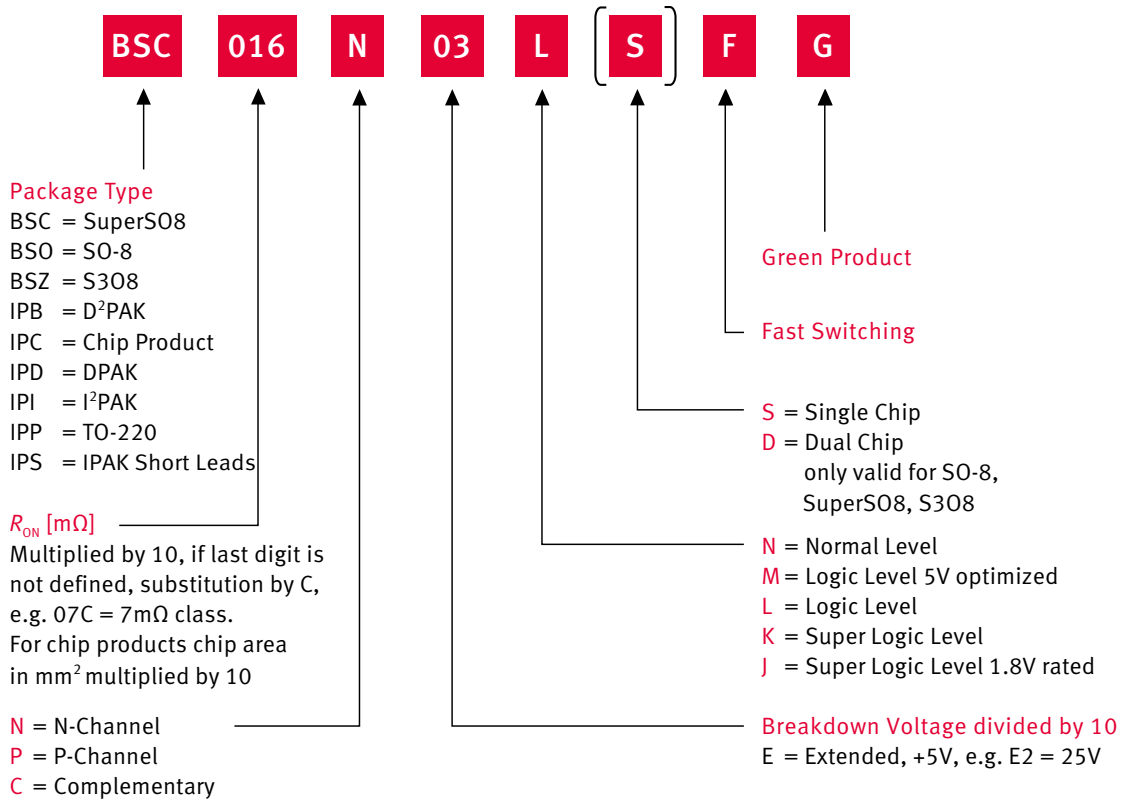

# Naming System

## New OptiMOS™

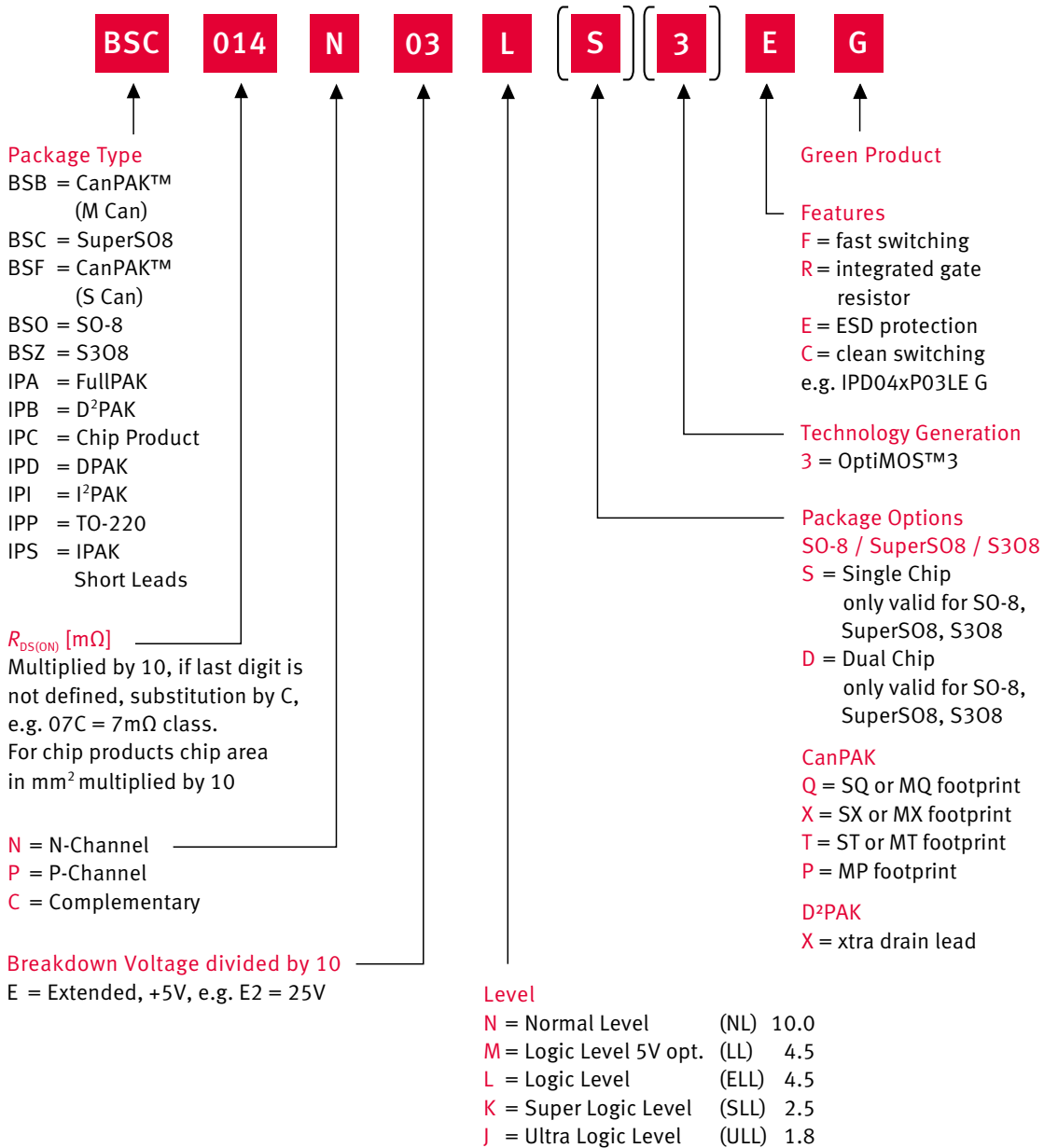

## OptiMOS™ 30V

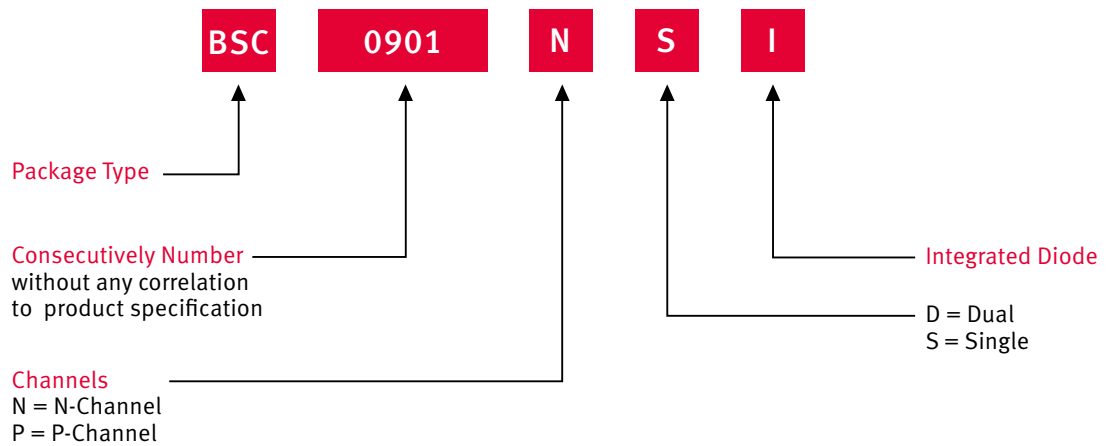

## Small Signal

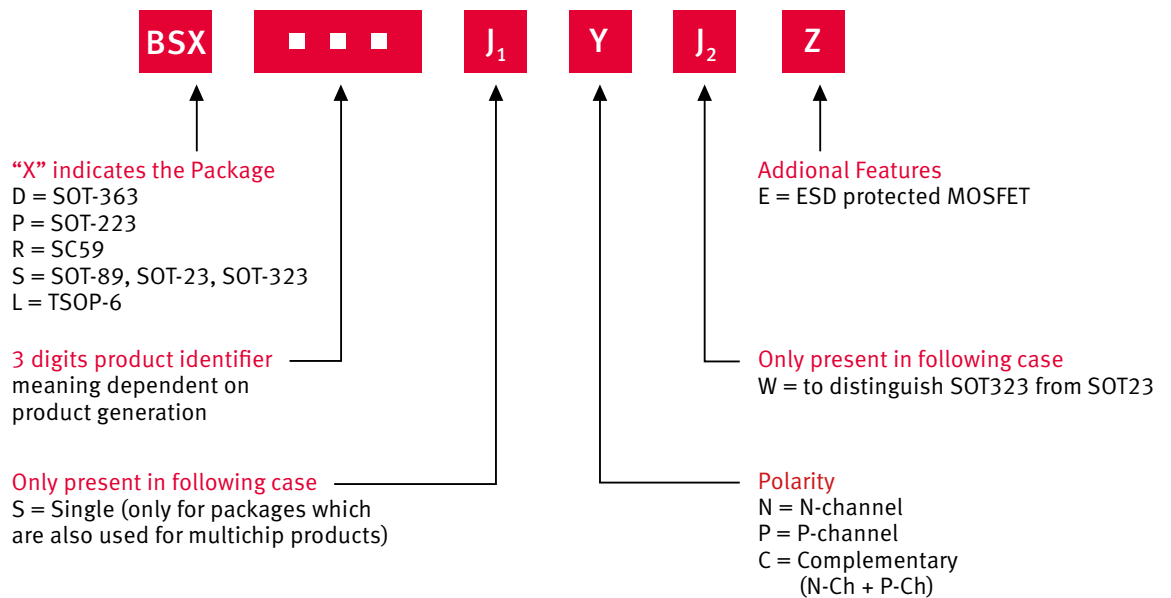

# CoolMOS™

The revolutionary CoolMOS™ power family sets new standards in the field of Energy Efficiency. As technology leader in high voltage MOSFETs, CoolMOS™ offers a significant reduction of conduction and switching losses and enables high power density and efficiency for superior power conversion systems. Especially the latest, state-of-the-art generation of high voltage power MOSFETs made it possible that AC/DC power supplies are more efficient, more compact, lighter and cooler than ever before. This success was achieved by offering the lowest on-state resistance per package outline, the fastest switching speed and the lowest gate driver requirements of high voltage MOSFETs commercially available.

## Features

- Offers a significant reduction of conduction and switching losses
- Enables high power density and efficiency for superior power conversion systems
- Best-in-class price/performance ratio

## Benefits

- Easy control of switching behavior
- Outstanding reliability with proven CoolMOS™ quality combined with high body diode ruggedness
- More efficient, more compact, lighter and cooler

## CoolMOS™ technology

### On state: Reduction of resistance of epitaxial layer by high doped n-columns

- Higher doping level in n-type drift region results in lower  $R_{DS(on)}$

### Blocking state: Compensation of additional charge by adjacent p-columns

- Half of active chip area is covered by p-columns
- During blocking state the p-column compensates the charge of the adjacent n-column resulting in high breakdown voltage at an area specific on-resistance below the silicon limit

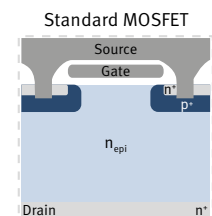
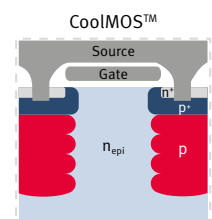

## Main Applications

- Adapter
- PC Silverbox
- Server
- Telecom
- Solar
- UPS
- HID lighting

## CoolMOS™ - a history

Since the development of the innovative CoolMOS™ technology we help applications to meet the standby power and Energy Efficiency regulations. CoolMOS™ is used for example in lighting applications where Energy Efficiency is more than ever a pre-condition as well as in solar inverters of market leaders.

### S5 series:

- first series of CoolMOS™, market entry in 1998
- slow switching, close to converter MOSFET,  $V_{th}$  4.5 V,  $g_{fs}$  low,  $R_g$  high
- design-in in high power SMPS only

### C3 series:

- third series of CoolMOS™, market entry in 2001
- the "working horse" of the portfolio, fast switching, symmetrical rise/fall time @10 V  $V_{gs}$ ,  $V_{th}$  3 V,  $g_{fs}$  high,  $R_g$  very low
- design-in into all CoolMOS™ segments

### CFD series:

- fourth series of CoolMOS™, market entry in 2004
- fast body diode,  $Q_{rr}$  1/10<sup>th</sup> of C3 series,  $V_{th}$  4 V,  $g_{fs}$  high,  $R_g$  low
- specific for phase-shift ZVS and DC/AC power applications

### CP series:

- fifth series of CoolMOS™, market entry in 2005
- ultra low  $R_{DS(on)}$ , ultra low gate charge, very fast switching
- $V_{th}$  3 V,  $g_{fs}$  very high, internal  $R_g$  very low

### C6 / E6 series:

- sixth series of CoolMOS™, market entry 2009
- is the successor of C3

### CFD2 series:

- Seventh series of CoolMOS™, Market entry 2011
- First 650V Super Junction device, with fast body diode
- Is the successor of CFD, suitable for resonant topologies

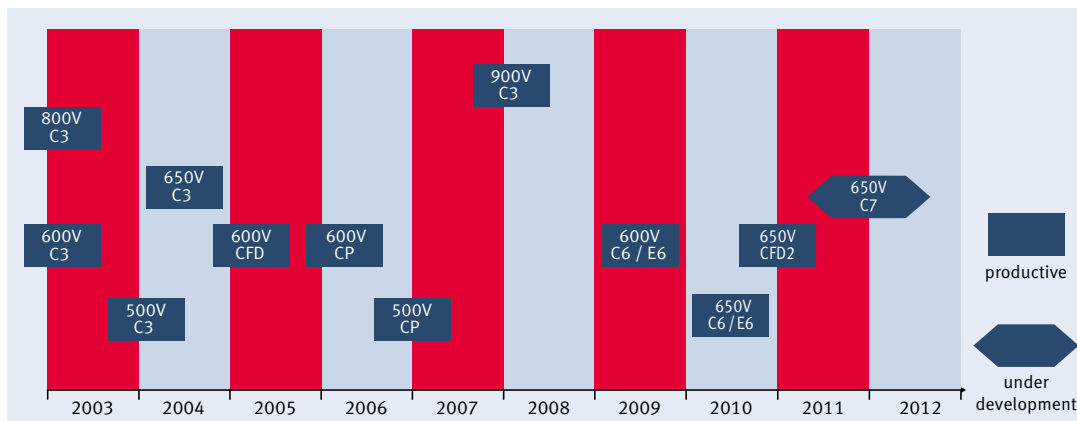

## 650V CoolMOS™ CFD2

With the new 650V CoolMOS™ CFD2 Infineon launches its second generation of its market leading high voltage CoolMOS™ MOSFETs with integrated fast body diode. The new CFD2 devices are the successor of 600V CFD with improved Energy Efficiency. The softer commutation behavior and therefore better EMI behavior gives this product a clear advantage in comparison with competitor parts.

CFD2 is the first 650V MOSFET technology with integrated fast body diode on the market. The product portfolio provides all benefits of fast switching superjunction MOSFETs offering better light load efficiency, reduced gate charge, easy implementation and outstanding reliability. The new CFD2 technology offers lower prices compared to its predecessor 600V CFD and is the best choice for resonant switching applications.

	DPAK (TO-252)	D <sup>2</sup> PAK (TO-263)	TO-220FP (TO-220)	TO-220 (TO-220)	I <sup>2</sup> PAK (TO-262)	TO-247 (TO-247)
1K4*	IPD65R1K4CFD					
950*	IPD65R950CFD					
660	IPD65R660CFD	IPB65R660CFD	IPA65R660CFD	IPP65R660CFD	IPI65R660CFD	IPW65R660CFD
420	IPD65R420CFD	IPB65R420CFD	IPA65R420CFD	IPP65R420CFD	IPI65R420CFD	IPW65R420CFD
310		IPB65R310CFD	IPA65R310CFD	IPP65R310CFD	IPI65R310CFD	IPW65R310CFD
190		IPB65R190CFD	IPA65R190CFD	IPP65R190CFD	IPI65R190CFD	IPW65R190CFD
150*		IPB65R150CFD	IPA65R150CFD	IPP65R150CFD	IPI65R150CFD	IPW65R150CFD
110		IPB65R110CFD	IPA65R110CFD	IPP65R110CFD	IPI65R110CFD	IPW65R110CFD
80						IPW65R080CFD
41						IPW65R041CFD

\* in development

**Applications**

- Telecom
- Server
- Battery Charging
- Solar
- HID lamp ballast
- LED lighting

**Features**

- First 650V technology with integrated fast body diode on the market
- Limited voltage overshoot during hard commutation
- Significant  $Q_g$  reduction compared to C3 based CFD technology
- Tighter  $R_{DS(on)}$  max to  $R_{DS(on)}$  typ window
- Easy to design in
- Lower price compared to 600V CFD technology

**Topologies**

- ZVS phase shifted full bridge
- LLC topologies
- AC / DC bridge
- 3-level inverter

**Benefits**

- Low switching losses due to low  $Q_{rr}$  at repetitive commutation on body diode
- Self limiting di/dt and dv/dt
- Low  $Q_{oss}$
- Reduced turn on and turn off delay times
- Outstanding CoolMOS™ quality

CFD vs. CFD2 efficiency comparison in a 12 V Server SMPS used Topologie ZVS FB @ 100 kHz

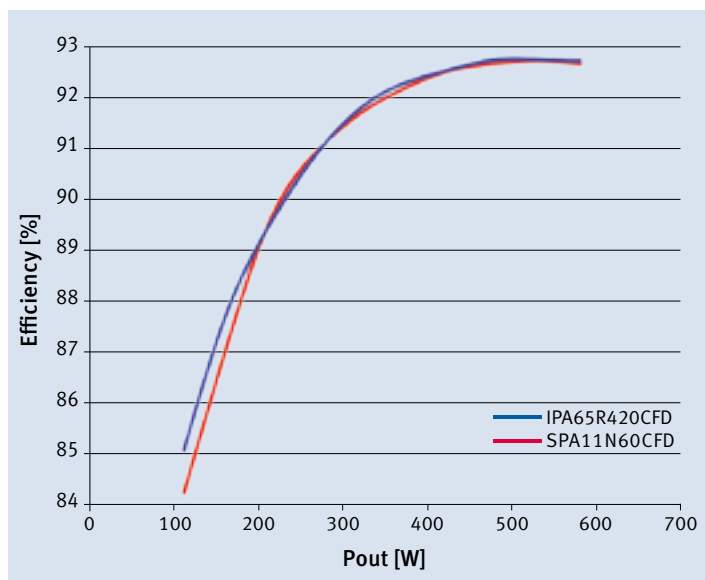

## CoolMOST™ C3 500V



$I_D$ [A]	$R_{DS(on)}$ [mΩ]	$Q_g$ [nC]	TO-251 IPAK	TO-251 IPAK SL short leads	TO-252 DPAK	TO-262 I <sup>2</sup> PAK Halogen-Free	TO-263 D <sup>2</sup> PAK Halogen-Free	TO-220 Halogen-Free	TO-220 FullPAK Halogen-Free	TO-247
1.8	3000	9			SPD02N50C3					
3.2	1400	15			SPD03N50C3					
4.5	950	22			SPD04N50C3		SPB04N50C3	SPP04N50C3	SPA04N50C3	
7.6	600	32			SPD08N50C3	SPI08N50C3		SPP08N50C3	SPA08N50C3	
11.6	380	49				SPI12N50C3	SPB12N50C3	SPP12N50C3	SPA12N50C3	SPW12N50C3
16	280	66				SPI16N50C3	SPB16N50C3	SPP16N50C3	SPA16N50C3	SPW16N50C3
21	190	95				SPI21N50C3	SPB21N50C3	SPP21N50C3	SPA21N50C3	SPW21N50C3
32	110	170								SPW32N50C3
52	70	290								SPW52N50C3

## CoolMOST™ C3 600V



$I_D$ [A]	$R_{DS(on)}$ [mΩ]	$Q_g$ [nC]	TO-251 IPAK	TO-251 IPAK SL short leads	TO-252 DPAK	TO-262 I <sup>2</sup> PAK Halogen-Free	TO-263 D <sup>2</sup> PAK Halogen-Free	TO-220 Halogen-Free	TO-220 FullPAK Halogen-Free	TO-247
0.8	6000	3.9	SPU01N60C3	SPS01N60C3	SPD01N60C3					
1.8	3000	9.5	SPU02N60C3	SPS02N60C3	SPD02N60C3		SPB02N60C3	SPP02N60C3		
3.2	1400	13	SPU03N60C3	SPS03N60C3	SPD03N60C3		SPB03N60C3	SPP03N60C3		
4.5	950	19	SPU04N60C3	SPS04N60C3	SPD04N60C3		SPB04N60C3	SPP04N60C3	SPA04N60C3	
6.2	750	24			SPD06N60C3			SPP06N60C3	SPA06N60C3	
7.3	600	21	SPU07N60C3		SPD07N60C3	SPI07N60C3	SPB07N60C3	SPP07N60C3	SPA07N60C3	
11	380	45				SPI11N60C3	SPB11N60C3	SPP11N60C3	SPA11N60C3	SPW11N60C3
15	280	63				SPI15N60C3		SPP15N60C3	SPA15N60C3	SPW15N60C3
20.7	190	87				SPI20N60C3	SPB20N60C3	SPP20N60C3		SPW20N60C3
24.3	160	104.9						SPP24N60C3		SPW24N60C3
34.6	100	150								SPW35N60C3
47	70	252								SPW47N60C3

## CoolMOS™ C3 650V



$I_D$ [A]	$R_{DS(on)}$ [mΩ]	$Q_g$ [nC]	TO-251 IPAK	TO-251 IPAK SL short leads	TO-252 DPAK	TO-262 I <sup>2</sup> PAK	TO-263 D <sup>2</sup> PAK	TO-220	TO-220 FullPAK	TO-247
						Halogen-Free	Halogen-Free	Halogen-Free	Halogen-Free	
7.3	600	21				SPI07N65C3		SPP07N65C3	SPA07N65C3	
11	380	45				SPI11N65C3		SPP11N65C3	SPA11N65C3	
15	280	63				SPI15N65C3		SPP15N65C3	SPA15N65C3	
20.7	190	87				SPI20N65C3		SPP20N65C3	SPA20N65C3	
47	70	255								SPW45N65C3

## CoolMOS™ C3 800V



$I_D$ [A]	$R_{DS(on)}$ [mΩ]	$Q_g$ [nC]	TO-251 IPAK	TO-251 IPAK SL short leads	TO-252 DPAK	TO-262 I <sup>2</sup> PAK	TO-263 D <sup>2</sup> PAK	TO-220	TO-220 FullPAK	TO-247
						Halogen-Free	Halogen-Free	Halogen-Free	Halogen-Free	
2	2700	9			SPD02N80C3			SPP02N80C3	SPA02N80C3	
4	1300	20			SPD04N80C3			SPP04N80C3	SPA04N80C3	
6	900	27			SPD06N80C3			SPP06N80C3	SPA06N80C3	
8	650	40				SPI08N80C3		SPP08N80C3	SPA08N80C3	
11	450	50						SPP11N80C3	SPA11N80C3	SPW11N80C3
17	290	91					SPB17N80C3	SPP17N80C3	SPA17N80C3	SPW17N80C3
tbd	85	tbd								SPW55N80C3

## CoolMOS™ C3 900V



$I_D$ [A]	$R_{DS(on)}$ [mΩ]	$Q_g$ [nC]	TO-251 IPAK	TO-251 IPAK SL short leads	TO-252 DPAK	TO-262 I <sup>2</sup> PAK	TO-263 D <sup>2</sup> PAK	TO-220	TO-220 FullPAK	TO-247
						Halogen-Free	Halogen-Free	Halogen-Free	Halogen-Free	
5.1	1200	29			IPD90R1K2C3	IPI90R1K2C3		IPP90R1K2C3	IPA90R1K2C3	IPW90R1K2C3
5.7	1000	34				IPI90R1K0C3		IPP90R1K0C3	IPA90R1K0C3	IPW90R1K0C3
6.9	800	42				IPI90R800C3		IPP90R800C3	IPA90R800C3	IPW90R800C3
11	500	68				IPI90R500C3		IPP90R500C3	IPA90R500C3	IPW90R500C3
15	340	93				IPI90R340C3		IPP90R340C3	IPA90R340C3	IPW90R340C3
36	120	260								IPW90R120C3

## CoolMOST™ CP 500V



$I_D$ [A]	$R_{DS(on)}$ [mΩ]	$Q_g$ [nC]	TO-251 IPAK	TO-251 IPAK SL short leads	TO-252 DPAK	TO-262 I <sup>2</sup> PAK Halogen-Free	TO-263 D <sup>2</sup> PAK Halogen-Free	TO-220 Halogen-Free	TO-220 FullPAK Halogen-Free	TO-247
7.1	520	13		IPS50R520CP	IPD50R520CP			IPP50R520CP	IPA50R520CP	
9	399	17			IPD50R399CP	IPI50R399CP		IPP50R399CP	IPA50R399CP	IPW50R399CP
10	350	19				IPI50R350CP		IPP50R350CP	IPA50R350CP	IPW50R350CP
12	299	23				IPI50R299CP	IPB50R299CP	IPP50R299CP	IPA50R299CP	IPW50R299CP
13	250	27				IPI50R250CP	IPB50R250CP	IPP50R250CP	IPA50R250CP	IPW50R250CP
17	199	34				IPI50R199CP	IPB50R199CP	IPP50R199CP	IPA50R199CP	IPW50R199CP
23	140	48				IPI50R140CP	IPB50R140CP	IPP50R140CP	IPA50R140CP	IPW50R140CP

## CoolMOST™ CP 600V



$I_D$ [A]	$R_{DS(on)}$ [mΩ]	$Q_g$ [nC]	ThinPAK 8 x 8 Halogen-Free	TO-251 IPAK	TO-251 IPAK SL short leads	TO-252 DPAK	TO-262 I <sup>2</sup> PAK Halogen-Free	TO-263 D <sup>2</sup> PAK Halogen-Free	TO-220 Halogen-Free	TO-220 FullPAK Halogen-Free	TO-247
6.1	600	21				IPD60R600CP	IPI60R600CP	IPB60R600CP	IPP60R600CP	IPA60R600CP	
6.8	520	24				IPD60R520CP	IPI60R520CP	IPB60R520CP	IPP60R520CP	IPA60R520CP	
9	385	17	IPL60R385CP			IPD60R385CP	IPI60R385CP	IPB60R385CP	IPP60R385CP	IPA60R385CP	
11	299	22	IPL60R299CP				IPI60R299CP	IPB60R299CP	IPP60R299CP	IPA60R299CP	IPW60R299CP
12	250	26					IPI60R250CP	IPB60R250CP	IPP60R250CP	IPA60R250CP	IPW60R250CP
16	199	32	IPL60R199CP				IPI60R199CP	IPB60R199CP	IPP60R199CP	IPA60R199CP	IPW60R199CP
21	165	39					IPI60R165CP	IPB60R165CP	IPP60R165CP	IPA60R165CP	IPW60R165CP
25	125	53					IPI60R125CP	IPB60R125CP	IPP60R125CP	IPA60R125CP	IPW60R125CP
31	99	60					IPI60R099CP	IPB60R099CP	IPP60R099CP		IPW60R099CP
39	75	86									IPW60R075CP
60	45	150									IPW60R045CP

## CoolMOS™ C6 600V



$I_D$ [A]	$R_{DS(on)}$ [mΩ]	$Q_g$ [nC]	TO-251 IPAK	TO-251 IPAK SL short leads	TO-252 DPAK	TO-262 I <sup>2</sup> PAK Halogen-Free	TO-263 D <sup>2</sup> PAK Halogen-Free	TO-220 Halogen-Free	TO-220 FullPAK Halogen-Free	TO-247
4	3300	4.7			IPD60R3K3C6					
6	2000	6.7			IPD60R2K0C6					
8	1400	9.4			IPD60R1K4C6					
4.4	950	13			IPD60R950C6		IPB60R950C6	IPP60R950C6	IPA60R950C6	
7.3	600	20.5			IPD60R600C6		IPB60R600C6	IPP60R600C6	IPA60R600C6	
8.1	520	23.4			IPD60R520C6			IPP60R520C6	IPA60R520C6	
10.6	380	32			IPD60R380C6	IPI60R380C6	IPB60R380C6	IPP60R380C6	IPA60R380C6	
13.8	280	43				IPI60R280C6	IPB60R280C6	IPP60R280C6	IPA60R280C6	IPW60R280C6
20.2	190	58				IPI60R190C6	IPB60R190C6	IPP60R190C6	IPA60R190C6	IPW60R190C6
23.8	160	75					IPB60R160C6	IPP60R160C6	IPA60R160C6	IPW60R160C6
30	125	96					IPB60R125C6	IPP60R125C6	IPA60R125C6	IPW60R125C6
38	99	119					IPB60R099C6	IPP60R099C6	IPA60R099C6	IPW60R099C6
57.7	74	131						IPP60R074C6		
53.5	70	170								IPW60R070C6
77.5	41	290								IPW60R041C6

## CoolMOS™ E6 600V



$I_D$ [A]	$R_{DS(on)}$ [mΩ]	$Q_g$ [nC]	TO-251 IPAK	TO-251 IPAK SL short leads	TO-252 DPAK	TO-262 I <sup>2</sup> PAK Halogen-Free	TO-263 D <sup>2</sup> PAK Halogen-Free	TO-220 Halogen-Free	TO-220 FullPAK Halogen-Free	TO-247
5.7	750	17.2			IPD60R750E6			IPP60R750E6	IPA60R750E6	
7.3	600	20.5			IPD60R600E6			IPP60R600E6	IPA60R600E6	
8.1	520	23.5						IPP60R520E6	IPA60R520E6	
9.2	450	28			IPD60R450E6			IPP60R450E6	IPA60R450E6	
10.6	380	32						IPP60R380E6	IPA60R380E6	
13.8	280	43						IPP60R280E6	IPA60R280E6	IPW60R280E6
20.2	190	63						IPP60R190E6	IPA60R190E6	IPW60R190E6

## CoolMOST™ C6 650V



$I_D$ [A]	$R_{DS(on)}$ [mΩ]	$Q_g$ [nC]	TO-251 IPAK	TO-251 IPAK SL short leads	TO-252 DPAK	TO-262 I²PAK	TO-263 D²PAK	TO-220	TO-220 FullPAK	TO-247
						Halogen-Free	Halogen-Free	Halogen-Free	Halogen-Free	
7.3	600	23			IPD65R600C6	IPI65R600C6	IPB65R600C6	IPP65R600C6	IPA65R600C6	
10.6	380	39			IPD65R380C6	IPI65R380C6	IPB65R380C6	IPP65R380C6	IPA65R380C6	
13.8	280	45				IPI65R280C6	IPB65R280C6	IPP65R280C6	IPA65R280C6	IPW65R280C6
20.7	190	87				IPI65R190C6	IPB65R190C6	IPP65R190C6	IPA65R190C6	IPW65R190C6
tbd	99	tbd						IPP65R099C6	IPA65R099C6	IPW65R099C6
47	70	255								IPW65R070C6
tbd	37	tbd								IPW65R037C6

## CoolMOST™ E6 650V



$I_D$ [A]	$R_{DS(on)}$ [mΩ]	$Q_g$ [nC]	ThinPAK 8 x 8	TO-251 IPAK	TO-251 IPAK SL short leads	TO-252 DPAK	TO-262 I²PAK	TO-263 D²PAK	TO-220	TO-220 FullPAK	TO-247
			Halogen-Free				Halogen-Free	Halogen-Free	Halogen-Free	Halogen-Free	
7.3	600	23	IPL65R600E6*			IPD65R600E6			IPP65R600E6	IPA65R600E6	
10.6	380	39	IPL65R380E6*			IPD65R380E6			IPP65R380E6	IPA65R380E6	
13.8	280	45	IPL65R280E6*						IPP65R280E6	IPA65R280E6	IPW65R280E6
tbd	190	tbd	IPL65R190E6*						IPP65R190E6*	IPA65R190E6*	IPW65R190E6*

\* in development

## CoolMOS™ CFD 600V



$I_D$ [A]	$R_{DS(on)}$ [mΩ]	$Q_g$ [nC]	TO-251 IPAK	TO-251 IPAK SL short leads	TO-252 DPAK	TO-262 I <sup>2</sup> PAK Halogen-Free	TO-263 D <sup>2</sup> PAK Halogen-Free	TO-220 Halogen-Free	TO-220 FullPAK Halogen-Free	TO-247
6.6	700	35						SPP07N60CFD	SPA07N60CFD	SPW07N60CFD
11	440	48				SPI11N60CFD		SPP11N60CFD	SPA11N60CFD	SPW11N60CFD
13.4	330	63				SPI15N60CFD		SPP15N60CFD	SPA15N60CFD	SPW15N60CFD
20.7	220	95				SPI20N60CFD		SPP20N60CFD	SPA20N60CFD	SPW20N60CFD
21.7	185	110						SPP24N60CFD		SPW24N60CFD
34.1	115	163								SPW35N60CFD
46	80	248								SPW47N60CFD

## CoolMOS™ CFD2 650V



$I_D$ [A]	$R_{DS(on)}$ [mΩ]	$Q_g$ [nC]	TO-251 IPAK	TO-251 IPAK SL short leads	TO-252 DPAK	TO-262 I <sup>2</sup> PAK Halogen-Free	TO-263 D <sup>2</sup> PAK Halogen-Free	TO-220 Halogen-Free	TO-220 FullPAK Halogen-Free	TO-247
tbd	1400	tbd			IPD65R1K4CFD*					
tbd	950	tbd			IPD65R950CFD*					
6.0	660	20			IPD65R660CFD	IPI65R660CFD	IPB65R660CFD	IPP65R660CFD	IPA65R660CFD	IPW65R660CFD
8.7	420	32			IPD65R420CFD	IPI65R420CFD	IPB65R420CFD	IPP65R420CFD	IPA65R420CFD	IPW65R420CFD
11.4	310	41				IPI65R310CFD	IPB65R310CFD	IPP65R310CFD	IPA65R310CFD	IPW65R310CFD
17.5	190	68				IPI65R190CFD	IPB65R190CFD	IPP65R190CFD	IPA65R190CFD	IPW65R190CFD
tbd	150	tbd				IPI65R150CFD*	IPB65R150CFD*	IPP65R150CFD*	IPA65R150CFD*	IPW65R150CFD*
31.2	110	118				IPI65R110CFD	IPB65R110CFD	IPP65R110CFD	IPA65R110CFD	IPW65R110CFD
43.3	80	162								IPW65R080CFD
68	41	300								IPW65R041CFD

# Naming System

## Power MOSFETs (naming system till 2005)

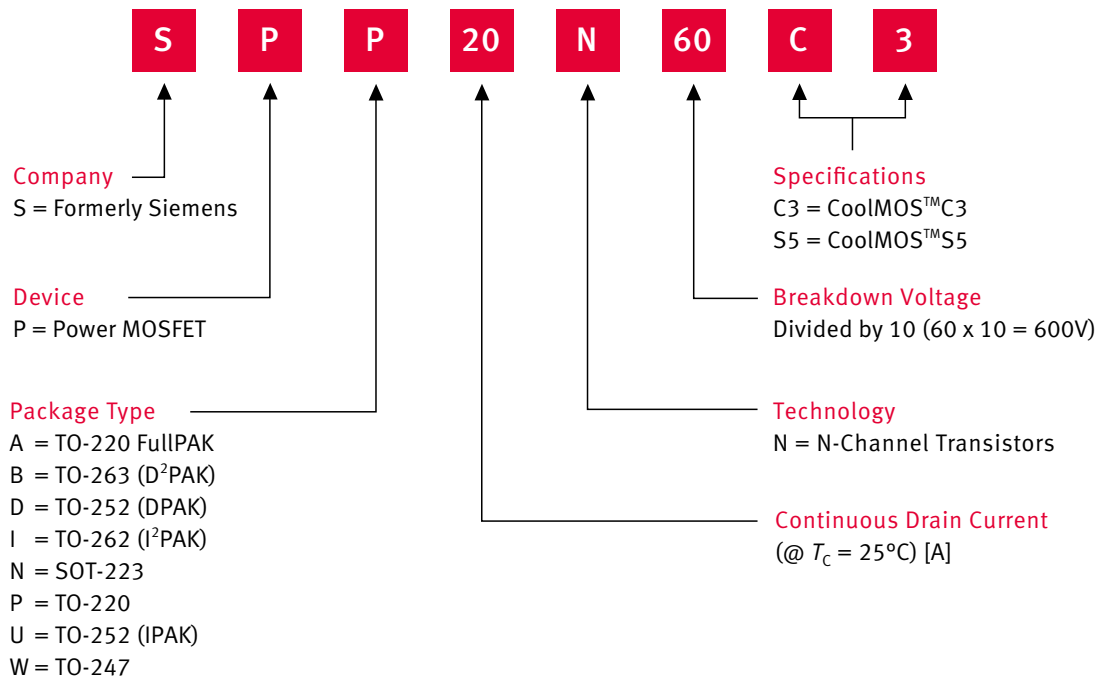

## Power MOSFETs (naming system from 2005 onwards)

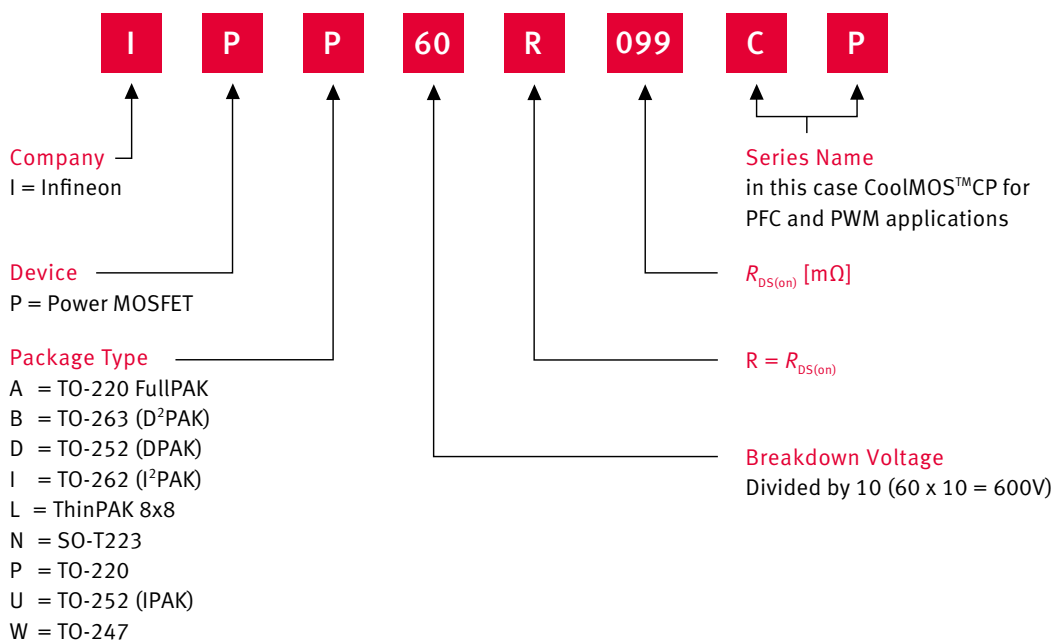



# Silicon Carbide Schottky Diodes

Silicon Carbide (SiC) is a revolutionary material for power semiconductors; its physical properties outperform Silicon devices by far. Infineon offers SiC Schottky diodes in 600V and 1200V.

## Features

- Benchmark switching behavior
- No reverse recovery
- No temperature influence on the switching behavior
- Standard operating temperature -55° to 175°C

SiC power devices enable increased efficiency, reduced solution size, higher switching frequency and produce significant less electromagnetic interference (EMI) in a variety of target applications

## Applications

- Power factor correction
- Solar and UPS inverters
- Motor drives
- Output rectification

## The latest SiC generation: ThinQ!™ 3G

The latest generation of Infineon SiC Schottky diodes features the industry's lowest device capacitance for any given current rating, which further enhances overall system efficiency, especially at higher switching frequencies and under low load conditions. Additionally, Infineon provides the industry's broadest SiC Schottky diode portfolio which not only includes the TO-220 package (real 2pin version) but also the DPAK package for high power density surface mount designs.

## Features

- Lowest switching losses due to lowest  $Q_c$  ( $Q_{rr}$ ) for any current rating in the market
- Fully surge-current stable, high reliability and ruggedness
- Best price/performance ratio in SiC

## Benefits

- System efficiency improvements at light & medium load
- Enabling higher frequency designs and increased power density solutions
- Lower system costs due to reduced cooling requirements
- Broadest range of current ratings and lower costs/Amp. for cost-effective performance improvements

## SiC Schottky diodes thinQ!™

### Second Generation now available in TO-220 FullPAK

High efficiency and thermal performance combine in a full isolated solution. The new FullPAK solution combines the high electrical performance standards of Infineon second generation SiC Schottky diodes and the advantages of a full isolated package, without significant impact on thermal behavior compared to standard TO-220 solutions. The patented diffusion soldering technique enables to consistently reduce the “chip-to-leadframe” thermal resistance and positions Infineon FullPAK products as best-in-class performance. Additionally, we offer the industry’s broadest portfolio in this package with current ratings up to 6A.

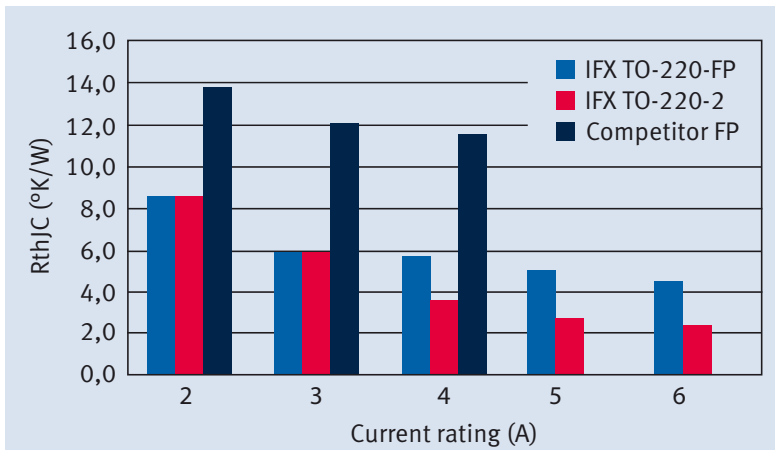

The graph shows the same junction-case thermal resistance for Infineon products at 2A and 3A, and slightly higher values for the other current ratings. This small difference is in general compensated on the final design assembly due to the need of an isolation foil for the standard TO-220 package. A clear advance on competition (only products up to 3A available) is possible thanks to Infineon patented diffusion soldering.

## 600V Silicon Carbide High Voltage Schottky Diodes thinQ!™ 2G



$I_F$ [A]	$Q_C$ [nC]	$I_{FSM}$ [A]	TO-252 DPAK	TO-263 D <sup>2</sup> PAK	TO-220 Real 2Pin	TO-220 FullPAK
2	3.2	11.5				IDV02S60C
3	5	16				IDV03S60C
4	8	32	IDD04S60C		IDH04S60C	IDV04S60C
5	12	42			IDH05S60C	IDV05S60C
6	15	49		IDB06S60C	IDH06S60C	IDV06S60C
8	19	59			IDH08S60C	
10	24	84		IDB10S60C	IDH10S60C	
12	30	98			IDH12S60C	
16	38	118			IDH16S60C	

### 600V Silicon Carbide High Voltage Schottky Diodes thinQ!<sup>TM</sup> 3G



$I_F$ [A]	$Q_C$ [nC]	$I_{FSM}$ [A]	TO-252 DPAK	TO-263 D <sup>2</sup> PAK	TO-220 Real 2Pin	TO-220 FullPAK
3	3.2	11.5	IDD03SG60C		IDH03SG60C	
4	4.5	18	IDD04SG60C		IDH04SG60C	
5	6	26	IDD05SG60C		IDH05SG60C	
6	8	32	IDD06SG60C		IDH06SG60C	
8	12	42	IDD08SG60C		IDH08SG60C	
9	15	49	IDD09SG60C		IDH09SG60C	
10	16	51	IDD10SG60C		IDH10SG60C	
12	19	59	IDD12SG60C		IDH12SG60C	

### 1200V Silicon Carbide High Voltage Schottky Diodes thinQ!<sup>TM</sup>



$I_F$ [A]	$Q_C$ [nC]	$I_{FSM}$ [A]	TO-252 DPAK	TO-263 D <sup>2</sup> PAK	TO-220 Real 2Pin	TO-220 FullPAK	TO-247-HC
2	7	14			IDH02SG120		
5	18	29			IDH05S120		
8	27	39			IDH08S120		
10	36	58			IDH10S120		IDY10S120
15	54	78			IDH15S120		IDY15S120

# Naming System

## thinQ!™ 2G

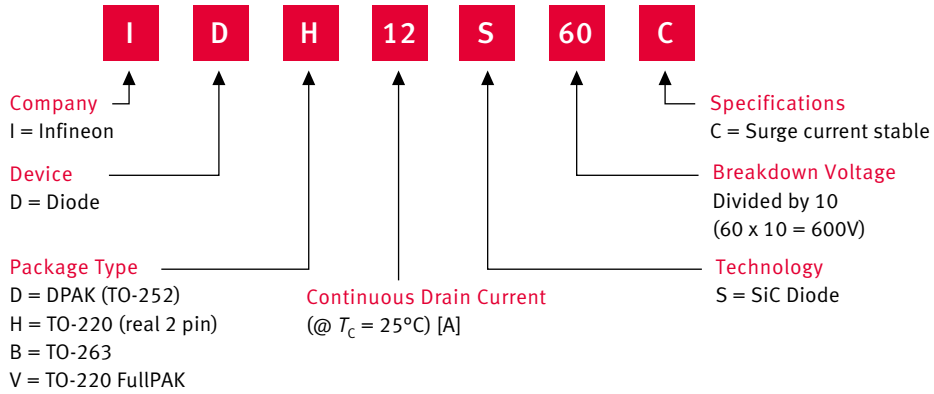

## thinQ!™ 3G

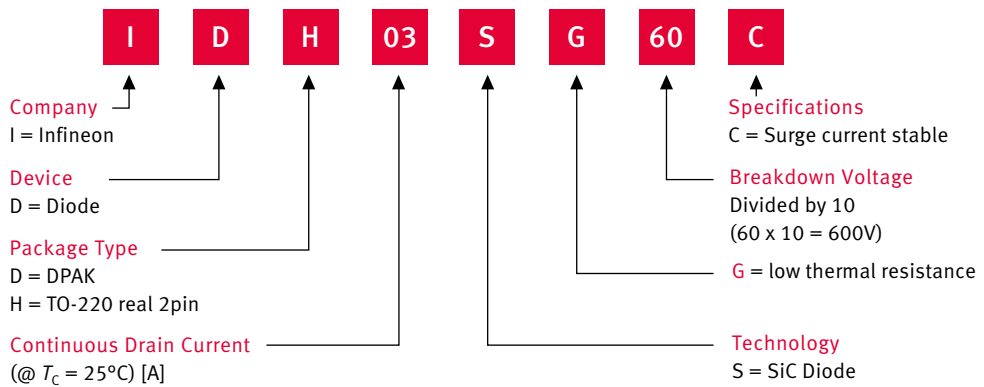

## thinQ!™ 1200 V

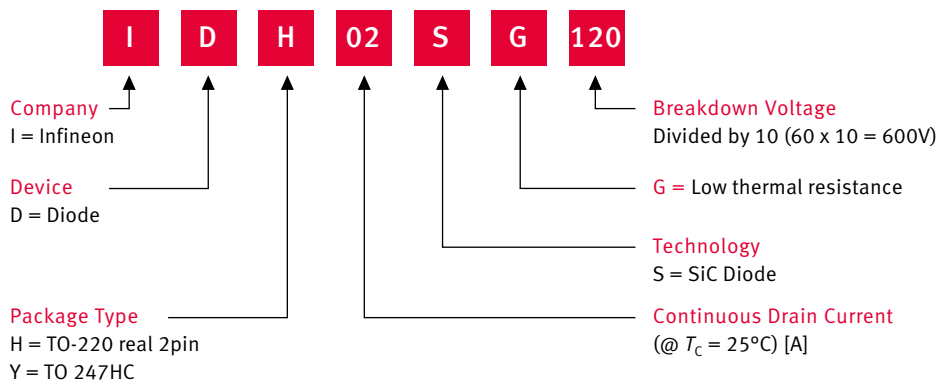

# Naming System

# IGBT

We are famous for IGBT technology leadership and offer a comprehensive portfolio for the general purpose inverter, solar inverter, UPS, Induction heating, Microwave Oven, Rice cooker, Automotive, Welding and SMPS segments.

## Benefits

- IGBT offer much higher current density than MOSFET power switches due to bipolar action
- Insulated gate allows bipolar performance with MOSFET gate drive performance
- High efficiency = smaller heat sink which leads to lower overall system cost

## IGBT versus MOSFET

Switching frequency is the main selection criteria of IGBT

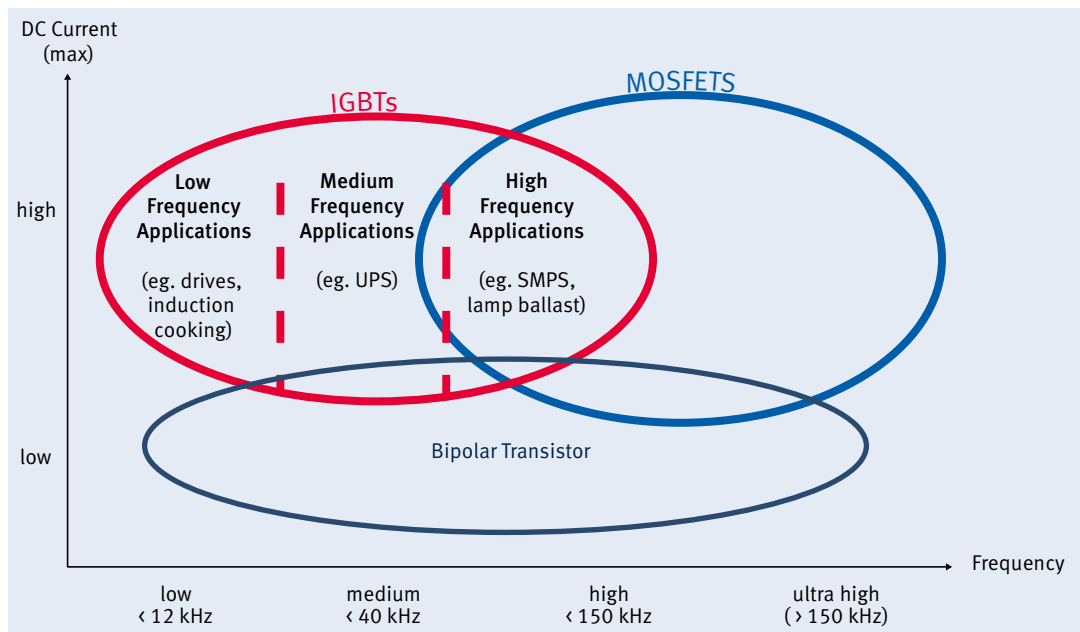

## Soft switching/resonant and hard topologies are comprehensively supported

Infineon has a huge portfolio addressing the following two switching techniques:

### Soft switching/resonant

- The world famous IHW series IGBTs

### Hard switching

- 600V RC-D IGBTs
- 600V RC-Drives Fast
- 600V TRENCHSTOP™ DuoPack™ IGBTs
- 600V HighSpeed 3

For IGBT usage, applications are divided into two switching techniques

Applications using soft switching/resonant technique	Applications using hard switching technique
Inverterised Microwave Oven	Inverterised major home appliances: Washing machines, dishwashers, fridges, air conditioning
Induction heating cook top	General purpose inverters
Induction heating rice cooker	Solar inverters
Office printers with induction heating used for ink and band-feed	Partial PFC stages
	Break IGBT
	UPS / Welding

## Discrete IGBT

- Number 1 worldwide supplier
- 1 in every 4 Discrete IGBTs sold comes from Infineon

### Features

- Low  $V_{ce(sat)}$  due to thin wafer technology
- Low switching losses
- High efficiency (cooler packages)
- Huge portfolio (current, voltage and package types)
- Excellent EMI behaviour
- Technical support for customers
- Solid logistic support
- Highest quality standards
- Leaders in IGBT Innovation

### Benefits

- Operating range up to 100kHz
- High efficiency devices optimised for lowest switching and conduction losses
- Cooler devices = smaller heat sinks
- Excellent EMI behaviour meaning smaller EMI filters
- Comprehensive portfolio
- Design support available on request

# Discrete IGBT Selection Tree

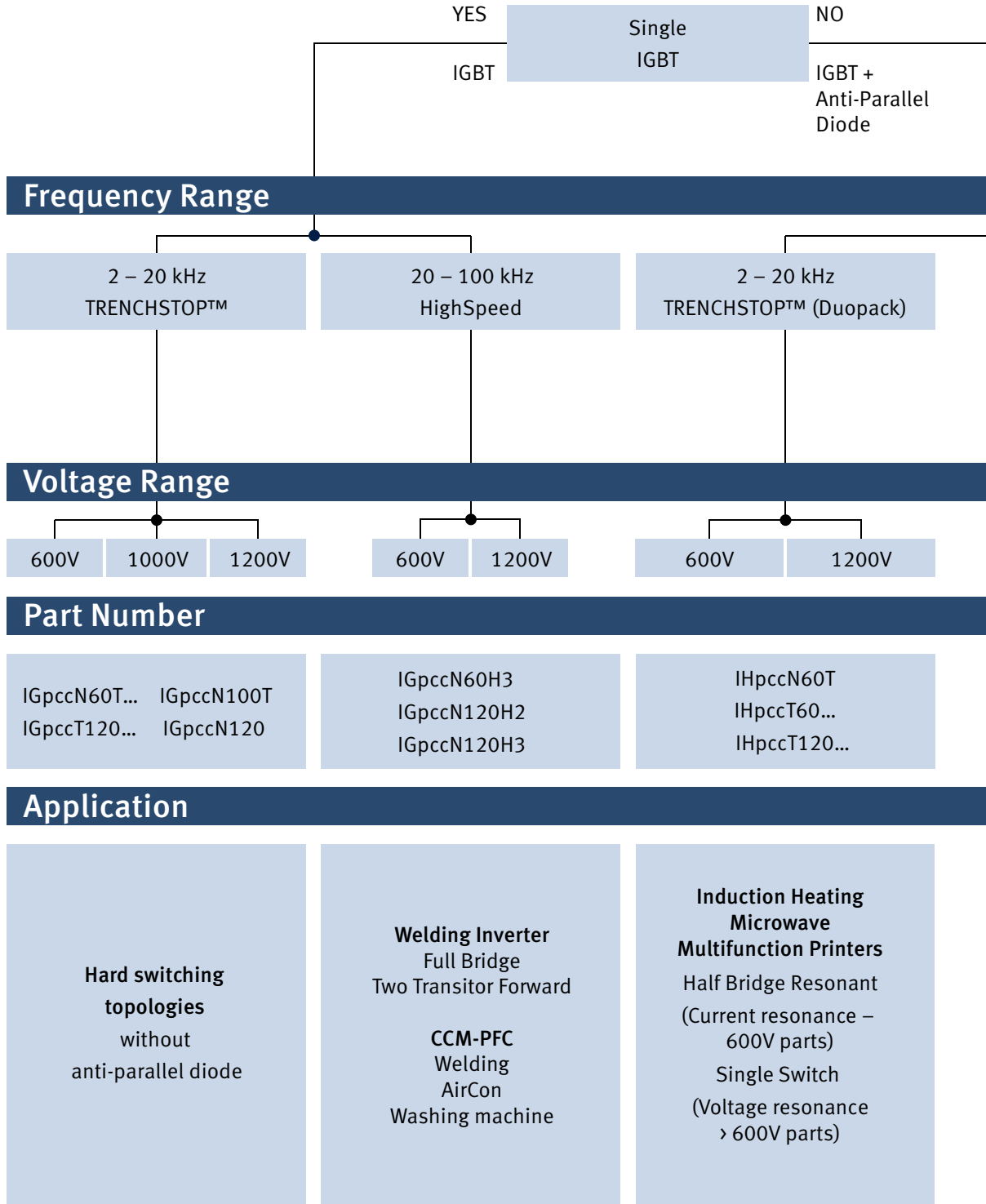

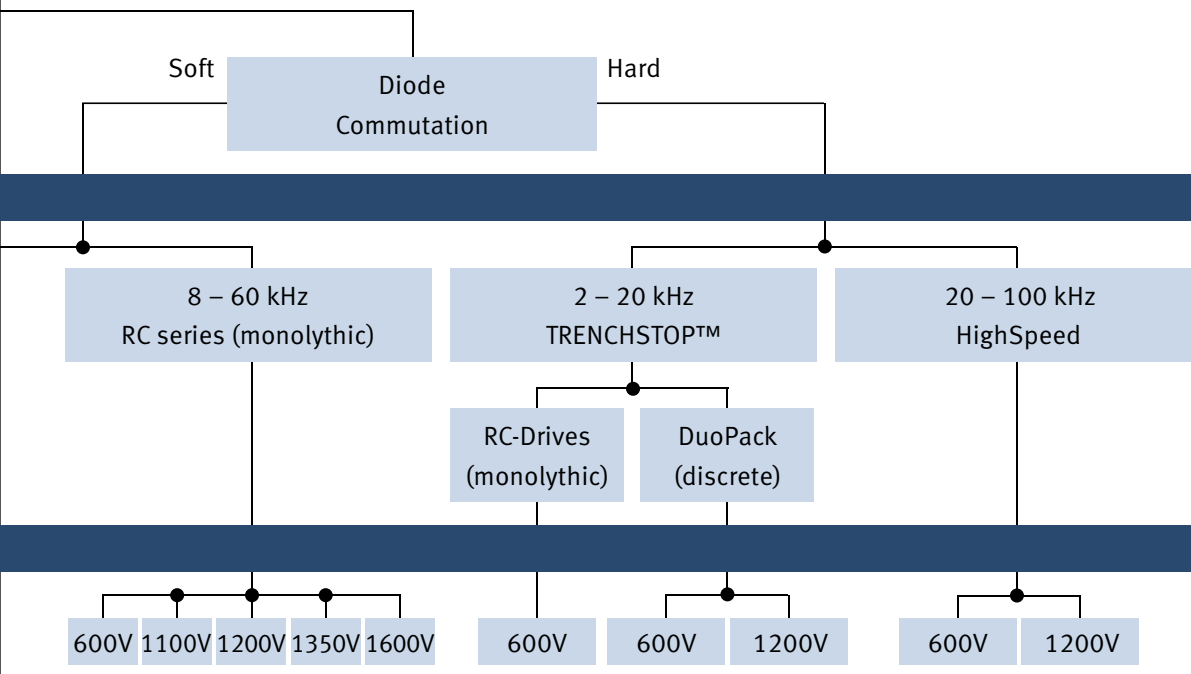

IHpccNvvvR2  
 IHpccNvvvR3 IHpccN600RA  
 IHpccT120... IHpccN600RF

IKpccN60R  
 IKpccN60RF

IKpccN60T  
 IKpccT120...  
 IKpccN120T2

IKpccN60H3  
 IKpccN120H2  
 IKpccN120H3

**Induction Heating**  
**Microwave**  
**Multifunction Printers**  
 Half Bridge Resonant  
 (Current resonance –  
 600V parts)  
 Single Switch  
 (Voltage resonance  
 > 600V parts)

**Solar Inverter**  
 Asymmetrical Bridge  
 Symmetrical full bridge  
 Three level type I or  
 Three level type II converter  
**Motor Control**  
 Three phase inverter  
 Full bridge inverter  
**UPS Bridge**  
 Uninterruptable Power Supply  
 Three level type II converter  
**Major Home Appliances**  
 Symmetrical full bridge

**Welding Inverter**  
 Full bridge inverter  
 Two Transistor Forward

## IGBT for Air Conditioning

Infineon is renowned for offering best in class discrete devices and ICs – now with the inverterised air conditioning reference board, Infineon can present system expertise in the fast growing inverterised air conditioning market.

### Features

- Assembly - Full power electronic SMD assembly example for high capacity production.
- Thermal behaviour - The inverter stages are driven with best in class current versus package size IGBTs, 15 A duo-packs in a DPAK (TO-252) package are used for driving a 1 kW compressor.
- Application tests show the case temperature staying below 110°C with an ambient temperature of 65°C. This provides more design freedom and a cost effective opportunity to replace IPMs in the inverter stage of the compressor and fan.
- High efficiency - the CCM PFC stage uses the latest generation HighSpeed 3 IGBT and SiC diode to achieve a PFC efficiency of > 97 %. SMD mounting and high current density high speed IGBT allow for improved PCB area optimisation.

For further information visit [www.infineon.com/aircon](http://www.infineon.com/aircon)

## RC-Drives Fast IGBTs

Drive high-frequency inverter for comfortable quietness . The RC-Drives IGBT technology was released by Infineon at the end of 2009 as a cost-optimized solution to address the price-sensitive consumer-drives market. This basic technology provides outstanding performance for permanent magnet synchronous and brushless DC motor drives. To meet the rising demand of the IGBTs for the low power motor drives consumer market, a new version of the RC-Drives IGBT was developed: the IGBT and diode losses are optimized to reduce the inverter losses at switching frequencies of 4~30kHz. This new family of Infineon's reverse conducting IGBT is called RC-Drives Fast. For consumer drives this series enables high efficient designs of inverters that feature operations above 16kHz to reduce the audible noise to an absolutely silent level. Furthermore highly precise vector control technologies can be used to provide more torque in operation at low speed and high performance dynamics in the control at high speed. The small footprint needed by the components enable high power density designs with less system cost.

### Preview

- Rapid Diode - Emitter controlled silicon diode family expansion targeting applications with switching speeds up to 50 kHz. Target application is >100W PFC.\*
- Automotive Discrete IGBT portfolio qualified to AEC-Q101. Target application is EV-aircon, PTC heater, and inverter drive; for diesel/gasoline vehicles HID lighting and Piezo-injection.\*

\* in development

## TRENCHSTOP™ IGBT and DuoPack™

600V Product Family



	$I_c$ (max.) [A]	TO-251	TO-252 DPAK Halogen-Free	TO-263 D <sup>2</sup> PAK Halogen-Free	TO-220 Halogen-Free	TO-262 Halogen-Free	TO-220 FullPAK Halogen-Free	TO-247
		Single IGBT	6				IGP06N60T	
10					IGP10N60T			
15				IGB15N60T	IGP15N60T			
20								
30				IGB30N60T	IGP30N60T			IGW30N60T
30								
40								
50				IGB50N60T	IGP50N60T			IGW50N60T
DuoPack™	75							IGW75N60T
	3		IKD03N60RF					
	4	IKU04N60R	IKD04N60RF IKD04N60R			IKI04N60T		
	6	IKU06N60R	IKD06N60R	IKB06N60T	IKP06N60T		IKA06N60T	
	10	IKU10N60R	IKD10N60R	IKB10N60T	IKP10N60T		IKA10N60T	
	15	IKU15N60R	IKD15N60R	IKB15N60T	IKP15N60T		IKA15N60T	
	20			IKB20N60T	IKP20N60T			IKW20N60T
	30							IKW30N60T
	50							IKW50N60T
75							IKW75N60T	

## TRENCHSTOP™ IGBT and DuoPack™

1200V Product Family



	$I_c$ (max.) [A]	TO-251	TO-252 DPAK Halogen-Free	TO-263 D <sup>2</sup> PAK Halogen-Free	TO-220 Halogen-Free	TO-262 Halogen-Free	TO-220 FullPAK Halogen-Free	TO-247	
								TRENCHSTOP™	TRENCHSTOP™ 2
Single IGBT	8							IGW08T120	
	15							IGW15T120	
	25							IGW25T120	
	40							IGW40T120	
	60							IGW60T120	
DuoPack™	8							IKW08T120	
	15							IKW15T120	IKW15N120T2
	25							IKW25T120	IKW25N120T2
	40							IKW40T120	IKW40N120T2

## TRENCHSTOP™ RC-H series

Portfolio for 600V, 1100V, 1200V, 1350V & 1600V



	$I_c$ (max.) [A]	TO-251	TO-252 DPAK	TO-263 D <sup>2</sup> PAK	TO-220	TO-262	TO-247 (IHW...) and TO-247HC (IHY...)				
			Halogen-Free	Halogen-Free	Halogen-Free	Halogen-Free	600V	1100V	1200V	1350	1600V
IGBT & Diode	15								IHW15T120		
									IHY15N120R3		
	15								IHW15N120R3		
	20									IHW20N135R3	
										IHY20N135R3	
	20									IHW20N120R3	
										IHY20N120R3	
	30							IHW30N60T	IHW30N110R3	IHW30N120R2	
30											IHY30N160R2
40							IHW40T60		IHW40T120		
40							IHW40N60R				
40							IHW40N60RF				

## HighSpeed2 IGBT and DuoPack™

1200V Product Family



	$I_c$ (max.) [A]	TO-251	TO-252 DPAK	TO-263 D <sup>2</sup> PAK	TO-220	TO-262	TO-220 FullPAK	TO-247
			Halogen-Free	Halogen-Free	Halogen-Free	Halogen-Free	Halogen-Free	Halogen-Free
IGBT	1		IGD01N120H2	IGB01N120H2	IGP01N120H2			
	3			IGB03N120H2	IGP03N120H2		IGA03N120H2	IGW03N120H2
DuoPack™	1			IKB01N120H2	IKP01N120H2			
	3			IKB03N120H2	IKP03N120H2		IKA03N120H2	IKW03N120H2

## HighSpeed 3 IGBT and DuoPack™

600V Product Family



	$I_c$ (max.) [A]	TO-251	TO-252 DPAK	TO-263 D <sup>2</sup> PAK	TO-220	TO-262	TO-220 FullPAK	TO-247
			Halogen-Free	Halogen-Free	Halogen-Free	Halogen-Free	Halogen-Free	Halogen-Free
IGBT	20			IGB20N60H3	IGP20N60H3			
	30			IGB30N60H3	IGP30N60H3			
	40							IGW40N60H3
	50							IGW50N60H3
	60							IGW60N60H3
	75							IGW75N60H3
DuoPack™	100							IGW100N60H3
	20			IKB20N60H3	IKP20N60H3			IKW20N60H3
	30			IKB30N60H3	IKP30N60H3			IKW30N60H3
	40							IKW40N60H3
	50							IKW50N60H3
	60							IKW60N60H3
75							IKW75N60H3	

\* in development

## HighSpeed 3 IGBT and DuoPack™

1200V Product Family



	$I_c$ (max.) [A]	TO-251	TO-252 DPAK Halogen-Free	TO-263 D <sup>2</sup> PAK Halogen-Free	TO-220 Halogen-Free	TO-262 Halogen-Free	TO-220 FullPAK Halogen-Free	TO-247
IGBT	15							IGW15N120H3
	25							IGW25N120H3
	40							IGW40N120H3
DuoPack™	15							IKW15N120H3
	25							IKW25N120H3
	40							IKW40N120H3

## Discrete Emitter Controlled Diodes

600V and 1200V



	$I_c$ (max.) [A]	TO-251	TO-252 DPAK Halogen-Free	TO-263 D <sup>2</sup> PAK Halogen-Free	TO-220 real 2 pin Halogen-Free	TO-220 real 2pin FullPAK Halogen-Free		TO-247
						600V	650V	
600V / 650V	3		IDD03E60					
	6		IDD06E60		IDP06E60			
	9		IDD09E60	IDB09E60			IDV08E65D*	
	15		IDD15E60	IDB15E60	IDP15E60			
	23			IDB23E60	IDP23E60		IDV20E65D*	
	30			IDB30E60	IDP30E60	IDV30E60C		
	45			IDB45E60	IDP45E60			
	75							IDW75E60
1200V	100							IDW100E60
	4				IDP04E120			
	9				IDP09E120			
	12			IDB12E120	IDP12E120			
	18			IDB18E120	IDP18E120			
30			IDB30E120	IDP30E120				

IGBT

# Naming System

## Discretes IGBT and Emitter Controlled Diodes

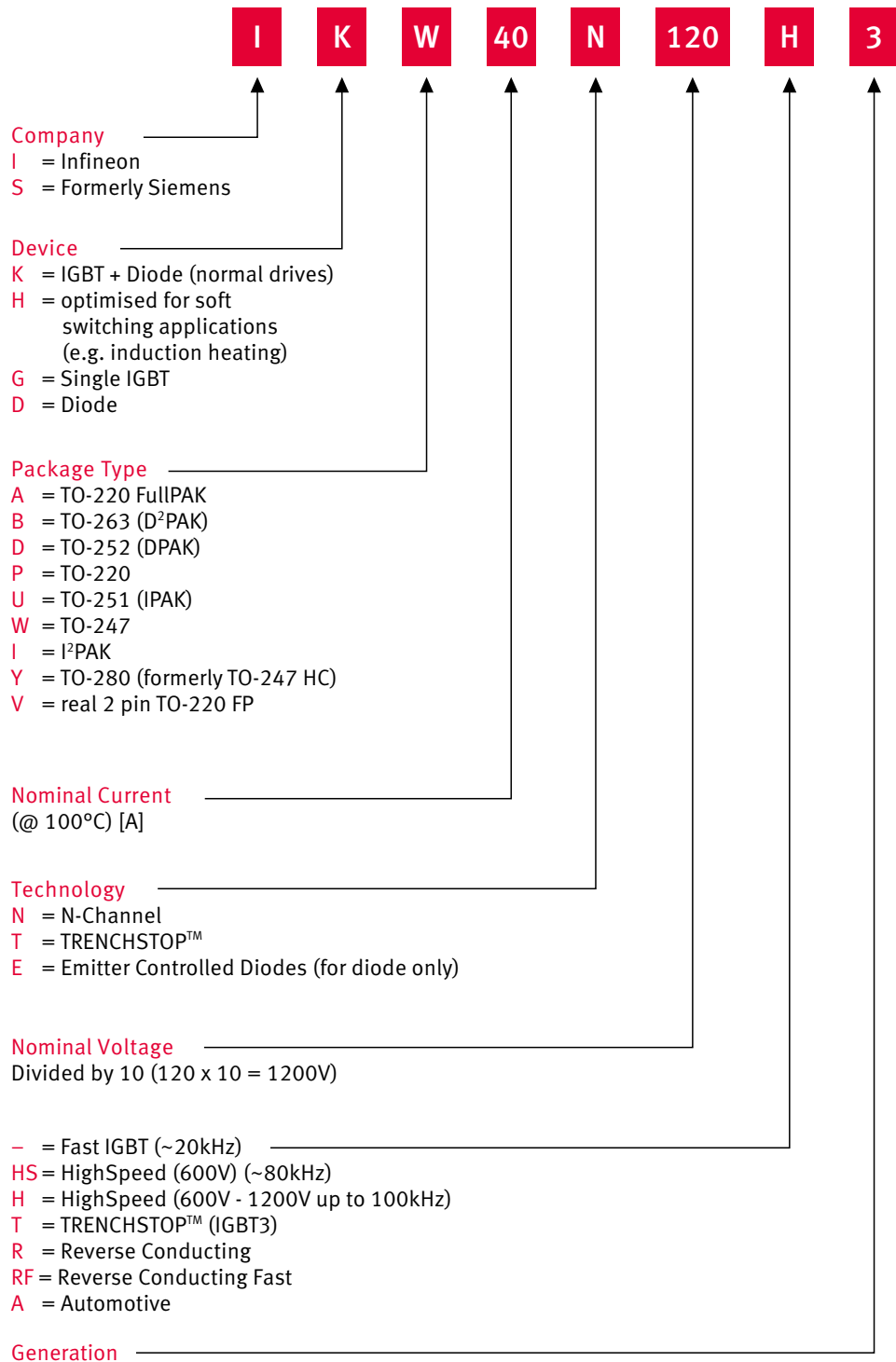



# Power Factor Correction and Combo Controller

## Discontinuous Conduction Mode PFC ICs

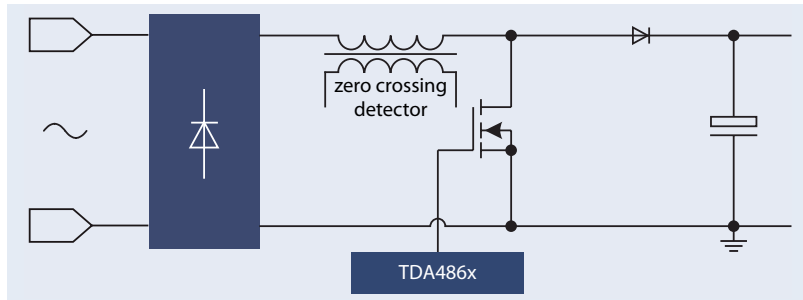

### TDA4862

Power Factor Controller (PFC) IC for high-power factor and active harmonic filter

- IC for sinusoidal line-current consumption
- Power factor approaching 1
- Controls boost converter as an active harmonics filter
- Internal start-up with low current consumption
- Zero current detector for discontinuous operation mode
- High current totem pole gate driver
- Trimmed  $\pm 1.4\%$  internal reference
- Undervoltage lock out with hysteresis
- Very low start-up current consumption
- Pin compatible with world standard
- Output overvoltage protection
- Current sense input with internal low pass filter
- Totem pole output with active shutdown during UVLO
- Junction temperature range  $-40$  to  $+150^{\circ}\text{C}$
- Available in DIP-8 and SO-8 packages

### TDA4863 / TDA4863-2

Power Factor Controller IC for high-power factor and low THD additional features to TDA4862

- Reduced tolerance of signal levels
- Improved light load behavior
- Open loop protection
- Current sense input with leading edge blanking LEB
- Undervoltage protection

## Continuous Conduction Mode PFC ICs

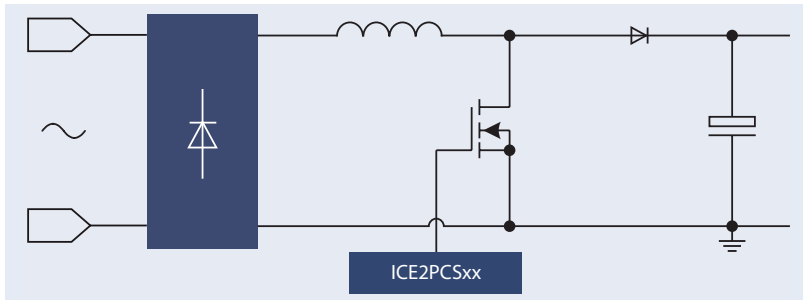

## 2<sup>nd</sup> Generation Continuous Conduction Mode (CCM) Power Factor Correction IC Features

- Fulfills Class D Requirements of IEC 61000-3-2
- Lowest count of external components
- Adjustable and fixed sw frequencies
- Frequency range from 20kHz to 285kHz
- Versions with brown-out protection available
- Wide input range supported
- Enhanced Dynamic Response during Load Jumps
- Cycle by Cycle Peak Current Limiting
- Integrated protections OVP, OCP
- DIP8 and DSO8
- Leadfree, RoHS compliant

### 2nd Generation Continuous Conduction Mode (CCM) Power Factor Correction IC Product Portfolio

Product	Frequency <sub>(sw)</sub>	Current Drives	Package
ICE2PCS01	50kHz - 285kHz	2.0A	DIP-8
ICE2PCS02	65kHz	2.0A	
ICE2PCS03	100kHz	2.0A	
ICE2PCS04	133kHz	2.0A	
ICE2PCS05	20kHz - 250kHz	2.0A	
ICE2PCS01G	50kHz - 250kHz	2.0A	DSO-8
ICE2PCS02G	65kHz	2.0A	
ICE2PCS03G	100kHz	2.0A	
ICE2PCS04G	133kHz	2.0A	
ICE2PCS05G	20kHz - 250kHz	2.0A	

## 3<sup>rd</sup> Generation Continuous Conduction Mode (CCM) Power Factor Correction IC Features

- Fulfills Class D Requirements of IEC 61000-3-2
- Integrated digital voltage loop compensation
- Boost follower function
- Bulk voltage monitoring signals, brown-out
- Multi protections such as Double OVP
- Fast output dynamic response during load jump
- External synchronization
- Extra low peak current limitation threshold
- SO8 and SO14
- Leadfree, RoHS compliant

### Fixed Frequency PWM IC and CoolSET™ Product Portfolio

Product	Frequency <sub>(SW)</sub>	Current Drives	Features	Package
ICE3PCS01G	Adjustable	0.75A	OVP+Brown-out	DSO-14
ICE3PCS02G		0.75A	OVP	DSO-8
ICE3PCS03G		0.75A	Brown-out	DSO-8

## Combination of Continuous Conduction Mode PFC with Two-Transistor Forward PWM IC

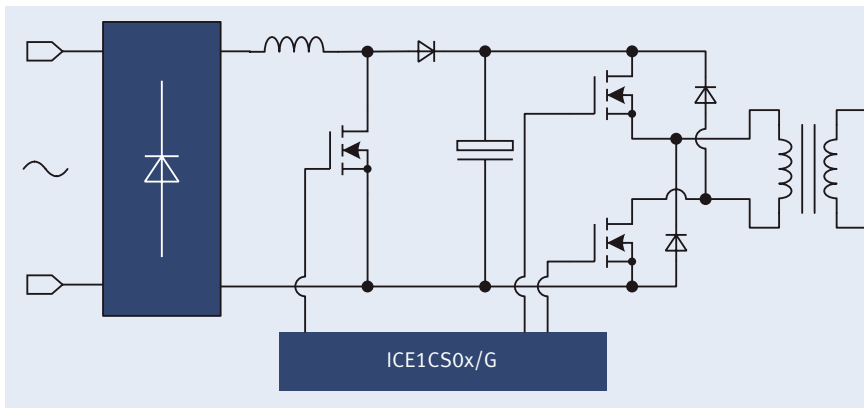

- Pre-short Protection
- Trimmed Reference Voltage  $\pm 2.5\%$  ( $\pm 2\%$  at  $25^\circ\text{C}$ )
- BiCMOS technology for wider  $V_{CC}$  Range

### Power Factor Correction Block

- Fulfills Class D Requirements of IEC 61000-3-2
- Fixed switching frequency (sync to half PWM freq.)
- AC brown-out protection
- Average Current Control
- Max Duty Cycle of 95%
- Enhanced Dynamic Response for fast load response
- Unique Soft-Start to Limit Start Up Current
- Over-Voltage Protection

### Pulse-Width-Modulation Block

- Fixed Switching Frequency
- Option for external control synchronization
- Built in Soft Start for higher reliability
- Max Duty Cycle 47% or 60%
- Overall Tolerance of Current Limiting  $\leq \pm 5\%$
- Internal Leading Edge Blanking
- Slope Compensation
- Fast, soft switching totem pole gate drive (2A)
- SO16 and DIP16
- Pb-free lead plating and RoHS compliant
- All protection features available

Product	Frequency <sub>(SW)</sub>	Current Drives	Package
ICE1CS02	PFC=65kHz	2.0A	DIP-16
ICE1CS02G	PWM=130kHz	2.0A	DSO-16

## Resonant LLC Half-Bridge Controller IC

### LLC Resonant (No SR)

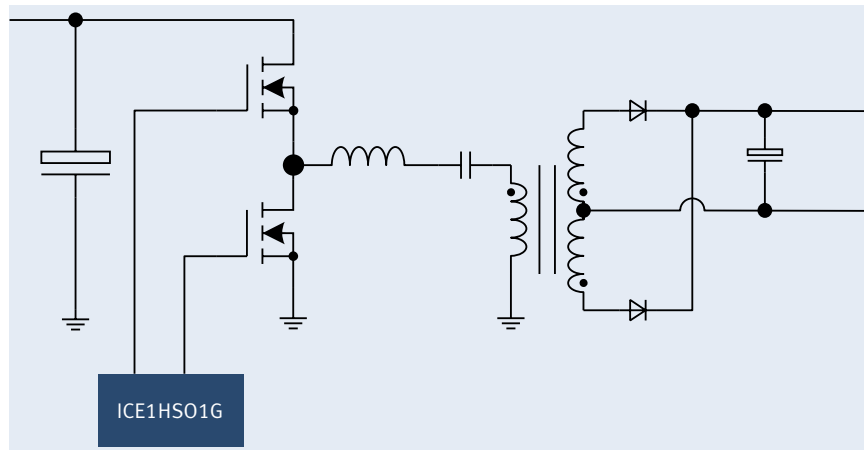

- Novel and simple design (12 components + HB driver)
- Minimum operating frequency is adjustable externally
- Burst mode operation for output voltage regulation during no load and/or bus over-voltage
- Multiple protections in case fault
- Input voltage sense for brown-out protection
- Open loop/over load fault detection by FB pin with auto-restart and adjustable blanking/restart time
- Frequency shift for over-current protection
- Lead Free, RoHS compliant package
- DSO-8 package

Product	Frequency <sub>(sw)</sub>	Dead Time(ns)	Current Drives	Package
ICE1HS01G	30kHz~600kHz	380	1.5A	DSO-8

## Resonant LLC Half-Bridge Controller IC with Integrated Synchronised Rectifier control

### LLC Resonant + SR

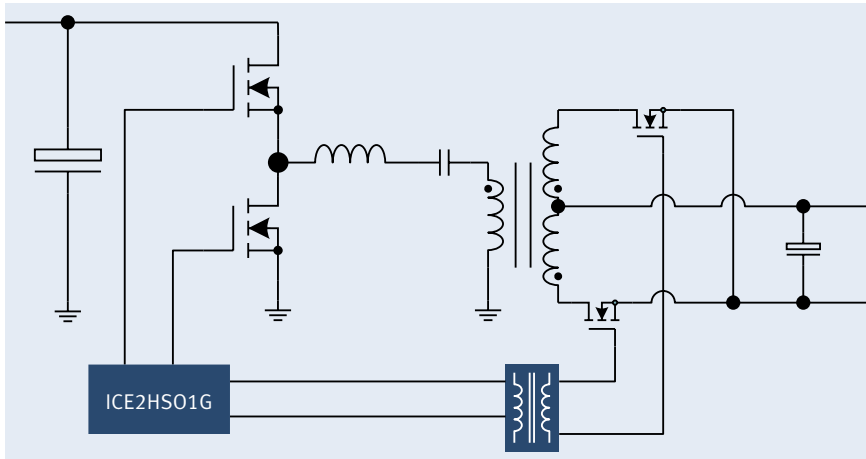

- Novel LLC/SR operation mode and controlled by primary side controller
- Multiple protections for SR operation
- Tight tolerance control
- Accurate setting of switching frequency and dead time
- Simple system design
- Optimized system efficiency
- Multiple converter protections: OTP, OLP, OCP, Latch-off Enable
- External disable for either SR switching or HB switching
- Lead Free, RoHS compliant package
- DSO-20 package

Product	Frequency <sub>(SW)</sub>	Dead Time(ns)	Current Drives	Package
ICE2HS01G	30kHz~1MHz	125ns~2us	0.3A	DSO-20

## Climate Saver Standard and Bronze

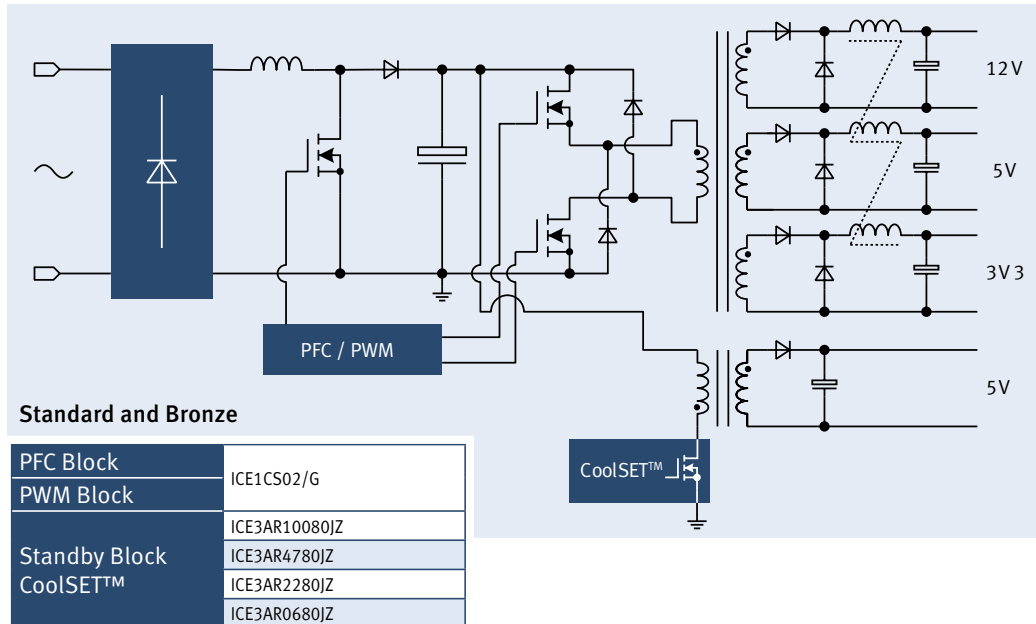

## Climate Saver Silver

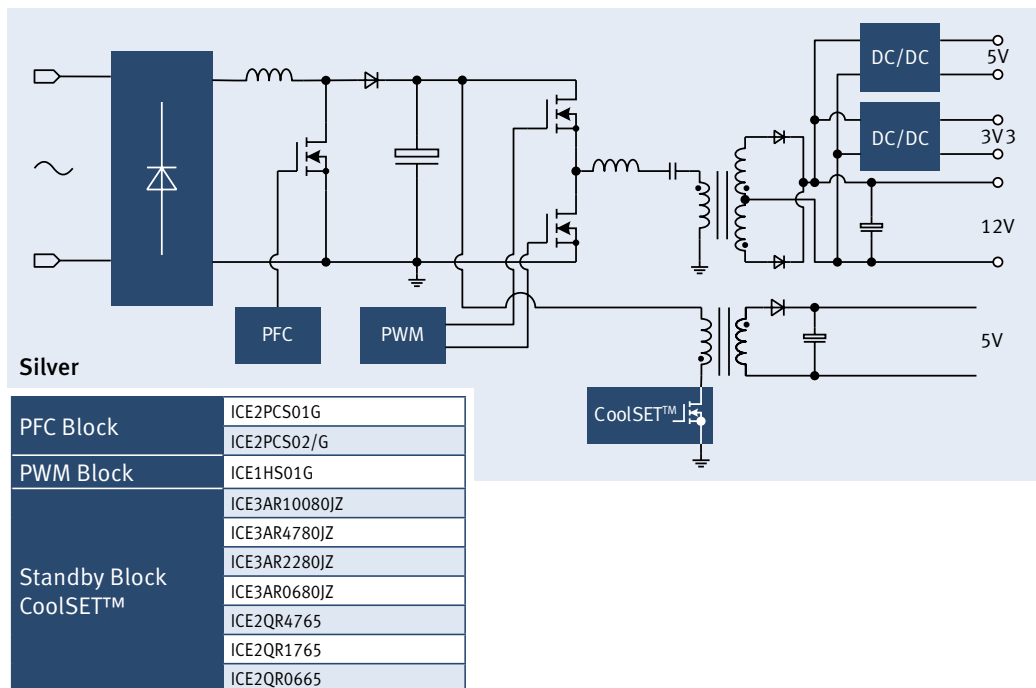

## Climate Saver Gold

## Climate Saver 80 PLUS® Platinum

certification for Infineon's Silverbox reference design

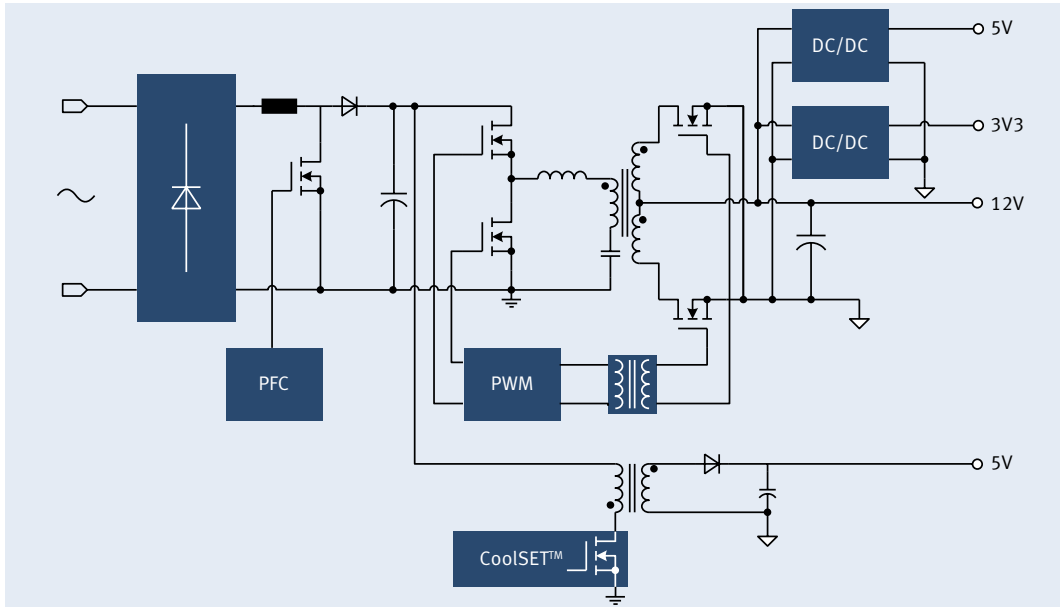

### Gold

PFC Block	ICE2PCS01G
	ICE2PCS02/G
PWM Block	ICE1HS01G
	ICE2HS01G
Standby Block CoolSET™	ICE3AR10080JZ
	ICE3AR4780JZ
	ICE3AR2280JZ
	ICE3AR0680JZ
	ICE3BR2280JZ
	ICE3BR0680JZ

### 80 PLUS® Platinum

certification for Infineon's Silverbox reference design

PFC Block	ICE3PCS01G
	ICE3PCS02G
	ICE3PCS03G
PWM Block	ICE2HS01G
Standby Block CoolSET™	ICE2QR4780Z
	ICE2QR2280Z
	ICE2QR0680Z
	ICE2QR2280G

For further information visit [www.infineon.com/silverbox](http://www.infineon.com/silverbox)

# Isolated AC/DC

## Quasi-resonant PWM IC and CoolSET™ Features

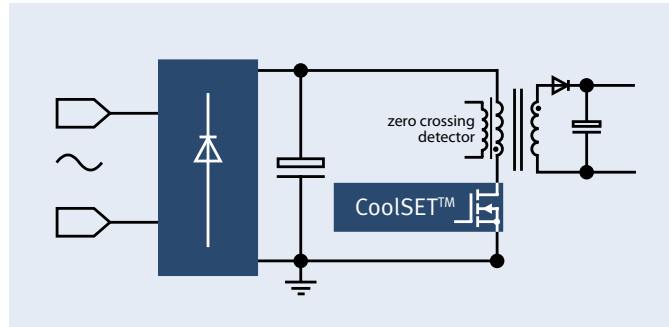

- Integrated 650V CoolMOS™ or HV start-up cell for IC self-power supply
- Quasi-Resonant operation with Digital Frequency Reduction
- High average efficiency over wide load range
- Stable operation without jittering/audible noise problem
- Active burst mode operation for very low stby losses (to achieve standby power <100mW)
- Auto restart mode for  $V_{CC}$  under-voltage/over-voltage protection
- Auto restart mode for open-loop and output overload protection
- Auto restart mode for over-temperature protection
- Latch-off mode for output over-voltage, short-winding
- BiCMOS Technology (controller) for wide  $V_{CC}$  operation and low IC power consumption
- Peak power limitation with input voltage compensation
- Minimum switching frequency limitation (no audible noise on Power Units On/Off)
- DIP & DSO Package (for controllers and CoolSET™)
- PB-free Plating and RoHS compliance

### Quasi-resonant PWM IC and CoolSET™ Product Portfolio

Product	$V_{DS}$ (breakdown)	$R_{(DS)on}$	Power (Universal)	Package
ICE2QS01				DIP-8
ICE2QS02G				DSO-8
ICE2QS03				DIP-8
ICE2QS03G				DSO-8
ICE2QR4765	650V	4.7Ω	19W	DIP-8
ICE2QR1765	650V	1.7Ω	33W	DIP-8
ICE2QR0665	650V	0.6Ω	50W	DIP-8
ICE2QR4780Z	800V	4.7Ω	22W	DIP-7
ICE2QR2280Z	800V	2.2Ω	31W	DIP-7
ICE2QR0680Z	800V	0.6Ω	57W	DIP-7

## Fixed Frequency PWM IC and CoolSET™ Features

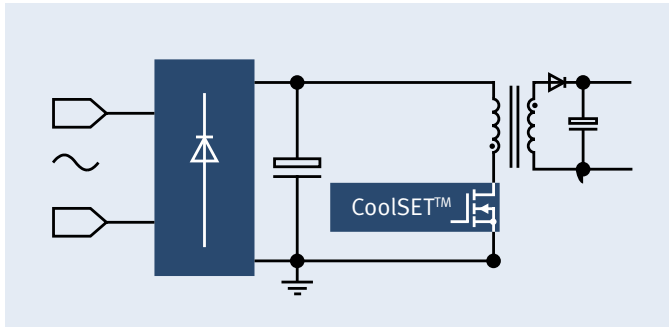

- Active Burst Mode to achieve the lowest Standby Power Requirements < 50 mW
- Optional Latched Off Mode (L) to increase robustness and safety of the system
- Adjustable Blanking window for high load jumps to increase reliability
- Startup Cell switched off after Start Up
- 65kHz/10kHz/130kHz internally fixed Switching Frequency
- Over-temperature, over-voltage, short-winding, overload and open-loop,  $V_{CC}$  Under-voltage, (Brown-out) protections
- Fixed softstart time
- Overall Tolerance of Current Limiting <  $\pm 5\%$
- Internal Leading Edge Blanking Time
- Max duty cycle 72%
- PB-free Plating and RoHS compliance
- DIP, DSO and FullPAK packages

### Fixed Frequency PWM IC and CoolSET™ Product Portfolio

Product	Frequency <sub>(SW)</sub>	$V_{DS}$ (breakdown)	$R_{(DS)on}$	Power (Universal)	Package
ICE3AS03LJG	100kHz				DSO-8
ICE3BS03LJG	65kHz				DSO-8
ICE3GS03LJG	130kHz				DSO-8
ICE3BR4765J	65kHz	650V	4.7 $\Omega$	18W	DIP-8
ICE3BR1765J	65kHz	650V	1.7 $\Omega$	31W	DIP-8
ICE3BR0665J	65kHz	650V	0.6 $\Omega$	49W	DIP-8
ICE3BR4765JZ	65kHz	650V	4.7 $\Omega$	18W	DIP-7
ICE3BR1765JZ	65kHz	650V	1.7 $\Omega$	30W	DIP-7
ICE3BR0665JZ	65kHz	650V	0.6 $\Omega$	47W	DIP-7
ICE3BR4765JG	65kHz	650V	4.7 $\Omega$	17W	DSO-12
ICE3A1065ELJ	100kHz	650V	3.0 $\Omega$	16W	DIP-8
ICE3A2065ELJ	100kHz	650V	1.0 $\Omega$	28W	DIP-8
ICE3AR10080JZ	100kHz	800V	10.0 $\Omega$	10W	DIP-7
ICE3AR4780JZ	100kHz	800V	4.7 $\Omega$	20W	DIP-7
ICE3AR2280JZ	100kHz	800V	2.2 $\Omega$	28W	DIP-7
ICE3AR0680JZ	100kHz	800V	0.6 $\Omega$	52W	DIP-7
ICE3BR2280JZ	65kHz	800V	2.2 $\Omega$	28W	DIP-7
ICE3BR0680JZ	65kHz	800V	0.6 $\Omega$	52W	DIP-7

# Non-Isolated DC/DC

## MOSFET Gate Driver IC

### PX3516

#### Features

- Dual MOSFET driver for synchronous rectified bridge converters
- Adjustable high-side and low-side MOSFET gate drive voltages for optimal efficiency
- Integrated bootstrap diode for reduced part count
- Adaptive gate drive control prevents cross-conduction
- Fast rise and fall times supports switching rates of up to 2MHz
- Capable of sinking more than 4A peak current for low switching losses
- Three-state PWM input for output stage shutdown
- $V_{CC}$  under-voltage protection
- Lead-free (RoHS compliant) SOIC and DFN packages

Gate Driver	PX3516
Package	TDSO10
RoHS-compliant	Y
Number of channels	1
Maximum junction temperature	0°C to 125°C
Supply voltage, $V_{CC}$	+4.5V to 6,5V
BOOT to GND	30
PWM Inputs	1.15, 2.10
Quiescent current $I_q$	410uA

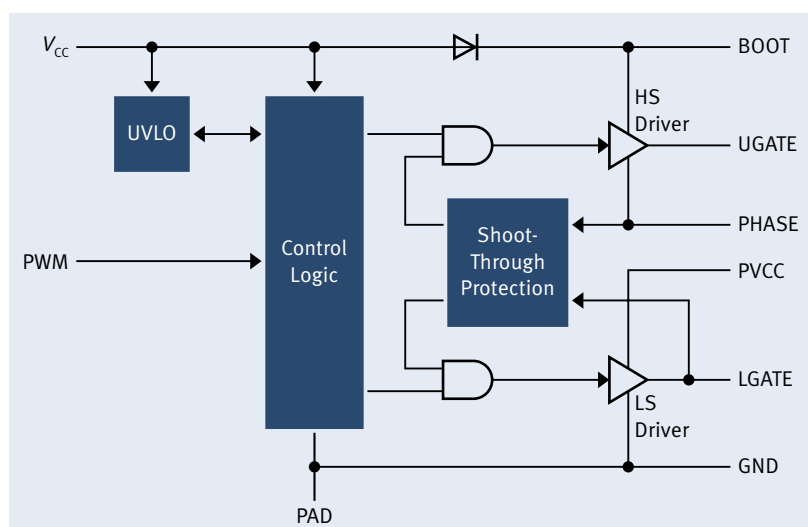

## 6 x 6 IQFN High-Performance DrMOS (Driver+MOS)

### TDA21211 / TDA21220

#### Features

- Intel compliant DrMOS, Power MOSFET and Driver in one package
- For Synchronous Buck - step down voltage applications
- Wide input voltage range 5V ... 25V
- High efficiency
- Extremely fast switching technology for improved performance at high switching frequencies
- Remote Driver Disable function
- SMOD–Switching Modulation of low side MOS
- Extremely Robust Switch Node -20V ... 30V for added reliability in noisy applications
- Includes active PMOS structure as integrated bootstrap circuit for reduced part count
- Adaptive Gate Drive for shoot through protection
- 5V High and Low Side Driving voltage
- Compatible to standard PWM controller ICs with 3.3V and 5V logic
- Three-State functionality
- Small Package: IQFN-40 (6 x 6 x 0.8 mm<sup>3</sup>)
- RoHS Compliant (Pb Free)

For further information visit [www.infineon.com/drmos](http://www.infineon.com/drmos)

	TDA 21211	TDA 21220
Input Voltage	30V	16V
SMOD function	Low Side	Low Side
Super Barrier Diode	-	-
Thermal warning/ shutdown	-	-
Max average load current	35A	50A
MOSFET Voltage	30V	25V
Schottky Diode	Included	Included
PWM levels	compatible +3.3V / +5V (tolerant)	compatible +3.3V / +5V (tolerant)
Shoot through protection	Included	Included

DrMOS application diagram

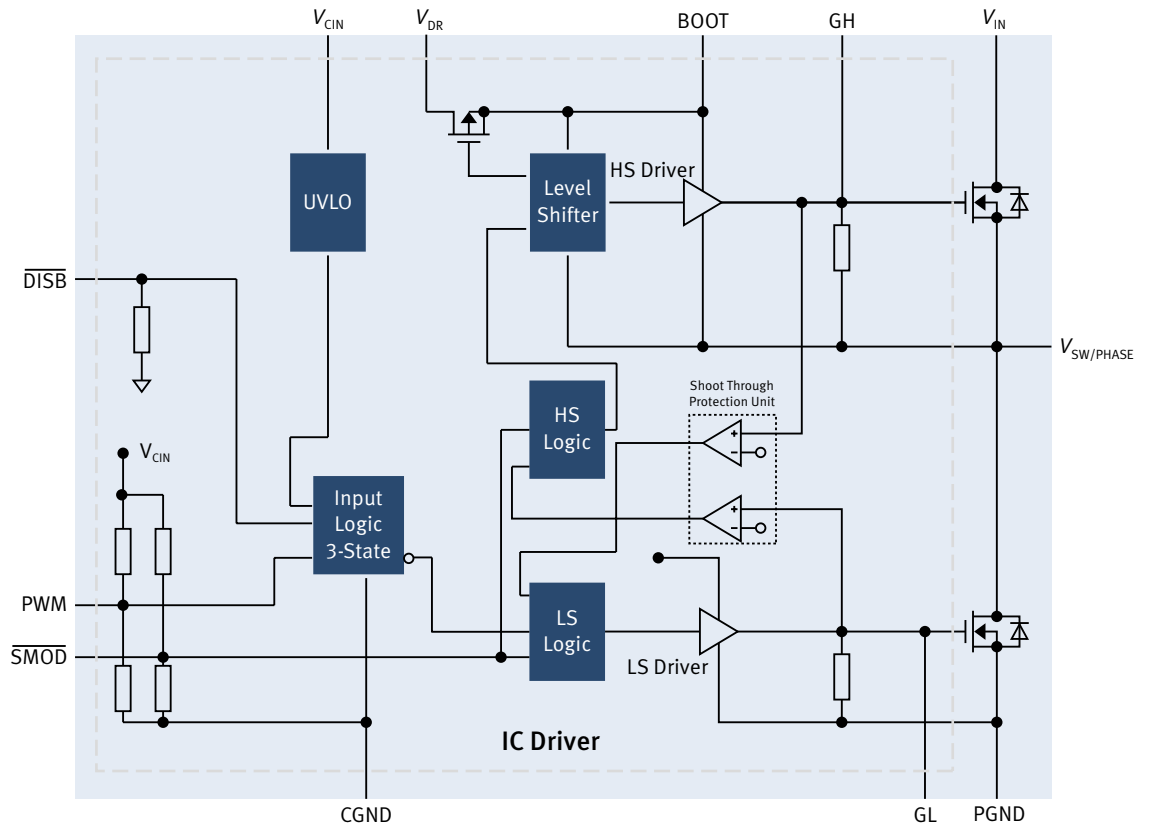

## Digital Controllers for Core and Memory Power

As microprocessors and ASICs have grown in power and complexity, their voltage regulation requirements have become increasingly demanding. This growing complexity has led to the introduction of Primarion Digital Power Management (DPM) solutions with increased accuracy, real-time monitoring and control capabilities via digital communications bus. The simplified system design the DPM solution provides leads to lower cost and higher performance implementations.

Primarion's Core Power ICs are designed into voltage regulator modules (VRMs) and motherboards for leading server original equipment manufacturers (OEMs) and are currently shipping into major server OEM systems to power CPU and GPU.

Primarion's digital power system-level solutions enable improved digital control features: better accuracy and use of lower cost passive components through adaptive digital calibration, improved ability to respond to fast changes in power requirements (transients) using fewer external capacitors with proprietary Active Transient Response (ATR), and easier design-in with a graphical user interface. Primarion's overall solution requires substantially fewer components and associated costs as compared to current analog power solutions.

Infineon/Primarion PowerCode™ is a software tool which greatly simplifies the configuration and performance optimization of Infineon digital controllers. It provides an intuitive Graphical User Interface (GUI) that runs on Microsoft Windows. The program comes with an automated design wizard that guides design engineers through the process of configuring single or multi-chip systems. Factory default configurations are supplied which can be easily modified through a variety of dialogs. Range checking and error detection ensure proper configuration.

### Additional features included are:

- Chip detection
- Real-time telemetry and temperature information
- Fault detection and clearing
- System file editing
- Bode plots and load models
- Current Sense network design
- Phase and Frequency adjustment
- Input and Output settings
- Access to PMBus programming

# Fan Speed Controller

## TDA21801

With the fan speed controller TDA21801, essential system monitoring features of switched mode power supplies (SMPS) such as adjustable minimum fan speed, fan ON/OFF and overtemperature protection (OTP) can be easily implemented. Only few external components added to the IC are necessary for it.

The TDA21801 is designed for applications using 3- or 4-wire fan solutions like PC silver boxes, Server silver box AC/DC converter and industrial/medical power supplies.

### Benefits

- Full control over fan speed due to precision reference
- Low system cost when replacing 4-wire fans
- Reduced noise level
- Increased safety of power supplies

### Features

- In combination with 2-wire fans same functionality as 4-wire fan solution
- Overtemperature protection feature to protect system and power supply
- Adjustable minimum fan speed (750 to 4000rpm)
- Fan speed can be increased by external PWM or analogue signal
- SO-8 Package/RoHS compliant

# Lighting ICs

## Smart Ballast Controller

Smart Ballast Control ICs from Infineon integrate all of the lamp start, run and protection features required by current and future Fluorescent Lamp Ballasts. Digital Mixed Signal Power Control is employed enabling speedy, cost effective and stable ballast designs with the minimum of external components. Reliable and robust high voltage isolation is achieved using Infineon's proprietary Coreless Transformer Technology (CLT).

- Integrated High Performance PFC Stage
- Intelligent Digital/Mixed Signal Power Control
- Integrated High Voltage Half Bridge Driver
- All Parameters set using only resistors
- Highly accurate timing and frequency control over a wide temperature range

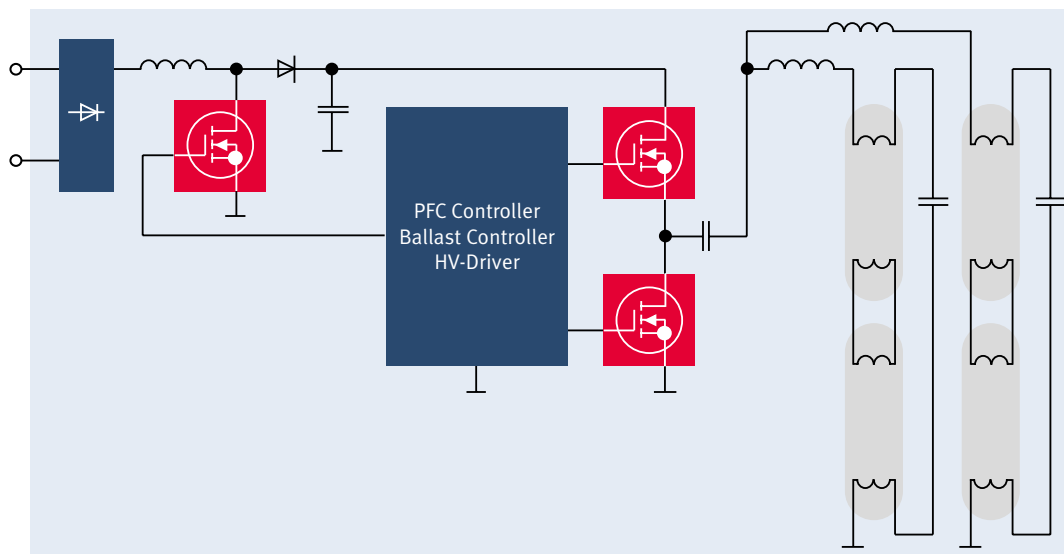

## Feature Comparison 1<sup>st</sup> & 2<sup>nd</sup> Generation Smart Ballast Controllers

Feature	Benefit	ICB2FL01 G	ICB1FL02 G
Stable operation during ignition even close to magnetic saturation of the resonant choke.	Reduced Lamp Choke Size (BOM costs)	✓	–
Special In-circuit test mode for faster test time.	Dramatically reduced time for key tests such as End of Life detection, preheat / Ignition Timeout and Pre Run operation modes	✓	–
Separate adjustable levels of Lamp Overload and Rectifier Effect detection.	Enables Ballast compatibility with a wider range of lamp types. Enhanced functionality with series connected lamps	✓	Fixed
Adjustment of the preheat time	Flexible support of both Current and Voltage mode pre-heating	0-2500ms	0–2000ms
No High Voltage Capacitor required for detection of Lamp removal (Capacitive mode operation)	Reduced BOM costs	✓	–
Intelligent discrimination between Surge & EOL events	Lamp can automatically restart following surge events without compromising End of Life event handling	✓	–
Skipped preheating when line interruption < 500ms.	Meets standards for emergency lighting (according to DIN VDE 0108)	✓	–
Excellent dynamic PFC performance enables very low THD across wide load ranges	Suitable for Dimming & Multi Power Ballasts	✓	–
Self adapting Dead Time adjustment of the Half Bridge driver.	Eases design of Multi-Power Ballasts and reduces EMI	✓	Fixed
One single restart at fault mode	Enhanced reliability of ballast	✓	–

## ICB2FL01 G

Infineon's 2<sup>nd</sup> Generation Smart Ballast Controller ICB2FL01 G is designed to control a fluorescent lamp ballast including

- Power Factor Correction (PFC)
- Lamp Inverter Control and
- High voltage level-shift half bridge driver with Coreless Transformer Technology<sup>1</sup> in one package

### Product Highlights

- Critical Conduction Mode PFC with overcurrent and overvoltage protection and internal loop compensation
- Very low THD and harmonic distortion for low power application in DCM
- Improved ignition control for an operation close to the magnetic saturation
- High reliability and minimized spread due to digital and optimized analog control functions
- Adjustable End-of-Life Detection in Multi Lamp Topologies and detection of Capacitive Mode Operation
- Meets Emergency Lighting Standards
- Suitable for Dimming

Short Form Data	min.	typ.	max.
Package	SO-19		
Operating voltage range	10V	–	17.5V
Turn-on threshold	–	14V	
Supply current during UVLO and fault mode	–	110µA	170µA
Operating frequency of inverter during RUN mode	20kHz	–	120kHz
Operating frequency of inverter during preheating mode	$F_{RFRUN}$	–	150kHz
Preheating time	0ms	–	2500ms
Adjustable self-adapting dead time max between LS and HS gate drive	2.25µs	2.50µs	2.75µs
Adjustable self-adapting dead time min between LS and HS gate drive	1.00µs	1.25µs	1.50µs
Operating voltage range of floating HS gate drive	-900V	–	+900V
LS Current limitation threshold: Ignition/start up/soft start/pre run	1.5V	1.6V	1.7V
LS Current protection threshold during RUN mode and preheating	0.75V	0.80V	0.85V
End-of-life detection threshold	-40µA	–	+40µA
Detection of non-ZVS operation CapMode 1 & 2	–	–	–
PFC preconverter control with critical and discontinuous CM	–	–	–
Maximum controlled on-time	18µs	22.7µs	26µs
Hysteresis of zero current detector	–	1.0V	–
PFC Current limitation threshold	–	1.0V	–
Reference voltage for control of bus voltage	2.47V	2.5V	2.53V
Overvoltage detection threshold	2.68V	2.73V	2.78V
Undervoltage detection threshold	1.835V	1.88V	1.915V
Open loop detection	0.237V	0.31V	0.387V
Junction operating temperature range	-25°C	–	+125°C
Pb-free lead plating RoHS compliant	–	–	–

## Smart Ballast Controller

### ICB2FL01 G

#### Features

- Able to handle lamp chokes with higher saturation behavior
- Special in-circuit test mode for faster test time
- Excellent dynamic PFC performance enables very low THD across wide load ranges
- Separate adjustable levels of lamp overload and rectifier effect detection
- Adjustment of the preheat time
- No high voltage capacitor required for detection of lamp removal (capacitive mode operation)
- Automatically restarts by surge and inverter overcurrent events
- Skipped preheating when line interruption < 500ms
- Self adapting dead time adjustment of the half bridge driver
- One single restart at fault mode

#### Benefits

- Optimized lamp choke size and reduced BOM costs
- Dramatically reduced time for key tests such as end of life detection, preheat/ignition timeout and pre rung operation modes
- Suitable for dimming and multi-power ballasts
- Enables ballast compatibility with a wider range of lamp types
- Flexible support of both current and voltage mode preheating
- Reduced BOM costs
- Intelligent discrimination between surge & half bridge overcurrent events
- Meets standards for emergency lighting (according to DIN VDE 0108)
- Eases design of multi-power ballasts and reduces EMI
- Enhanced reliability of ballasts

### ICB2FL02 G

The ICB2FL02 G is functionality identical to the ICB2FL01 G with adjustments to certain timings and parameters to further optimize performance in dimming ballasts.

Function	ICB2FL02 G	ICB1FL01 G
Cap load 1 protection	Deactivated	Activated
Suitable for Dimming	Optimized	yes
Max adjustable run frequency	max. 140kHz	max. 120kHz
Adjustable dead time	1.05µs	1.05µs to 2.5µs
Dead time detector level	-50mV	-100mV
Capacitive mode 2 detector level 3	-50mV	-100mV

## ICB2FL03 G

Infineon's latest Smart Ballast Controller ICB2FL03 G in SO-16 offers very similar performance and feature set compared to the well established SO-19 product ICB2FL01 G

	ICB2FL03 G	ICB1FL01 G
Package	SO-16 small body	SO-19 wide body
Driver capability	650V	900V
Lamp connection	single and series	single, series and parallel

## ICB1FL02 G

ICB1FL02 G is Infineon's 1<sup>st</sup> Generation Ballast Controller. As performance, feature set and BOM savings have been greatly improved in Infineon's 2<sup>nd</sup> Generation ICs, it is recommended to use those in new designs.

## LED Driver for General Lighting

### ICL8001G / ICLS8082G

ICL8001G / ICLS8082G are designed for off-line LED lighting applications with high efficiency requirements such as incandescent bulb replacements (40/60/100W) and lamp retrofits. Infineon provides a single stage flyback solution with PFC and dimming functionality. Innovative primary control techniques combined with accurate PWM generation for phase cut dimming enable solutions with significant reduced component count on a single sided driver PCB for smallest form factor.

#### Benefit

- ICL8001G simplifies LED driver implementation at best-in-class BOM costs
- ICLS8082G integrates CoolMOS™ switch

#### Features

- High and stable efficiency over wide operating range
- Optimized for trailing- and leading-edge dimmer
- Precise PWM for primary PFC and dimming control
- Power cell for  $V_{CC}$  pre-charging with constant current
- Built-in digital soft-start
- Foldback correction and cycle-by-cycle peak current limitation
- $V_{CC}$  over-/undervoltage lockout
- Auto restart mode for short circuit protection
- Adjustable latch-off mode for output overvoltage protection

ICL8001G

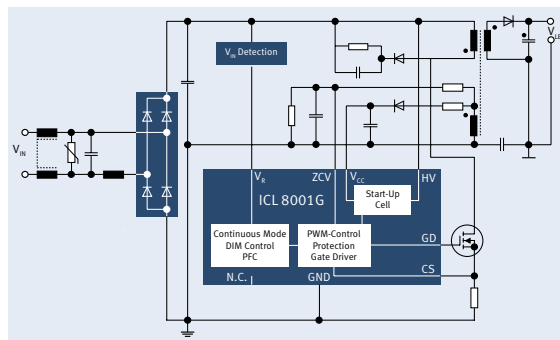

ICLS8082G

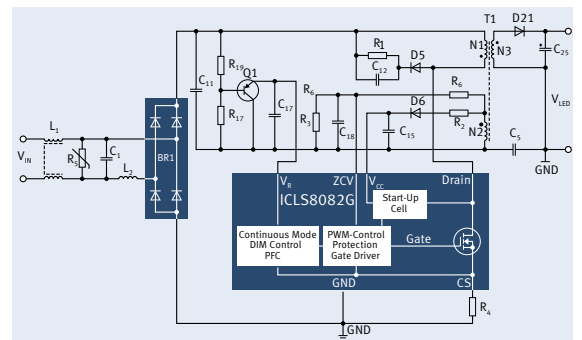

\* in development

# Driver ICs

## 1ED020I12-F

Single channel isolated gate driver

- Basic isolation according to EN60747-5-2, recognized under UL1577
- Fully functional at transient +/- 1420V and static voltages of +/-1200V
- High voltage side status feedback
- 2A sink and source rail-to-rail output
- Max. Tj = 150°C
- Package SO16 300mil
- Protection functions:
  - Desaturation detection
  - Active Miller clamp
  - Under voltage lockout
  - Shut down
  - Watchdog timer

## 1ED020I12-B2\*

Single channel isolated gate driver

- Same functions and features as 1ED020I12-F
- Basic isolation according to EN60747-5-2, recognized under UL1577
- Enhanced desaturation detection with 500µA

## 1ED020I12-F2

Single channel isolated gate driver

- Same functions and features as 1ED020I12-B2
- Functional isolation of 1200V

## 1ED020I12-BT\*

Single channel isolated gate driver

- Same functions and features as 1ED020I12-F
- Basic isolation according to EN60747-5-2, recognized under UL1577
- Adjustable two level turn-off function
- Desaturation detection with 500µA

## 1ED020I12-FT\*

Single channel isolated gate driver

- Same functions and features as 1ED020I12-BT
- Functional isolation of 1200V

## 2ED020I12-F2\*

Dual channel isolated gate driver

- Same functions and features as two times 1ED020I12-F2
- Package SO36 300mil

Typical application 1ED020I12-F

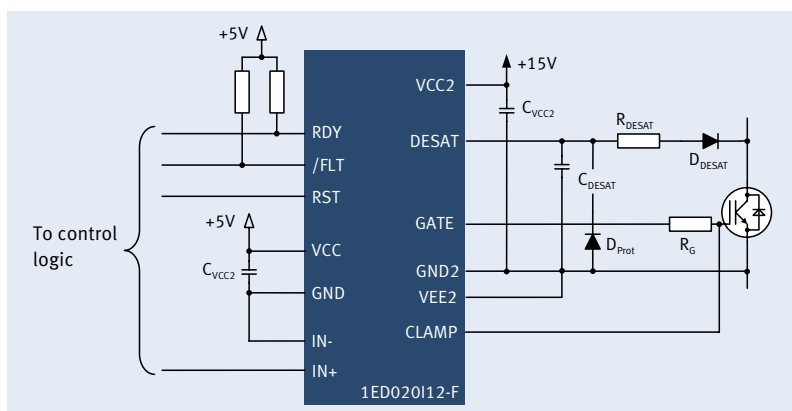

## 2ED020I12-FI

1200V Isolated high side half bridge gate driver

- Galvanic isolation of high side driver
- 2A sink current, 1 A source current
- Fully functional at transient and static voltages of +/-1200V
- Integrated operational amplifier and comparator
- Matched delay times of high side and low side
- Max. Tj = 150°C
- Package SO18 300mil
- Protection function:
  - Hardware input interlocking
  - Under voltage lockout
  - Shut down function

## 2ED020I06-FI

650V isolated high side half bridge gate driver

- Galvanic isolation of high side driver
- 2A sink current, 1 A source current
- Fully functional at transient and static voltages of +/-650V
- Matched delay times of high side and low side
- Max. Tj = 150°C
- Package SO18 300mil
- Protection function:
  - Hardware input interlocking
  - Under voltage lockout

Driver ICs Features / Parameters

Products	Channels / Isolated Channels	Supply Voltage Range Driver	Integrated bootstrap diode	typ. Source / Sink Current
200V	6ED003L02-F	11V - 20V	–	0.17A / 0.38A
	6EDL04N02PR	9V - 20V	✓	0.17A / 0.38A
600V	6ED003L06-F	11V - 20V	–	0.17A / 0.38A
	6EDL04I02NT	11V - 20V	✓	0.17A / 0.38A
	6EDL04I02PT	11V - 20V	✓	0.17A / 0.38A
	6EDL04N02PT	9V - 20V	✓	0.17A / 0.38A
	2ED020I06-FI	11.2V - 20V	–	1A / 2A
1200V	1ED020I12-F	-12V - 0V / 11V - 20V	–	2A / 2A
	1ED020I12-F2 / B2 *	-12V - 0V / 11V - 20V	–	2A / 2A
	1ED020I12-FT * / BT *	-12V - 0V / 11V - 20V	–	2A / 2A
	2ED020I12-FI	11.2V - 20V	–	1A / 2A
	2ED020I12-F2 *	-12V - 0V / 11V - 20V	–	2A / 2A

\* in development

\*1 Fault signal appears L = Latched or T = Temporary latched, adjustable mono flop

\*2 RDY Signal shows driver has passed UVLO at input and output and communication is ready

For automotive qualified parts please see [www.infineon.com/eicedriver](http://www.infineon.com/eicedriver)

## 6ED family – 2nd generation

200V and 600V 3-phase gate driver

- Ultra fast integrated bootstrap diode
- Fully functional at neg. transient voltages down to -50V (500ns)
- Programmable restart after over current protection
- Shut down of all outputs in case of UVLO, OCP
- Package SO28 300mil (600V) and
- package TSSOP28 (200V)
- Protection functions:
  - Over current protection (OCP)
  - Hard ware input interlocking
  - Under voltage lockout (UVLO)
  - Fixed hard ware dead time of high side and low side
  - Enable function
  - Pin compatible variants of first generation available

Typical application 6ED003L06-F

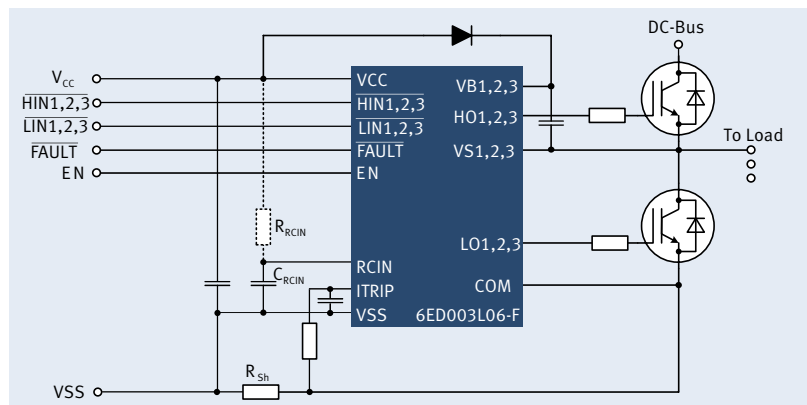

typ. Application PWM Frequency up to	Logic Supply	Seperated SGND / PGND	Input Logic	Interlock	typ. Dead Time	OCP / DESAT	Fault *1	EN / SD / RST	RDY *2	Two Level Turn Off
20kHz	13V - 17.5V	✓	neg.	✓	310 ns	OCP	T	✓	–	–
20kHz	10V - 17.5V	✓	pos.	✓	310 ns	OCP	T	✓	–	–
20kHz	13V - 17.5V	✓	neg.	✓	310 ns	OCP	T	✓	✓	–
20kHz	13V - 17.5V	✓	neg.	✓	310 ns	OCP	T	✓	✓	–
20kHz	13V - 17.5V	✓	pos.	✓	310 ns	OCP	T	✓	✓	–
20kHz	10V - 17.5V	✓	pos.	✓	310 ns	OCP	T	✓	–	–
200kHz	14V - 18V	✓	pos.	✓	0 ns	–	–	✓	✓	–
100kHz	5V	✓	pos. / neg.	–	–	DESAT	L	✓	✓	–
100kHz	5V	✓	pos. / neg.	–	–	DESAT	L	✓	✓	–
100kHz	5V	✓	pos. / neg.	–	–	DESAT	L	✓	✓	✓
200kHz	14V - 18V	✓	pos.	✓	0 ns	OCP	–	✓	–	–
100kHz	5V	✓	pos. / neg.	–	–	DESAT	L	✓	✓	–

# Isolated Interfaces

## ISOFACE™ Galvanically Isolated Digital Input Interface ICs for Automation

ISO1I811T

ISO1I813T

### 8-Channel Isolated and Fully Integrated Digital Input Interface IC:

- Fully integrated system solution for
  - Galvanic isolation
  - Signal processing
  - $\mu$ C interfacing

#### Features

- 8 channel digital input (IEC Type 1/2/3)
- Integrated galvanic isolation (500V)
- Up to 500kHz sampling speed
- Programmable deglitching input filters
  - 9 different settings
  - Individually per channel
- Diagnostic feedback
  - Wire-break, individually per channel
  - Supply undervoltage

#### Benefits

- Compact system solution
- No need for opto-couplers
  - 75% less PCB area
  - 30% lower eBOM
- High-precision applications
- High-speed applications
- Superior EMI robustness through application-specific settings
- Excellent maintenance support

### Key Differences

Type	Max. input signal frequency	Filter time setting	Number of different filter time settings	Diagnostics	SP-Number
ISO1I811T	125kHz	common for all channels	4	--	SP000876494
ISO1I813T	500kHz	individual per channel	9	wire-break, channel-specific	SP000876504

## ISOFACE™ Galvanically Isolated Switches for Automation

ISO1H811G / ISO1H812G  
ISO1H815G / ISO1H816G

### 8-Channel Isolated High-Side Switch for Industrial Applications:

- Fully integrated system solution for
  - Galvanic isolation
  - Logic
  - Driver

#### Features

- 8 channels:
  - 0.6 or 1.2A, each
  - Parallel outputs (optional)
- Integrated galvanic isolation (500V)
- Inductive load switching
- Integrated short-circuit protection
- Diagnostic feedback:
  - Over-temperature
  - Over-load
  - Under-voltage
- $\mu$ Controller interface:
  - 3.3V and 5V
  - Parallel and serial

#### Benefits

- Compact system solution
- Supports wide range of loads
- No need for opto-couplers
  - 50% less PCB area
  - 30% lower eBOM
- Fail save
- System status feedback
- Maintenance support
- Directly interfacing with all  $\mu$ Processors and  $\mu$ Controllers

### Key Differences

Type	Load Current	$\mu$ C Interface	SP-Number
ISO1H811G	0,7A	parallel	SP000413798
ISO1H812G	0,7A	serial	SP000413800
ISO1H815G	1,2A	parallel	SP000555576
ISO1H816G	1,2A	serial	SP000555578

# Power Audio

## Digital Input Class-D Power Audio Amplifier with DSP

### SAB2402 / SAB2403

The SAB 2402 / SAB 2403 ICs are high performance energy efficient digital and analog input high dynamic range open loop Class-D speaker amplifiers. Phase-neutral 512TAP FIR digital Filter & Signal Processing features are included for optimizing sound in slim – form factor driven Speakers like in Flat Panel TVs & Active Speaker designs.

The digital input interfaces S/PDIF for long wires or Optical (TOS-Link) Input as well as the I2S Chip to Chip interface take the incoming PCM Audio data with up to 96kHz (192kHz) via a jitter removing self adopting variable sample rate converter to the 24 Bit wide digital audio processing chain. After the sound and volume control stage the monolithic integrated output power stages work with supply voltages from 10V to 27V ;

- heatsinkless up to 2 x 25W<sub>RMS</sub> or 1 x 50 W<sub>RMS</sub> or 2 x 10W<sub>RMS</sub> & 1 x 20W<sub>RMS</sub> on RL 4 or 8 Ω
- with heatsink up to 2 x 50W<sub>RMS</sub> or 1 x 100W<sub>RMS</sub> or 2 x 15W<sub>RMS</sub> & 1 x 50W<sub>RMS</sub> on RL 4 or 8 Ω

A unique 2.1 Stereo Subwoofer Mode can be implemented with one device on the same stereo PCB footprint and with no additional discrete components. This allows to save one amplifier device. A feature commonly requested in Flat Panel TVs & Mini-Combo Active Speaker Audio Appliances.

The high resolution 512TAP FIR Filters allow parametric frequency equalization and/or digital frequency bridge filters without adding non-linearities or phase distortions. The device is available in a thermal enhanced 10 x 10 mm VQFN 68 pin package for heatsinkless operation.

#### Product Highlights

- Reduced System BOM
  - BTL differential outputs, no coupling C
  - Footprint compatible 2.1 Subwoofer mode
- High Quality Audio typ. 100dB SNR
- Low THD less than 0,3% THD at max 25W; 0,03% THD at 2.5 W @ 1kHz
- Digital Input SPDIF + I2S with 32kHz up to 96 kHz (\*I2S up to 192kHz)
- 3x 512tap / 6x 256tap FIR filter bank for slim speaker equalization
  - Comes with simple fast PC Tool for speaker tuning & DSP target filter generation
- Easy to use I2C Command Interface
- Up to 8 GPIOs

#### Target Markets

- Flat Panel - TVs
- Active Speakers, Soundbars
- Mini Combo & Portable Electronics
- Digital PCM and MPEG Media Streaming
- Multichannel Audio Consumer Speakers
- HD Audio & DSP Driven Consumer Devices (Blue Ray/DVD)
- AV/DVD Receivers and AV Amplifiers

#### Development Support

- PCB Reference Designs (EMI approved)
- API Command Interface
- PC SW Tool to create Filter Functions
- Evaluation Boards
- Documentation & Application Notes

### SAB 240x True Monolithic Integration + Power

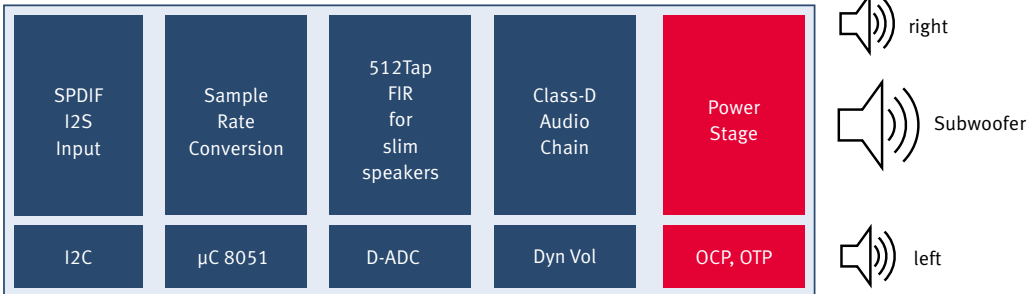

### LCD-TV Applications Options Power Supply PCB

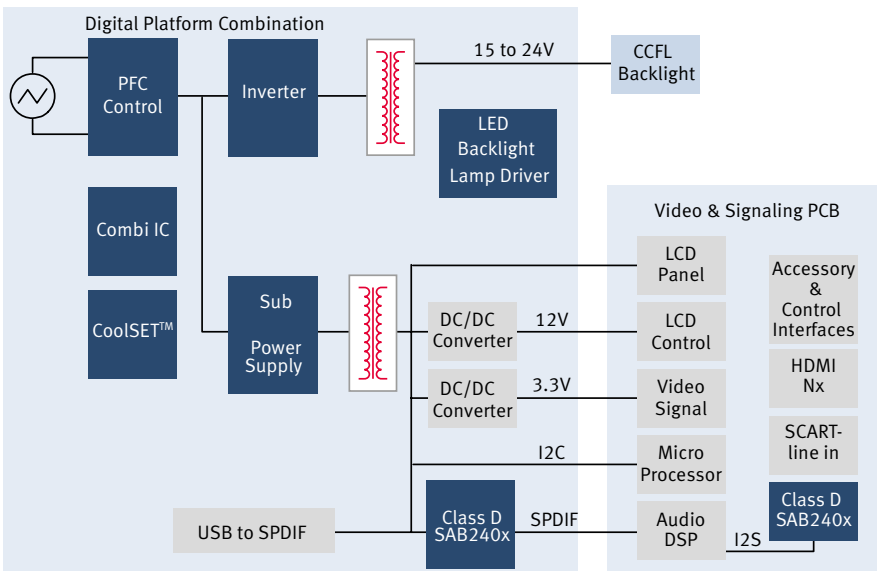

### Active Speaker Application

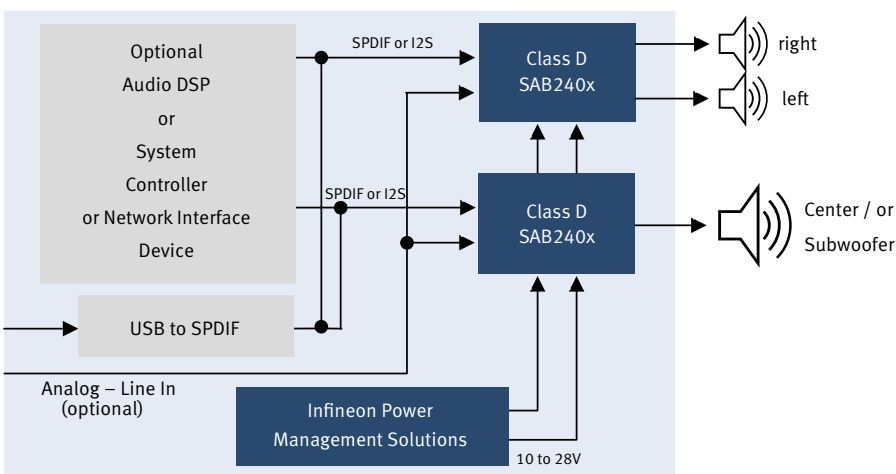

# Naming System

## Lighting ICs

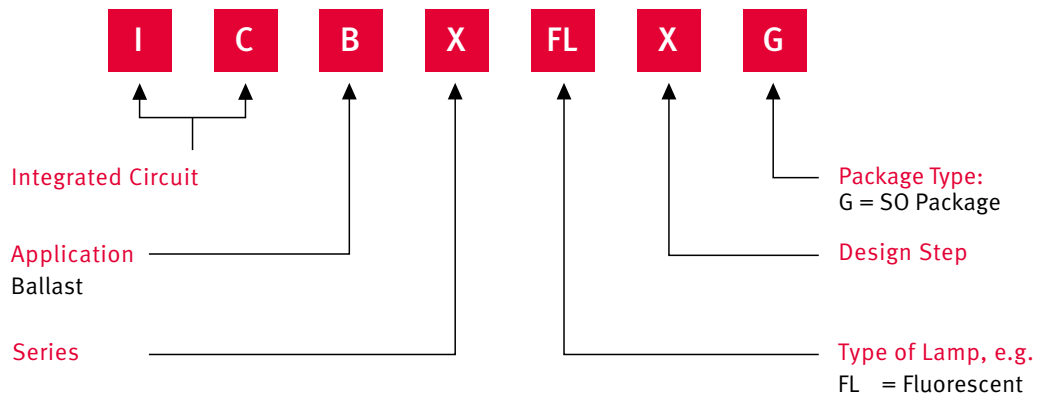

## Isolated Interfaces (ISOFACE™)

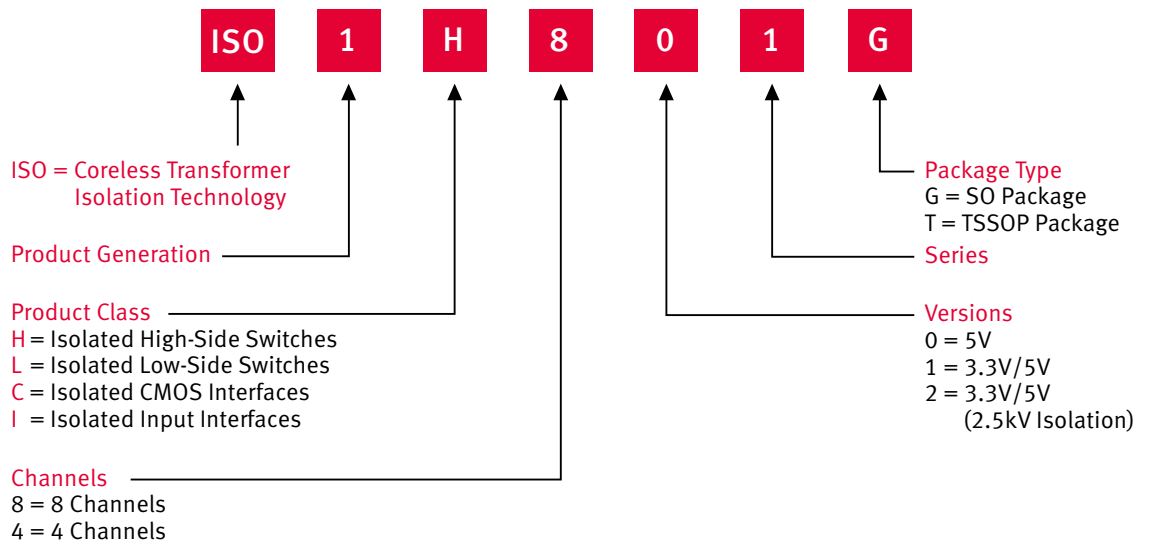

## Driver ICs (EiceDRIVER™)

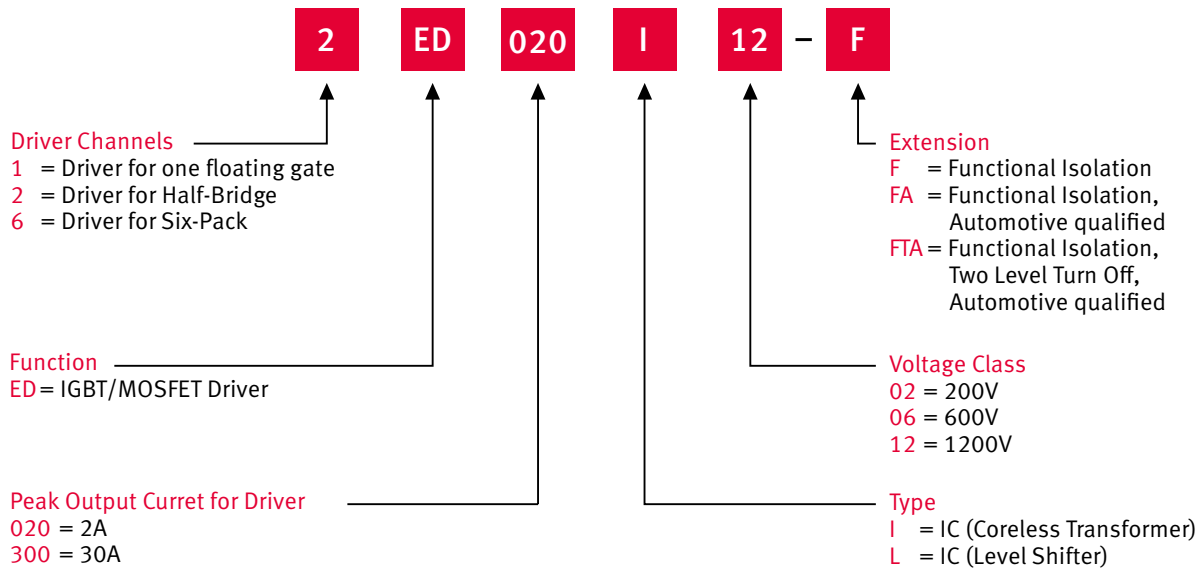

# Packages

## Top and bottom side cooling of SMD devices

For LV MOSFETs different SMD packages like SuperSO8 and CanPAK™ are available. If the cooling system is designed for main heatflow to the PCB both packages will show similar thermal performance. If the main heat flow is to the top side the CanPAK™ is the better choice since the thermal resistance to the top side is lower ( $R_{th\_top\_CanPAK} \sim 1 \text{ K/W}$ ,  $R_{th\_top\_SuperSO8} \sim 20 \text{ K/W}$ )

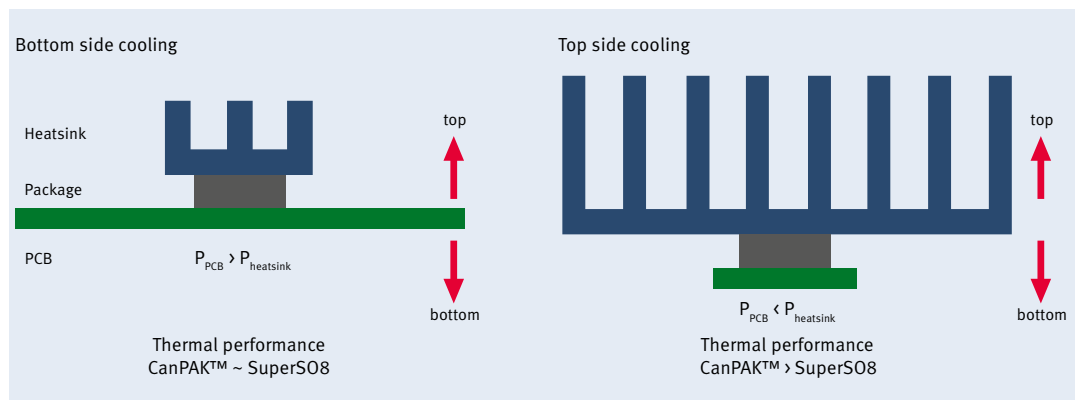

Example: High performance Server  
(PCB: 8 layer, 70  $\mu\text{m}$ )



Example: Motherboard (PCB 4 layer, 35  $\mu\text{m}$ )  
with high performance heatsink



## ThinPAK new leadless SMD package for high voltage MOSFETs

- The new package features a very small footprint of only 64 mm<sup>2</sup> (vs. 150 mm<sup>2</sup> for the D<sup>2</sup>PAK) and a very low profile with only 1 mm height (vs. 4.4 mm for the D<sup>2</sup>PAK). This significantly smaller package size with its benchmark low parasitic inductances can be used as a new and effective way to decrease system solution size in power-density driven systems
- A well designed thermal system is required to achieve high power handling capability. The recommended design is a thin PCB with many vias and a heatsink attached to the backside of the PCB. A high number of thermal vias is needed to reduce the thermal conduction resistance through the board

60 % footprint reduction - 80 % height reduction

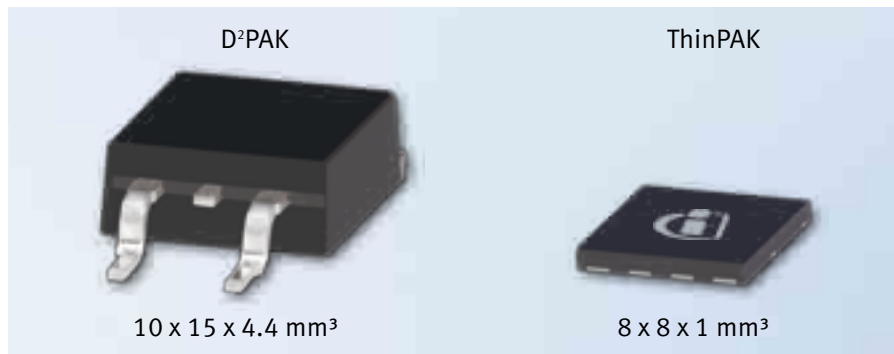

Thermal cooling system for ThinPAK 8x8

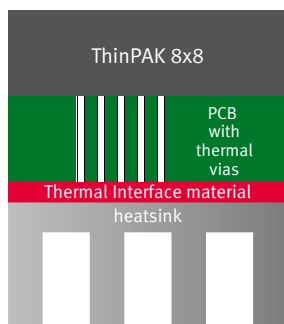

## New package TO-247HC

The TO-247HC is a package with an increased creepage distance (potential replacement for TO-247). If the TO-247 doesn't comply to the creepage distance requirements the customer can choose the TO-247-HC without taking any measures to improve the package isolation (e.g.: potting)

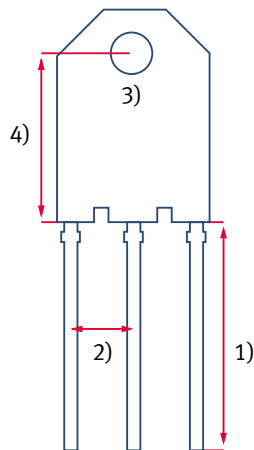

- 1) pin length 20mm like TO-247
- 2) pin width / thickness 1.2mm / 0.5mm is TO-247 / TO3P-compatible  
6.35mm creepage distance of leads at package body
- 3) isolated screw hole like TO-247 / TO3P
- 4) 14.8mm nominal distance screw hole to pin out plane is the same as at TO-247 / TO3P

## New IGBT technology RCD allows highest power density with small SMD packages

The new IGBT RCD technology in combination with an efficient cooling system allows to use small SMD packages which enable to build compact systems with increased power density.

In order to improve the heat dissipation, thermal vias are integrated in the PCB under the device case which results in a low thermal resistance to the opposite side of the PCB. A heatsink complements the cooling system. Isolation to the heatsink is realized with a thermal foil. With this cooling system power dissipation up to 7 to 10 W / IGBT is achievable which corresponds to ~ 2 kW application systems.

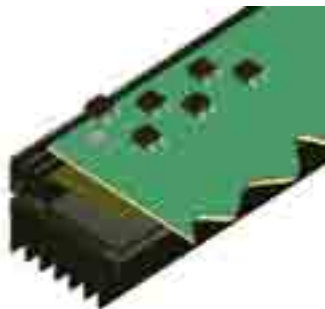

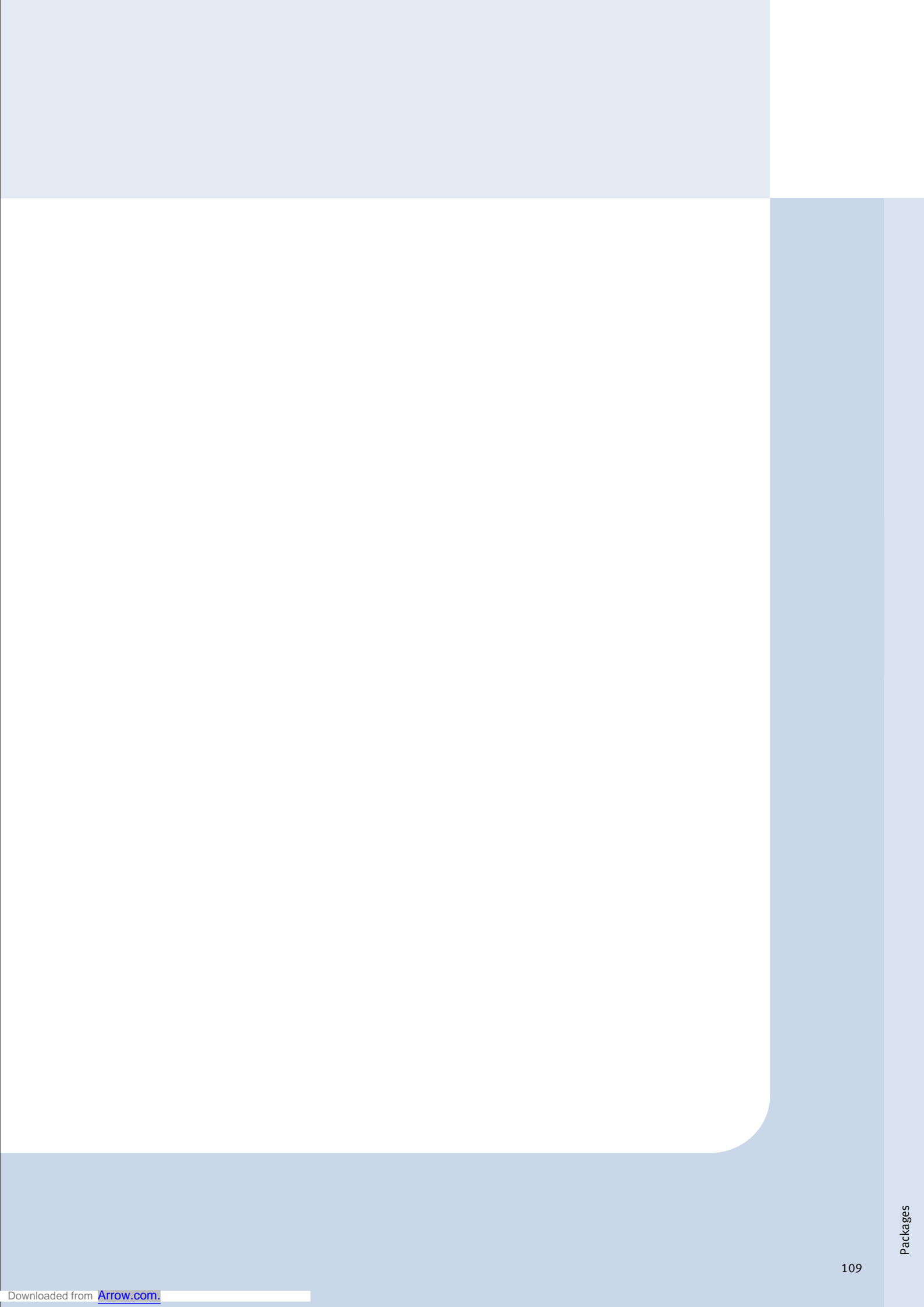

Package (JEITA-code)	
X	L x W x H
PIN-Count	
All Dimensions in mm	

# Packages

IPAK (TO-251)		IPAK SL (TO-251 SL)		I <sup>2</sup> PAK (TO-262)		TO-220 real 2pin		TO-220 2pin		TO-220 3pin	
3	15.5 x 6.5 x 2.3	3	10.7 x 6.5 x 2.3	3	25.1 x 10 x 4.4	2	29.15 x 10.0 x 4.4	2	29.1 x 9.9 x 4.4	3	29.15 x 10.0 x 4.4
TO-220 FullIPAK		TO-220-6-46		TO-220-6-47		TO-247		TO-247HC		DPAK (TO-252)	
3	29.6 x 10.5 x 4.7	6	21.7 x 9.9 x 4.4	6	26.1 x 9.9 x 4.4	3	40.15 x 15.9 x 5.0	3	37.6 x 13.6 x 4.5	3	9.9 x 6.5 x 2.3
Reverse DPAK (Rev. TO-252)		DPAK 5pin (TO-252 5pin)		D <sup>2</sup> PAK (TO-263)		D <sup>2</sup> PAK 7pin (TO-263 7pin)		SO-8/SO-8 dual		SO-16/12	
3	9.7 x 6.6 x 2.34	5	9.9 x 6.5 x 2.3	3	15.0 x 10.0 x 4.4	7	15.0 x 10.0 x 4.4	8	5.0 x 6.0 x 1.75	12	10.0 x 6.0 x 1.75
SO-14		SO-16		SO-18		SO-19		SO-20		SC59	
14	8.75 x 6.0 x 1.75	16	10.0 x 6.0 x 1.75	18	12.8 x 10.3 x 2.65	19	12.8 x 10.3 x 2.65	20	12.8 x 10.3 x 2.65	3	3.0 x 2.8 x 1.1
SOT-23		SOT-89		SOT-223		SOT-323		SOT-363		TSOP-6	
3	2.9 x 2.4 x 1.0	3	4.5 x 4.0 x 1.5	4	6.5 x 7.0 x 1.6	3	2.0 x 2.1 x 0.9	6	2.0 x 2.1 x 0.9	6	2.9 x 2.5 x 1.1
S308		WISON (PowerStage 3x3)		SuperSO8		SuperSO8 dual		VSON (ThinPAK)		CanPAK™ S-Size	
8	3.3 x 3.3 x 1.0	8	3.0 x 3.0 x 0.8	8	5.15 x 6.15 x 1.0	8	5.15 x 6.15 x 1.0	4	8.0 x 8.0 x 1.0	6	4.8 x 3.8 x 0.65
CanPAK™ M-Size		TDSON-10		DIP-7		DIP-8		DIP-14		DIP-20	
7	6.3 x 4.9 x 0.65	10	3.0 x 3.0 x 0.9	7	9.52 x 8.9 x 4.37	8	9.52 x 8.9 x 4.37	14	19.5 x 8.9 x 4.37	20	24.6 x 9.9 x 4.2
TSSOP-48		DSO-36		IQFN-40		TSSOP-28		DSO-28		VQFN-68	
48	12.5 x 6.1 x 1.1	36	15.9 x 11.0 x 3.5	40	6.0 x 6.0 x 0.8	28	9.7 x 6.4 x 1.2	28	18.1 x 10.3 x 2.65	68	10.0 x 10.0 x 0.9

All products are available in green  
(RoHS compliant).



# TO-251

## Package Outline

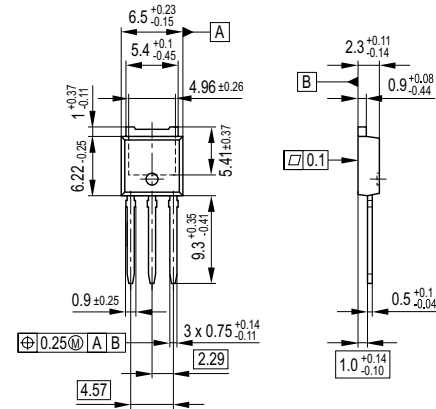

All metal surfaces tin plated, except area of cut.

## Marking Layout

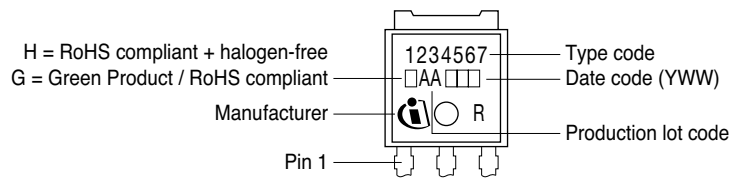

## Packing

Pieces/Tube: 75

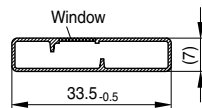

All dimensions in mm

# TO-251-3

## Package Outline

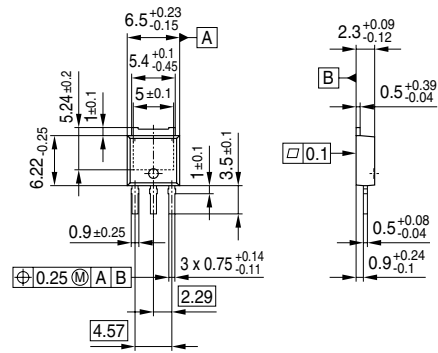

All metal surfaces tin plated, except area of cut.

## Marking Layout

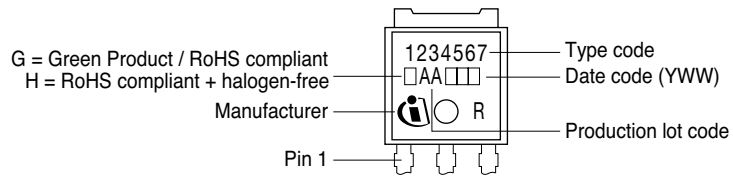

## Packing

Pieces/Tube: 75

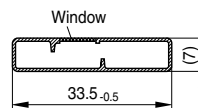

All dimensions in mm

# DPAK

## Package Outline

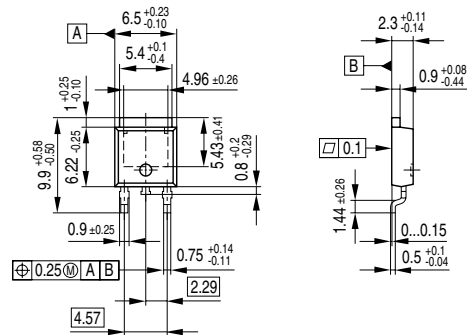

## Foot Print

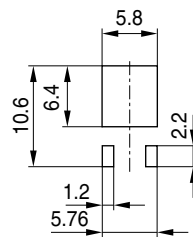

## Marking Layout

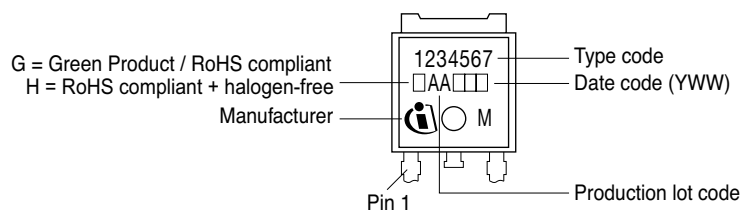

## Packing

Reel ø330mm = 2.500 Pieces/Reel

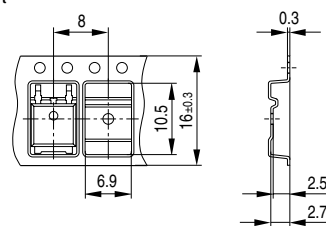

All dimensions in mm

# Reverse DPAK

## Package Outline

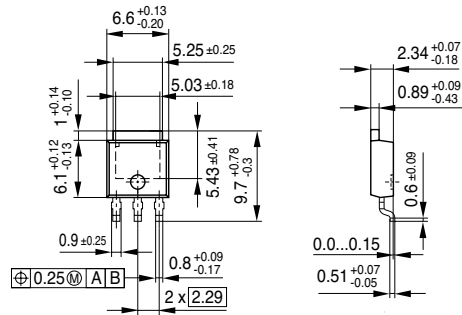

## Foot Print

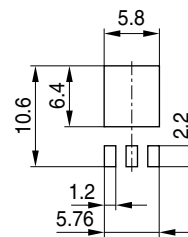

## Marking Layout

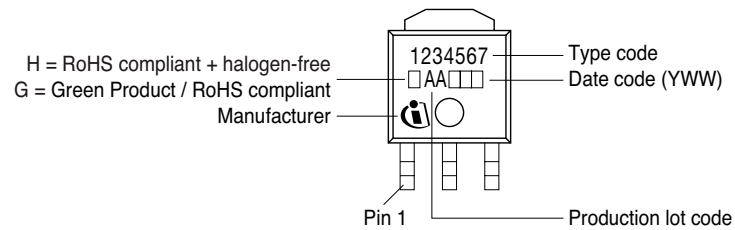

## Packing

Reel  $\varnothing 330\text{mm}$  = 2.500 Pieces/Reel

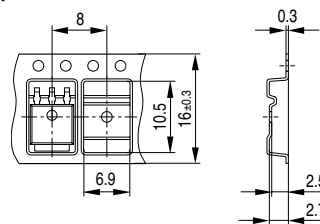

All dimensions in mm

# DPAK 5pin

## Package Outline

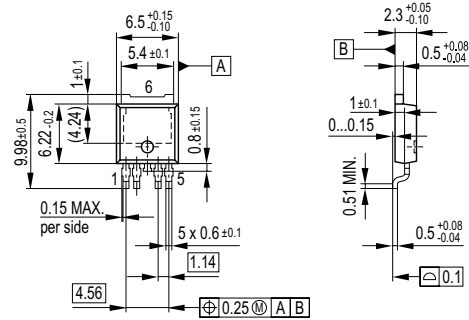

## Foot Print

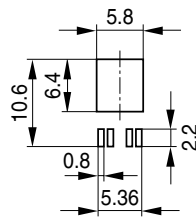

## Marking Layout

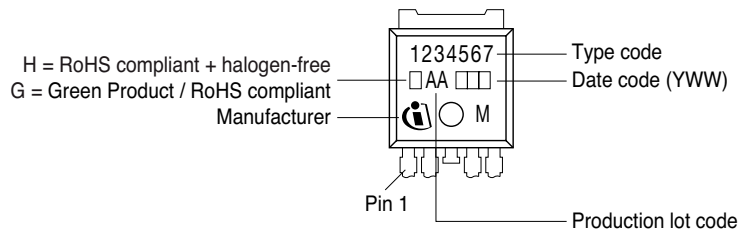

## Packing

Reel  $\varnothing 330\text{mm}$  = 2.500 Pieces/Reel

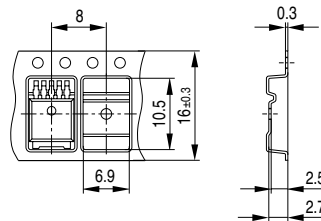

All dimensions in mm

# TO-220 2pin

## Package Outline

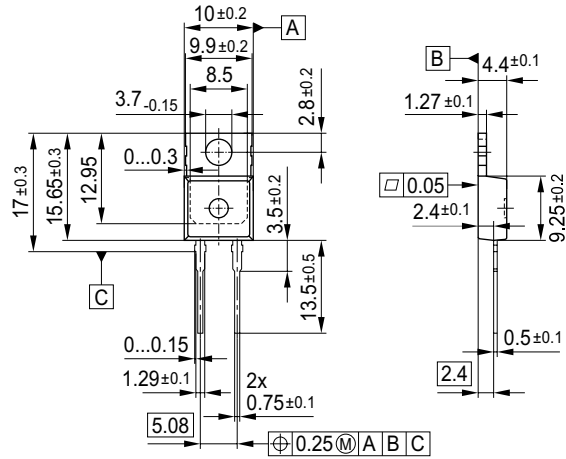

## Marking Layout

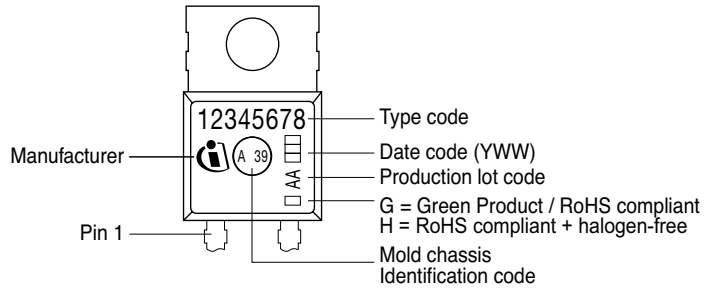

## Packing

Pieces/Tube: 50

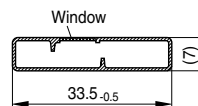

All dimensions in mm

# TO-220 3pin

## Package Outline

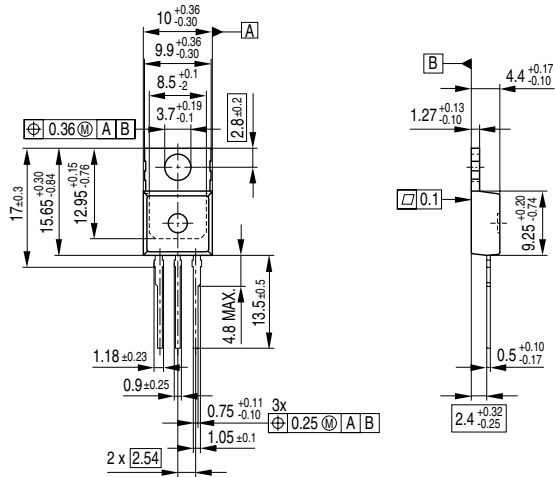

## Marking Layout

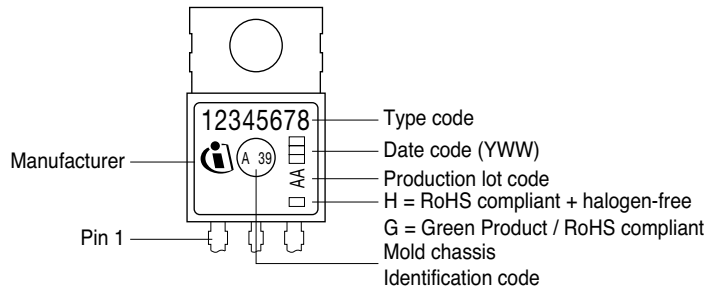

## Packing

Pieces/Tube: 50

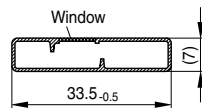

All dimensions in mm

# TO-220 FullPAK

## Package Outline

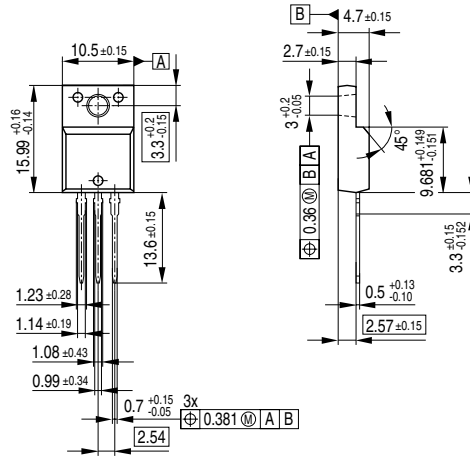

## Marking Layout

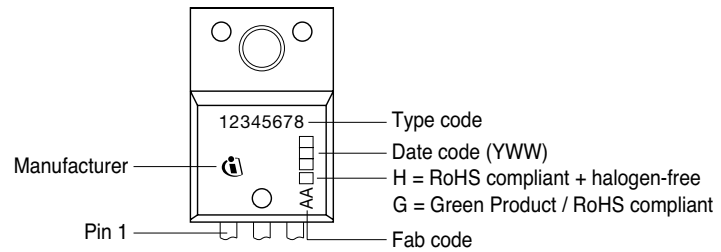

## Packing

Pieces/Tube: 25

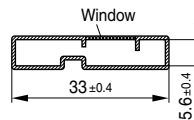

All dimensions in mm

# TO-220-6-46

## Package Outline

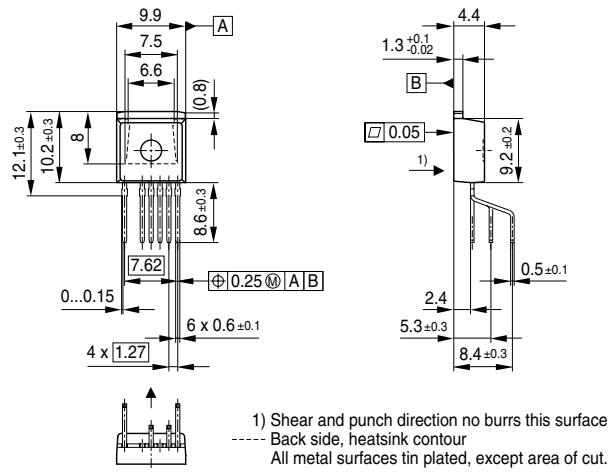

## Marking Layout

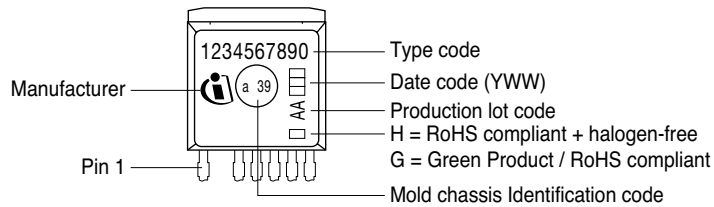

## Packing

Pieces/Tube: 50

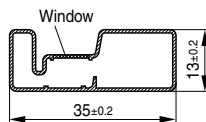

All dimensions in mm

# TO-220-6-47

## Package Outline

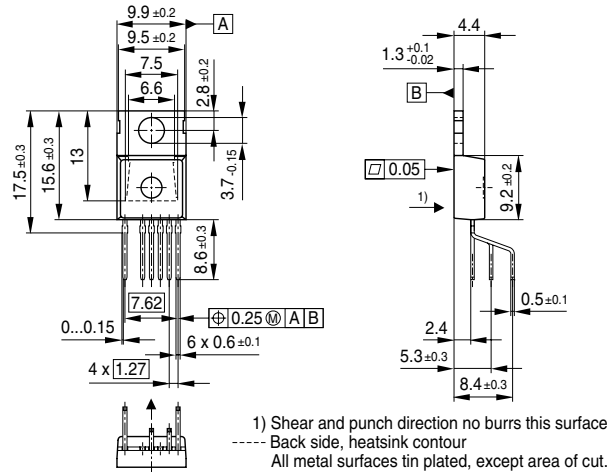

## Marking Layout

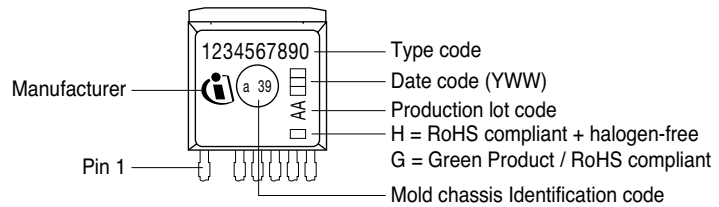

## Packing

Pieces/Tube: 50

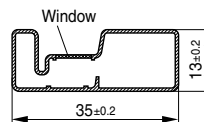

All dimensions in mm

# TO-247

## Package Outline

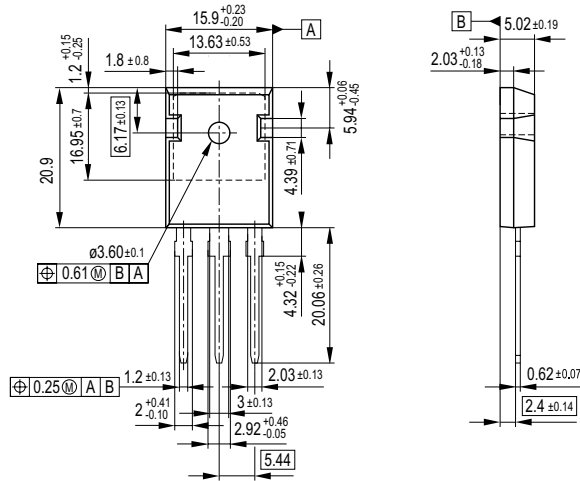

## Marking Layout

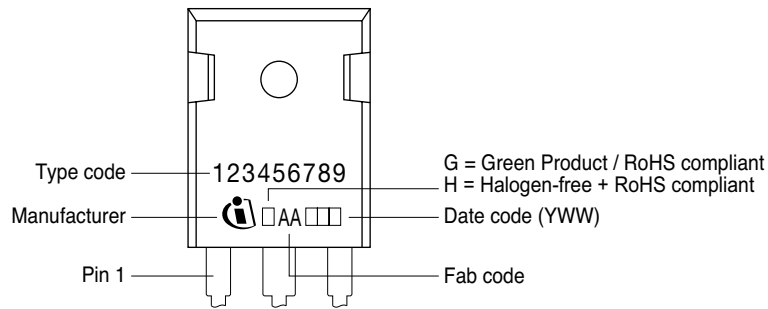

## Packing

Pieces/Tube: 25

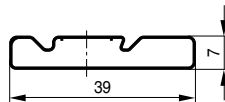

All dimensions in mm

# I<sup>2</sup>PAK

## Package Outline

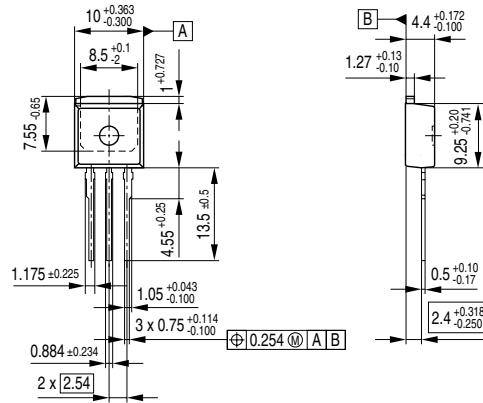

All metal surfaces tin plated, except area of cut.

## Marking Layout

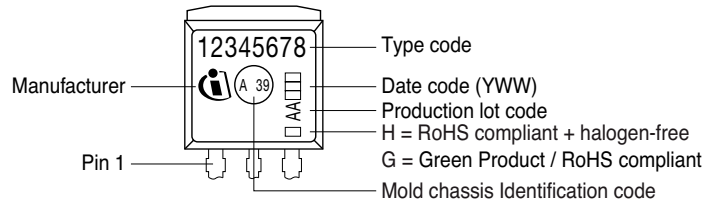

## Packing

Pieces/Tube: 50

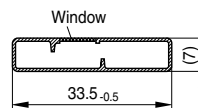

All dimensions in mm

# D<sup>2</sup>PAK

## Package Outline

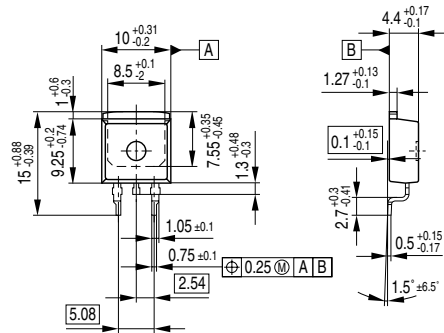

## Foot Print

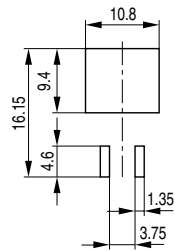

## Marking Layout

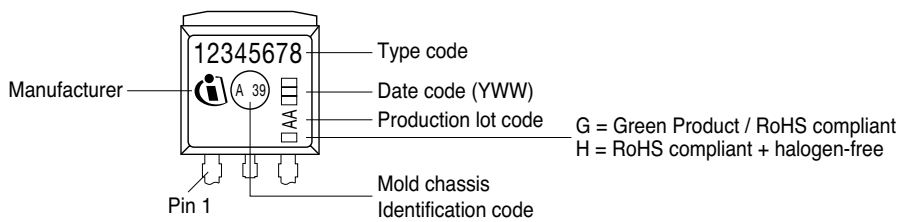

## Packing

Reel ø330mm = 1.000 Pieces/Reel

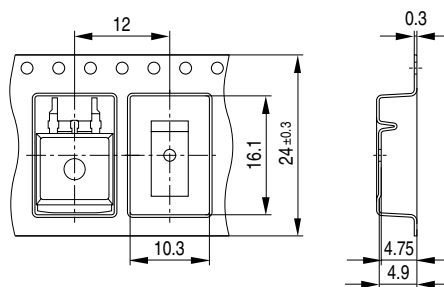

All dimensions in mm

# D<sup>2</sup>PAK 7pin

## Package Outline

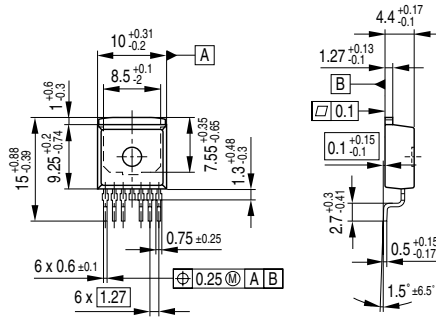

## Foot Print

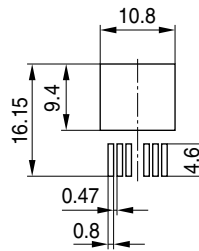

## Marking Layout

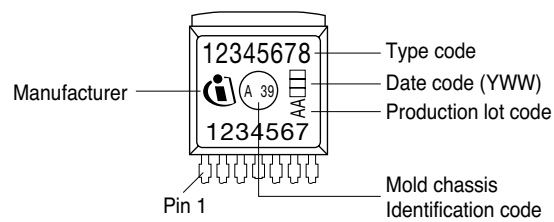

## Packing

Reel  $\varnothing 330\text{mm}$  = 1.000 Pieces/Reel

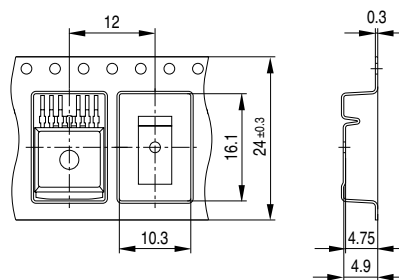

All dimensions in mm

# TO-247HC

## Package Outline

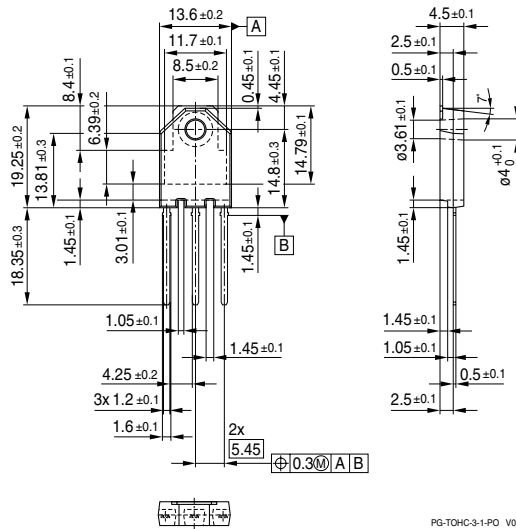

## Marking Layout

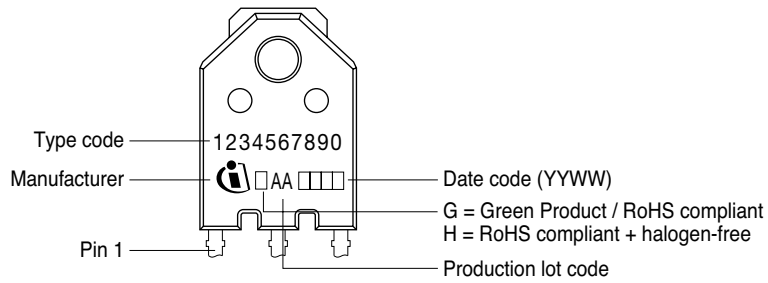

## Packing

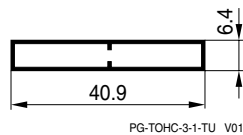

All dimensions in mm

# SO-8

## Package Outline

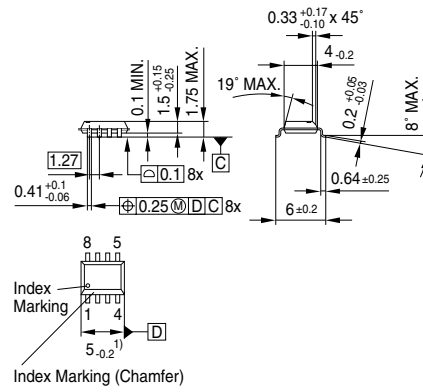

## Foot Print

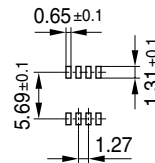

## Marking Layout

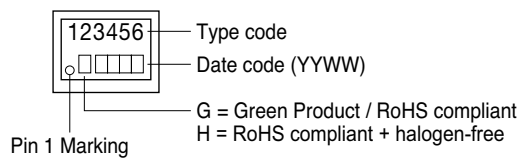

## Packing

Reel ø330mm = 2.500 Pieces/Reel

Pieces/Tube: 100

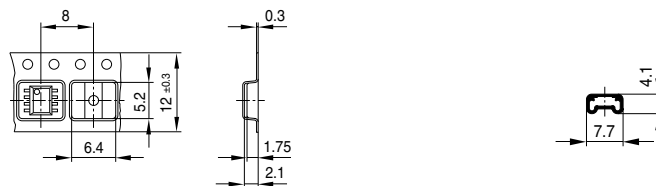

All dimensions in mm

# SO-16/12

## Package Outline

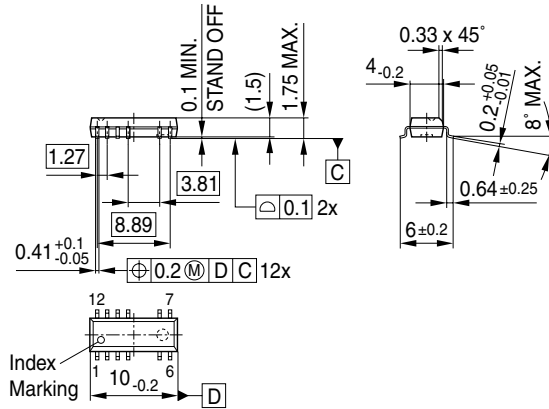

## Foot Print

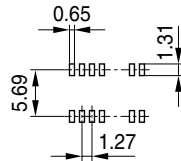

## Marking Layout

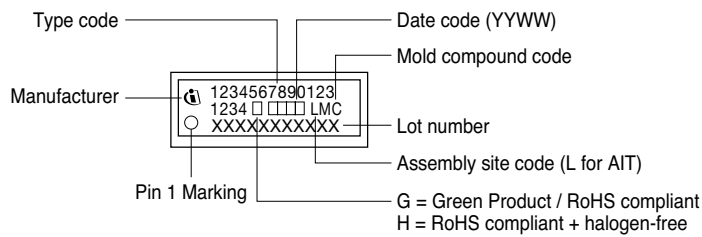

## Packing

Reel ø330mm = 2.500 Pieces/Reel

Pieces/Tube: 50

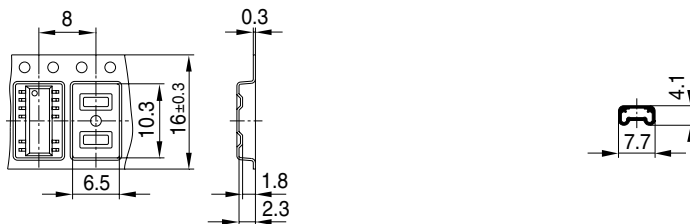

All dimensions in mm

# SO-14

## Package Outline

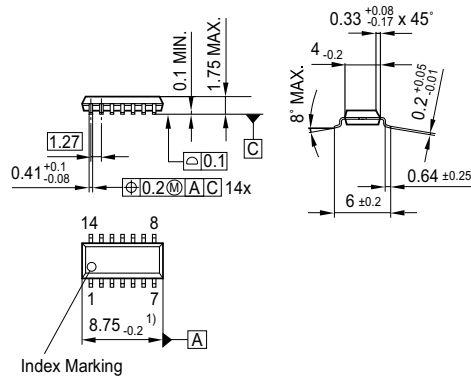

## Foot Print

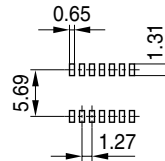

## Marking Layout

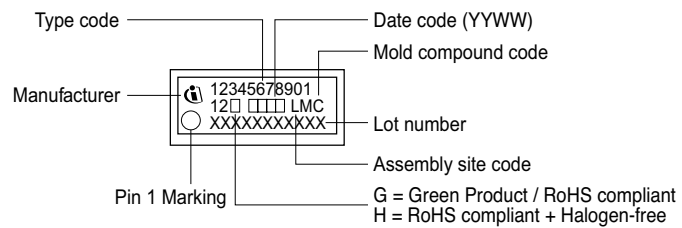

## Packing

Reel  $\varnothing 330\text{mm}$  = 2.500 Pieces/Reel

Pieces/Tube: 50

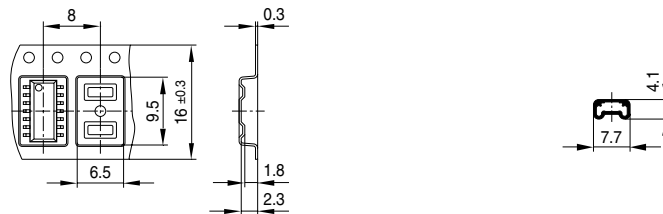

All dimensions in mm

# SO-16/12

## Package Outline

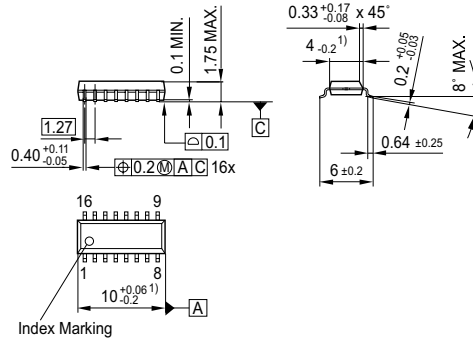

## Foot Print

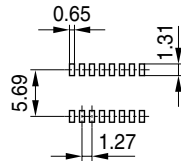

## Marking Layout

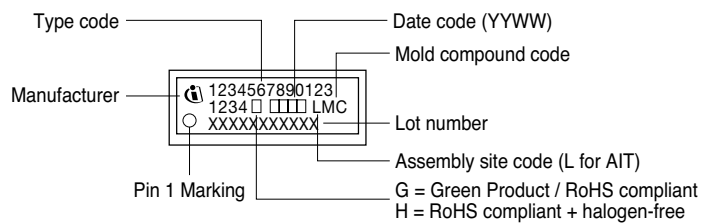

## Packing

Reel  $\varnothing 330$ mm = 2.500 Pieces/Reel

Pieces/Tube: 50

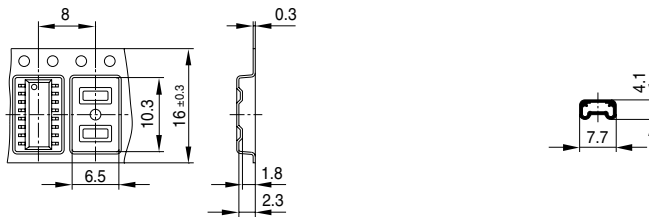

All dimensions in mm

# SO-18

## Package Outline

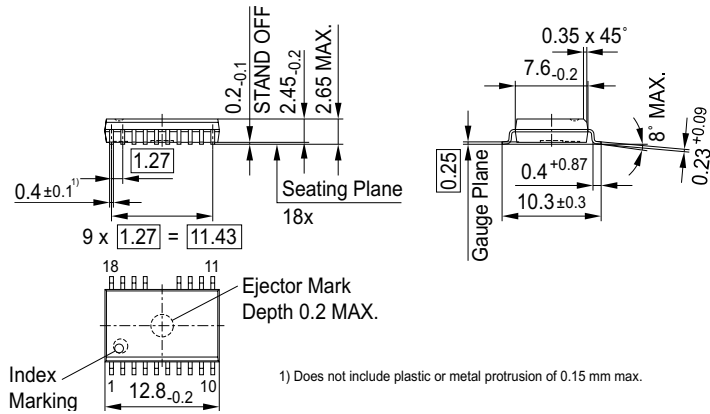

## Foot Print

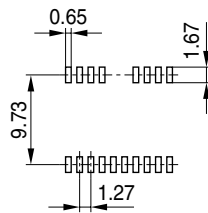

## Marking Layout

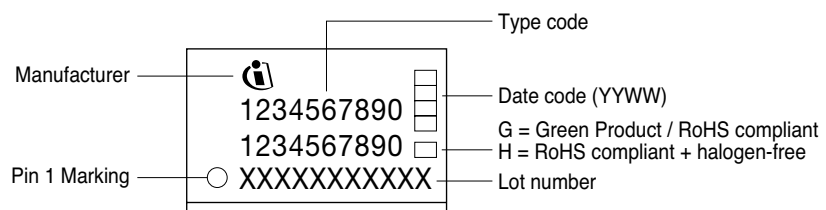

## Packing

Reel ø330mm = 1.000 Pieces/Reel

Pieces/Tube: 39

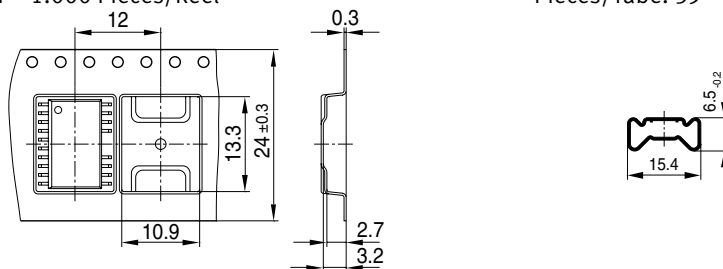

All dimensions in mm

# SO-19

## Package Outline

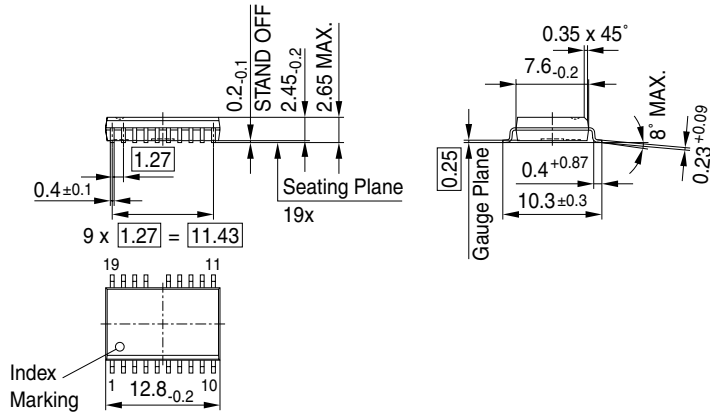

## Foot Print

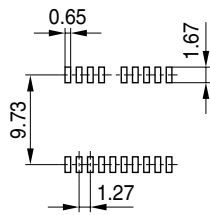

## Marking Layout

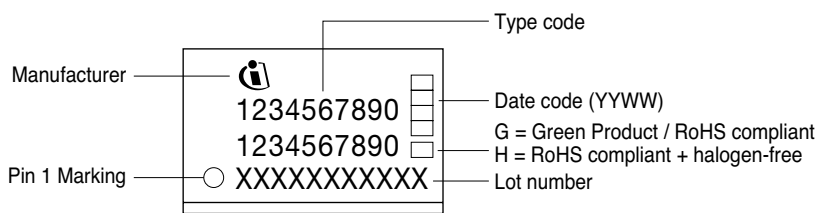

## Packing

Reel ø330mm = 1.000 Pieces/Reel

Pieces/Tube: 39

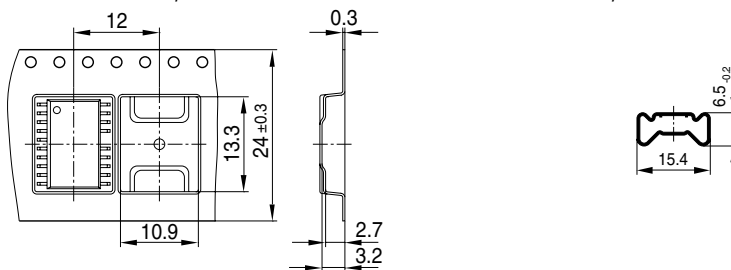

All dimensions in mm

# SO-20

## Package Outline

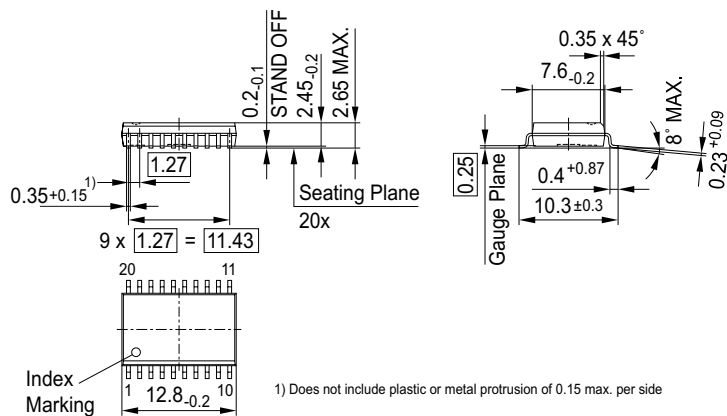

## Foot Print

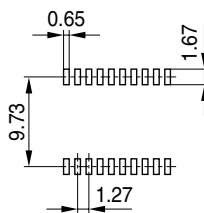

## Marking Layout

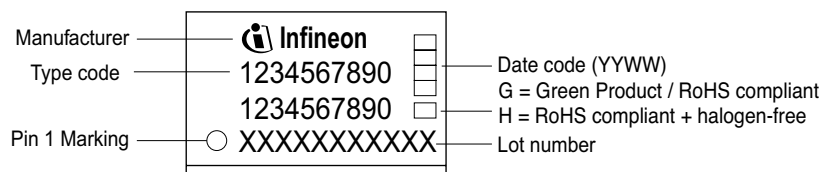

## Packing

Reel ø330mm = 1.000 Pieces/Reel

Pieces/Tube: 39

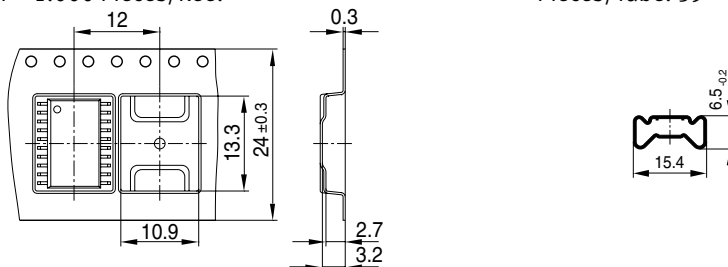

All dimensions in mm

# SC59

## Package Outline

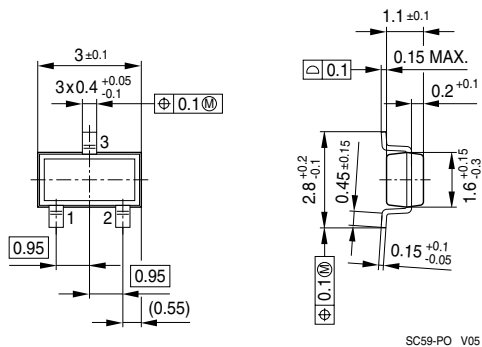

## Foot Print

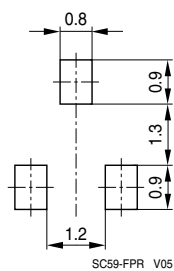

## Marking Layout

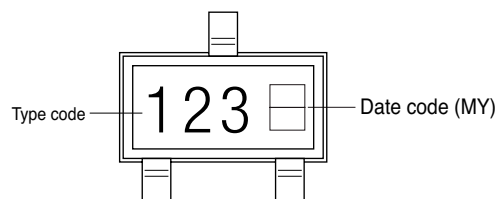

## Packing

Reel  $\phi 180\text{mm}$  = 3.000 Pieces/Reel  
 Reel  $\phi 330\text{mm}$  = 10.000 Pieces/Reel

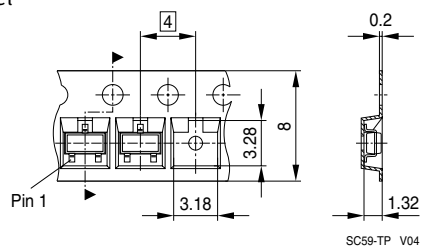

All dimensions in mm

# SOT-23

## Package Outline

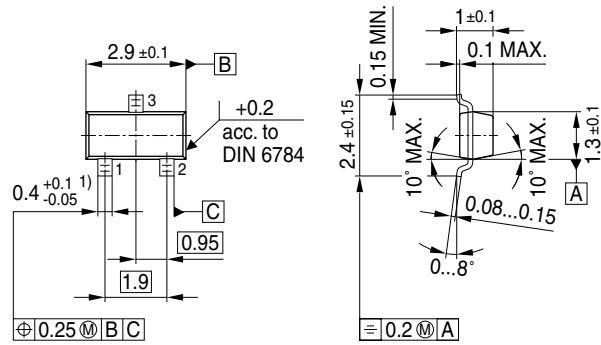

1) Lead width can be 0.6 max. in dambar area

## Foot Print

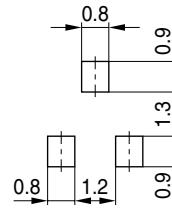

## Marking Layout

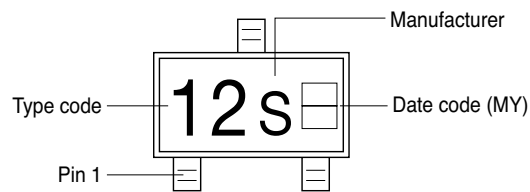

## Packing

Reel  $\varnothing 180$ mm = 3.000 Pieces/Reel

Reel  $\varnothing 330$ mm = 10.000 Pieces/Reel

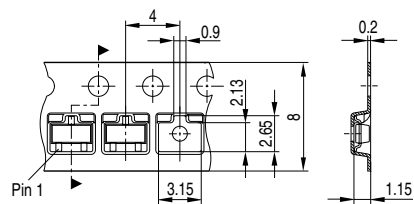

All dimensions in mm

# SOT-89

## Package Outline

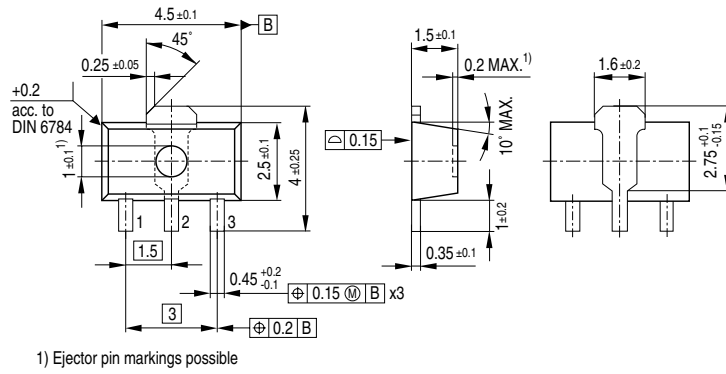

## Foot Print

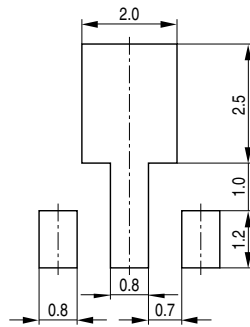

## Marking Layout

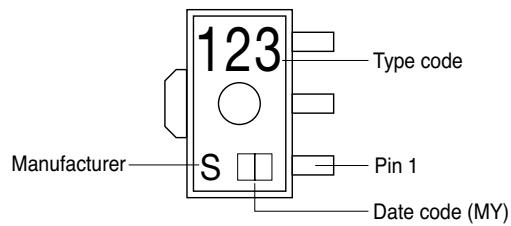

## Packing

Reel  $\varnothing 180\text{mm}$  = 1.000 Pieces/Reel

Reel  $\varnothing 330\text{mm}$  = 4.000 Pieces/Reel

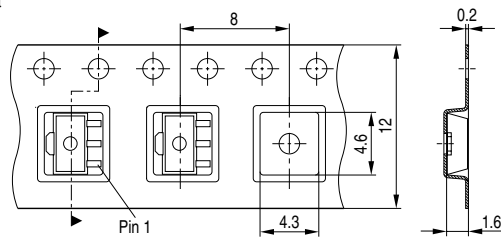

All dimensions in mm

# SOT-223

## Package Outline

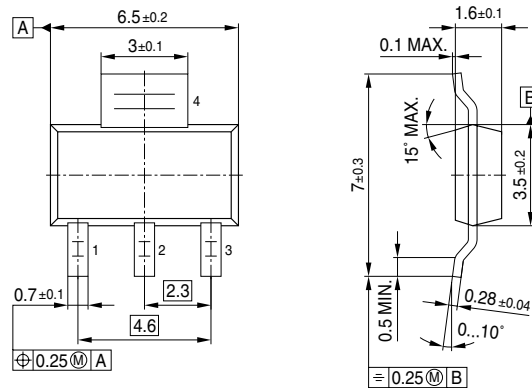

## Foot Print

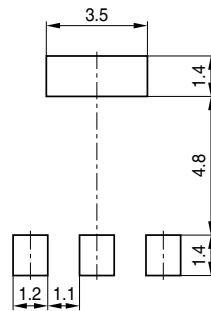

## Marking Layout

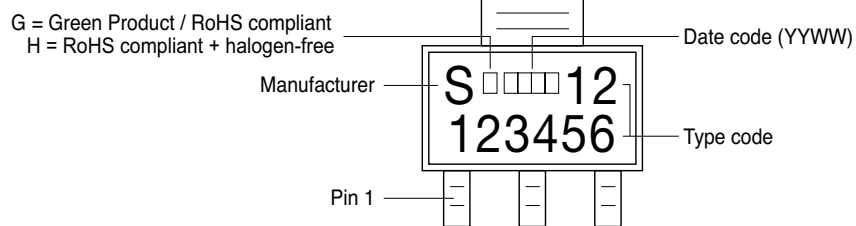

## Packing

Reel  $\varnothing 180\text{mm}$  = 1.000 Pieces/Reel

Reel  $\varnothing 330\text{mm}$  = 4.000 Pieces/Reel

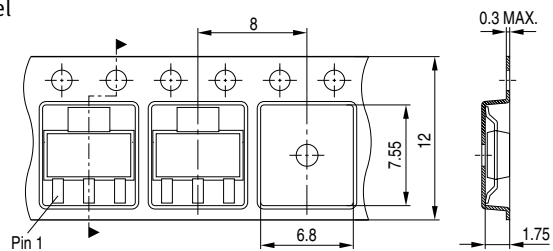

All dimensions in mm

# SOT-323

## Package Outline

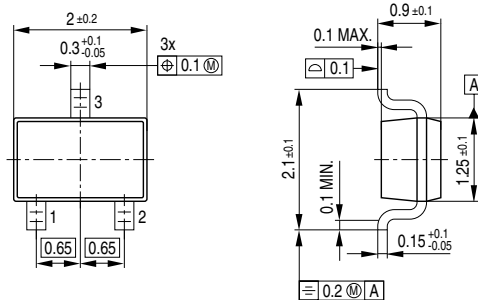

## Foot Print

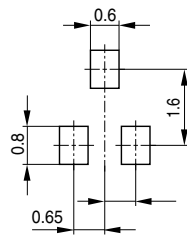

## Marking Layout

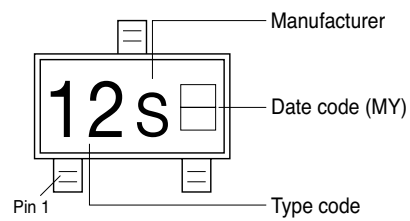

## Packing

Reel  $\varnothing 180\text{mm}$  = 3.000 Pieces/Reel

Reel  $\varnothing 330\text{mm}$  = 10.000 Pieces/Reel

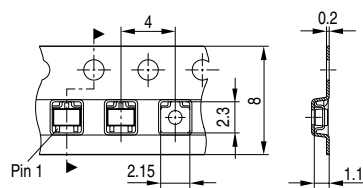

All dimensions in mm

# SOT-363

## Package Outline

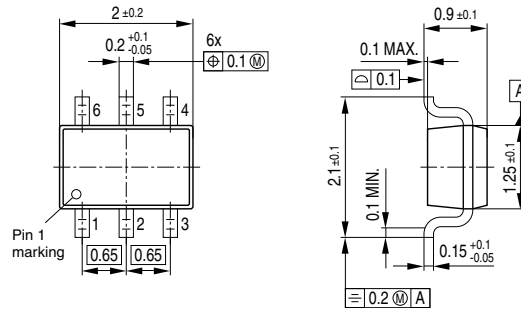

## Foot Print

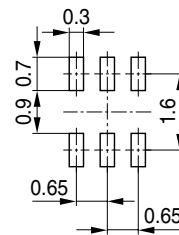

## Marking Layout

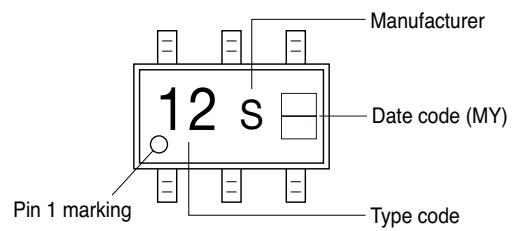

## Packing

Reel  $\varnothing 180$ mm = 3.000 Pieces/Reel  
 Reel  $\varnothing 330$ mm = 10.000 Pieces/Reel

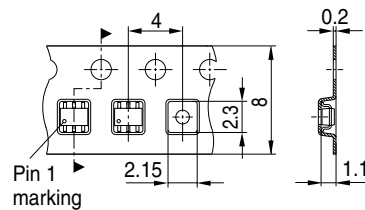

All dimensions in mm

# TSOP-6

## Package Outline

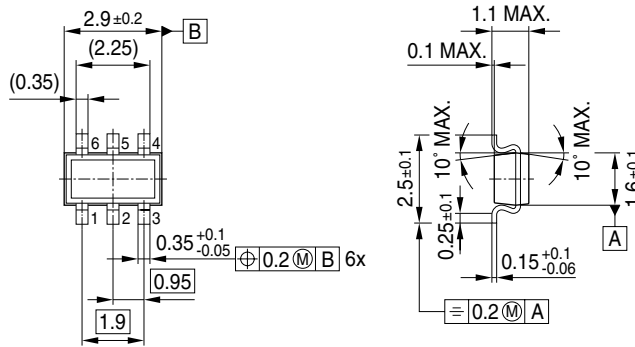

## Foot Print

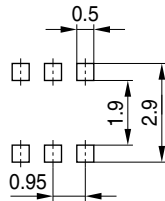

Remark: Wave soldering possible dep. on customers process conditions

## Marking Layout

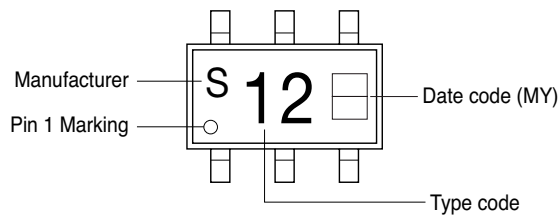

## Packing

Reel ø180mm = 3.000 Pieces/Reel

Reel ø330mm = 10.000 Pieces/Reel

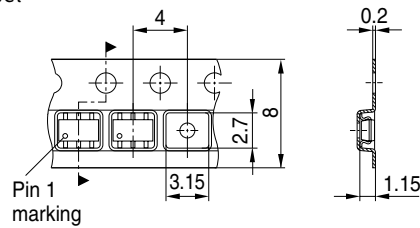

All dimensions in mm

# S308

## Package Outline

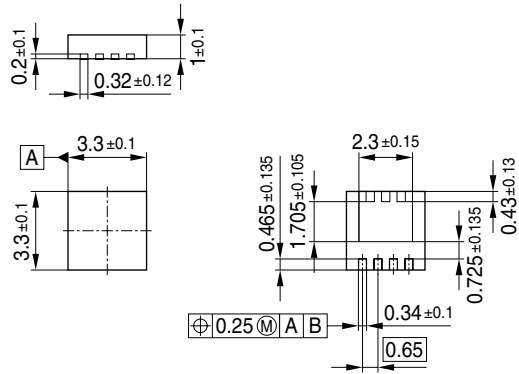

## Foot Print

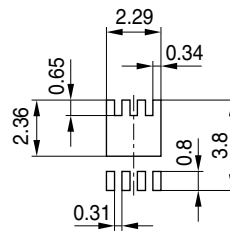

## Marking Layout

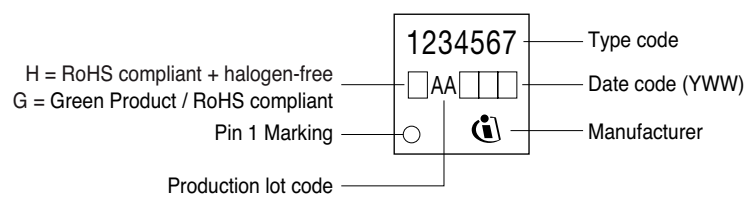

## Packing

Reel  $\varnothing 330\text{mm}$  = 5.000 Pieces/Reel

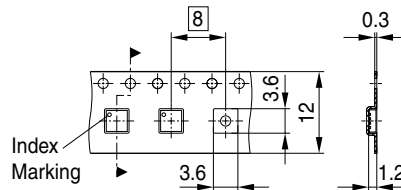

All dimensions in mm

# S308 fused leads

## Package Outline

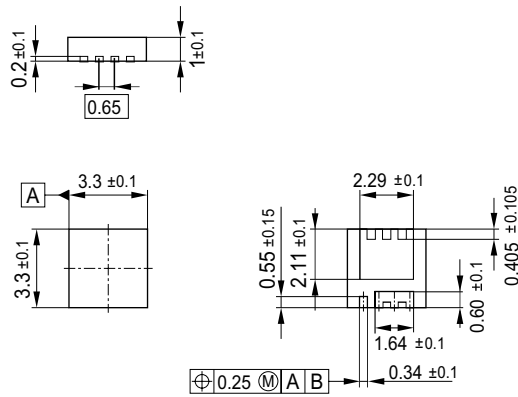

## Foot Print

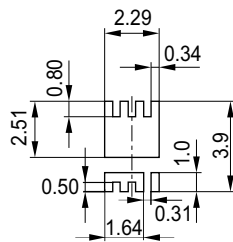

## Marking Layout

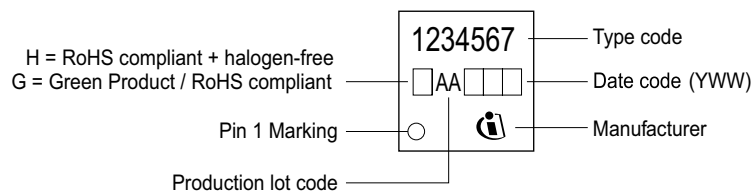

## Packing

Reel ø330mm = 5.000 Pieces/Reel

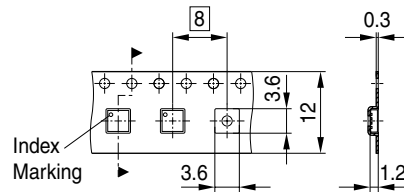

All dimensions in mm

# PowerStage 3x3

## Package Outline

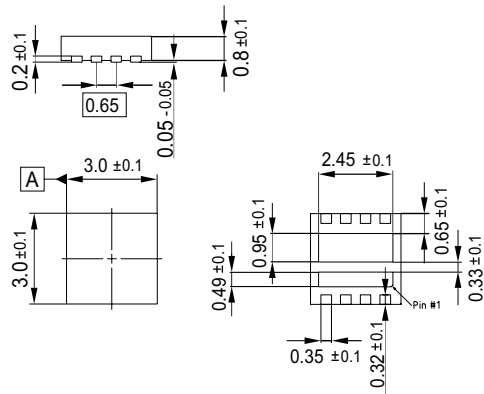

## Foot Print

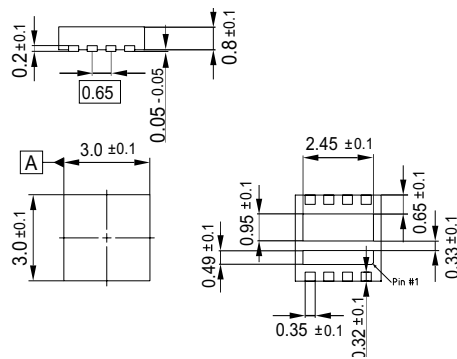

## Marking Layout

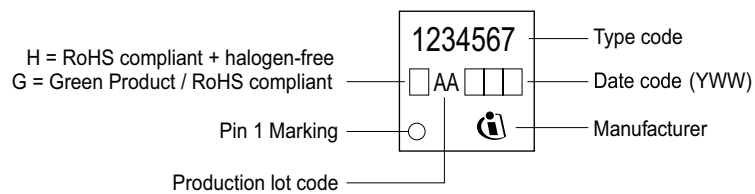

## Packing

Reel ø330mm = 5.000 Pieces/Reel

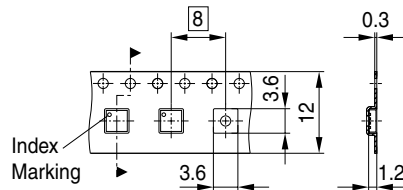

All dimensions in mm

# SuperS08

## Package Outline

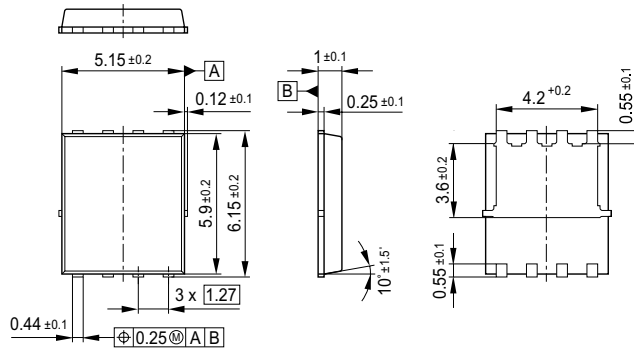

## Foot Print

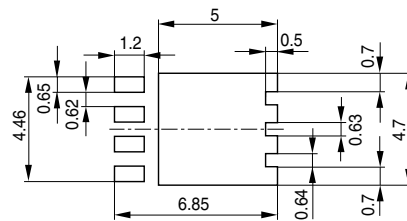

## Marking Layout

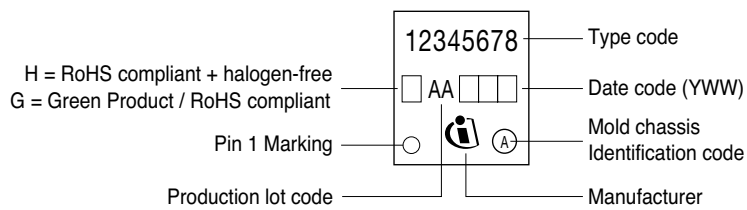

## Packing

Reel ø330mm = 5.000 Pieces/Reel

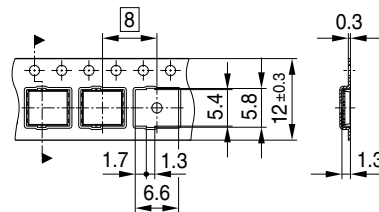

All dimensions in mm

# VSON

## Package Outline

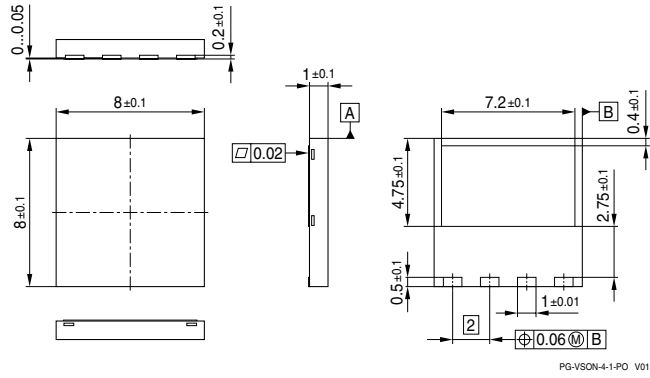

## Foot Print

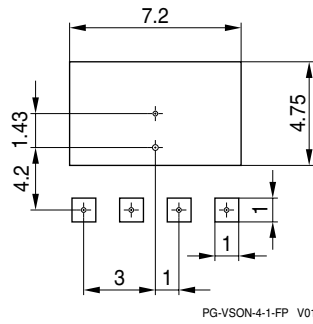

## Marking Layout

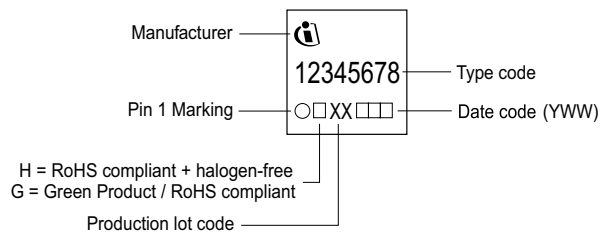

## Packing

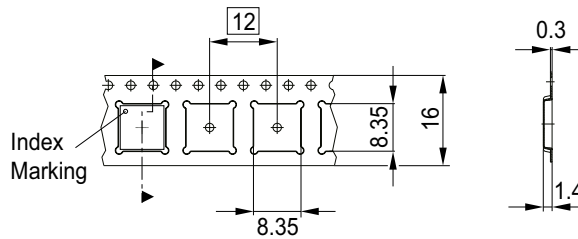

All dimensions in mm

# SuperSO8 dual

## Package Outline

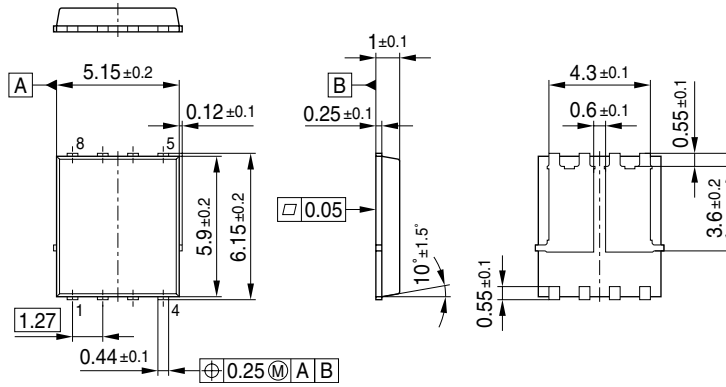

## Foot Print

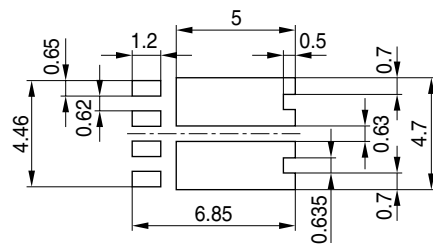

## Marking Layout

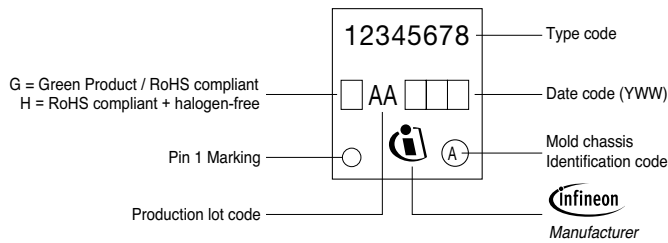

## Packing

Reel ø330mm = 5.000 Pieces/Reel

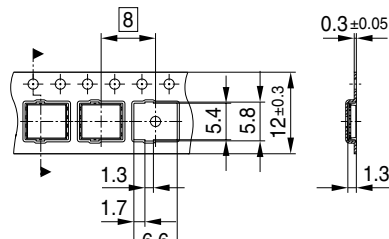

All dimensions in mm

# CanPAK™ SJ

## Package Outline

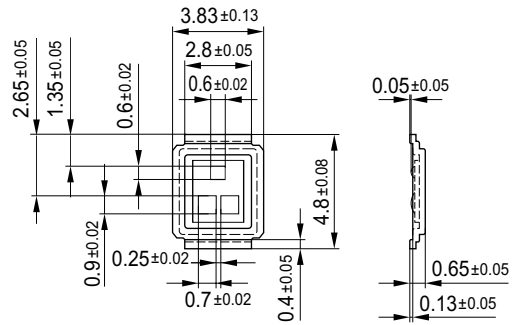

## Foot Print

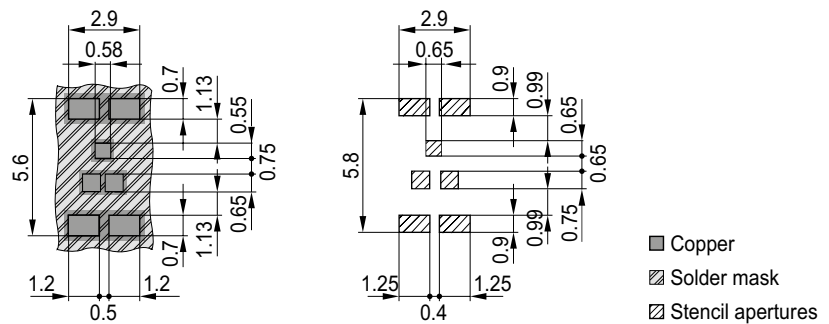

## Marking Layout

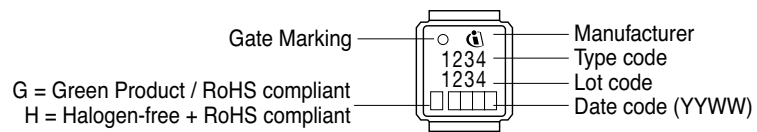

## Packing

Reel  $\varnothing$ 177mm = 1.000 Pieces/Reel

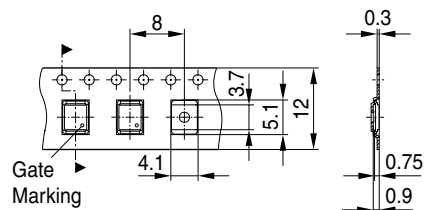

All dimensions in mm

# CanPAK™ SQ

## Package Outline

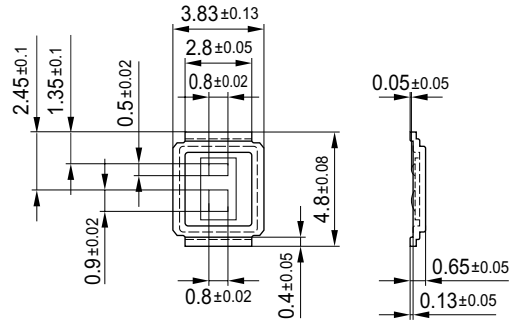

## Foot Print

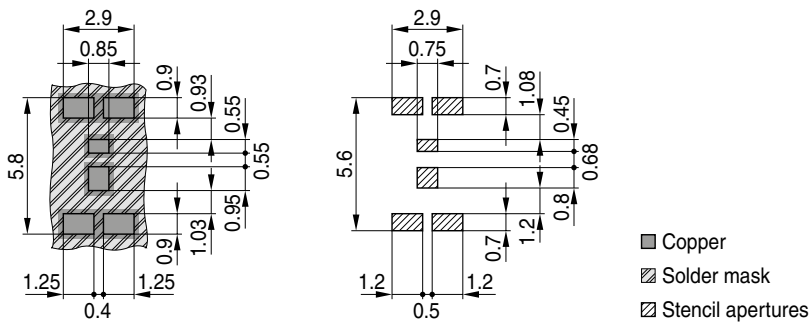

## Marking Layout

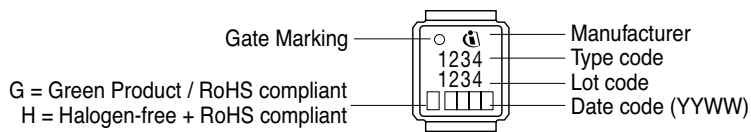

## Packing

Reel  $\varnothing 177\text{mm}$  = 1.000 Pieces/Reel

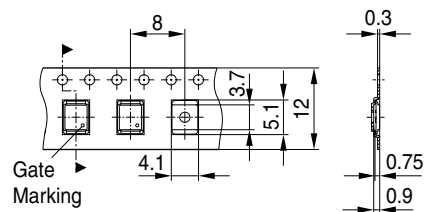

All dimensions in mm

# CanPAK™ ST

## Package Outline

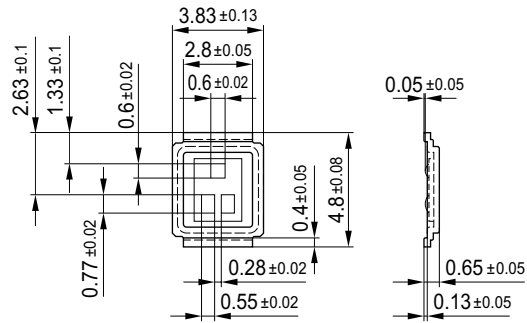

## Foot Print

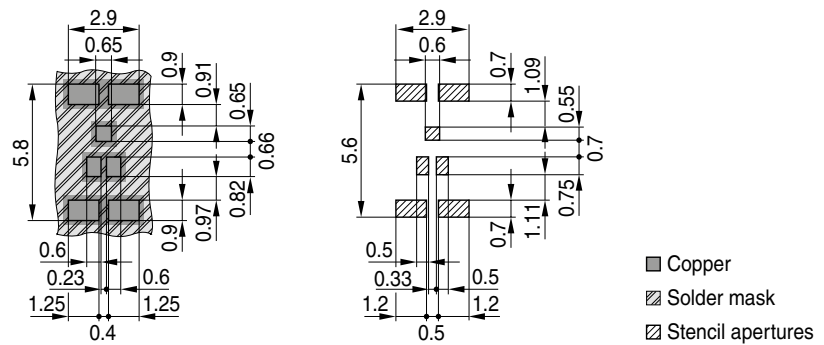

## Marking Layout

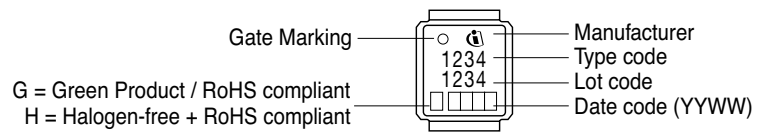

## Packing

Reel  $\varnothing 177\text{mm}$  = 1.000 Pieces/Reel

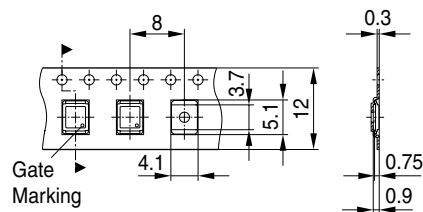

All dimensions in mm

# CanPAK™ MN

## Package Outline

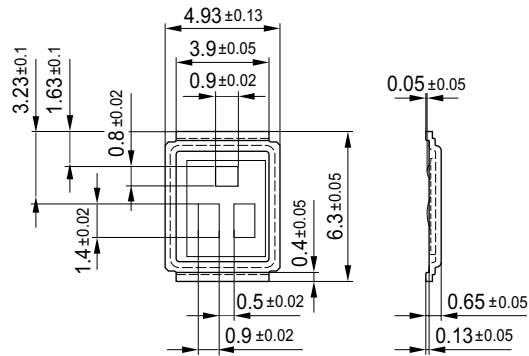

## Foot Print

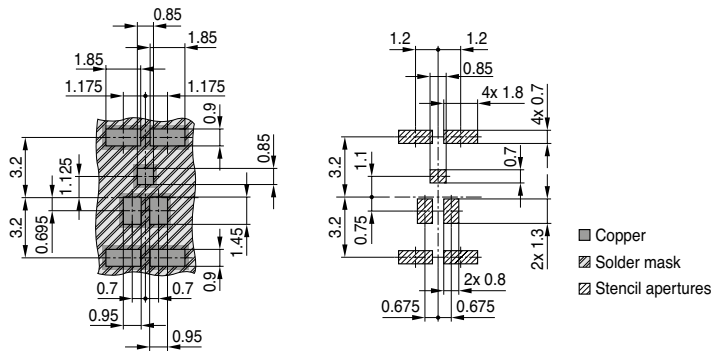

## Marking Layout

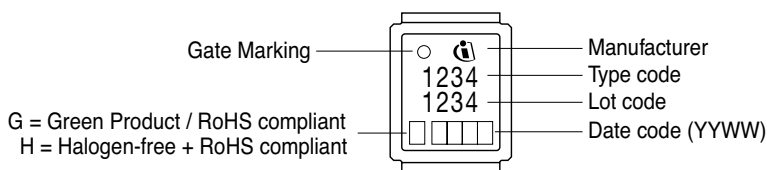

## Packing

Reel ø177mm = 1.000 Pieces/Reel

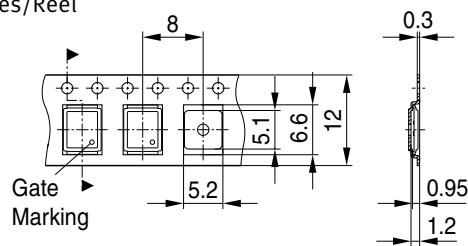

All dimensions in mm

# CanPAK™ MP

## Package Outline

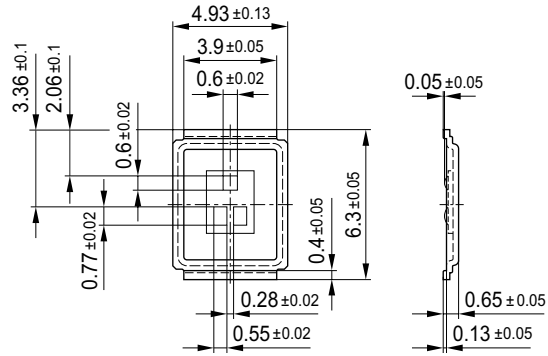

## Foot Print

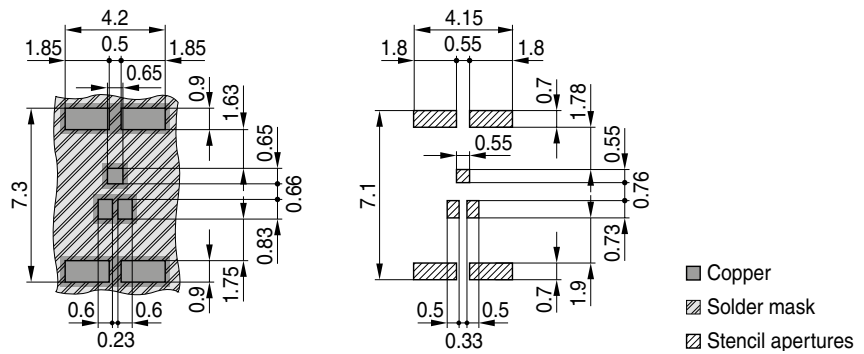

## Marking Layout

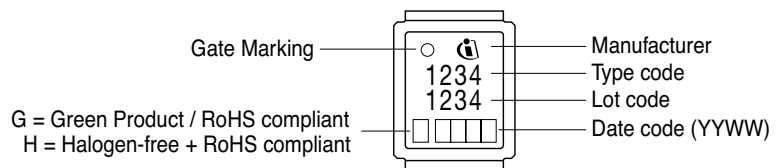

## Packing

Reel  $\varnothing 177\text{mm}$  = 1.000 Pieces/Reel

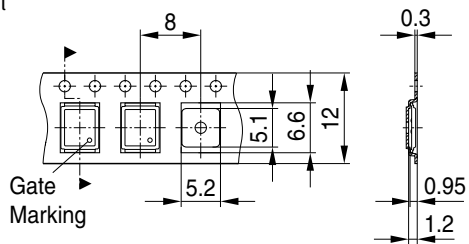

All dimensions in mm

# CanPAK™ MX

## Package Outline

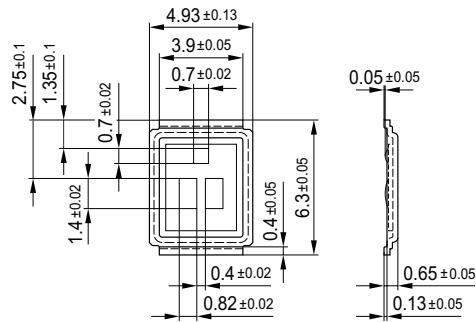

## Foot Print

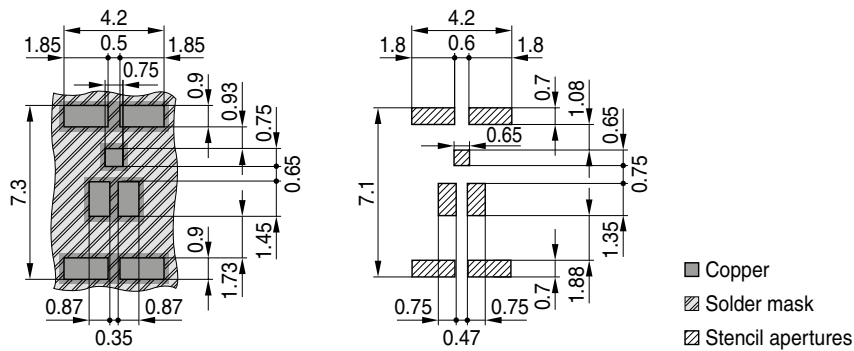

## Marking Layout

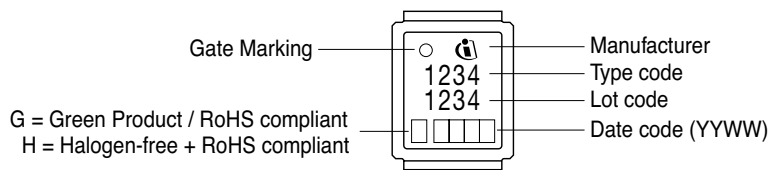

## Packing

Reel ø177mm = 1.000 Pieces/Reel

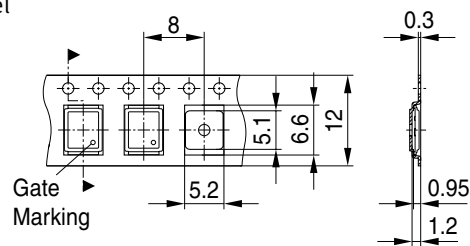

All dimensions in mm

# CanPAK™ MZ

## Package Outline

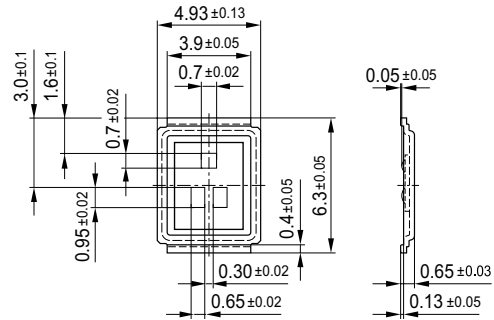

## Foot Print

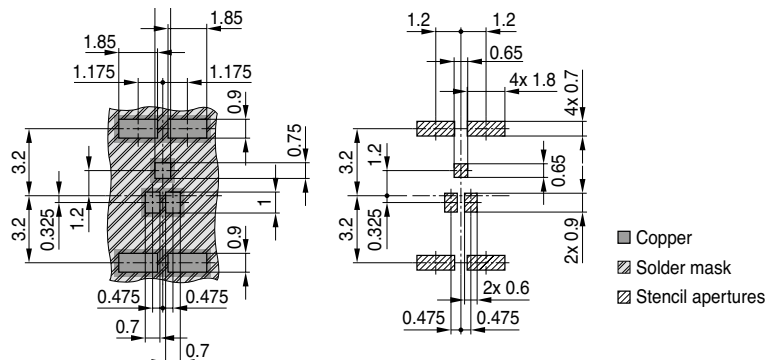

## Marking Layout

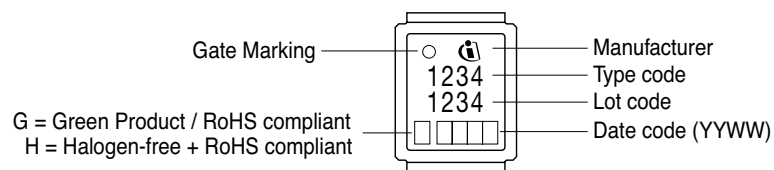

## Packing

Reel ø177mm = 1.000 Pieces/Reel

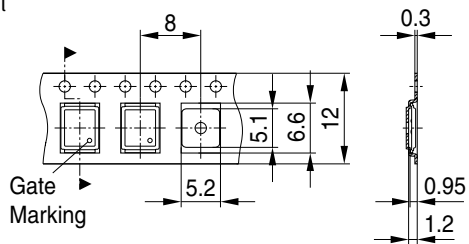

All dimensions in mm

# TDSON-10

## Package Outline

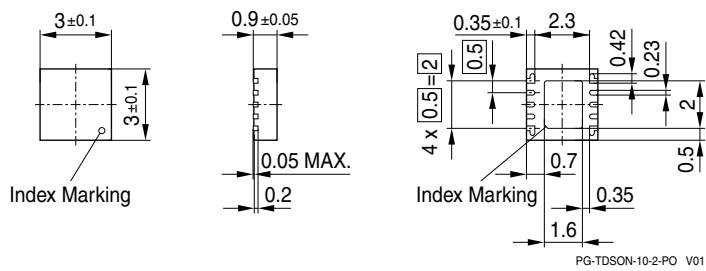

## Foot Print

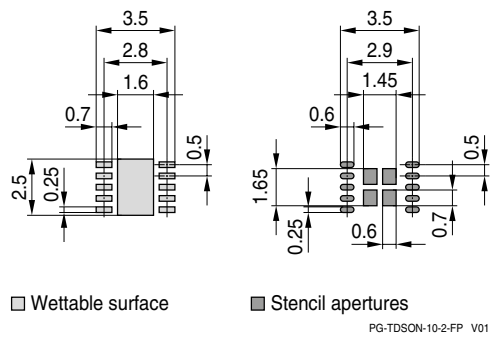

## Marking Layout

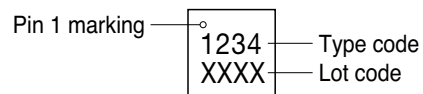

## Packing

Reel  $\varnothing 330$ mm = 5.000 Pieces/Reel

Drawing available on request

All dimensions in mm

# DIP-7

## Package Outline

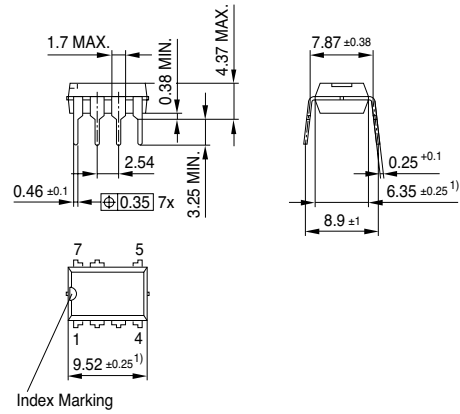

1) Does not include plastic or metal protrusion of 0.25 max. per side

## Marking Layout

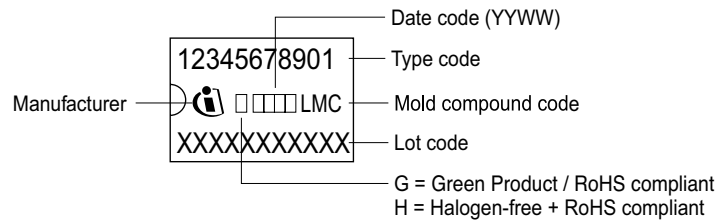

## Packing

Pieces/Tube: 20

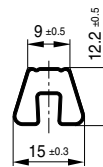

All dimensions in mm

# DIP-8

## Package Outline

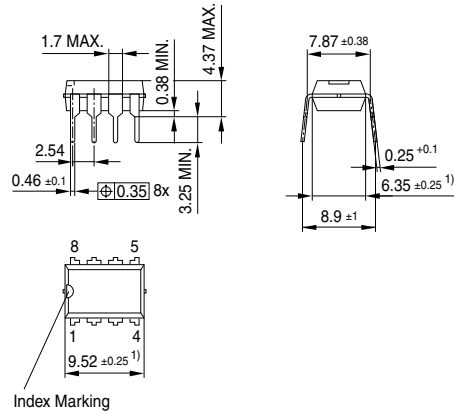

1) Does not include plastic or metal protrusion of 0.25 max. per side

## Marking Layout

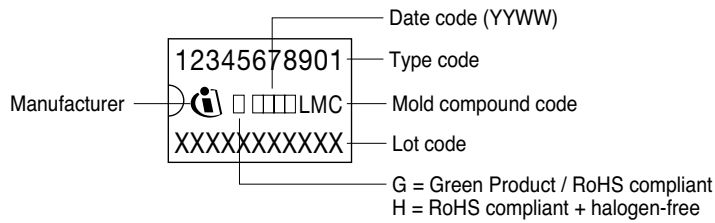

## Packing

Pieces/Tube: 20

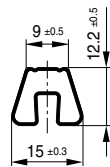

All dimensions in mm

# DIP-14

## Package Outline

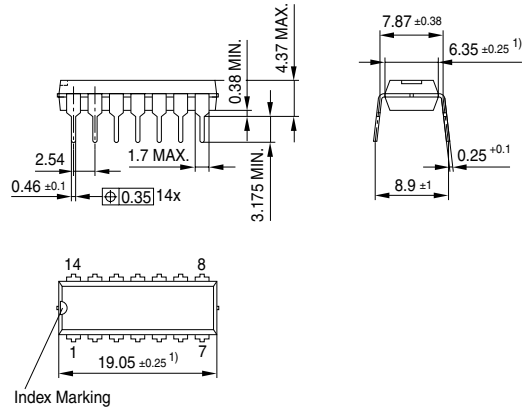

1) Does not include plastic or metal protrusion of 0.25 max. per side

## Marking Layout

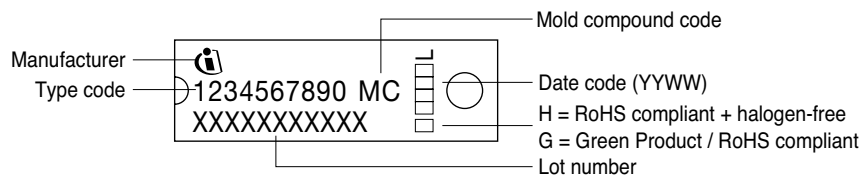

## Packing

Pieces/Tube: 20

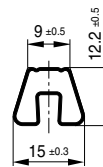

All dimensions in mm

# DIP-20

## Package Outline

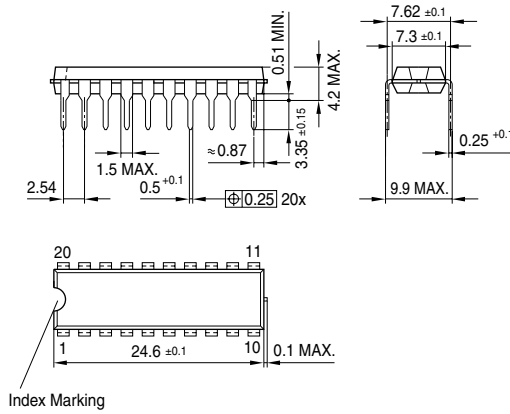

Index Marking

## Marking Layout

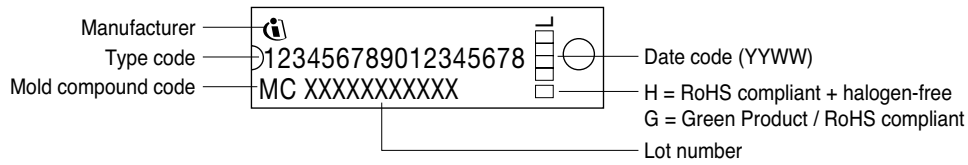

## Packing

Pieces/Tube: 20

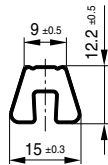

All dimensions in mm

# TSSOP-48

## Package Outline

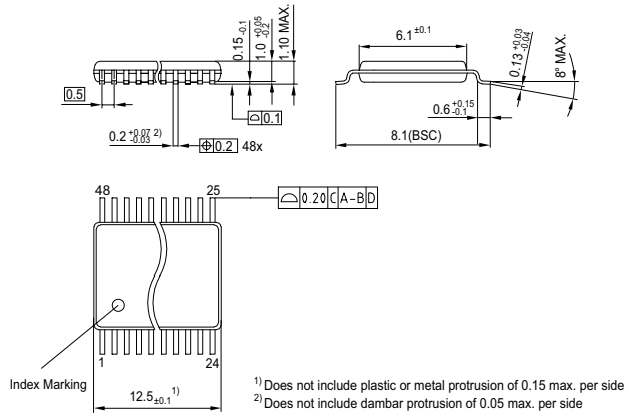

## Foot Print

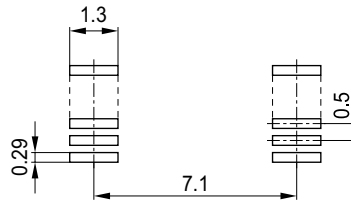

## Marking Layout

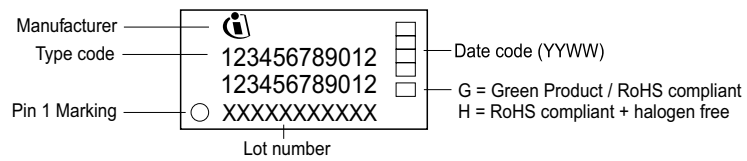

## Packing

Drawing available on request

All dimensions in mm

# DSO-36

## Package Outline

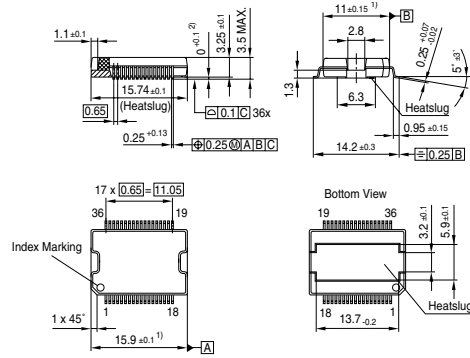

1) Does not include plastic or metal protrusion of 0.15 max. per side  
 2) Stand off

PO-ENH-36-10 -12 -15 -16 -21 -23 -26 -27 V01

## Foot Print

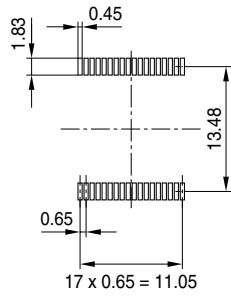

HLG09551

## Marking Layout

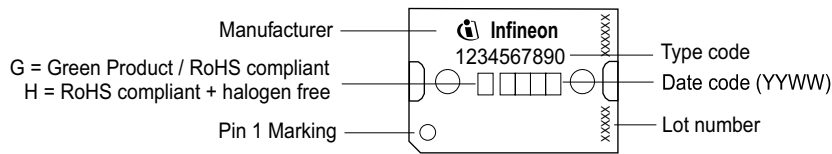

## Packing

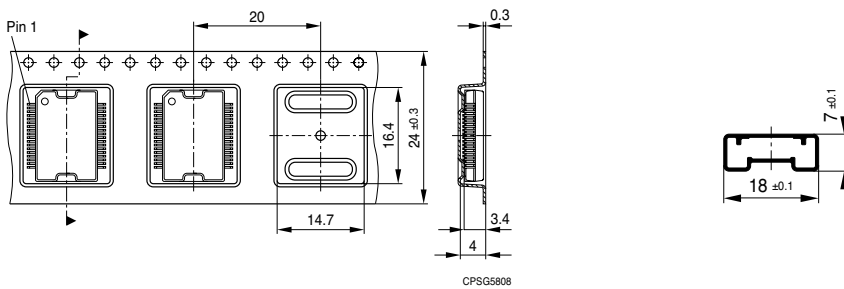

CPSG5808

All dimensions in mm

# IQFN-40

## Package Outline

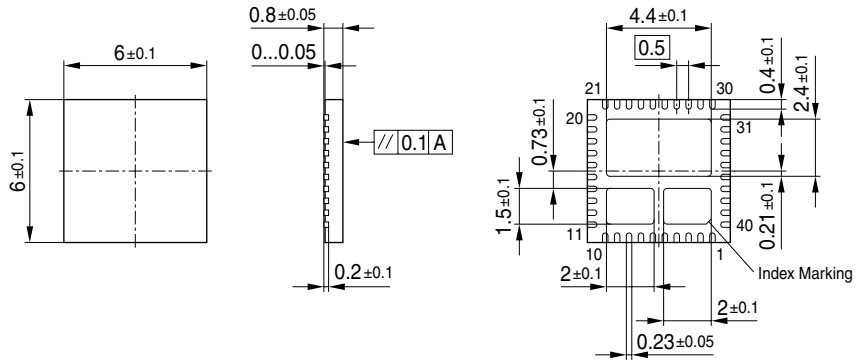

PG-IQFN-40-1-PO V01

## Foot Print

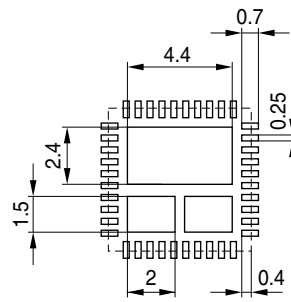

PG-IQFN-40-1-FP V01

## Marking Layout

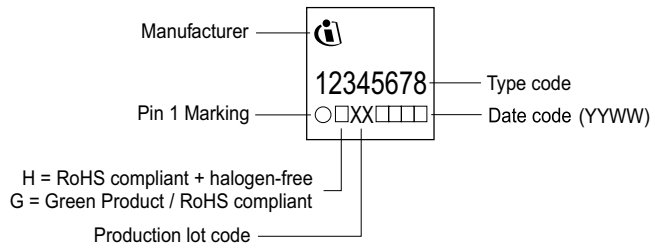

## Packing

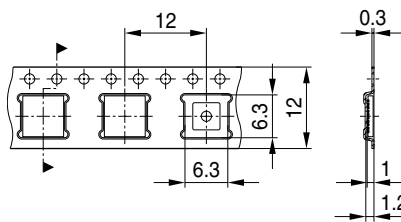

PG-IQFN-40-1-TP V01

All dimensions in mm

# TSSOP-28

## Package Outline

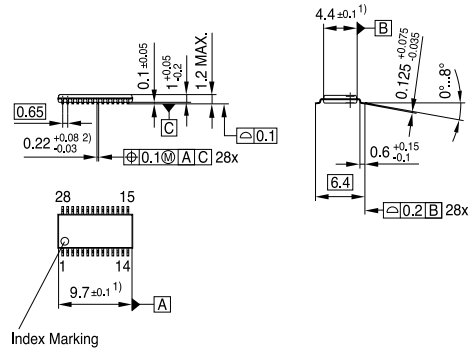

- <sup>1)</sup> Does not include plastic or metal protrusion of 0.15 max. per side  
<sup>2)</sup> Does not include dambar protrusion

## Foot Print

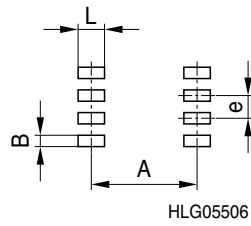

## Marking Layout

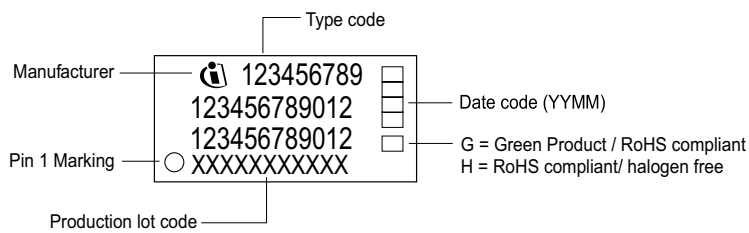

## Packing

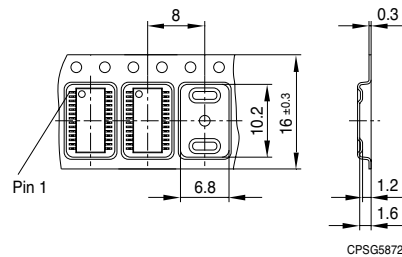

All dimensions in mm

# DSO-28

## Package Outline

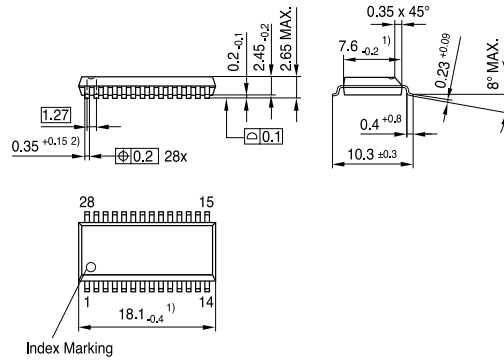

<sup>1)</sup> Does not include plastic or metal protrusion of 0.15 max. per side  
<sup>2)</sup> Does not include dambar protrusion of 0.05 max. per side

## Foot Print

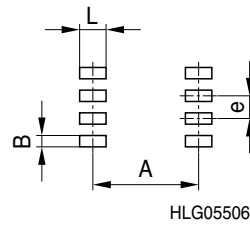

## Marking Layout

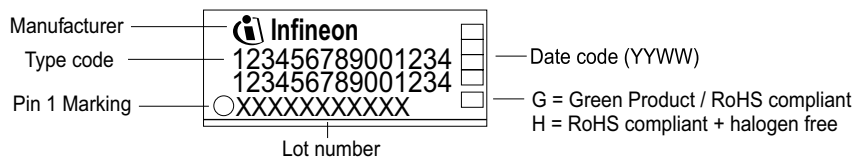

## Packing

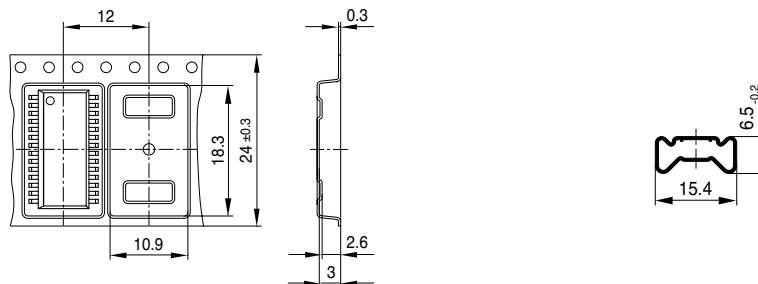

All dimensions in mm

# VQFN-68

## Package Outline

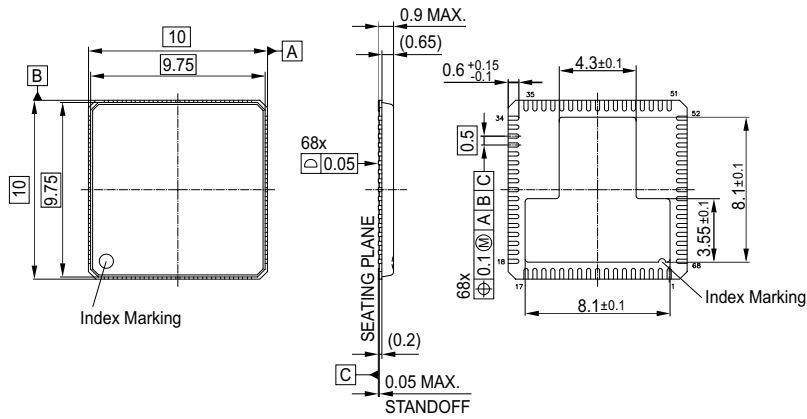

## Foot Print

Drawing available on request

## Marking Layout

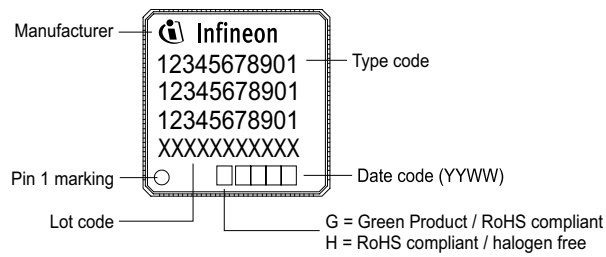

## Packing

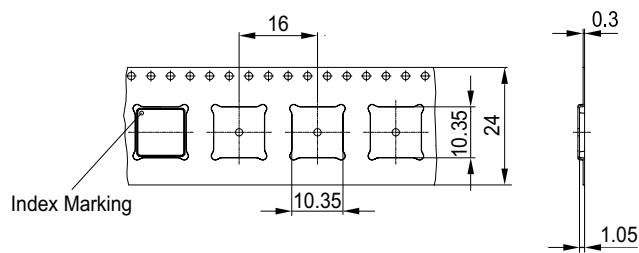

All dimensions in mm

# Packaging Information

## Tape and Reel

(DIN IEC 60 286-3)

Please consult your nearest Infineon sales offices ([www.infineon.com/sales](http://www.infineon.com/sales)) if you have any queries relating to additional dimensions, dimensional tolerances or variations.

### Tape and Reel made of Plastic

∅ Reel 180mm and 330mm

Carrier tape width: 8, 12mm

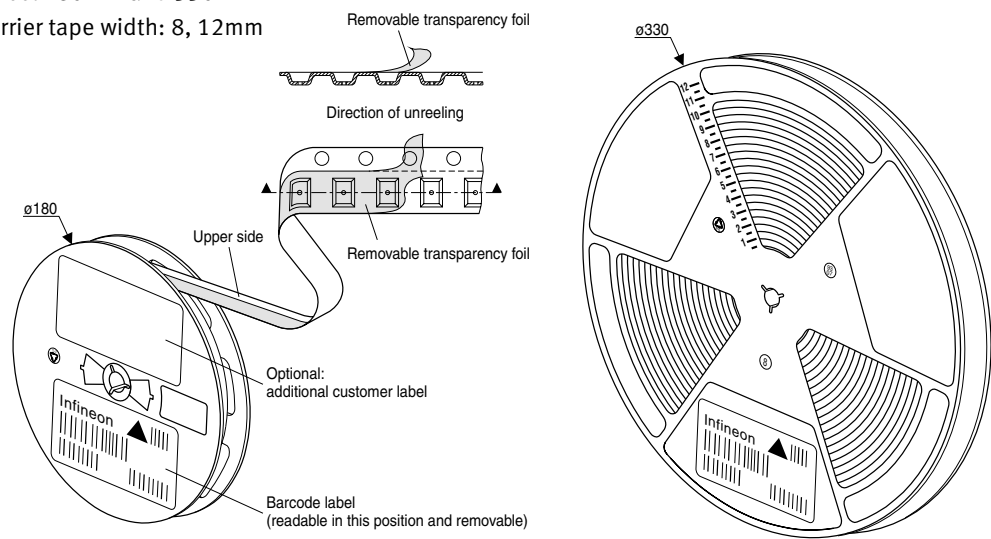

### Fixing on the Tape

Carrier tape width:  $\leq 12$ mm

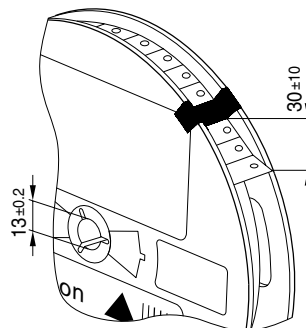

## Direction of Unreeling

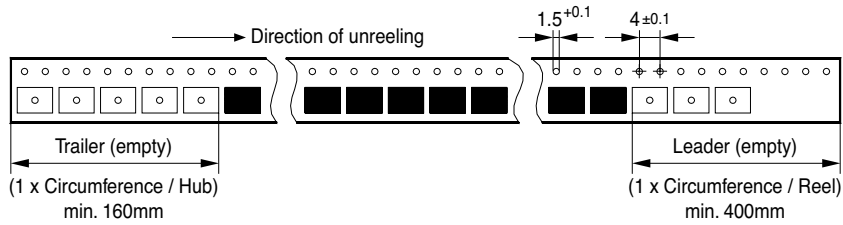

There shall be a leader of 400mm minimum of cover tape, which includes at least 100mm of carrier tape with empty compartments. All the leader may consist of the carrier tape with empty compartments, sealed by cover tape.

## Labels and Boxes

For 1 Tape (resembling a pizza box)

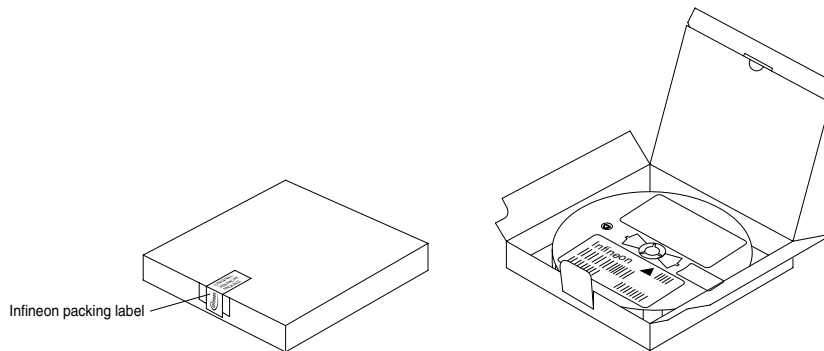

Up to 10 Tapes

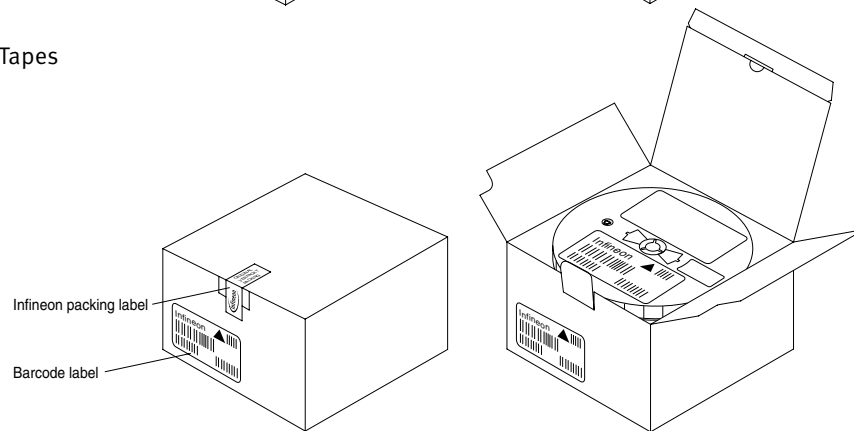

# Packaging Information

## Tube (DIN IEC60 286-4)

(DIN IEC60 286-4)

Please consult your nearest Infineon sales offices ([www.infineon.com/sales](http://www.infineon.com/sales)) if you have any queries relating to additional dimensions, dimensional tolerances or variations.

### Tube and Packing

Standard Length: 528<sub>±</sub>mm;  
coated (unless stated to the contrary)

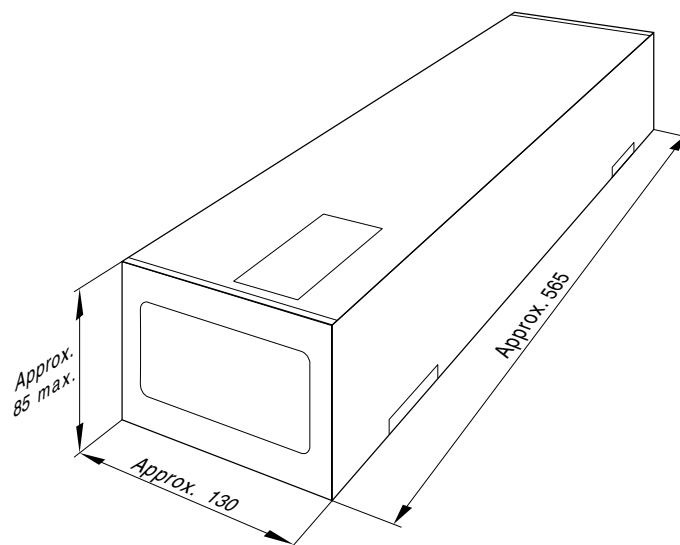
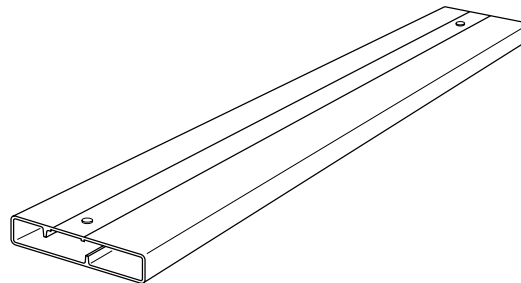

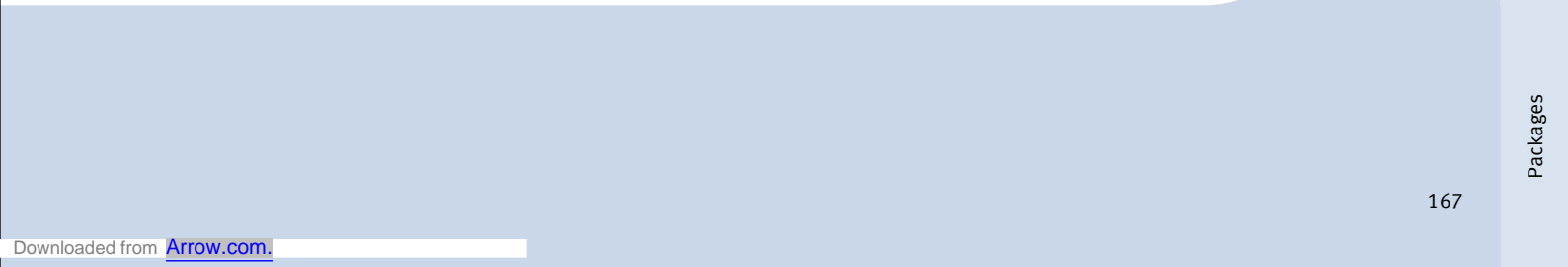
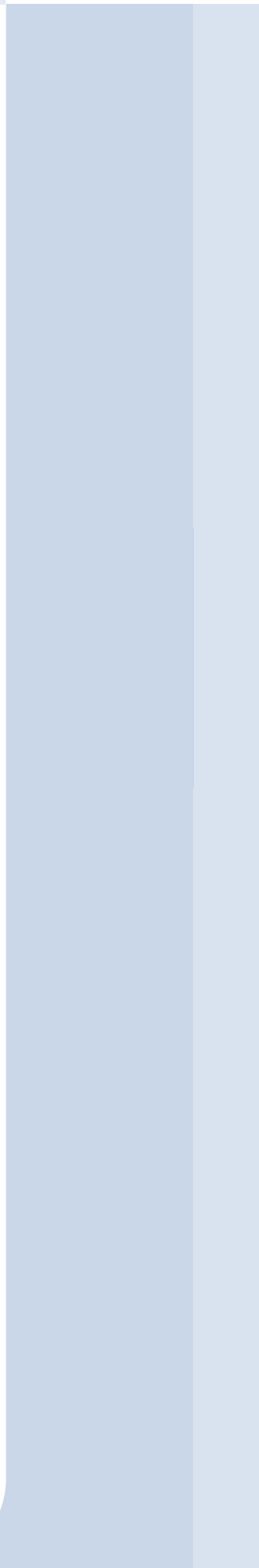
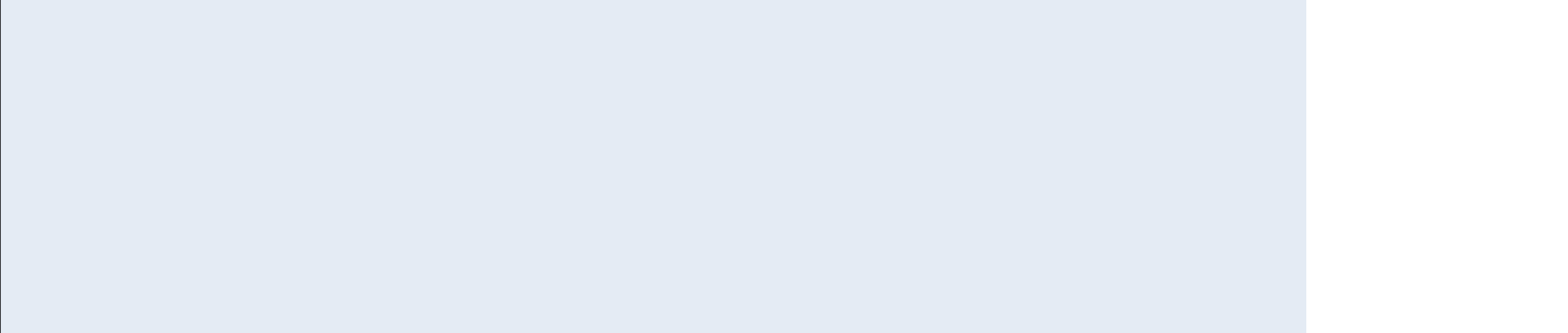

# Catalog Support

We update the Selection Guide on a regular basis on the internet to provide you with the latest information. Please have a look and find out about the newest products or package updates.

[www.infineon.com/PSDSelectionGuide](http://www.infineon.com/PSDSelectionGuide)

If you have feedback or any comment please go to:

[www.infineon.com/PSDSelectionGuide](http://www.infineon.com/PSDSelectionGuide)

Download electrical version:

[www.infineon.com/ePSDSelectionGuide](http://www.infineon.com/ePSDSelectionGuide)

You can order this catalog via phone: **00 800 951 951 951** (toll-free)

## Product Support

You can use our simulation and design tools for a first review and more information.

### PowerEsim - design and simulation tool for high voltage MOSFETs

PowerEsim is a CAD tool for designing switching power supplies. Design service is readily available anytime, anywhere. It is so easy to use through a generic Web browser that you don't need any training. [www.infineon.com/PowerEsim](http://www.infineon.com/PowerEsim)

### SimT - Design and simulation tool for low voltage MOSFETs

SimT provides detailed low voltage MOSFETs information for your specific application and operating conditions. Just enter the required operating conditions and the web-based application delivers quickly corresponding device.



Simply by inserting your converter requirements, SimT provides different solutions for your buck converter, optimized either in efficiency or cost, to fulfil your needs in each individual case.

Furthermore, SimT offers a complete analysis of your solution, including an online simulation based on Simetrix/Simplix. ([www.infineon.com/SimT](http://www.infineon.com/SimT))

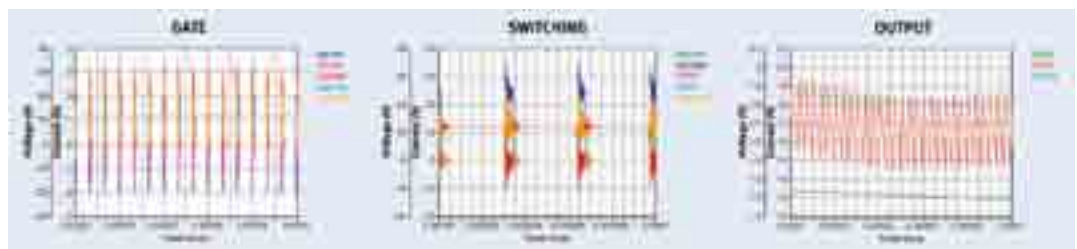

## Ask Infineon – Infineon Hotline-Service at your fingertips. Where you need it. When you need it.

Infineon offers its toll-free 0800 service hotline as one central number, available 24 / 7 in English and German.

Our global connection service goes way beyond standard operating and switchboard services by offering qualified support on the phone. Call us!

- Germany ..... 0800 951 951 951
- USA ..... 1866 951 9519
- International ..... 00 800 951 951 951
- Direct access ..... +49 89 234-0 (interconnection fee)

## Where to Buy Infineon Distribution Partners and Sales Offices

Please use our location finder to get in contact with your nearest Infineon distributor or sales office.

[www.infineon.com/WhereToBuy](http://www.infineon.com/WhereToBuy)

Infineon Technologies – innovative semiconductor solutions for Energy Efficiency, mobility and security.

Published by  
Infineon Technologies Austria AG  
9500 Villach, Austria

© 2011 Infineon Technologies AG.  
All Rights Reserved.

Visit us:  
[www.infineon.com](http://www.infineon.com)

Order Number: B152-H9571-G1-X-7600  
Date: 06 / 2011

### ATTENTION PLEASE!

The information given in this document shall in no event be regarded as a guarantee of conditions or characteristics ("Beschaffenheitsgarantie"). With respect to any examples or hints given herein, any typical values stated herein and/or any information regarding the application of the device, Infineon Technologies hereby disclaims any and all warranties and liabilities of any kind, including without limitation warranties of non-infringement of intellectual property rights of any third party.

### INFORMATION

For further information on technology, delivery terms and conditions and prices please contact your nearest Infineon Technologies Office ([www.infineon.com](http://www.infineon.com)).

### WARNINGS

Due to technical requirements components may contain dangerous substances. For information on the types in question please contact your nearest Infineon Technologies Office. Infineon Technologies Components may only be used in life-support devices or systems with the express written approval of Infineon Technologies, if a failure of such components can reasonably be expected to cause the failure of that life-support device or system, or to affect the safety or effectiveness of that device or system. Life support devices or systems are intended to be implanted in the human body, or to support and/or maintain and sustain and/or protect human life. If they fail, it is reasonable to assume that the health of the user or other persons may be endangered.