

1

2

3

4

A

B

C

D

A

B

C

D

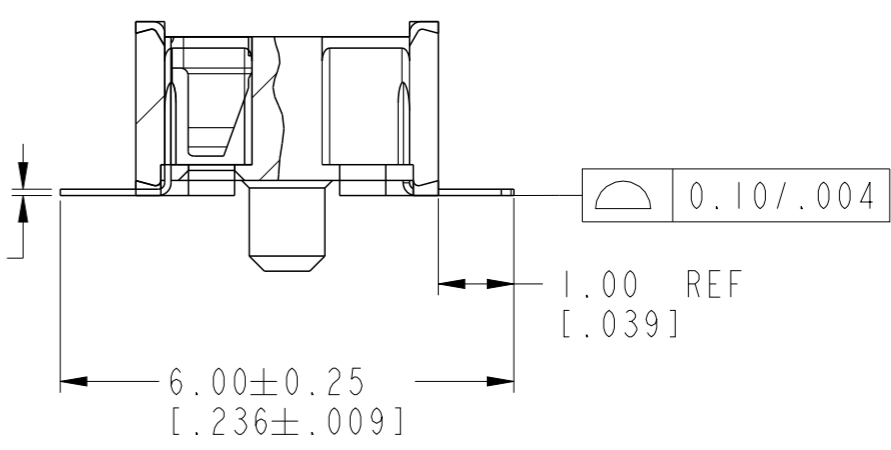
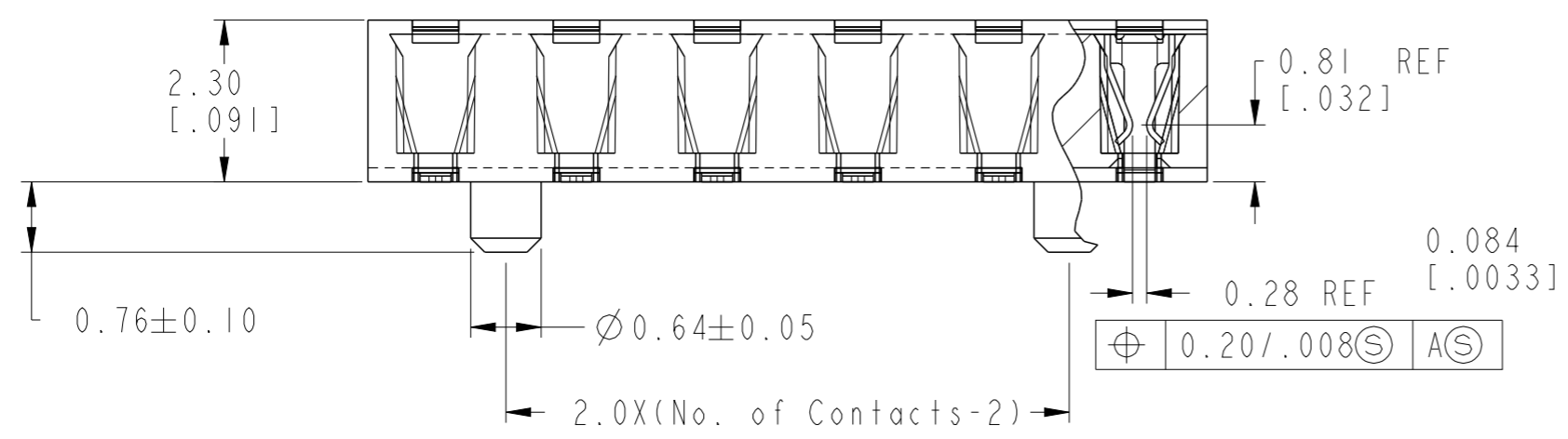
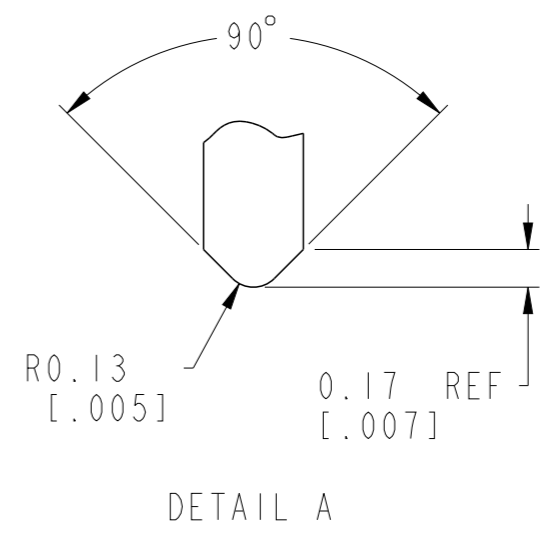
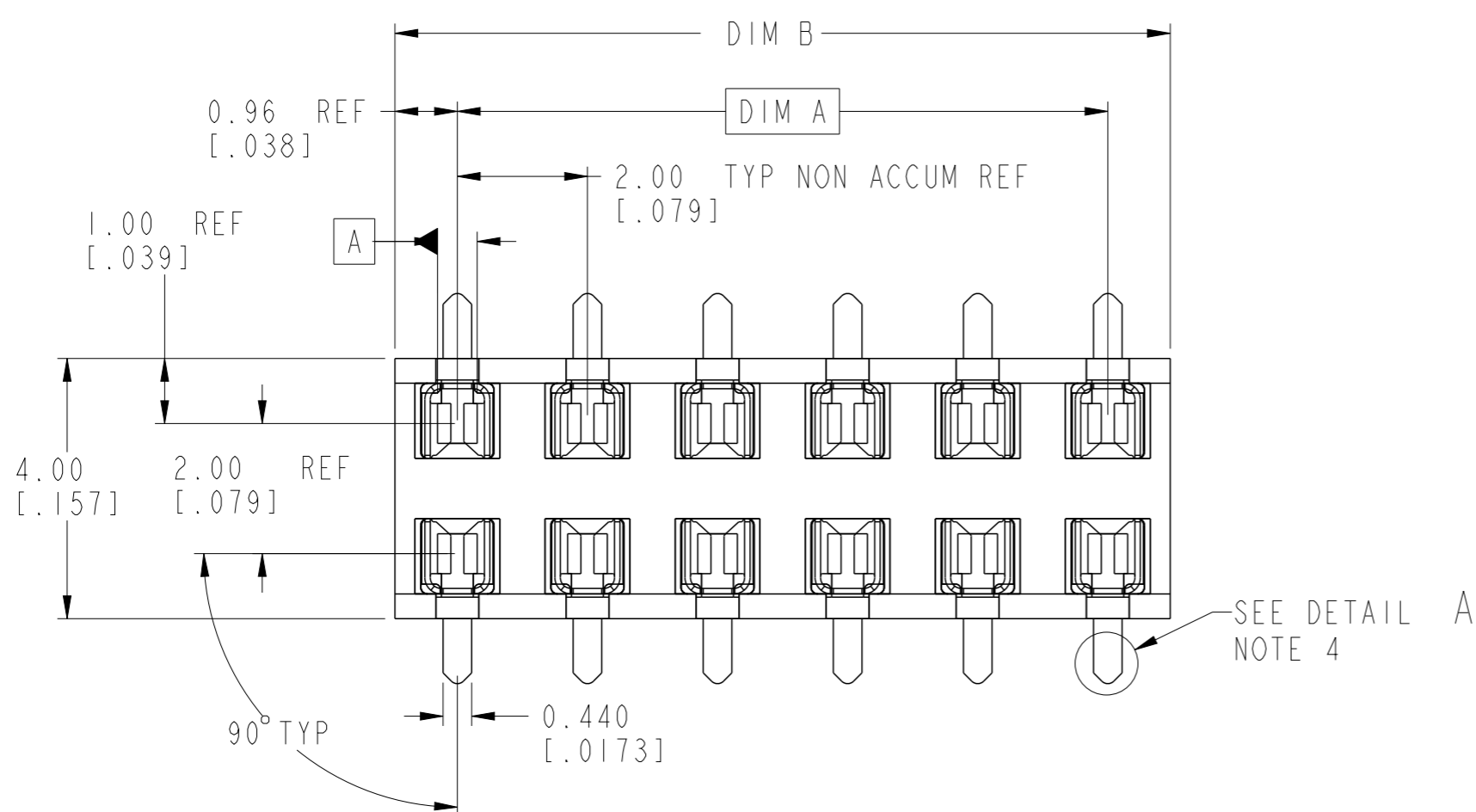

Copyright FCI.

spec ref	-	dr	Su-Hua Miao	2012/11/23	projection	MM / INCH	size	A3	scale	10:1
tolerance std	ISO 406 ISO 1101	eng	Su-Hua Miao	2012/11/26			ecn no		-	
TOLERANCES UNLESS OTHERWISE SPECIFIED		chr	-	-			rel level		Released	
surface	✓	appr	Rick Bian	2012/11/26	product family		LPVCC		-	
ISO 1302	linear	0.X	±0.3		title LOW PROFILE VCC BOTTOM ENTRY SMT 2.3 ASSY WITH POST		dwg no 10122189		rev A	
		0.XX	±0.13							
		0.XXX	±0.051							
angular	0°	±2°	www.fci.com	cat. no.	-	Product - Customer Drw		sheet 1 of 2		

PRODUCT NO	POSITIONS	DIM. A	DIM. B
10122189-X04	2 X 2	2.00 / .079	3.92 / .154
-X06	2 X 3	4.00 / .158	5.92 / .233
-X08	2 X 4	6.00 / .236	7.92 / .312
-X10	2 X 5	8.00 / .315	9.92 / .391
-X12	2 X 6	10.00 / .394	11.92 / .469
-X14	2 X 7	12.00 / .472	13.92 / .548
-X16	2 X 8	14.00 / .551	15.92 / .627
-X18	2 X 9	16.00 / .630	17.92 / .706
-X20	2 X 10	18.00 / .709	19.92 / .784
-X22	2 X 11	20.00 / .787	21.92 / .863
-X24	2 X 12	22.00 / .866	23.92 / .942
-X26	2 X 13	24.00 / .945	25.92 / 1.020
-X28	2 X 14	26.00 / 1.024	27.92 / 1.099
-X30	2 X 15	28.00 / 1.102	29.92 / 1.178

CONTACT AREA PLATING OPTIONS	
0	=0.20um/8u"Au CONTACT AREA.
1	=0.76um/30u"Au CONTACT AREA.
3	=0.38um/15u"Au CONTACT AREA.
6	=0.76um/30u"GXT CONTACT AREA.

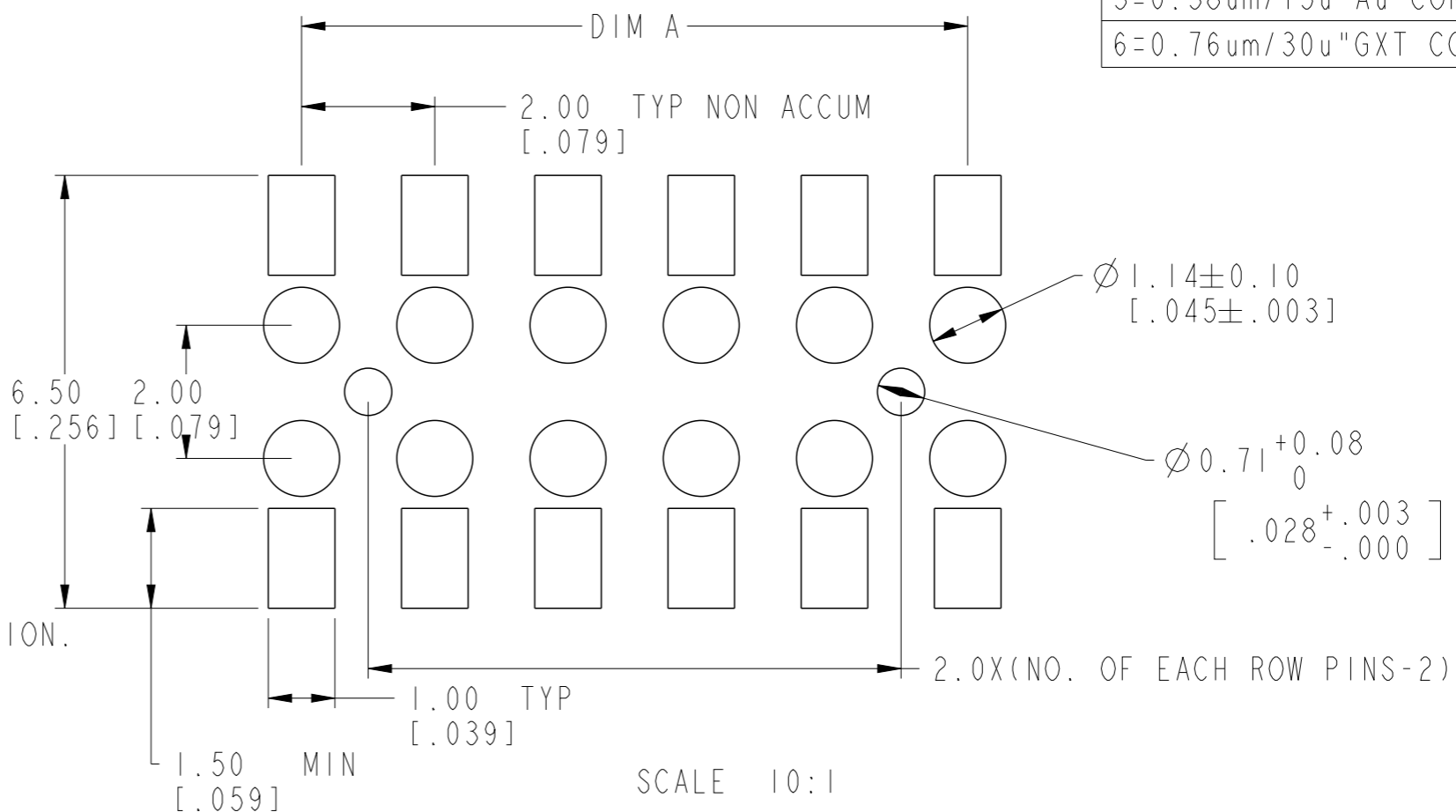

- NOTES:
- HOUSING MAT'L : HIGH TEMP PLASTIC.
 - TERMINAL MAT'L : BeCu.
 - TERMINAL RETENTION 0.25Kg/0.55 Lbs.
 - 'V' CUT OPTIONAL - MANUFACTURING PROCESS OPTION.
 - PRODUCT DESCRIPTION CODE:



6. PACKAGING:
- XXXXX-XXX ---STD PACKAGING IN TUBE.
 - XXXXX-XXXTR ---TAPE AND REEL (CONDUCTIVE) PACKAGING WITH PICK-UP CAP (SEE FIG 1).
 - XXXXX-XXXTRN ---TAPE AND REEL (CONDUCTIVE) PACKAGING WITHOUT PICK-UP CAP.
 - XXXXX-XXXCR ---TAPE AND REEL (NON-CONDUCTIVE) PACKAGING WITH PICK-UP CAP (SEE FIG 1).
 - XXXXX-XXXCRN ---TAPE AND REEL (NON-CONDUCTIVE) PACKAGING WITHOUT PICK-UP CAP.

7. SOLDER TAILS PLATING:
- SOLDERTAIL OF P/N:91596-XXX IS TIN/LEAD PLATED.
 - SOLDERTAIL OF P/N:91596-XXXLF IS GOLD FLASH PLATED.
8. THE HOUSING WILL WITHSTAND EXPOSURE TO 255°C PEAK TEMPERATURE FOR 10 SECONDS IN A CONVECTION, INFRA-RED OR VAPOR PHASE REFLOW OVEN.
9. THIS PRODUCT MEETS EUROPEAN UNION DIRECTIVES AND OTHER COUNTRY REGULATIONS AS DESCRIBED IN GS-22-008.

SCALE 10:1
RECOMMENDED PAD LAYOUT

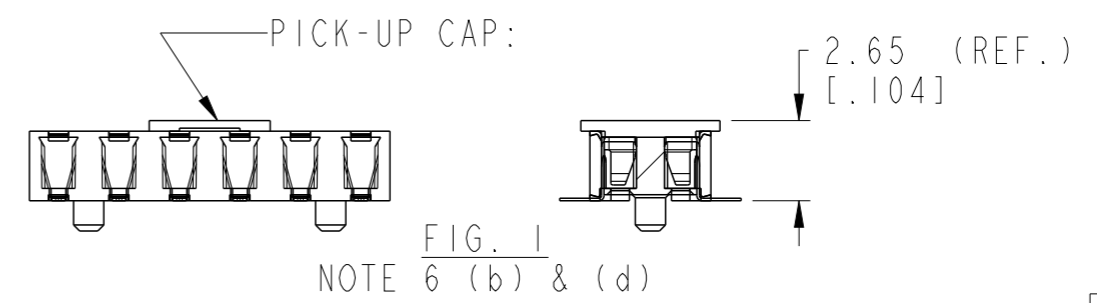

CONFIDENTIAL

dr	Su-Hua Miao	2012/11/23	projection MM / INCH	size	A3	scale	10:1
eng	Su-Hua Miao	2012/11/26		ecn no	-		
chr	-	-		rel level	Released		
appr	Rick Bian	2012/11/26	product family	LPVCC	rev	A	
www.fci.com		cat. no.	Product - Customer Drw		sheet 2 of 2		

Copyright FCI.