

LOC	DIST	REVISIONS			
GE	00	REV	DATE	BY	APPD
		A	16NOV2009	DLD	SLM

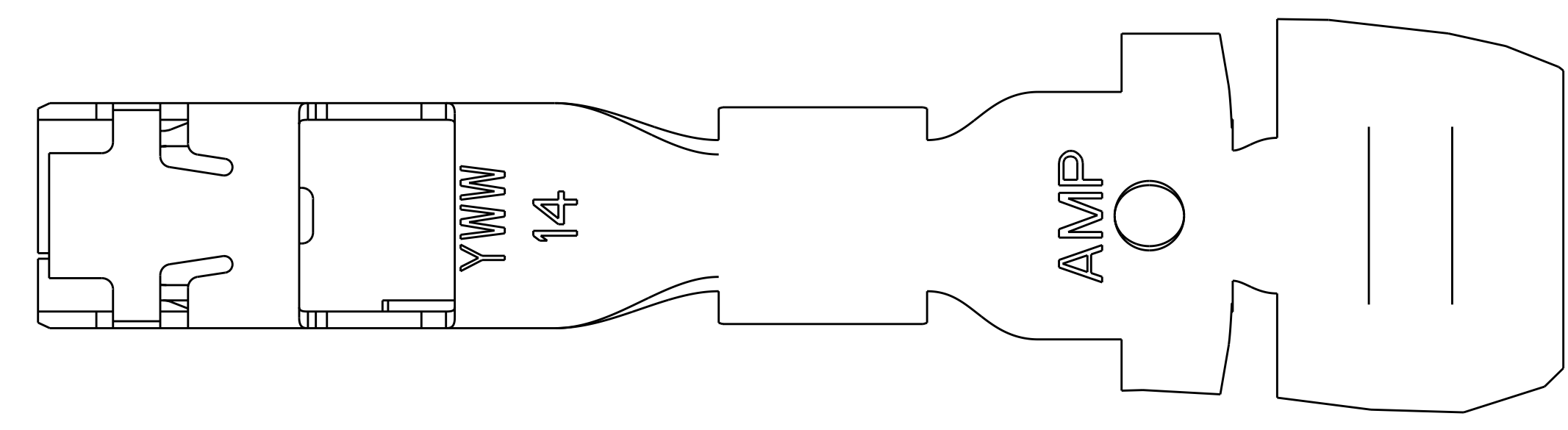

- 1 MATERIAL: 0.30 THICK COPPER ALLOY, PREPLATED WITH 0.0008 MINIMUM THICK REFLOW TIN OR BRIGHT TIN. (ELV COMPLIANT)  
 ALTERNATE MATERIAL: 0.30 THICK COPPER ALLOY, PREPLATED WITH 0.0008 MINIMUM THICK BRIGHT TIN (ELV COMPLIANT).
- 2. QUALIFICATION OF THE CRIMP APPLICATION TOOLING SHALL BE CONTROLLED BY THE REQUIREMENTS ESTABLISHED UNDER USCAR 21.
- 3 LUBRICANT, NYE UNIFLOR 8917, ADDED TO INTERIOR OF RECEPTACLE BOX. QUANTITY SUFFICIENT TO COAT INTERIOR BEAM AND ALLOWING FOR SOME RESIDUAL PASTE TO RESIDE INSIDE. SEEPAGE FROM BOX OPENINGS ALLOWED.

STATUS	LUBRICANT	REELING	N	L	ØK	J	H	ØF	E	WIRE SIZE	PART NUMBER
NOT RELEASED										12 AWG	1-776546-2
RELEASED										14 AWG	1-776546-1
NOT RELEASED										16 AWG	1-776546-0
NOT RELEASED										18 AWG	776546-9
NOT RELEASED										20 AWG	776546-8
RELEASED										22 AWG	776546-7
NOT RELEASED										12 AWG	776546-6
RELEASED										14 AWG	776546-5
NOT RELEASED										16 AWG	776546-4
NOT RELEASED										18 AWG	776546-3
NOT RELEASED										20 AWG	776546-2
RELEASED										22 AWG	776546-1

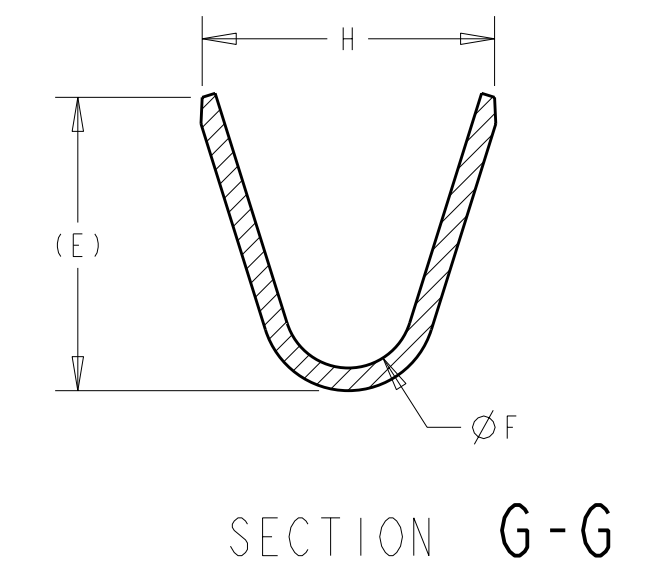
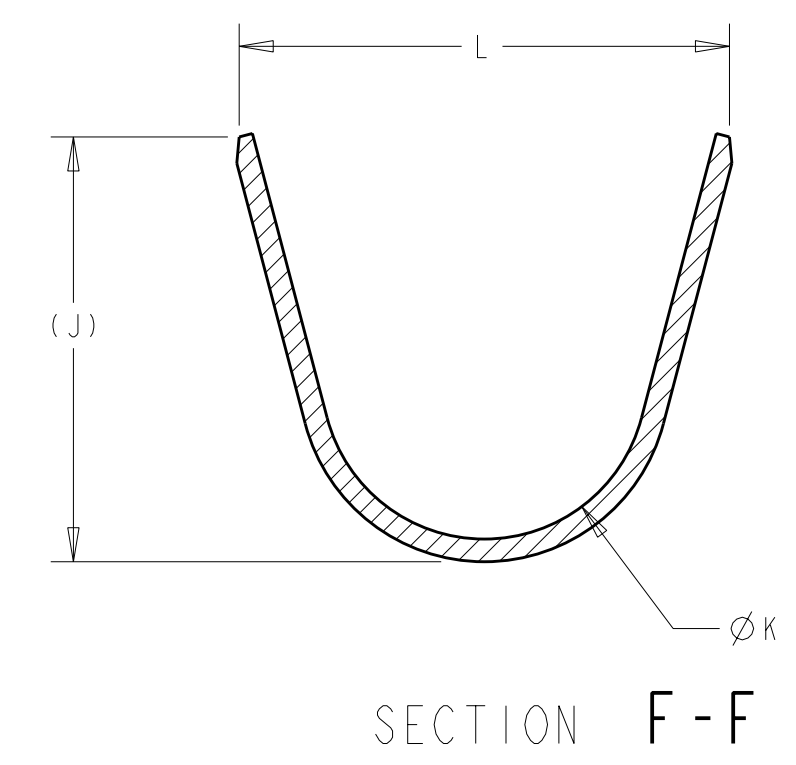
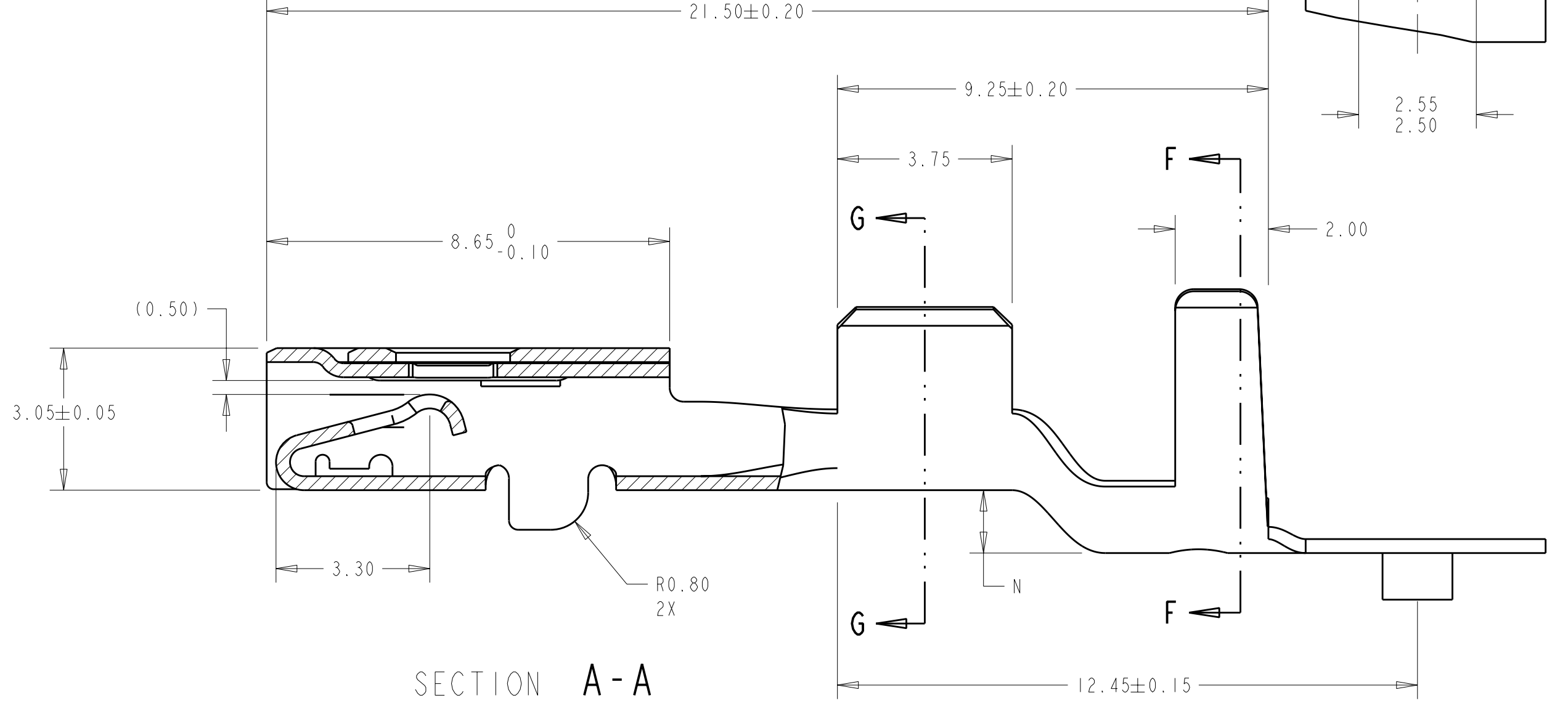
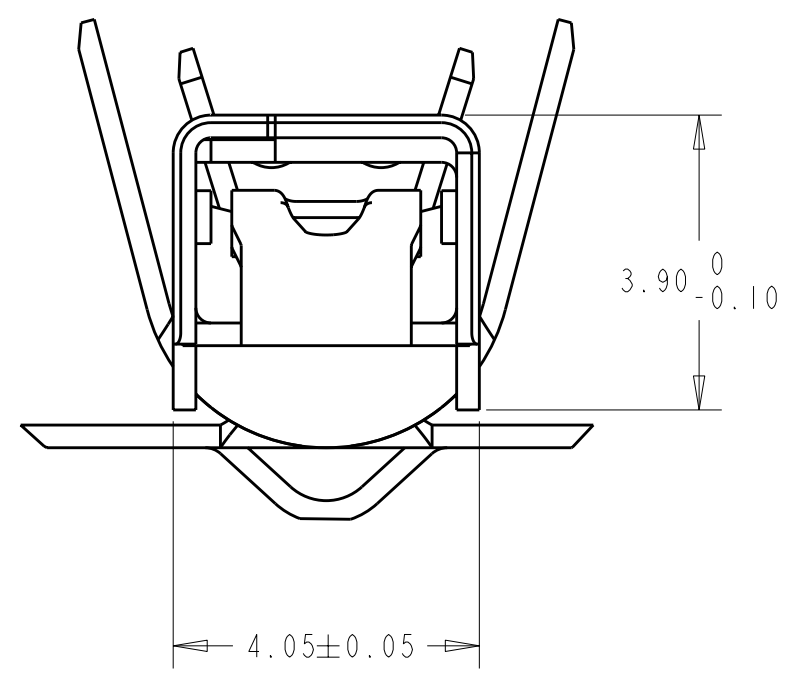
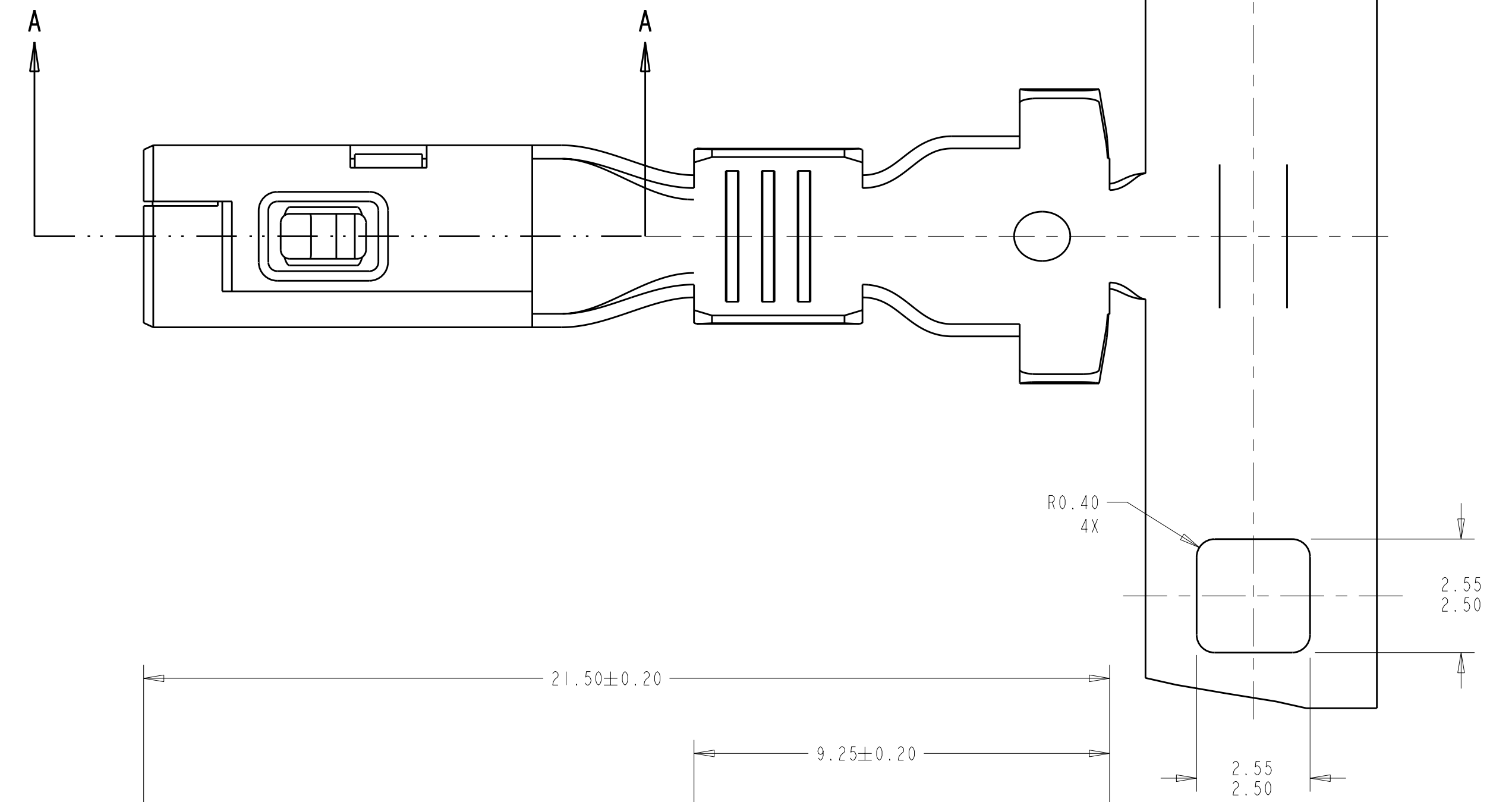
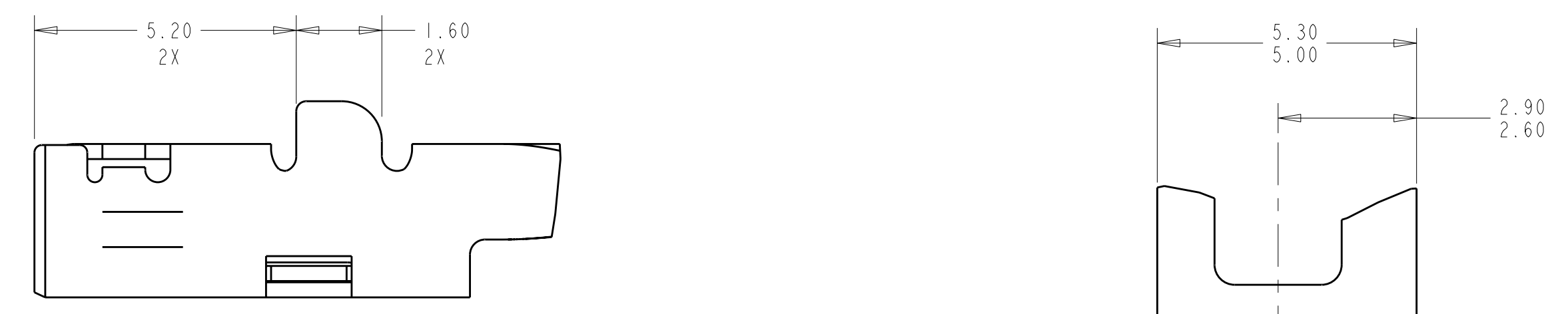
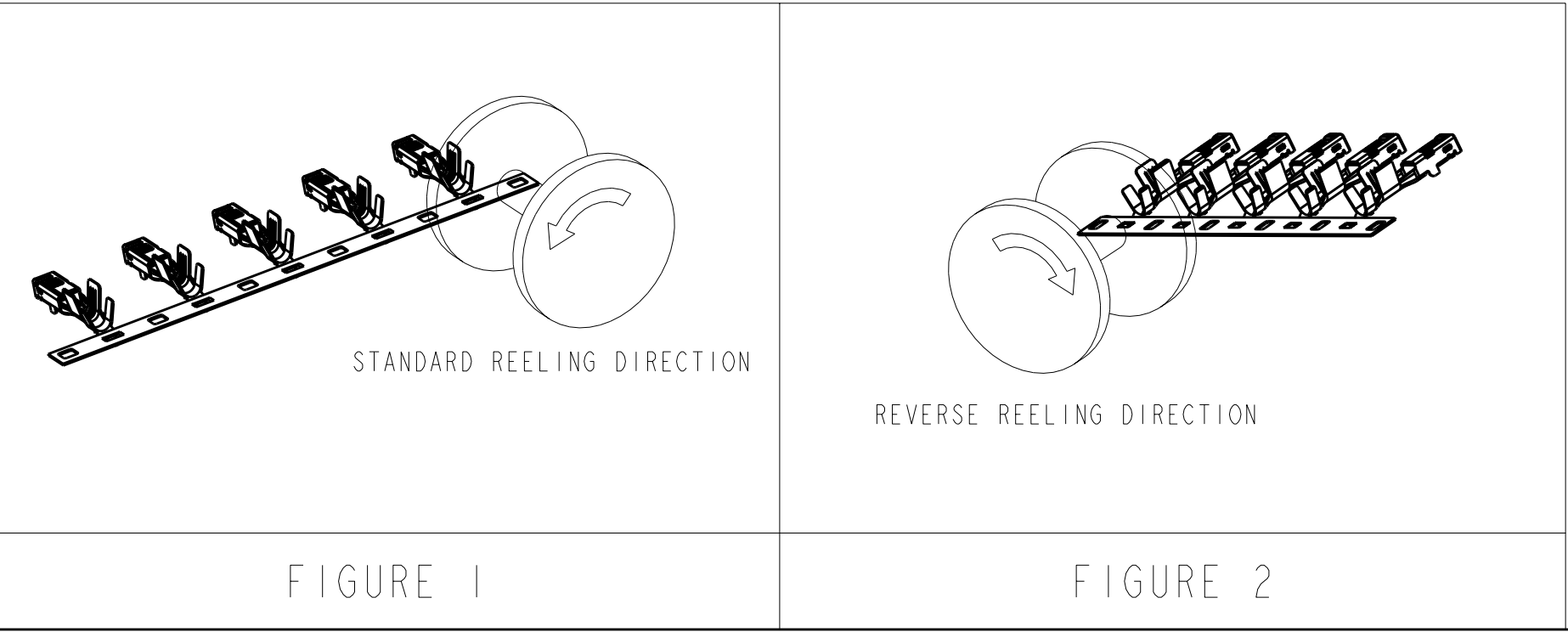

DIMENSIONS: mm  
 TOLERANCES UNLESS OTHERWISE SPECIFIED:  
 9 PLC ±.3  
 1 PLC ±0.10  
 5 PLC ±.1  
 4 PLC ±.1  
 ANGLES ±4°  
 MATERIAL: FINISH:

DWN: D. DRUMMOND 16NOV2009  
 CHK: S. MANKARYOS 16NOV2009  
 APVD: S. MANKARYOS 16NOV2009  
 PRODUCT SPEC: SAE/USCAR-2 8/97  
 APPLICATION SPEC: 114-13013  
 WEIGHT: -  
 CUSTOMER DRAWING

Tyco Electronics  
 Harrisburg, PA 17105-3608  
 NAME: 2.8mm RECEPTACLE WITH LUBRICATION, SEALED  
 SIZE: 114-13013  
 CAGE CODE: A1100779  
 DRAWING NO: C-776546  
 SCALE: 10:1 SHEET 1 OF 1 REV A