

SERIES 801 DOUBLE-START ACME THREAD Mighty Mouse Connectors and Cables



Receptacles with Rear-Release Crimp Contacts with Banding Porch or Accessory Threads



Series 801 Mighty Mouse Receptacle Connector features a double-start modified stub ACME mating thread for improved protection against cross-mating and thread damage. Connector shells are machined aluminum or stainless steel. Supplied with crimp contacts, packaged separately. Terminate contacts with standard M22520 tools. Metal clips inside the connector body lock contact into place. Contacts are removable. Fluorosilicone seals and rear grommet protect connector from water ingress. Terminate cable shield directly to band platform with Band-Master™ ATS strap or choose rear accessory thread to attach optional cable clamp or backshell. Available in shell sizes 5 through 21 with 67 contact arrangements.

How To Order

Sample Part Number	801-010	-02	Z1	16-55	S	A
Series (See Table I)	801-009 = Receptacle with Banding Platform 801-010 = Receptacle with Accessory Thread					
Shell Style (See Table II)	-01 = In-Line Cable Receptacle -02 = Square Flange, Front or Rear Panel Mount with Thru-Holes -12 = Square Flange, Rear Panel Mount with "Non-Locking" Clinch Nuts -22 = Square Flange, Rear Panel Mount with "Locking" Clinch Nuts -07 = Jam-Nut, Rear Panel Mount					
Material and Finish	M = Aluminum / Electroless Nickel MT = Aluminum / Nickel-PTFE NF = Aluminum / Cadmium with Olive Drab Chromate ZNU = Aluminum / Zinc-Nickel with Black Chromate Z1 = Stainless Steel / Passivated					
Shell Size - Insert Arr	See Contact Arrangements page E-7					
Contact Type	Connector supplied with contacts P = Pin S = Socket Connectors with contacts are supplied with crimp contacts. Contacts not installed. For coax contacts, order contacts separately and request pin or socket connector without contacts.		Connector supplied without contacts A = Pin Connector B = Socket Connector		Connector supplied with size 30 AWG contacts G = #23 Pin H = #23 Socket	
Polarization (See Table III)	A = Normal B = Pos. B C = Pos. C D = Pos. D E = Pos. E F = Pos. F					

Table I: Series

801-009 Banding Platform	801-010 Rear Accessory Thread

Table II: Shell Style

Style -01 In-line	Style -02/-12/-22 Square Flange	Style -07 Jam-Nut

Table III: Keyway Positions

Position	A°	B°
A	150°	210°
B	75°	210°
C	95°	230°
D	140°	275°
E	75°	275°
F	95°	210°

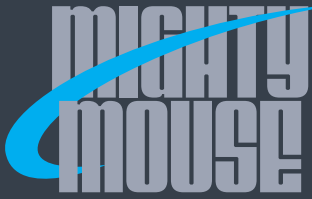

In-Line Receptacle with Crimp Contacts with Banding Porch or Accessory Threads

IN-LINE RECEPTACLE - SHELL STYLE 01

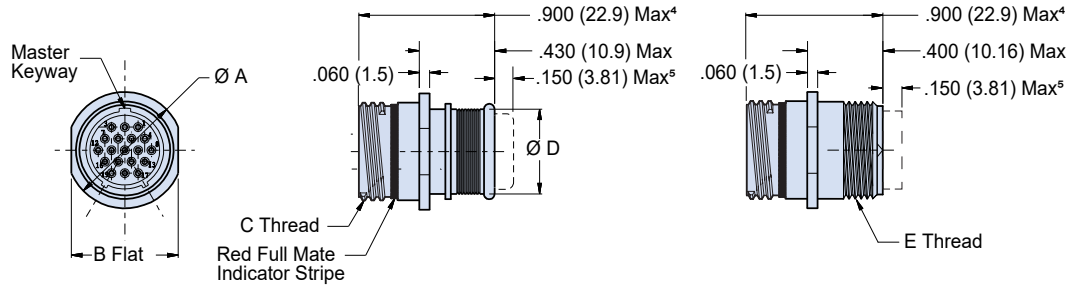

Integral Band Platform
801-009-01

Accessory Thread
801-010-01

Dimensions					
Shell Size	Ø A	B Flat	C Thread	Ø D	E Thread UNEF-2A
5	.355 (9.02)	.325 (8.25)	.3125-.05P-.1L-DS-2A	.245 (6.22)	.2500-32
6	.415 (10.54)	.385 (9.78)	.3750-.05P-.1L-DS-2A	.290 (7.37)	.3125-32
7	.480 (12.19)	.445 (11.30)	.4375-.05P-.1L-DS-2A	.390 (9.91)	.4375-28
8	.540 (13.72)	.510 (12.95)	.5000-.05P-.1L-DS-2A	.445 (11.30)	.5000-28
9	.605 (15.37)	.575 (14.60)	.5625-.05P-.1L-DS-2A	.500 (12.70)	.5625-24
10	.665 (16.89)	.635 (16.13)	.6250-.05P-.1L-DS-2A	.560 (14.22)	.6250-24
11	.730 (18.54)	.700 (17.78)	.6875-.05P-.1L-DS-2A	.605 (15.37)	.6875-24
13	.855 (21.72)	.825 (20.96)	.8125-.1P-.2L-DS-2A	.650 (16.51)	.6875-24
16	1.040 (26.42)	1.010 (25.65)	1.0000-.1P-.2L-DS-2A	.805 (20.45)	.9375-20
17	1.110 (28.19)	1.070 (27.18)	1.0625-.1P-.2L-DS-2A	.850 (21.59)	.9375-20
19	1.243 (31.57)	1.191 (30.25)	1.1875-.1P-.2L-DS-2A	1.003 (25.48)	1.0625-18
21	1.375 (34.92)	1.312 (33.32)	1.3125-.1P-.2L-DS-2A	1.110 (28.19)	1.1875-18

NOTES

- Contacts are crimp type, and used in a rear release retention system
- Receptacle mates with all quick coupling high density receptacle connectors with same polarization and opposite contact gender
- Connectors supplied with standard crimp contacts. For coax or other special contacts, order connector less contacts (Contact style A or B) and order contacts separately
- For all insert arrangements with size #8 contacts add .235" to overall length of 801-010 and .340" to 801-009 overall length
- Grommet protrudes for power/combo size #8 arrangements
- Material / finish:
 - Shell, jam-nut: aluminum alloy or CRES; see How to Order Table
 - Insulator: high grade rigid dielectric / N.A.
 - Interfacial seal, O-rings, grommet: fluorosilicone / N.A.
 - Contact: copper alloy / gold plate per ASTM B 488, Type II, Code C, Class 1.25, over a suitable underplate

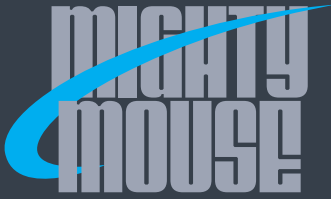

SERIES 801 DOUBLE-START ACME THREAD Mighty Mouse Connectors and Cables



Square Flange Receptacle with Crimp Contacts with Banding Porch or Accessory Threads

SQUARE FLANGE, FRONT OR REAR PANEL MOUNT RECEPTACLE - SHELL STYLE 02

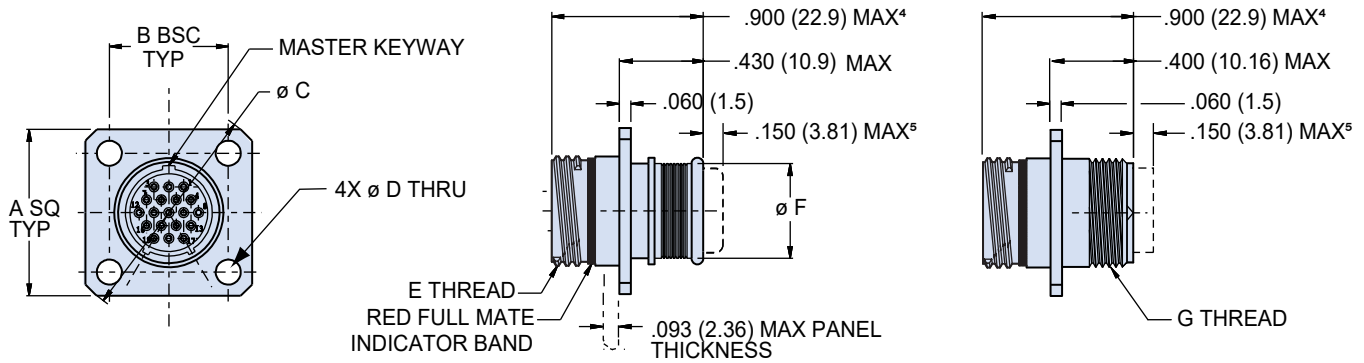

Integral Band Platform
801-009-02

Accessory Thread
801-010-02

Dimensions							
Shell Size	A SQ	B BSC	Ø C	Ø D	E Thread	Ø F	G Thread UNEF-2A
5	.530 (13.46)	.363 (9.22)	.680 (17.27)	.096 (2.44) .091 (2.31)	.3125-.05P-.1L-DS-2A	.245 (6.22)	.2500-32
6	.590 (14.99)	.423 (10.74)	.750 (19.05)		.3750-.05P-.1L-DS-2A	.290 (7.37)	.3125-32
7	.650 (16.51)	.483 (12.27)	.850 (21.59)		.4375-.05P-.1L-DS-2A	.390 (9.91)	.4375-28
8	.712 (18.08)	.545 (13.84)	.938 (23.83)		.5000-.05P-.1L-DS-2A	.445 (11.30)	.5000-28
9	.850 (21.59)	.607 (15.42)	1.125 (28.58)	.130 (3.30) .126 (3.20)	.5625-.05P-.1L-DS-2A	.500 (12.70)	.5625-24
10	.890 (22.61)	.670 (17.02)	1.188 (30.18)		.6250-.05P-.1L-DS-2A	.560 (14.22)	.6250-24
11	.935 (23.75)	.715 (18.16)	1.250 (31.75)		.6875-.05P-.1L-DS-2A	.605 (15.37)	.6875-24
13	1.030 (26.16)	.812 (20.62)	1.375 (34.92)		.8125-.1P-.2L-DS-2A	.650 (16.51)	.6875-24
16	1.219 (30.96)	.981 (24.92)	1.625 (41.28)		1.0000-.1P-.2L-DS-2A	.805 (20.45)	.9375-20
17	1.280 (32.51)	1.060 (26.92)	1.700 (43.18)		1.0625-.1P-.2L-DS-2A	.850 (21.59)	.9375-20
19	1.432 (36.37)	1.191 (30.25)	1.900 (48.26)		1.1875-.1P-.2L-DS-2A	1.003 (25.48)	1.0625-18
21	1.565 (39.75)	1.322 (33.58)	2.100 (53.34)		1.3125-.1P-.2L-DS-2A	1.110 (28.19)	1.1875-18

NOTES

- See page E-11 for rear panel cut-out dimensions
- Material / finish:
 - Shell: aluminum alloy or CRES; see How to Order Table
 - Insulator: high grade rigid dielectric / N.A.
 - Interfacial seal, O-rings, grommet: fluorosilicone / N.A.
 - Contact: copper alloy / gold plate per ASTM B 488, Type II, Code C, Class 1.25, over a suitable underplate

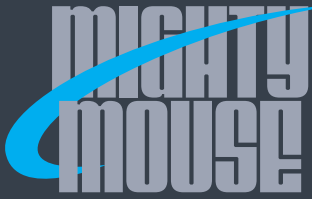

Jam-Nut Receptacle with Crimp Contacts with Banding Porch or Accessory Threads

JAM-NUT, REAR PANEL MOUNT RECEPTACLE - SHELL STYLE 07

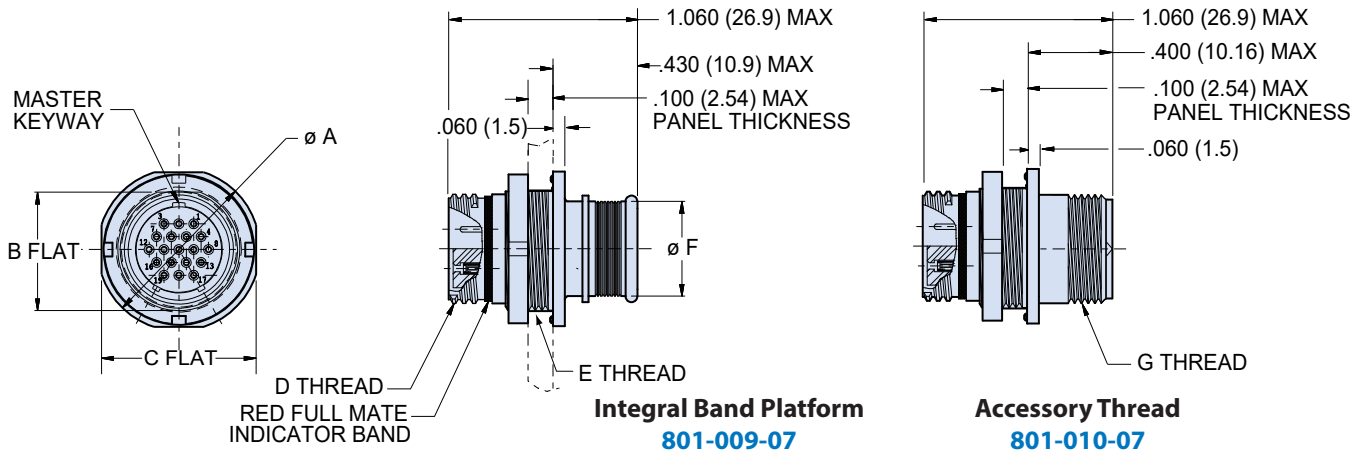

Dimensions							
Shell Size	ϕA	B Flat	C Flat	D Thread	E Thread UN-2A	ϕF	G Thread UN-2A
5	.575 (14.60)	.350 (8.89)	.545 (13.84)	.3125-.05P-.1L-2A	.375-28	.245 (6.22)	.250-32
6	.635 (16.13)	.410 (10.41)	.595 (15.11)	.375-.05P-.1L-2A	.4375-28	.290 (7.37)	.3125-32
7	.755 (19.18)	.536 (13.61)	.723 (18.36)	.4375-.05P-.1L2A	.5625-32	.390 (9.91)	.4375-28
8	.755 (19.18)	.536 (13.61)	.723 (18.36)	.5000-.05P-.1L-2A	.5625-32	.445 (11.30)	.5000-28
9	.830 (21.08)	.596 (15.14)	.790 (20.07)	.5625-.05P-.1L-2A	.625-28	.500 (12.70)	.5625-24
10	.890 (22.61)	.658 (16.71)	.855 (21.72)	.6250-.05P-.1L-2A	.6875-28	.560 (14.22)	.6250-24
11	.960 (24.38)	.718 (18.24)	.925 (23.50)	.6875-.05P-.1L-2A	.7500-28	.605 (15.37)	.6875-24
13	1.078 (27.38)	.845 (21.46)	1.044 (26.52)	.8125-.1P-.2L-2A	.875-28	.650 (16.51)	.6875-24
16	1.264 (32.11)	1.022 (25.96)	1.230 (31.24)	1.000-.1P-.2L-2A	1.0625-20	.805 (20.45)	.9375-20
17	1.325 (33.65)	1.096 (27.84)	1.290 (32.77)	1.062-.1P-.2L-2A	1.125-28	.850 (21.59)	.9375-20
19	1.450 (36.83)	1.227 (31.17)	1.415 (35.94)	1.1875-.1P-.2L-2A	1.2500-28	1.003 (25.48)	1.0625-18
21	1.625 (41.28)	1.347 (34.21)	1.577 (40.06)	1.3125-.1P-.2L-2A	1.375-28	1.110 (28.19)	1.1875-18

NOTES

- See page E-11 for panel cut-out dimensions
- Material / finish:
 - Shell, jam-nut: aluminum alloy or CRES; see How to Order Table
 - Insulator: high grade rigid dielectric / N.A.
 - Interfacial seal, O-rings, grommet: fluorosilicone / N.A.
 - Contact: copper alloy / gold plate per ASTM B 488, Type II, Code C, Class 1.25, over a suitable underplate

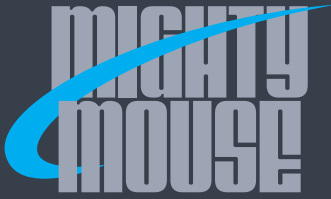

SERIES 801 DOUBLE-START ACME THREAD Mighty Mouse Connectors and Cables



Rear Panel Mount Receptacles with Clinch Nuts and Banding Porch or Accessory Threads

REAR PANEL MOUNT RECEPTACLES - SHELL STYLE 12 (NON-LOCKING CLINCH NUTS) AND 22 (LOCKING CLINCH NUTS)

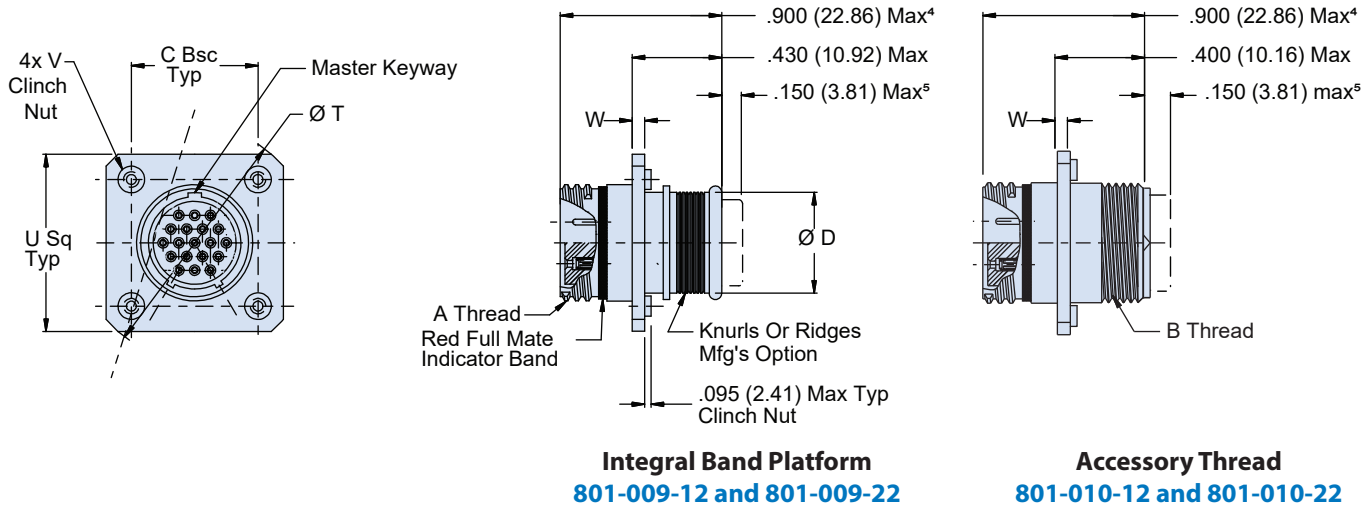

Dimensions							
Shell Size	A Thread	B Thread	C BSC	Ø T	U SQ	V Clinch Nut	W
5	.3125-.05P-.1L-DS-2A	.2500-32 UNEF-2A	.363 (9.22)	.774 (19.66)	.623 (15.82)	2-56	.030 (0.76)
6	.3750-.05P-.1L-DS-2A	.3125-32 UNEF-2A	.423 (10.74)	.860 (21.84)	.683 (17.35)		
7	.4375-.05P-.1L-DS-2A	.4375-28 UNEF-2A	.483 (12.27)	.944 (23.98)	.743 (18.87)		
8	.5000-.05P-.1L-DS-2A	.5000-28 UNEF-2A	.545 (13.84)	1.032 (26.21)	.805 (20.45)		
9	.5625-.05P-.1L-DS-2A	.5625-24 UNEF-2A	.607 (15.42)	1.180 (29.97)	.927 (23.55)	4-40	.060 (1.52)
10	.6250-.05P-.1L-DS-2A	.6250-24 UNEF-2A	.670 (17.02)	1.268 (32.21)	.990 (25.15)		
11	.6875-.05P-.1L-DS-2A	.6875-24 UNEF-2A	.715 (18.16)	1.331 (33.81)	1.035 (26.29)		
13	.8125-.1P-.2L-DS-2A	.6875-24 UNEF-2A	.812 (20.62)	1.470 (37.34)	1.132 (28.75)		
16	1.0000-.1P-.2L-DS-2A	.9375-20 UNEF-2A	.981 (24.92)	1.708 (43.38)	1.301 (33.05)		
17	1.0625-.1P-.2L-DS-2A	.9375-20 UNEF-2A	1.060 (26.92)	1.822 (46.28)	1.382 (35.10)		
19	1.1875-.1P-.2L-DS-2A	1.0625-18 UNEF-2A	1.191 (30.25)	2.006 (50.95)	1.511 (38.38)		
21	1.3125-.1P-.2L-DS-2A	1.1875-18 UNEF-2A	1.322 (33.58)	2.190 (55.63)	1.642 (41.71)		

NOTES

- See page E-11 for panel cut-out dimensions
- Material / finish:
 - Shell: aluminum alloy or CRES; see How to Order Table
 - Insulator: high grade rigid dielectric / N.A.
 - Interfacial seal, O-rings, grommet: fluorosilicone / N.A.
 - Contact: copper alloy / gold plate per ASTM B 488, Type II, Code C, Class 1.25, over a suitable underplate

SERIES 801 DOUBLE-START MATING