

# FTLF8546P4BCV

## 16GFC, 10GE RoHS Compliant Short Wavelength SFP+ Transceiver

FTLF8546P4BCV SFP+ transceivers are designed for use in Fibre Channel links up to 14.025 Gb/s data rate over multimode fiber. They are compliant with FC-PI-5 Rev. 6.00a, SFF-8472 Rev 11.0c and SFF-8081h, and compatible with SFF-8432b and applicable portions of SFF-8431 Rev. 4.1d. The transceiver is RoHS compliant as described in Application Note AN-2038.



### FEATURES

- Up to 14.025 Gb/s 10Gb/s bi-directional data links
- Hot-pluggable SFP+ footprint
- Built-in digital diagnostic functions
- 850nm Oxide VCSEL laser transmitter
- Duplex LC connector
- RoHS compliant
- 35m on 50/125 $\mu$ m (OM2) MMF
- 100m over M5E MMF (50/125 $\mu$ m OM3)
- Metal enclosure, for lower EMI
- Single 3.3V power supply
- Operating temperature range: 0°C to 70°C

### APPLICATIONS

- 14.025 Gb/s Fibre Channel
- 10.3Gb/s Gigabit Ethernet

Product Selection

**FTLF8546P4BCV**

I. Pin Descriptions

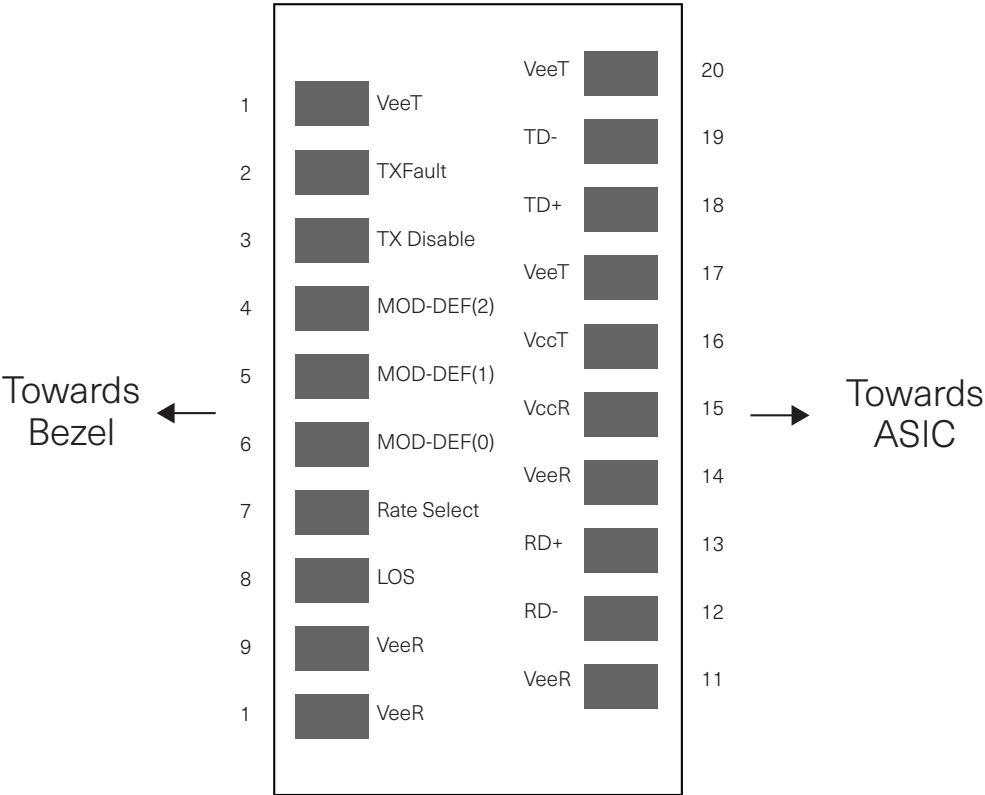

Diagram of Host Board Connector Block Pin Numbers and Names

Pin	Symbol	Name/Description	Notes
1	V <sub>EET</sub>	Transmitter Ground (Common with Receiver Ground)	1
2	T <sub>FAULT</sub>	Transmitter Fault.	2
3	T <sub>DIS</sub>	Transmitter Disable. Laser output disabled on high or open.	3
4	SDA	2-wire Serial Interface Data Line (MOD-DEF2)	4
5	SCL	2-wire Serial Interface Clock (MOD-DEF1)	4
6	MOD_ABS	Module Absent, connected to VEET or VEER	4
7	RS0	Rx Rate Select: Open or Low = 10 Gb/s GE Lite or 8G/4.25G Fibre Channel (Low Bandwidth) High = 14.025 Gb/s Fibre Channel (High Bandwidth)	5
8	RX_LOS	Loss of Signal indication. Logic 0 indicates normal operation.	6
9	RS1	Tx Rate Select: Open or Low = 10 Gb/s GE Lite or 8G/4.25G Fibre Channel (Low Bandwidth) High = 14.025 Gb/s Fibre Channel (High Bandwidth)	5
10	V <sub>EER</sub>	Receiver Ground (Common with Transmitter Ground)	1
11	V <sub>EER</sub>	Receiver Ground (Common with Transmitter Ground)	1
12	RD-	Receiver Inverted DATA out. AC Coupled	
13	RD+	Receiver Non-inverted DATA out. AC Coupled	
14	V <sub>EER</sub>	Receiver Ground (Common with Transmitter Ground)	1
15	V <sub>CCR</sub>	Receiver Power Supply	
16	V <sub>CCT</sub>	Transmitter Power Supply	
17	V <sub>EET</sub>	Transmitter Ground (Common with Receiver Ground)	1
18	TD+	Transmitter Non-Inverted DATA in. AC Coupled.	
19	TD-	Transmitter Inverted DATA in. AC Coupled.	
20	V <sub>EET</sub>	Transmitter Ground (Common with Receiver Ground)	1

## Notes

- Circuit ground is internally isolated from chassis ground.
- T<sub>FAULT</sub> is an open collector/drain output, which should be pulled up with a 4.7k – 10k Ohms resistor on the host board if intended for use. Pull up voltage should be between 2.0V to V<sub>cc</sub> + 0.3V. A high output indicates a transmitter fault caused by either the TX bias current or the TX output power exceeding the preset alarm thresholds. A low output indicates normal operation. In the low state, the output is pulled to <0.8V.
- Laser output disabled on T<sub>DIS</sub> >2.0V or open, enabled on T<sub>DIS</sub> <0.8V.
- Should be pulled up with 4.7k – 10kohms on host board to a voltage between 2.0V and 3.6V. MOD\_ABS pulls line low to indicate module is plugged in.
- Rate select can also be set through the 2-wire bus in accordance with SFF-8472 v. 12.1c. Rx Rate Select is set at Bit 3, Byte 110, Address A2h. Tx Rate Select is set at Bit 3, Byte 118, Address A2h. Note: writing a "1" selects maximum bandwidth operation. Rate select is the logic OR of the input state of Rate Select Pin and 2-wire bus.
- LOS is open collector output. Should be pulled up with 4.7k – 10kohms on host board to a voltage between 2.0V and 3.6V. Logic 0 indicates normal operation; logic 1 indicates loss of signal

## II. Absolute Maximum Ratings

Parameter	Symbol	Min	Typ	Max	Unit	Ref.
Maximum Supply Voltage	V <sub>cc</sub>	-0.5		4.0	V	
Storage Temperature	T <sub>s</sub>	-40		85	°C	
Case Operating Temperature	T <sub>c</sub>	0		70	°C	
Relative Humidity (Non-condensing)	RH	0		85	%	1

## Notes:

- Non Condensing

### III. Electrical Characteristics ( $T_A$ , $V_{CC} = 3.15$ to $3.46$ Volts)

Parameter	Symbol	Min	Typ	Max	Unit	Ref.
Supply Voltage	$V_{CC}$	3.15		3.46	V	
Supply Current	$I_{CC}$			290	mA	1
<b>Transmitter</b>						
Input differential impedance	$R_{in}$		100		$\Omega$	2
Differential data input swing	$V_{in,pp}$	90		800	mV	
Transmit Disable Voltage	$V_D$	2		$V_{CC}$	V	3
Transmit Enable Voltage	$V_{EN}$	Vee		Vee + 0.8	V	
<b>Receiver</b>						
Single ended data output swing	$V_{out,pp}$	185		425	mV	4
LOS Fault	$V_{LOS\ fault}$	2		$V_{CC_{HOST}}$	V	5
LOS Normal	$V_{LOS\ norm}$	Vee-0.0		Vee+0.4	V	5
Power Supply Rejection	PSR	100			mVpp	6
Deterministic Jitter 8.5 Gb/s 14.025Gb/s	RX DJ			0.420 0.220	UI	
Total Jitter @ 10.3Gb/s	J2			68	ps	

#### Notes:

1. With established link. The total power dissipation could exceed 1W when the module is trying to establish link at operating case temperature below 25oC
2. Connected directly to TX data input pins. AC coupling from pins into laser driver IC.
3. Or open circuit.
4. Into 100 ohms differential termination.
5. LOS is an open collector output. Should be pulled up with 4.7k – 10kohms on the host board. Normal operation is logic 0; loss of signal is logic 1. Maximum pull-up voltage is 5.5V.
6. Receiver sensitivity is compliant with power supply sinusoidal modulation of 20 Hz to 1.5 MHz up to specified value applied through the recommended power supply filtering network.

IV. Optical Characteristics ( $T_A$ ,  $V_{CC} = 3.15$  to  $3.46$  Volts)

Parameter	Symbol	Min	Typ	Max	Unit	Ref.
<b>Transmitter</b>						
Average Output Power: 50 or 62.5 MMF	$P_{OUT}$	-7.8			dBm	1
Optical Wavelength	$\lambda_c$	840		860	nm	
Spectral Width (RMS), 28.05Gb/s	$\sigma$			0.59	nm	
Optical Modulation Amplitude 4.25Gb/s 8.5 Gb/s and 10.3 Gb/s 14.025Gb/s	OMA	247 (-6.1) 302 (-5.2) 331 (-4.8)			$\mu$ W	
Transmitter Dispersion Penalty @ 10.3 Gb/s	TDP			2.5	dB	2
Transmitter Waveform and Dispersion Penalty, 8.5 Gb/s	TWDP			4.3	dB	3
Vertical Eye Closure Penalty 14.025 Gb/s	CEVPQ			2.56	dB	4
Relative Intensity Noise	RIN			-128	dB/Hz	
<b>Receiver</b>						
Unstressed Receiver OMA Sensitivity 4.25Gb/s 8.5 Gb/s 14.025Gb/s	$Rx_{SENS}$			61(-12.1) 76(-11.2) 89(-10.5)	$\mu$ W (dBm)	5
Unstressed Receiver OMA Sensitivity = 10.3 Gb/s	$Rx_{SENS}$			-11.1	dBm	
Stressed Receiver Sensitivity (OMA) @ 10.3Gb/s	$Rx_{SENS2}$			-7.5	dBm	5
Average Receiver Power	$Rx_{MAX}$	0			dBm	
Optical Center Wavelength	$\lambda_c$	770		860	nm	
Optical Return Loss		12			dB	
LOS De-Assert	$LOS_D$			-13	dBm	
LOS Assert	$LOS_A$	-30			dBm	
LOS Hysteresis		0.5			dB	

## Notes:

- Class 1 Laser Safety limit per FDA/CDRH, and EN (IEC) 60825 laser safety standards.
- The TDP transversal filter should be scaled from SR: for 100m OM3 and 0.65nm spectral bandwidth the TDP filter should have tap separation of 21 ps. This would introduce ~0.3dB eye closure penalty
- TWDP is calculated with a 1,0 equalizer and a 9.84 GHz Gaussian filter for the fiber simulation. Jitter values at  $\gamma_T$  and  $\gamma_R$  are controlled by TWDP and stress receiver sensitivity.
- For 16GFC, VECPQ is calculated with a 16.6 GHz Gaussian filter for fiber simulation
- Unstressed Rx sensitivity

## V. General Specifications

Parameter	Symbol	Min	Typ	Max	Unit	Ref.
Bit Rate	BR		4.25 8.5 10.3 14.025		Gb/sec	1
Bit Error Rate	BER			$10^{-12}$		2
Fiber Length on 50/125 $\mu$ m (OM2/M5) MMF	L			150 50 35	m	3 4 5
Fiber Length on 50/125 $\mu$ m high-bandwidth (OM3/M5E) MMF	L			380 150 100	m	3 4 5

Notes:

1. 8x Fibre Channel compatible, per FC-P1-4<sup>1</sup>.
2. PRBS 2<sup>7</sup>-1 for 8GFC. PRBS 2<sup>31</sup>-1 for 16GFC
3. At 4.25 Gb/s Fibre Channel data rate
4. At 8.5 Gb/s Fibre Channel data rate.
5. At 14.025 Gb/s Fibre Channel and 10.3Gb/s data rate.

## VII. Environmental Specifications

Environmental Specifications	Symbol	Min	Typ	Max	Units	Ref.
Case Operating Temperature	T <sub>op</sub>	0		70	°C	
Storage Temperature	T <sub>sto</sub>	-40		85	°C	

## VII. Regulatory Compliance

Finisar transceivers are Class 1 Laser Products and comply with US FDA regulations. These products are certified by TÜV and CSA to meet the Class 1 eye safety requirements of EN (IEC) 60825 and the electrical safety requirements of EN (IEC) 60950. Copies of certificates are available at Finisar Corporation upon request.

## VIII. Digital Diagnostic Functions

Finisar FTLF8529P4BCV SFP+ transceivers support the 2-wire serial communication protocol as defined in the SFP MSA<sup>f</sup>. It is very closely related to the E<sup>2</sup>PROM defined in the GBIC standard, with the same electrical specifications.

The standard SFP serial ID provides access to identification information that describes the transceiver's capabilities, standard interfaces, manufacturer, and other information.

Additionally, Finisar SFP transceivers provide an enhanced digital diagnostic monitoring interface, which allows real-time access to device operating parameters such as transceiver temperature, laser bias current, transmitted optical power, received optical power and transceiver supply voltage. It also defines a sophisticated system of alarm and warning flags, which alerts end-users when particular operating parameters are outside of a factory set normal range.

The SFP MSA defines a 256-byte memory map in E<sup>2</sup>PROM that is accessible over a 2-wire serial interface at the 8 bit address 1010000X (A0h). The digital diagnostic monitoring interface makes use of the 8 bit address 1010001X (A2h), so the originally defined serial ID memory map remains unchanged. The interface is identical to, and is thus fully backward compatible with both the GBIC Specification and the SFP Multi Source Agreement. The complete interface is described in Finisar Application Note AN-2030: "Digital Diagnostics Monitoring Interface for SFP Optical Transceivers".

The operating and diagnostics information is monitored and reported by a Digital Diagnostics Transceiver Controller (DDTC) inside the transceiver, which is accessed through a 2-wire serial interface. When the serial protocol is activated, the serial clock signal (SCL, Mod Def 1) is generated by the host. The positive edge clocks data into the SFP transceiver into those segments of the E<sup>2</sup>PROM that are not write-protected. The negative edge clocks data from the SFP transceiver. The serial data signal (SDA, Mod Def 2) is bi-directional for serial data transfer. The host uses SDA in conjunction with SCL to mark the start and end of serial protocol activation. The memories are organized as a series of 8-bit data words that can be addressed individually or sequentially.

For more information, please see the SFP MSA documentation<sup>c,f</sup> and Finisar Application Note AN- 2030.

## IX. Digital Diagnostic Specifications

FTLF8529P4BCV transceivers can be used in host systems that require either internally or externally calibrated digital diagnostics.

Parameter	Symbol	Units	Min	Max	Accuracy	Ref.
Transceiver temperature	D <sub>DDTemp</sub>	°C	0	+70	±5°C	
Transceiver supply voltage	D <sub>DDVoltage</sub>	V	3.14	3.45	±3%	
Transmitter bias current	D <sub>DDBias</sub>	mA	0	20	±10%	1
Transmitter output power	D <sub>DDTx-Power</sub>	dBm	-8	-1	±3dB	
Receiver average optical input power	D <sub>DDRx-Power</sub>	dBm	-12	0	±3dB	

Notes:

1. Accuracy of Measured Tx Bias Current is 10% of the actual Bias Current from the laser driver to the laser.

**X. Mechanical Specifications**

Finisar's FTLF8529P4BCV SFP+ transceivers are compatible with the SFF-8432b specification for improved pluggable form factor.

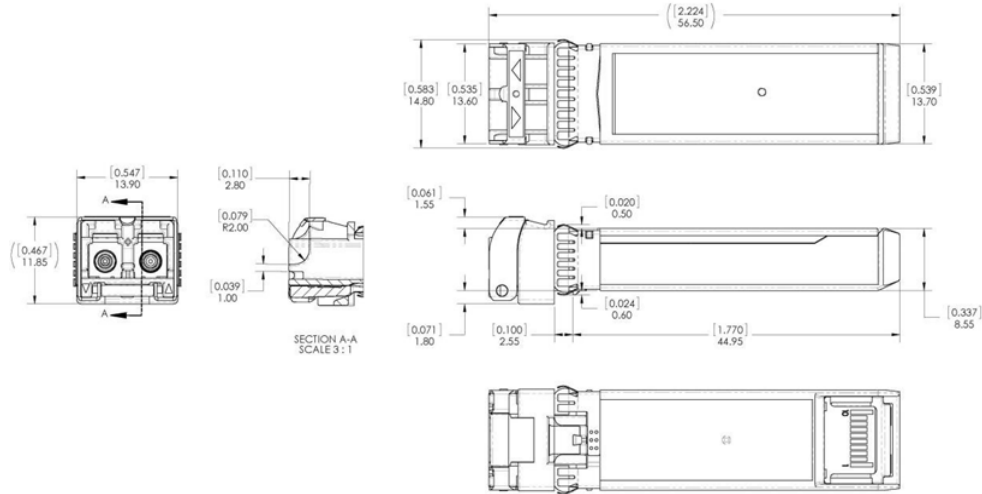

FTLF8529P4BCV



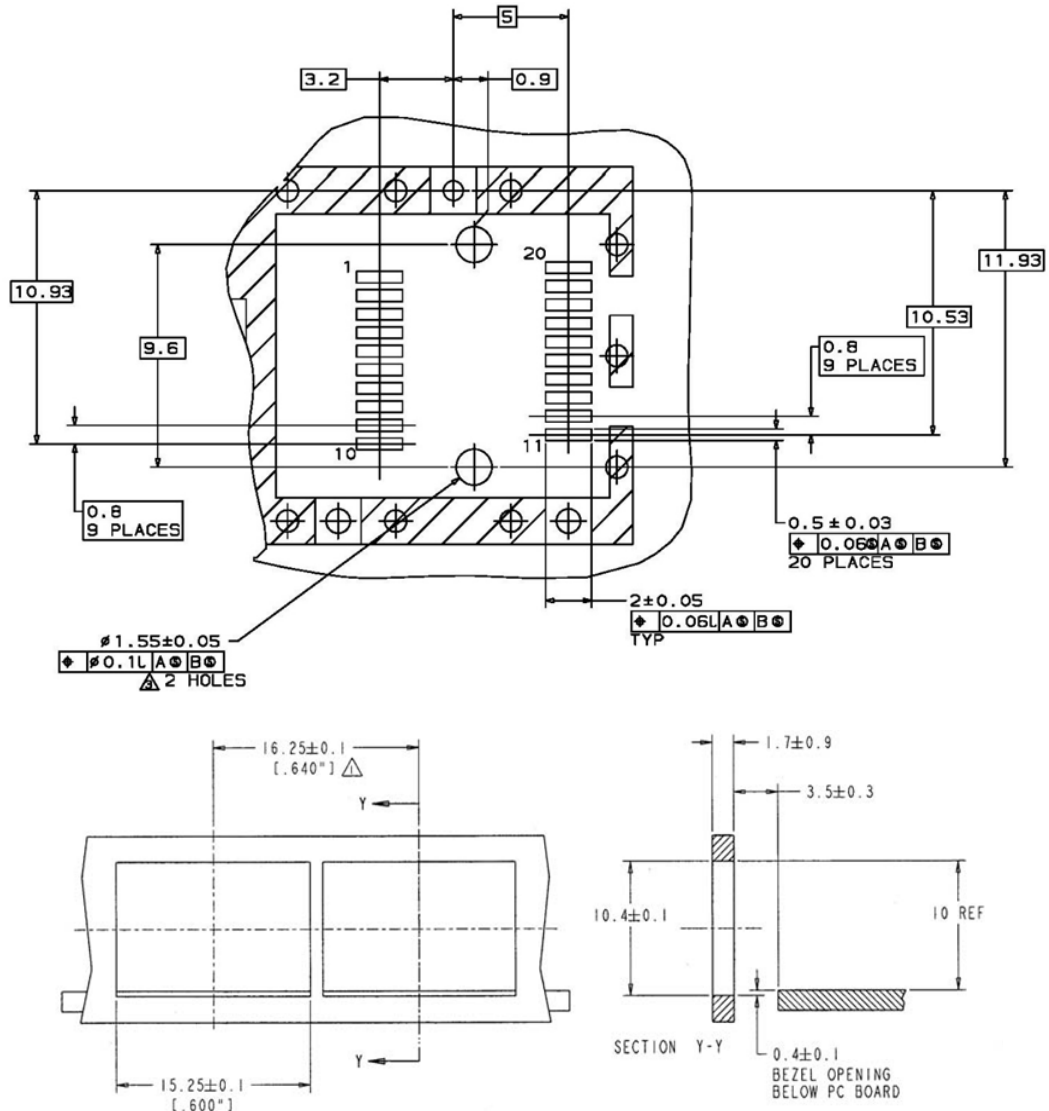

- NOTES:
- 1.  $\Delta$  MINIMUM PITCH ILLUSTRATED, ENGLISH DIMENSIONS ARE FOR REFERENCE ONLY
  - 2. NOT RECOMMENDED FOR PCI EXPANSION CARD APPLICATIONS

Figure 4.

**XI. References**

- a. "Fibre Channel – Physical Interfaces -5, INCITS 479-2011 (Defines 4GFC, 8GFC and 16GFC)
- b. "Improved Pluggable Form Factor", SFF Document Number SFF-8432, Revision 5.0, July 16, 2007.
- c. "Digital Monitoring Interface for Optical Transceivers", SFF Document Number SFF-8472, Revision 11.0.
- d. "Enhanced Small Form Factor Pluggable Module 'SFP+ '", SFF Document Number SFF-8431, Revision 4.1, July 6, 2009; Addendum Jun 21, 2013.
- e. Directive 2011/65/EU of the European Council Parliament and of the Council, "on the restriction of the use of certain hazardous substances in electrical and electronic equipment". 08-June 2011, which supercedes the previous ROHS Directive 2002/95/EC.
- f. Small Form Factor Pluggable (SFP) Transceiver Multi-source Agreement (MSA), September 14, 2000 which is available as SFF Document Number INF-8074, Revision 1.0 May 12, 2001
- g. "0.8mm Card Edge Connector for 16Gb/s Applications", SFF Document Number SFF-8081, Revision 0.2, December 21, 2009.
- h. SFF-8402, Revision 0.2