

Constant Current LED Driver with 64 Dimming Steps for up to 4 LEDs

BD1754HFN

General Description

BD1754HFN is a multi-level brightness control LED Driver that works as a constant current driver with 64 steps, so that the driving current can be adjusted finely. BD1754HFN is best suited to turn ON LEDs that require high-accuracy LED brightness control.

Features

- Current Regulation for up to 4 Parallel LEDs
- Adjustable Constant Current with 64 Steps
- High Accuracy and Good Matching of each Current Channel (0.5% Typ)
- Brightness Control Via Single-Line Digital Control Interface (Uni-Port Interface Control = UPIC)

Applications

This driver can be used in various applications such as mobile phones, portable game consoles and etc.

Key Specification

- Operating Power Supply Voltage Range: 2.7V to 5.5V
- Quiescent Current: 0.1 μ A (Typ)
- Operating Temperature Range: -30°C to +85 °C

Package

W(Typ) x D(Typ) x H(Max)



HSON8

2.90mm x 3.00mm x 0.60mm

Typical Application Circuit

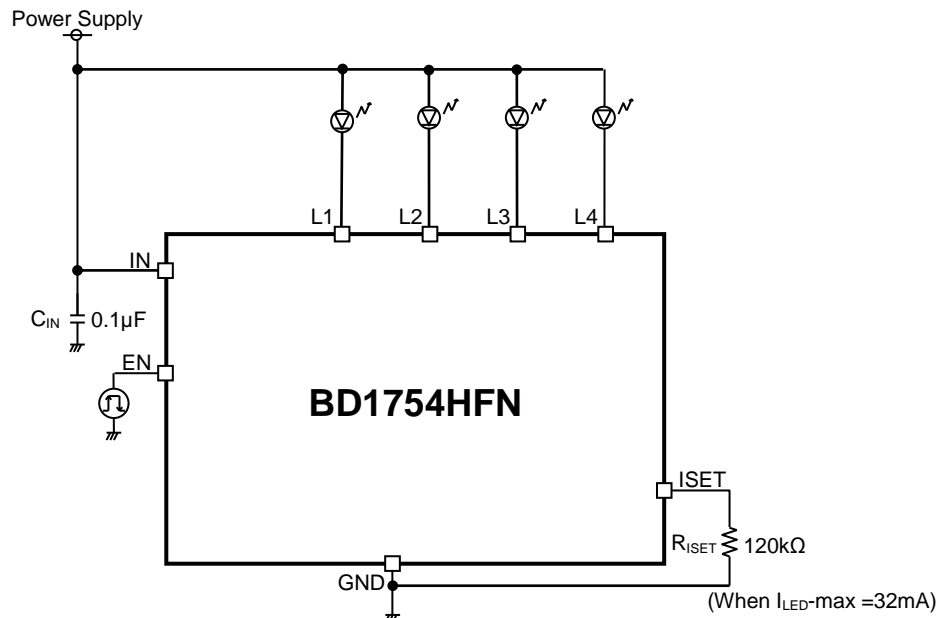

Absolute Maximum Ratings (Ta = 25°C)

Parameter	Symbol	Rating	Unit
Maximum Applied Voltage	V _{MAX}	7	V
Power Dissipation	Pd	0.63 (Note 1)	W
Operating Temperature Range	Topr	-30 to +85	°C
Storage Temperature Range	Tstg	-55 to +150	°C

(Note 1) When mounted on a glass epoxy board (70 mm x 70 mm x 1.6 mm). Derate by 5.04 mW/°C for Ta higher than 25 °C.

Caution: Operating the IC over the absolute maximum ratings may damage the IC. The damage can either be a short circuit between pins or an open circuit between pins. Therefore, it is important to consider circuit protection measures, such as adding a fuse, in case the IC is operated over the absolute maximum ratings.

Recommended Operating Conditions (Ta = -30°C to +85°C)

Parameter	Symbol	Rating			Unit	Conditions
		Min	Typ	Max		
Operating Power Supply Voltage	V _{IN}	2.7	3.6	5.5	V	
Driver Pin Voltage Range	V _{DRV}	0.2	-	V _{IN} -1.4	V	When Current driver power ON.

Electrical Characteristics (Unless otherwise specified, Ta = 25°C and V_{IN} = 3.6V)

Parameter	Symbol	Limit			Unit	Conditions
		Min	Typ	Max		
Quiescent Current	I _Q	-	0.1	1	μA	V _{EN} =0V
Circuit Current	I _{DD}	-	1.2	2.0	mA	Except LED current
[Current Driver]						
Maximum Current	I _{LED-MAX}	29.76	32.0	34.24	mA	R _{ISSET} = 120kΩ
LED Current Accuracy	I _{LED-diff}	-	-	7.0	%	When current 16.5 mA setting R _{ISSET} = 120kΩ
LED Current Matching	I _{LED-match}	-	0.5	3.0 (Note 1)	%	When current 16.5 mA setting R _{ISSET} = 120kΩ
[Logic Controller]						
Low Threshold Voltage	V _{IL}	-	-	0.4	V	
High Threshold Voltage	V _{IH}	1.4	-	-	V	
'H' Level Input Current	I _{IH}	-	0	2	μA	V _{EN} =V _{IN}
'L' Level Input Current	I _{IL}	-2	0	-	μA	V _{EN} =0V
EN 'H' Time	t _{HI}	0.05	-	100	μsec	
EN 'L' Time	t _{LO}	0.3	-	100	μsec	
EN OFF Time-Out	t _{OFF}	1	-	-	msec	
IN Supply -> EN Active Time	t _{VINON}	1	-	-	msec	
EN Stand-by -> VBAT OFF Time	t _{VINOFF}	0	-	-	msec	

(Note 1) The following formula is used for calculation:

$$I_{LED-match} = \{(I_{MAX} - I_{MIN}) / (I_{MAX} + I_{MIN})\} \times 100$$

I_{MAX} = The maximum current value from all channels

I_{MIN} = The minimum current value from all channels

Pin Description

No.	Pin Name	In/ Out	ESD Diode		Functions
			For Power	For GND	
1	EN	In	IN	GND	LED enable and Brightness control signal
2	GND	-	IN	-	Ground
3	ISET	Out	IN	GND	Bias current
4	IN	-	-	GND	Power supply voltage input
5	L1	Out	-	GND	Current sink for LED 1
6	L2	Out	-	GND	Current sink for LED 2
7	L3	Out	- </td <td>GND</td> <td>Current sink for LED 3</td>	GND	Current sink for LED 3
8	L4	Out	-	GND	Current sink for LED 4
-	Thermal PAD	-	-	-	Heat radiation PAD of back side Connect to GND

Block Diagram

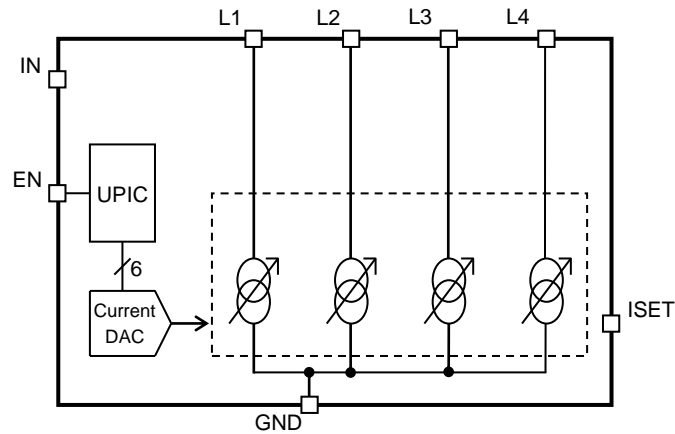

Typical Performance Curves

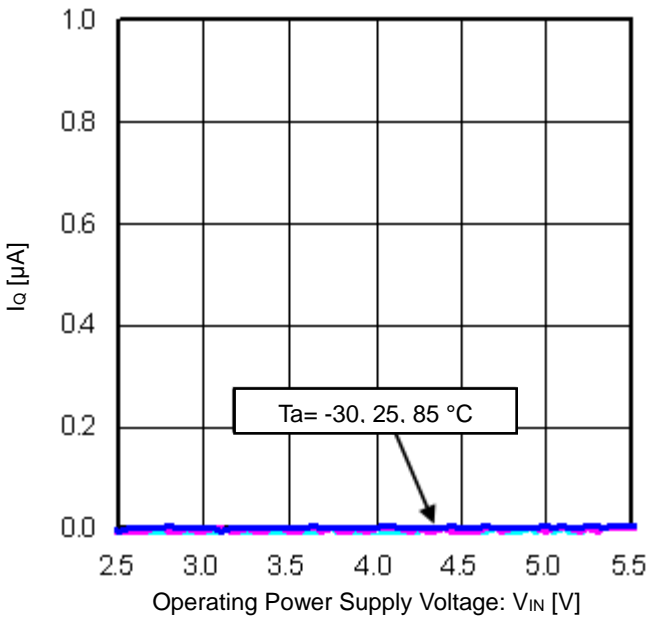

Figure 1. Circuit Current vs Operating Power Supply Voltage (Stand-By)

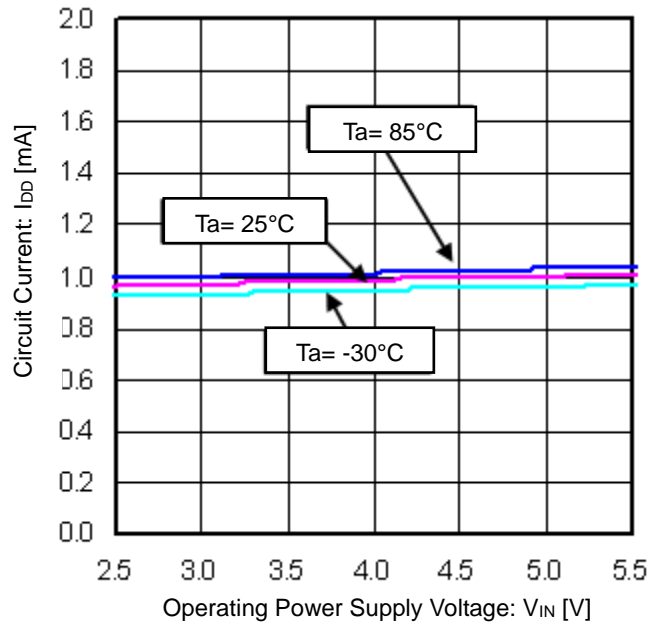

Figure 2. Circuit Current vs Operating Power Supply Voltage

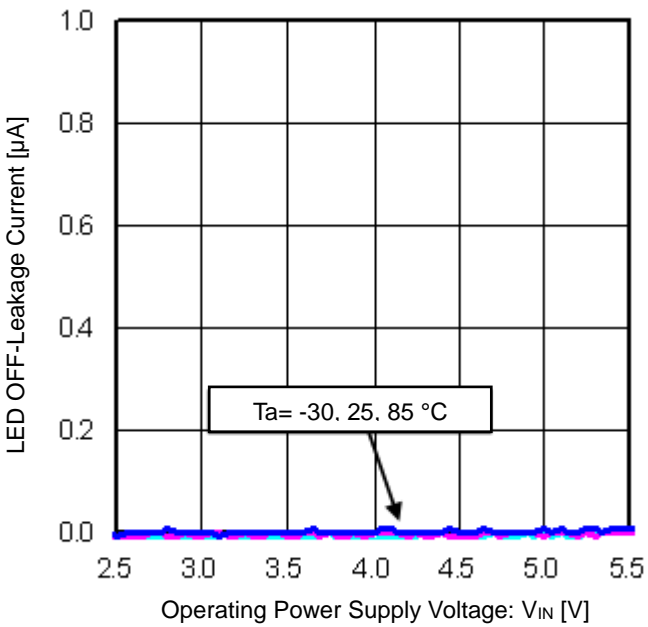

Figure 3. LED OFF-Leakage Current vs Operating Power Supply Voltage

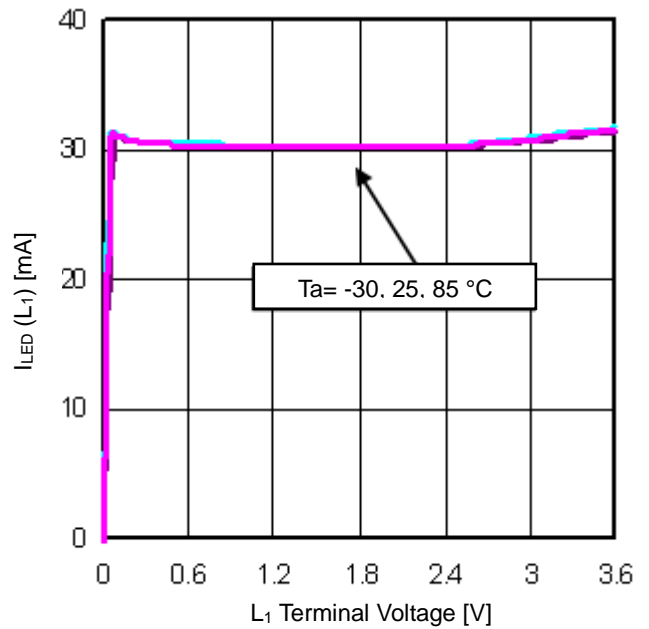

Figure 4. LED Output Current vs LED Pin Voltage (V_{IN} = 3.6 V, at 32 mA of LED Current)

Typical Performance Curves - continued

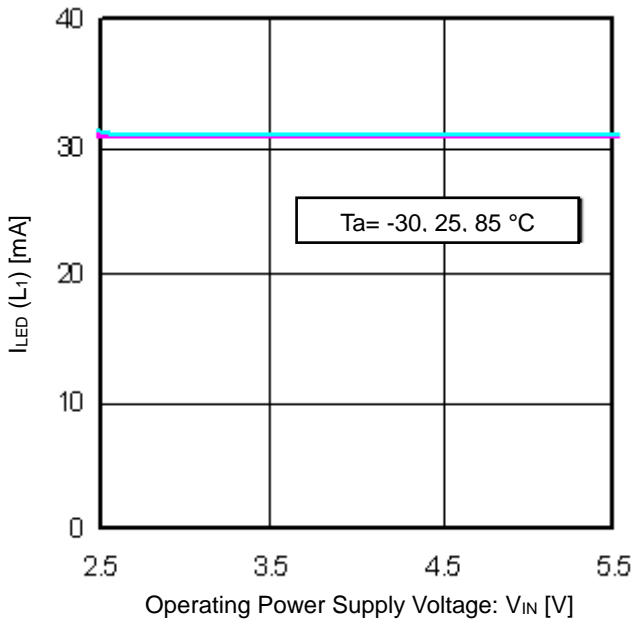

Figure 5. LED Output Current vs Operating Power Supply Voltage (V_{IN} = 3.6 V, at 32 mA of LED Current)

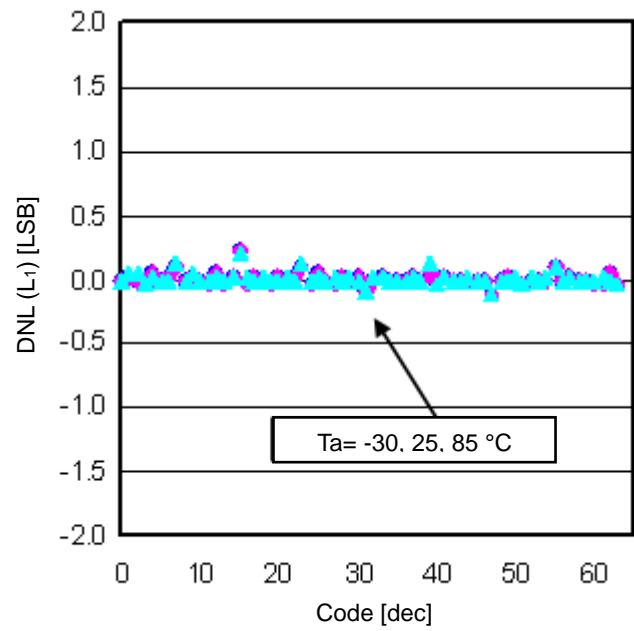

Figure 6. LED Current Characteristics (V_{IN} = 3.6 V, Differential Linearity Error)

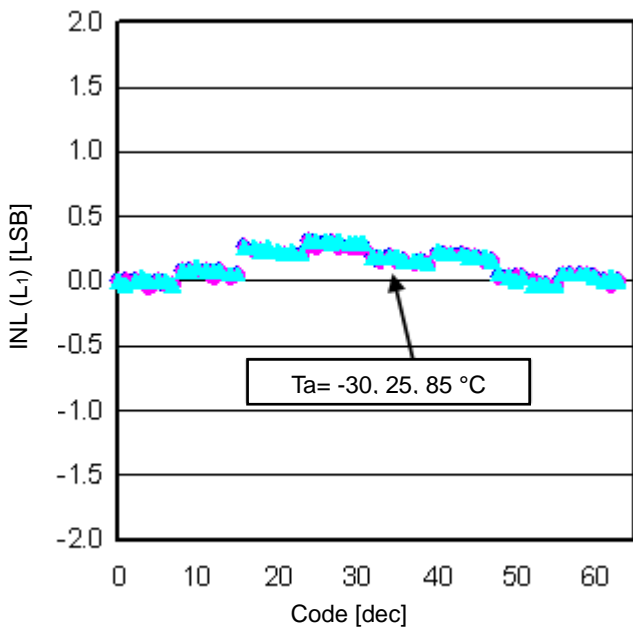

Figure 7. LED Current Characteristics (V_{IN} = 3.6 V, Integral Linearity Error)

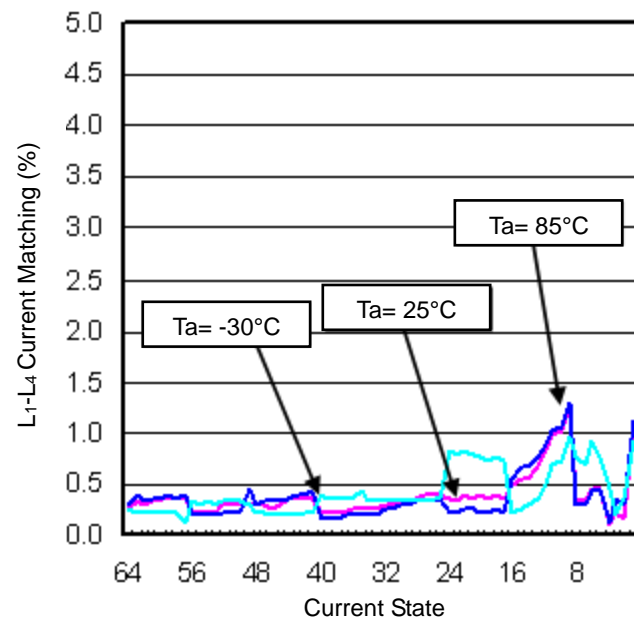

Figure 8. LED Current Relative Accuracy (V_{IN} = 3.6 V)

Typical Performance Curves - continued

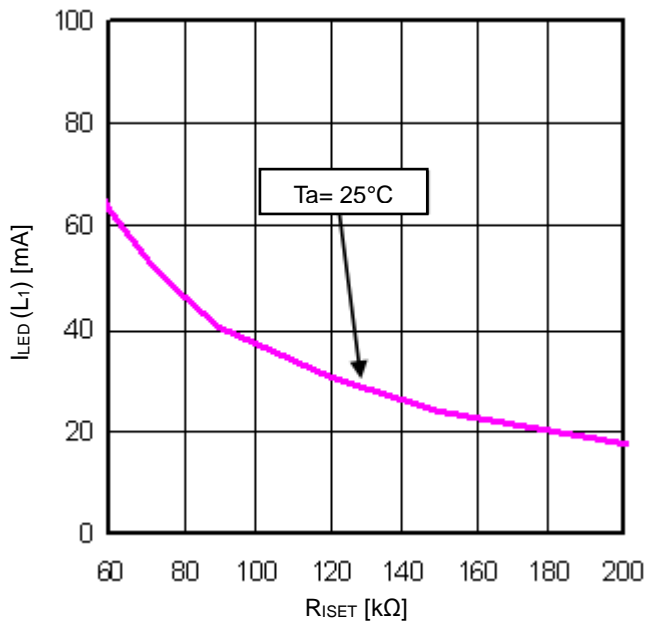

Figure 9. LED Current vs R_{ISET}
($V_{IN} = 3.6\text{ V}$, at the Maximum Current Setting)

Application Information

1. Description of Operations

(1) UPIC (= Uni-Port Interface Control) interface

BD1754HFN has a single-line digital control interface (UPIC) that can control the power ON/OFF and LED current value through the EN pin. The LED current decreases by one step depending on the number of rising edges. When the minimum output current is reached (64 rising edges), the next rising edge changes the output current to the maximum value at startup time. To maintain any output current, the EN pin must be kept at 'H' level. To power OFF, the EN pin must be kept at 'L' level for more than 1msec.

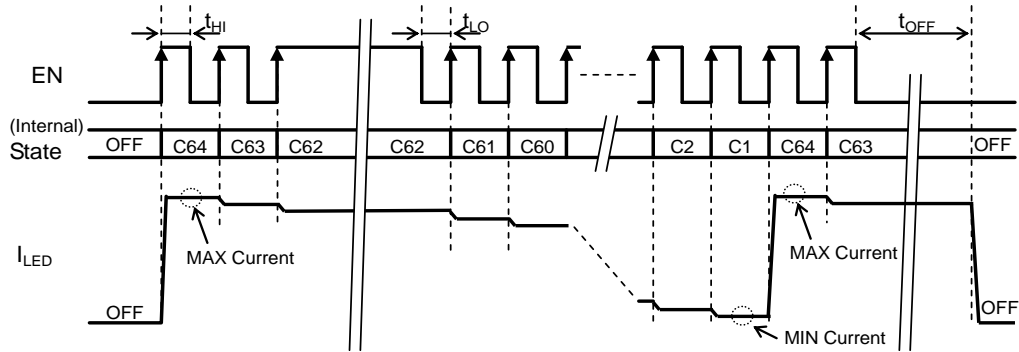

Figure 10. Brightness Control Method

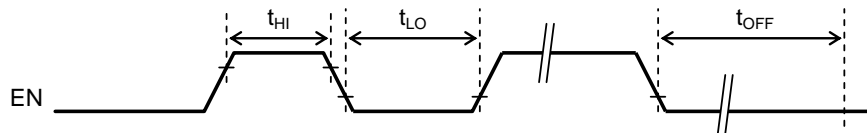

Figure 11. UPIC Interface

By the following sequence, UPIC can control the current driver for MAX current and OFF state only.

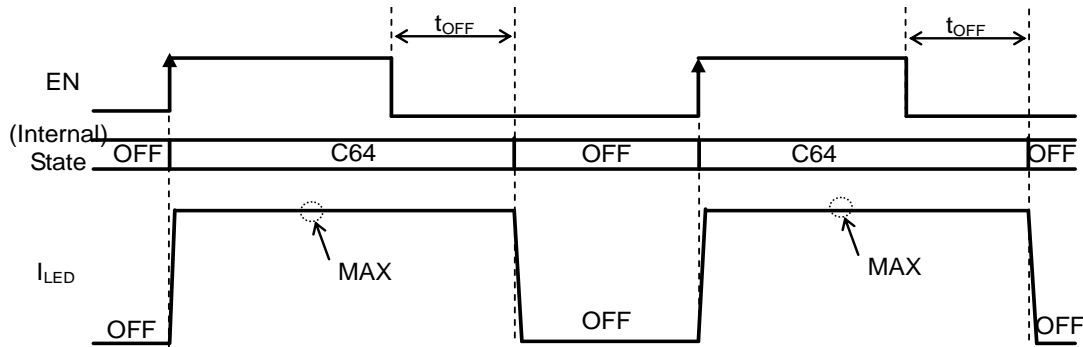

Figure 12. UPIC Interface Usage for MAX current or OFF Only

(2) Current Driver

The MAX Current is determined by the ISET resistance and the following formula.

$$I_{LED - \max} [mA] = 6.4 \times 600 [mV] / R_{ISET} [k\Omega]$$

The LED current state can be changed by the EN control signal. When the state is C n , the output current (I_{LED}) can be obtained from the following formula (where, n indicates a state number).

$$I_{LED} [mA] = I_{LED - \max} \times n / 64$$

The table below shows an example of the LED current settings, when ISET resistance is 120 [kΩ].

R_{ISET} : 120[kΩ]

State	Output Current [mA]	State	Output Current [mA]	State	Output Current [mA]	State	Output Current [mA]
C64	32.0	C48	24.0	C32	16.0	C16	8.0
C63	31.5	C47	23.5	C31	15.5	C15	7.5
C62	31.0	C46	23.0	C30	15.0	C14	7.0
C61	30.5	C45	22.5	C29	14.5	C13	6.5
C60	30.0	C44	22.0	C28	14.0	C12	6.0
C59	29.5	C43	21.5	C27	13.5	C11	5.5
C58	29.0	C42	21.0	C26	13.0	C10	5.0
C57	28.5	C41	20.5	C25	12.5	C9	4.5
C56	28.0	C40	20.0	C24	12.0	C8	4.0
C55	27.5	C39	19.5	C23	11.5	C7	3.5
C54	27.0	C38	19.0	C22	11.0	C6	3.0
C53	26.5	C37	18.5	C21	10.5	C5	2.5
C52	26.0	C36	18.0	C20	10.0	C4	2.0
C51	25.5	C35	17.5	C19	9.5	C3	1.5
C50	25.0	C34	17.0	C18	9.0	C2	1.0
C49	24.5	C33	16.5	C17	8.5	C1	0.5

When the state is C64 (the maximum value), the output current value can be changed on the ISET resistance value as below.

State : C64

ISET Resistance Value (kΩ)	Output Current per Channel (mA)	Total Output Current of the Four Channels (mA)
240	16.0	64.0
120	32.0	128.0
90	42.7	170.8
60	64.0	256.0

2. Application Circuit Examples

(1) Circuit example when the power supply is separated

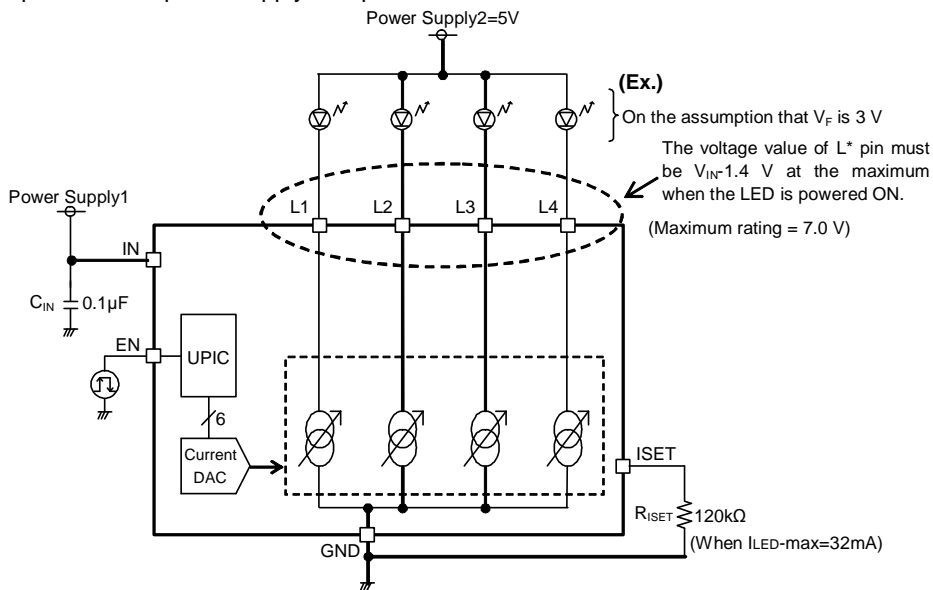

Figure 13. Circuit Example when the Power Supply is separated

This figure shows a circuit example when the power supply for IN and for LEDs is separated. Apply a voltage of V_F (threshold voltage value of a white LED) or higher to the LED. In this case, please note that when the LED is powered ON, the voltage value of L^* pin (each pin of L1 to L4) must be $V_{IN}-1.4$ V at the maximum. If a voltage of higher than $V_{IN}-1.4$ V is applied to L^* pin, a desired current value cannot be obtained. Also, please pay attention to the voltage application procedure at start-up. Be sure to power the current driver ON using the UPIC after applying power supply voltages to the IN and the LED-anode pins. If the current driver is powered ON prior to applying power supply voltages to the LED, a rush current occurs in the LED. Determine the resistance value with which the LED current value is maximized and then connect such resistor between the ISET and the GND pins. The power ON/OFF and the brightness of the LEDs are controlled through the EN pin in accordance with the UPIC format.

(2) Circuit example when using only two LEDs

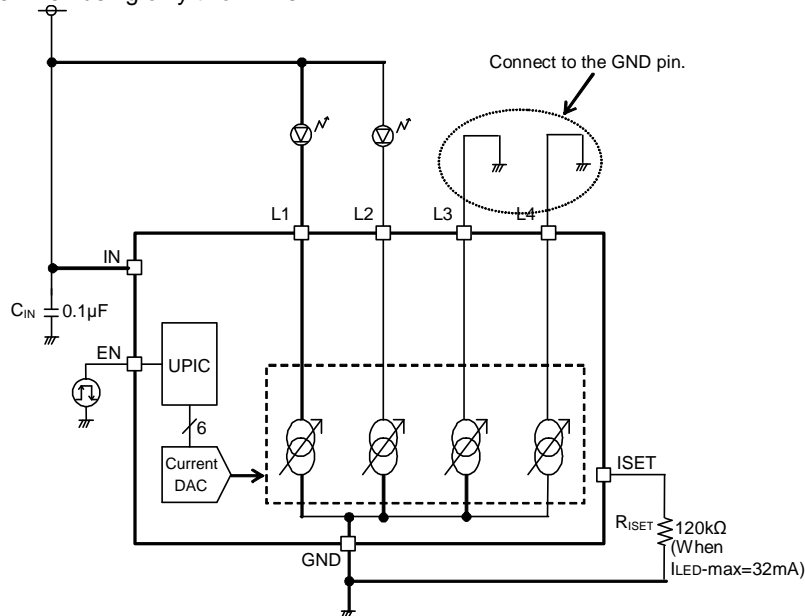

Figure 14. Circuit Example when using only Two LED's

This figure shows a circuit example when none of L3 and L4 LED's are used. Connect both of the unused L3 and L4 pins to the GND pin. Likewise, it is possible to make the L1 and/or the L2 pins unused, which allows the back lights to be used with the one or three LED(s) turned ON. In all cases, connect the unused L^* pin to the GND pin. Determine the resistance value with which the LED current value is maximized and then connect such resistor between the ISET and the GND pins. The power ON/OFF and the brightness of the LED's are controlled through the EN pin in accordance with the UPIC format.

(3) Circuit example when the EN pin is powered ON at all times

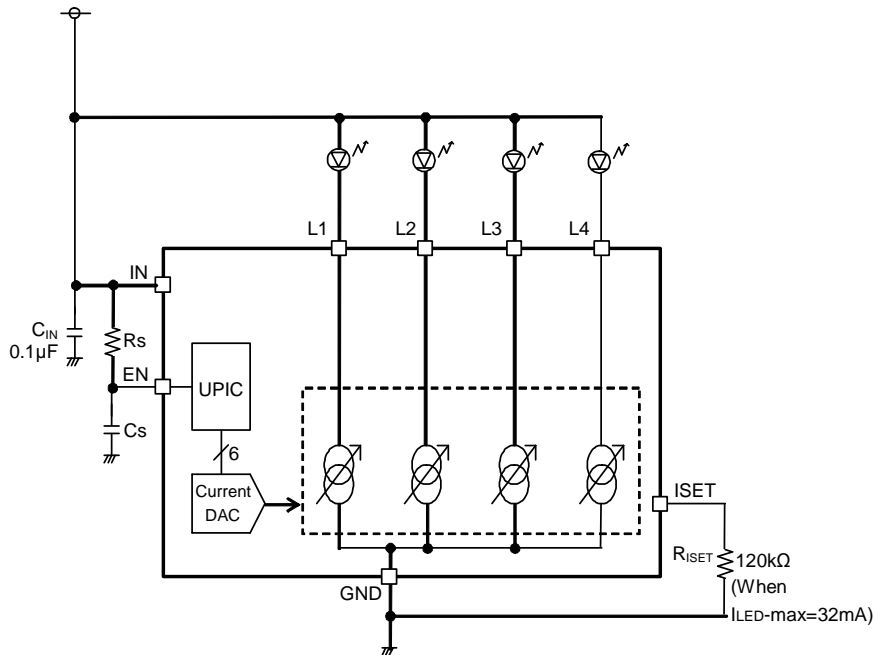

Figure 15. Circuit example when the EN Pin is Powered ON at all times

This figure shows a circuit example when the EN pin is powered ON at all times. To prevent a rush current from occurring in the driver, it is necessary to apply voltage to the IN pin and the LEDs prior to powering the current driver ON. Mount an RC filter between the IN and the EN pins to delay the EN pin rising against the power-supply voltage rising. Determine the resistance value with which the LED current value is maximized and then connect such resistor between the ISET and the GND pins.

(4) Circuit example when performing a PWM brightness control

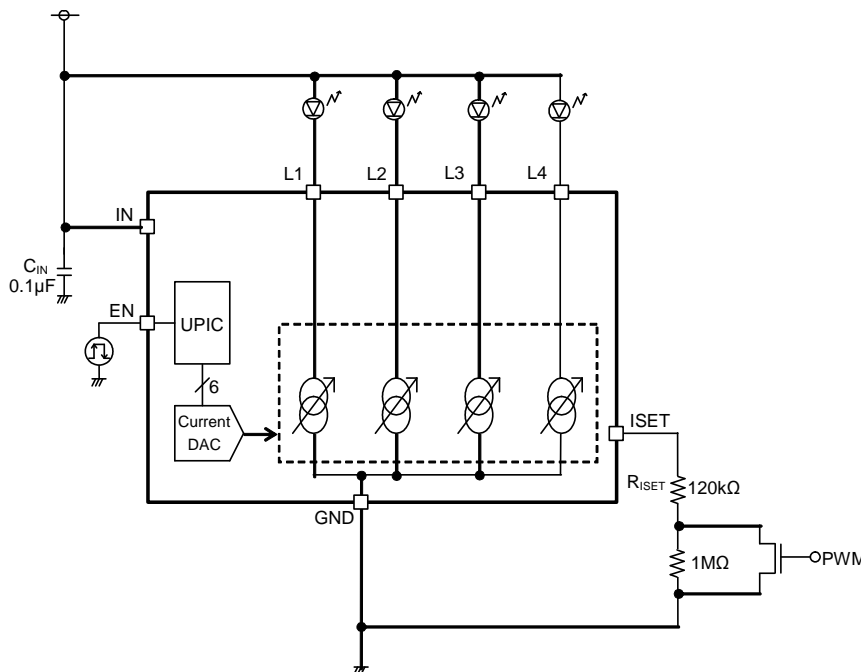

Figure 16. Circuit example when performing a PWM brightness control

This figure shows a circuit example when performing a PWM brightness control. Through switching the ISET resistance value by the PWM input signal, the LED current is outputted under a PWM mode. The EN signal is controlled by an applied voltage level. In the circuit example shown above, the LED current value is changed to 3.43 mA in 0 % of the PWM duty cycle, 17.72 mA in 50 % of that and 32 mA in 100 % of that.

(5) Circuit example when driving a large current with only one LED powered ON.

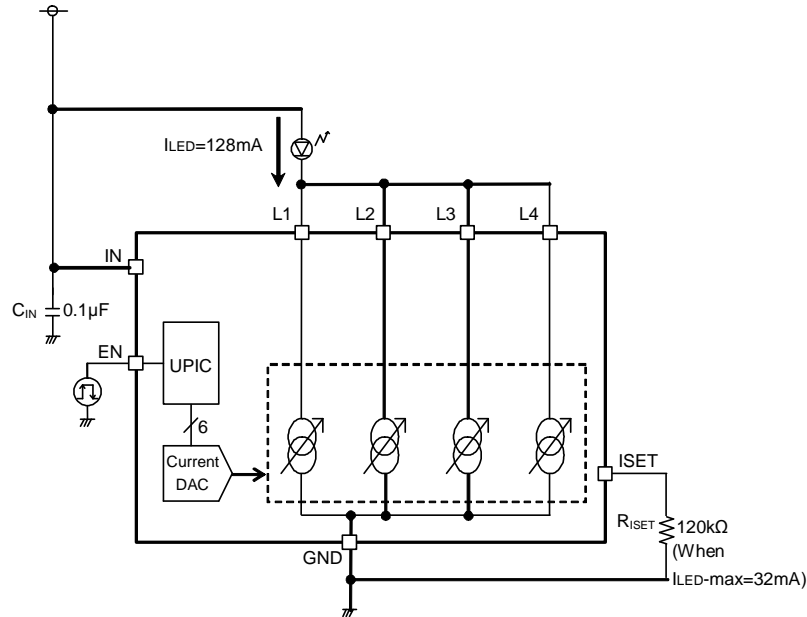

Figure 17. Circuit Example when Driving a Large Current with only one LED Powered ON.

This figure shows a circuit example when driving a large current through all of four channels with only one LED powered ON. By shorting out all the LED driver pins, in the example of using 120 kΩ R_{ISET}, a current up to 128 mA (32 mA x 4) can be driven. In this example, the brightness can be adjusted in 64 gradations with 2 mA step (0.5 mA step/channel x 4 channels). For higher current values, using 60 kΩ R_{ISET} allows a current up to 256 mA to be driven into one of the LEDs. The power ON/OFF and the brightness of the LEDs are controlled through the EN pin in accordance with the UPIC format.

(6) Circuit example when making the eight LEDs available by connecting the two BD1754HFN drivers

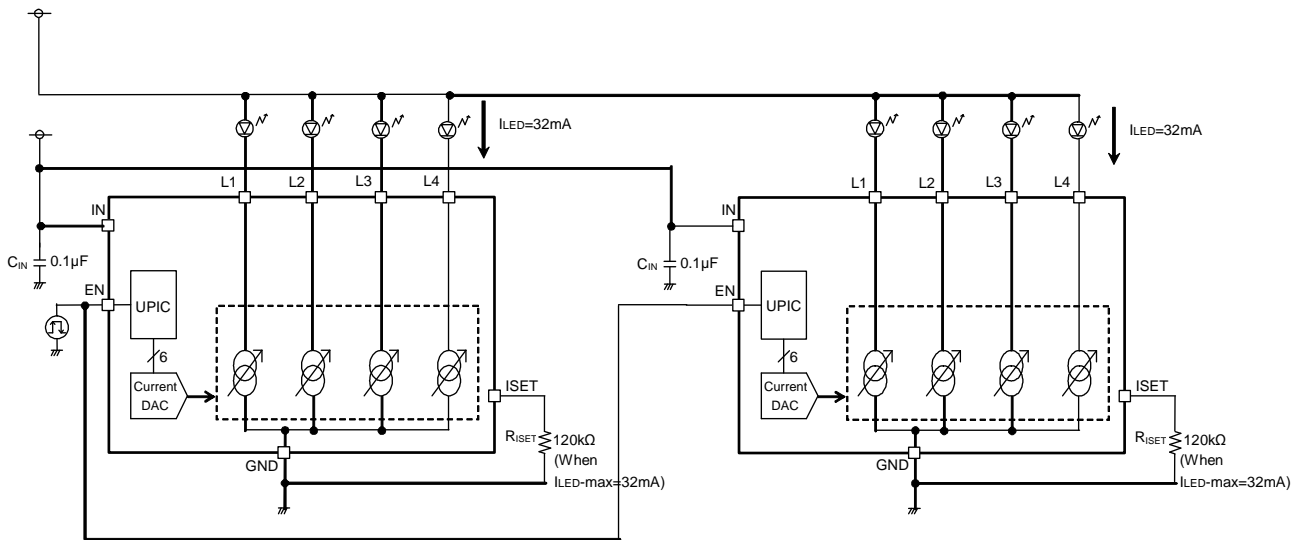

Figure 18. Circuit Example when Making the Eight LEDs Available by Connecting the Two BD1754HFN Drivers

This figure shows a circuit example when making eight LEDs available by connecting two BD1754HFN drivers. By connecting the control signals to the EN pins in parallel, the eight LED channels can be controlled concurrently. This parallel connection scheme can increase the number of the LED channels further as necessary (such as twelve, sixteen, or more). Determine the resistance value with which the LED current value is maximized and then connect such resistor between the ISET and the GND pins. The power ON/OFF and the brightness of the LEDs are controlled through the EN pin in accordance with the UPIC format.

(7) Circuit example when connecting the two LEDs to each of the channels in series

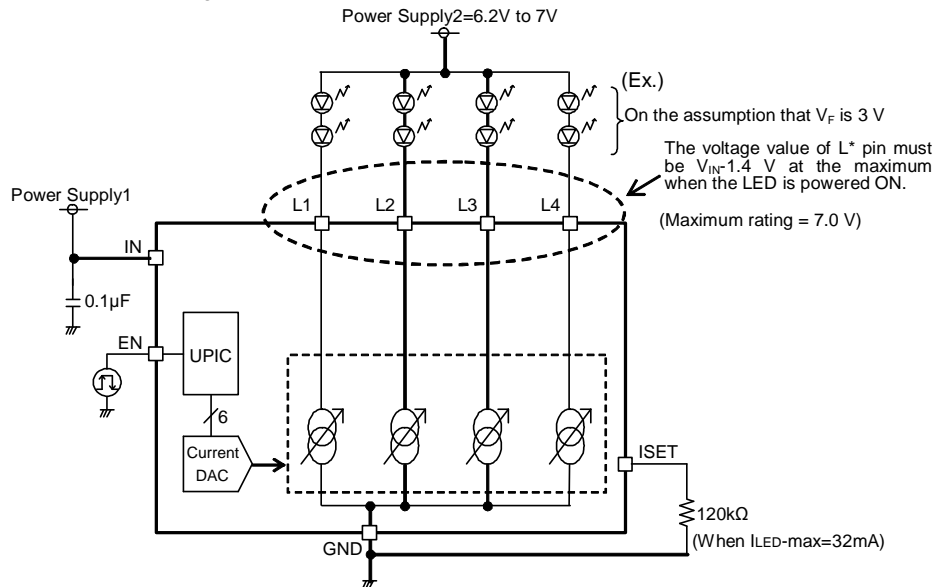

Figure 19. Circuit example when connecting the two LEDs to each of the channels in series

This figure shows a circuit example when making 8 (2 x 4) LEDs available by connecting two LEDs to each of the channels in series. In this example, when V_F is set to approx. 3 V in order to ensure the voltage to L1 through L4 pins, it is necessary to apply a voltage of 6.2 V (3 V x 2 LEDs in series + 0.2 V of the minimum voltage value of the driver pin) or higher to the LED anode pin as its power supply voltage. Pay attention that the voltage should not exceed the 7.0-V maximum rating of the L1 through L4 pins. Determine the resistance value with which the LED current value is maximized and then connect such resistor between the ISET and the GND pins. The power ON/OFF and the brightness of the LEDs are controlled through the EN pin in accordance with the UPIC format.

3. Selection of Components Externally Connected

<Capacitor>

Symbol	Recommended Value	Recommended Component	Manufacturer
C _{IN}	0.1µF	GRM188B31H104KA92B	MURATA

<Resistor>

Symbol	Recommended Value	Recommended Component	Manufacturer
R _{ISET}	120kΩ	MCR10PZHZF1203	ROHM

4. Recommended PCB Layout

Design PCB pattern to provide low impedance for the wiring to the power supply line. Also, provide a bypass capacitor if needed.

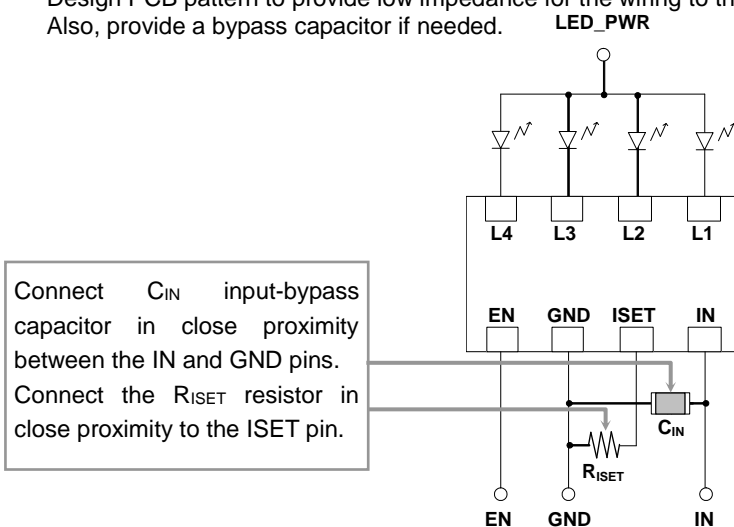

Figure 20. Layout Image of the Application Components (Top View)

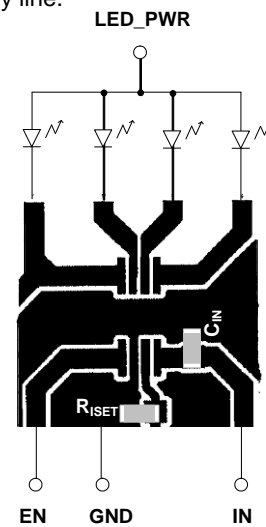

Figure 21. Surface (Top View)

<Heat radiation PAD of back side>

PAD is used for improving the efficiency of IC heat radiation. Solder PAD to GND pin. Moreover, connect ground plane (GND) of board using via as shown in the patterns of next page. The efficiency of heat radiation improves according to the area of ground plane (GND).

Operational Notes

1. Reverse Connection of Power Supply

Connecting the power supply in reverse polarity can damage the IC. Take precautions against reverse polarity when connecting the power supply, such as mounting an external diode between the power supply and the IC's power supply pins.

2. Power Supply Lines

Design the PCB layout pattern to provide low impedance supply lines. Separate the ground and supply lines of the digital and analog blocks to prevent noise in the ground and supply lines of the digital block from affecting the analog block. Furthermore, connect a capacitor to ground at all power supply pins. Consider the effect of temperature and aging on the capacitance value when using electrolytic capacitors.

3. Ground Voltage

Ensure that no pins are at a voltage below that of the ground pin at any time, even during transient condition.

4. Ground Wiring Pattern

When using both small-signal and large-current ground traces, the two ground traces should be routed separately but connected to a single ground at the reference point of the application board to avoid fluctuations in the small-signal ground caused by large currents. Also ensure that the ground traces of external components do not cause variations on the ground voltage. The ground lines must be as short and thick as possible to reduce line impedance.

5. Thermal Consideration

Should by any chance the power dissipation rating be exceeded the rise in temperature of the chip may result in deterioration of the properties of the chip. In case of exceeding this absolute maximum rating, increase the board size and copper area to prevent exceeding the Pd rating.

6. Recommended Operating Conditions

These conditions represent a range within which the expected characteristics of the IC can be approximately obtained. The electrical characteristics are guaranteed under the conditions of each parameter.

7. Inrush Current

When power is first supplied to the IC, it is possible that the internal logic may be unstable and inrush current may flow instantaneously due to the internal powering sequence and delays, especially if the IC has more than one power supply. Therefore, give special consideration to power coupling capacitance, power wiring, width of ground wiring, and routing of connections.

8. Operation Under Strong Electromagnetic Field

Operating the IC in the presence of a strong electromagnetic field may cause the IC to malfunction.

9. Testing on Application Boards

When testing the IC on an application board, connecting a capacitor directly to a low-impedance output pin may subject the IC to stress. Always discharge capacitors completely after each process or step. The IC's power supply should always be turned off completely before connecting or removing it from the test setup during the inspection process. To prevent damage from static discharge, ground the IC during assembly and use similar precautions during transport and storage.

10. Inter-pin Short and Mounting Errors

Ensure that the direction and position are correct when mounting the IC on the PCB. Incorrect mounting may result in damaging the IC. Avoid nearby pins being shorted to each other especially to ground, power supply and output pin. Inter-pin shorts could be due to many reasons such as metal particles, water droplets (in very humid environment) and unintentional solder bridge deposited in between pins during assembly to name a few.

Operational Notes – continued

11. Unused Input Pins

Input pins of an IC are often connected to the gate of a MOS transistor. The gate has extremely high impedance and extremely low capacitance. If left unconnected, the electric field from the outside can easily charge it. The small charge acquired in this way is enough to produce a significant effect on the conduction through the transistor and cause unexpected operation of the IC. So unless otherwise specified, unused input pins should be connected to the power supply or ground line.

12. Regarding the Input Pin of the IC

This monolithic IC contains P+ isolation and P substrate layers between adjacent elements in order to keep them isolated. P-N junctions are formed at the intersection of the P layers with the N layers of other elements, creating a parasitic diode or transistor. For example (refer to figure below):

When $GND > Pin A$ and $GND > Pin B$, the P-N junction operates as a parasitic diode.

When $GND > Pin B$, the P-N junction operates as a parasitic transistor.

Parasitic diodes inevitably occur in the structure of the IC. The operation of parasitic diodes can result in mutual interference among circuits, operational faults, or physical damage. Therefore, conditions that cause these diodes to operate, such as applying a voltage lower than the GND voltage to an input pin (and thus to the P substrate) should be avoided.

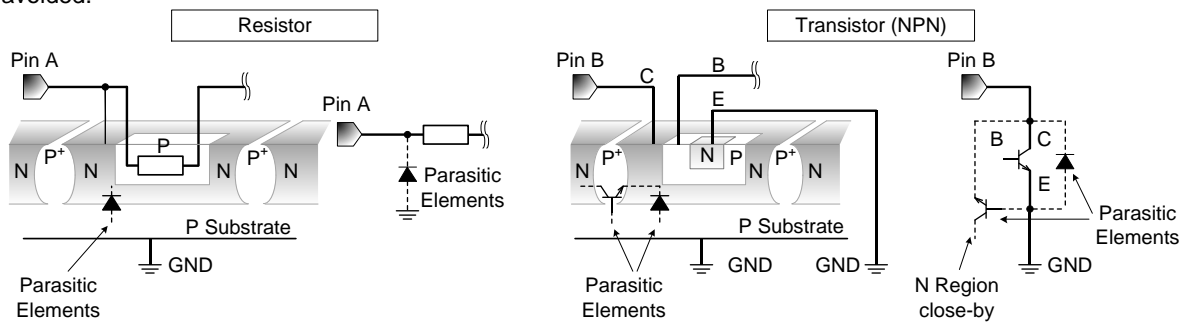
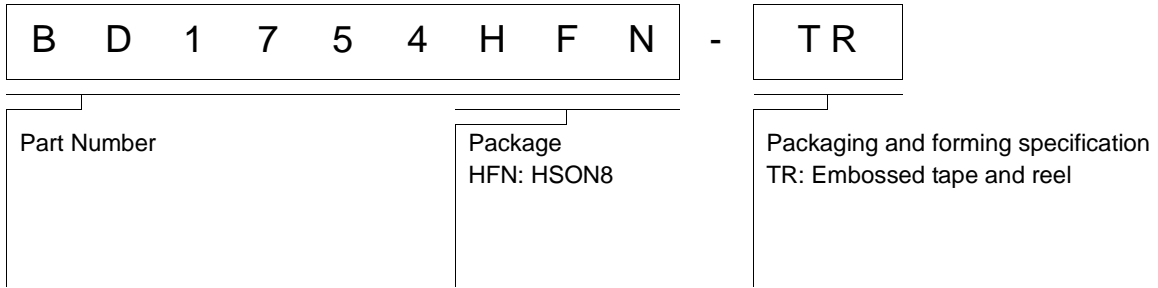
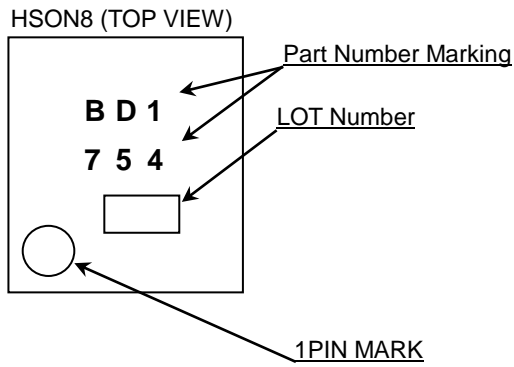

Figure 22. Example of monolithic IC structure

Ordering Information



Marking Diagram



Physical Dimension, Tape and Reel Information

Package Name	HSON8
--------------	-------

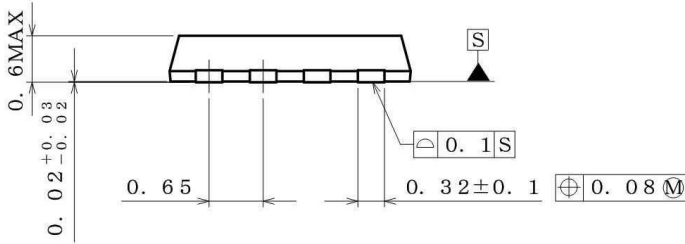
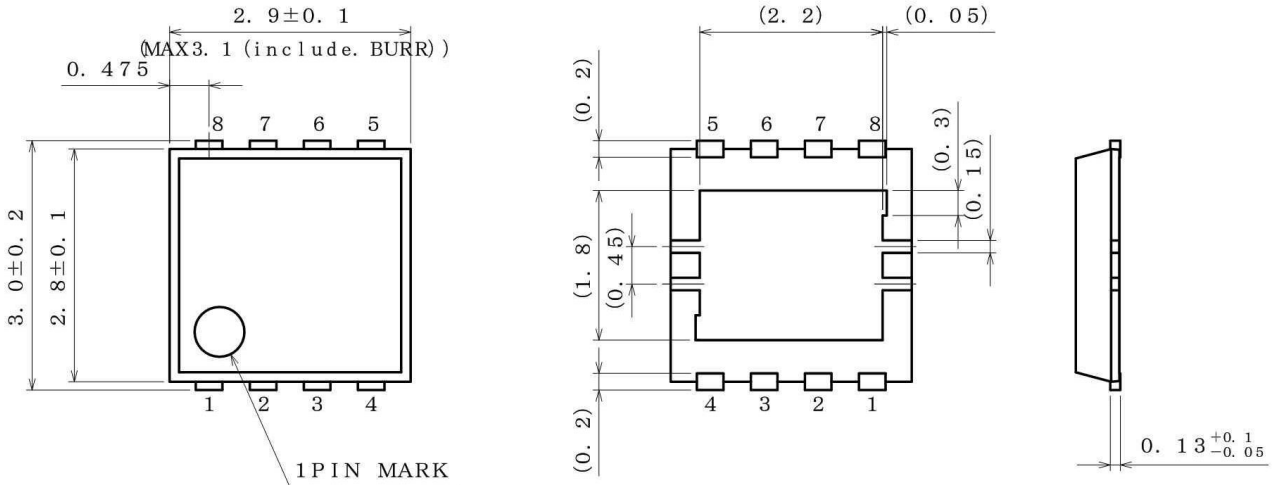

(UNIT : mm)
 PKG : HSON8
 Drawing No. EX163-5002

<Tape and Reel information>

Tape	Embossed carrier tape
Quantity	3000pcs
Direction of feed	TR (The direction is the 1pin of product is at the upper right when you hold reel on the left hand and you pull out the tape on the right hand)

*Order quantity needs to be multiple of the minimum quantity.

Revision History

Date	Revision	Changes
09.Nov.2012	001	New Release
10.Dec.2015	002	Applied the ROHM Standard Style and improved understandability.

Notice

Precaution on using ROHM Products

- Our Products are designed and manufactured for application in ordinary electronic equipments (such as AV equipment, OA equipment, telecommunication equipment, home electronic appliances, amusement equipment, etc.). If you intend to use our Products in devices requiring extremely high reliability (such as medical equipment ^(Note 1), transport equipment, traffic equipment, aircraft/spacecraft, nuclear power controllers, fuel controllers, car equipment including car accessories, safety devices, etc.) and whose malfunction or failure may cause loss of human life, bodily injury or serious damage to property ("Specific Applications"), please consult with the ROHM sales representative in advance. Unless otherwise agreed in writing by ROHM in advance, ROHM shall not be in any way responsible or liable for any damages, expenses or losses incurred by you or third parties arising from the use of any ROHM's Products for Specific Applications.

(Note1) Medical Equipment Classification of the Specific Applications

JAPAN	USA	EU	CHINA
CLASS III	CLASS III	CLASS II b	CLASS III
CLASS IV		CLASS III	

- ROHM designs and manufactures its Products subject to strict quality control system. However, semiconductor products can fail or malfunction at a certain rate. Please be sure to implement, at your own responsibilities, adequate safety measures including but not limited to fail-safe design against the physical injury, damage to any property, which a failure or malfunction of our Products may cause. The following are examples of safety measures:
 - Installation of protection circuits or other protective devices to improve system safety
 - Installation of redundant circuits to reduce the impact of single or multiple circuit failure
- Our Products are designed and manufactured for use under standard conditions and not under any special or extraordinary environments or conditions, as exemplified below. Accordingly, ROHM shall not be in any way responsible or liable for any damages, expenses or losses arising from the use of any ROHM's Products under any special or extraordinary environments or conditions. If you intend to use our Products under any special or extraordinary environments or conditions (as exemplified below), your independent verification and confirmation of product performance, reliability, etc. prior to use, must be necessary:
 - Use of our Products in any types of liquid, including water, oils, chemicals, and organic solvents
 - Use of our Products outdoors or in places where the Products are exposed to direct sunlight or dust
 - Use of our Products in places where the Products are exposed to sea wind or corrosive gases, including Cl₂, H₂S, NH₃, SO₂, and NO₂
 - Use of our Products in places where the Products are exposed to static electricity or electromagnetic waves
 - Use of our Products in proximity to heat-producing components, plastic cords, or other flammable items
 - Sealing or coating our Products with resin or other coating materials
 - Use of our Products without cleaning residue of flux (even if you use no-clean type fluxes, cleaning residue of flux is recommended); or Washing our Products by using water or water-soluble cleaning agents for cleaning residue after soldering
 - Use of the Products in places subject to dew condensation
- The Products are not subject to radiation-proof design.
- Please verify and confirm characteristics of the final or mounted products in using the Products.
- In particular, if a transient load (a large amount of load applied in a short period of time, such as pulse. is applied, confirmation of performance characteristics after on-board mounting is strongly recommended. Avoid applying power exceeding normal rated power; exceeding the power rating under steady-state loading condition may negatively affect product performance and reliability.
- De-rate Power Dissipation depending on ambient temperature. When used in sealed area, confirm that it is the use in the range that does not exceed the maximum junction temperature.
- Confirm that operation temperature is within the specified range described in the product specification.
- ROHM shall not be in any way responsible or liable for failure induced under deviant condition from what is defined in this document.

Precaution for Mounting / Circuit board design

- When a highly active halogenous (chlorine, bromine, etc.) flux is used, the residue of flux may negatively affect product performance and reliability.
- In principle, the reflow soldering method must be used on a surface-mount products, the flow soldering method must be used on a through hole mount products. If the flow soldering method is preferred on a surface-mount products, please consult with the ROHM representative in advance.

For details, please refer to ROHM Mounting specification

Precautions Regarding Application Examples and External Circuits

1. If change is made to the constant of an external circuit, please allow a sufficient margin considering variations of the characteristics of the Products and external components, including transient characteristics, as well as static characteristics.
2. You agree that application notes, reference designs, and associated data and information contained in this document are presented only as guidance for Products use. Therefore, in case you use such information, you are solely responsible for it and you must exercise your own independent verification and judgment in the use of such information contained in this document. ROHM shall not be in any way responsible or liable for any damages, expenses or losses incurred by you or third parties arising from the use of such information.

Precaution for Electrostatic

This Product is electrostatic sensitive product, which may be damaged due to electrostatic discharge. Please take proper caution in your manufacturing process and storage so that voltage exceeding the Products maximum rating will not be applied to Products. Please take special care under dry condition (e.g. Grounding of human body / equipment / solder iron, isolation from charged objects, setting of Ionizer, friction prevention and temperature / humidity control).

Precaution for Storage / Transportation

1. Product performance and soldered connections may deteriorate if the Products are stored in the places where:
 - [a] the Products are exposed to sea winds or corrosive gases, including Cl₂, H₂S, NH₃, SO₂, and NO₂
 - [b] the temperature or humidity exceeds those recommended by ROHM
 - [c] the Products are exposed to direct sunshine or condensation
 - [d] the Products are exposed to high Electrostatic
2. Even under ROHM recommended storage condition, solderability of products out of recommended storage time period may be degraded. It is strongly recommended to confirm solderability before using Products of which storage time is exceeding the recommended storage time period.
3. Store / transport cartons in the correct direction, which is indicated on a carton with a symbol. Otherwise bent leads may occur due to excessive stress applied when dropping of a carton.
4. Use Products within the specified time after opening a humidity barrier bag. Baking is required before using Products of which storage time is exceeding the recommended storage time period.

Precaution for Product Label

QR code printed on ROHM Products label is for ROHM's internal use only.

Precaution for Disposition

When disposing Products please dispose them properly using an authorized industry waste company.

Precaution for Foreign Exchange and Foreign Trade act

Since concerned goods might be fallen under listed items of export control prescribed by Foreign exchange and Foreign trade act, please consult with ROHM in case of export.

Precaution Regarding Intellectual Property Rights

1. All information and data including but not limited to application example contained in this document is for reference only. ROHM does not warrant that foregoing information or data will not infringe any intellectual property rights or any other rights of any third party regarding such information or data.
2. ROHM shall not have any obligations where the claims, actions or demands arising from the combination of the Products with other articles such as components, circuits, systems or external equipment (including software).
3. No license, expressly or implied, is granted hereby under any intellectual property rights or other rights of ROHM or any third parties with respect to the Products or the information contained in this document. Provided, however, that ROHM will not assert its intellectual property rights or other rights against you or your customers to the extent necessary to manufacture or sell products containing the Products, subject to the terms and conditions herein.

Other Precaution

1. This document may not be reprinted or reproduced, in whole or in part, without prior written consent of ROHM.
2. The Products may not be disassembled, converted, modified, reproduced or otherwise changed without prior written consent of ROHM.
3. In no event shall you use in any way whatsoever the Products and the related technical information contained in the Products or this document for any military purposes, including but not limited to, the development of mass-destruction weapons.
4. The proper names of companies or products described in this document are trademarks or registered trademarks of ROHM, its affiliated companies or third parties.

General Precaution

1. Before you use our Products, you are requested to carefully read this document and fully understand its contents. ROHM shall not be in any way responsible or liable for failure, malfunction or accident arising from the use of any ROHM's Products against warning, caution or note contained in this document.
2. All information contained in this document is current as of the issuing date and subject to change without any prior notice. Before purchasing or using ROHM's Products, please confirm the latest information with a ROHM sales representative.
3. The information contained in this document is provided on an "as is" basis and ROHM does not warrant that all information contained in this document is accurate and/or error-free. ROHM shall not be in any way responsible or liable for any damages, expenses or losses incurred by you or third parties resulting from inaccuracy or errors of or concerning such information.