

ACPL-M21L, ACPL-021L, ACPL-024L, ACPL-W21L, ACPL-K24L

Low Power, 5-MBd Digital CMOS Optocoupler

Description

The Broadcom[®] ACPL-M21L (single-channel SO-5 package), ACPL-021L (single-channel SO-8 package), ACPL-024L (dual-channel SO-8 package), ACPL-W21L (single-channel stretched SO-6 package), and ACPL-K24L (dual-channel stretched SO-8 package) are optically coupled logic gates. The detector IC has CMOS output stage and optical receiver input stage with built-in Schmitt trigger to provide logic-compatible waveforms, eliminating the requirement for additional waveshaping.

An internal shield on the ACPL-M21L/021L/024L/W21L/K24L guarantees common mode transient immunity of 25 kV/μs at a common-mode voltage of 1000V. The ACPL-x2xL optocouplers' series operates from a 2.7V to 5.5V supply with guaranteed AC and DC performance from an extended temperature range of -40°C to +105°C.

CAUTION! Take normal static precautions in handling and assembly of this component to prevent damage and/or degradation that might be induced by electrostatic discharge (ESD). The components featured in this data sheet are not to be used in military or aerospace applications or environments.

Features

- CMOS output
- Wide supply voltage: 2.7V to 5.5V
- Low power supply current I_{DD} : 1.1 mA/channel max.
- Low forward current I_F : 1.6 mA min.
- Speed: 5 MBd typ.
- Pulse width distortion (PWD): 200 ns max.
- Propagation delay skew (tpsk): 220 ns max.
- Propagation delay (tp): 250 ns max.
- Common mode rejection: 25 kV/μs min. at $V_{CM} = 1000V$
- Hysteresis: 0.2 mA typ.
- Temperature range: -40°C to +105°C
- Safety and regulatory approvals
 - UL 1577 recognized: 3750 V_{RMS} for 1 minute for ACPL-M21L/021L/024L and 5000 V_{RMS} for 1 minute for ACPL-W21L/K24L
 - CSA Approval
 - IEC/EN 60747-5-5, Approval for Reinforced Insulation

Applications

- Low isolation of high speed logic systems
- Computer peripheral interface
- Microprocessor system interface
- Ground loop elimination
- Pulse transformer replacement
- High-speed line receiver
- Power control systems

Figure 1: Functional Diagram

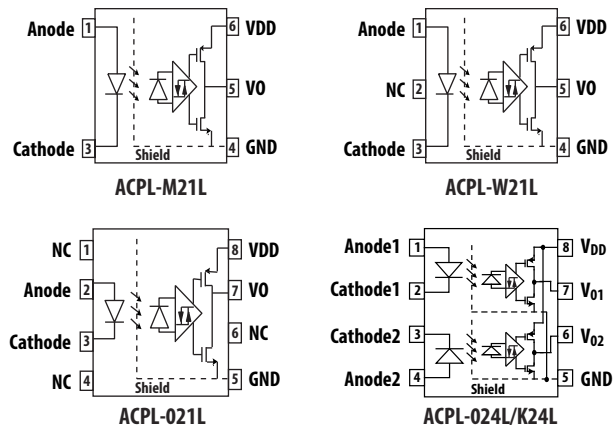

Table 1: Truth Table

LED	VO
ON	HIGH
OFF	LOW

NOTE: A 0.1- μ F bypass capacitor must be connected between pins Vdd and GND.

Ordering Information

ACPL-M21L, ACPL-024L, and ACPL-021L are UL Recognized with 3750 V_{RMS} for 1 minute per UL1577.

ACPL-W21L and ACPL-K24L are UL Recognized with 5000 V_{RMS} for 1 minute per UL1577.

Table 2: Ordering Information

Part Number	Option	Package	Surface Mount	Tape and Reel	UL1577 5000 V _{RMS} /1 Minute Rating	IEC/EN 60747-5-5	Quantity
	RoHS Compliant						
ACPL-M21L	-000E	SO-5	X				100 per tube
	-060E		X			X	100 per tube
	-500E		X	X			1500 per reel
	-560E		X	X		X	1500 per reel
ACPL-024L	-000E	SO-8	X				100 per tube
	-060E		X			X	100 per tube
	-500E		X	X			1500 per reel
	-560E		X	X		X	1500 per reel
ACPL-021L	-000E	SO-8	X				100 per tube
	-060E		X			X	100 per tube
	-500E		X	X			1500 per reel
	-560E		X	X		X	1500 per reel
ACPL-W21L	-000E	Stretched SO6	X		X		100 per tube
	-060E		X		X	X	100 per tube
	-500E		X	X	X		1000 per reel
	-560E		X	X	X	X	1000 per reel
ACPL-K24L	-000E	Stretched SO8	X		X		80 per tube
	-060E		X		X	X	80 per tube
	-500E		X	X	X		1000 per reel
	-560E		X	X	X	X	1000 per reel

To order, choose a part number from the part number column and combine with the desired option from the option column to form an order entry.

Example 1:

ACPL-M21L-500E to order product of SO-5 package in Tape and Reel packaging with RoHS compliant.

Option data sheets are available. Contact your Broadcom sales representative or authorized distributor for information.

Package Outline Drawings

Figure 2: ACPL-M21L SO-5 Package

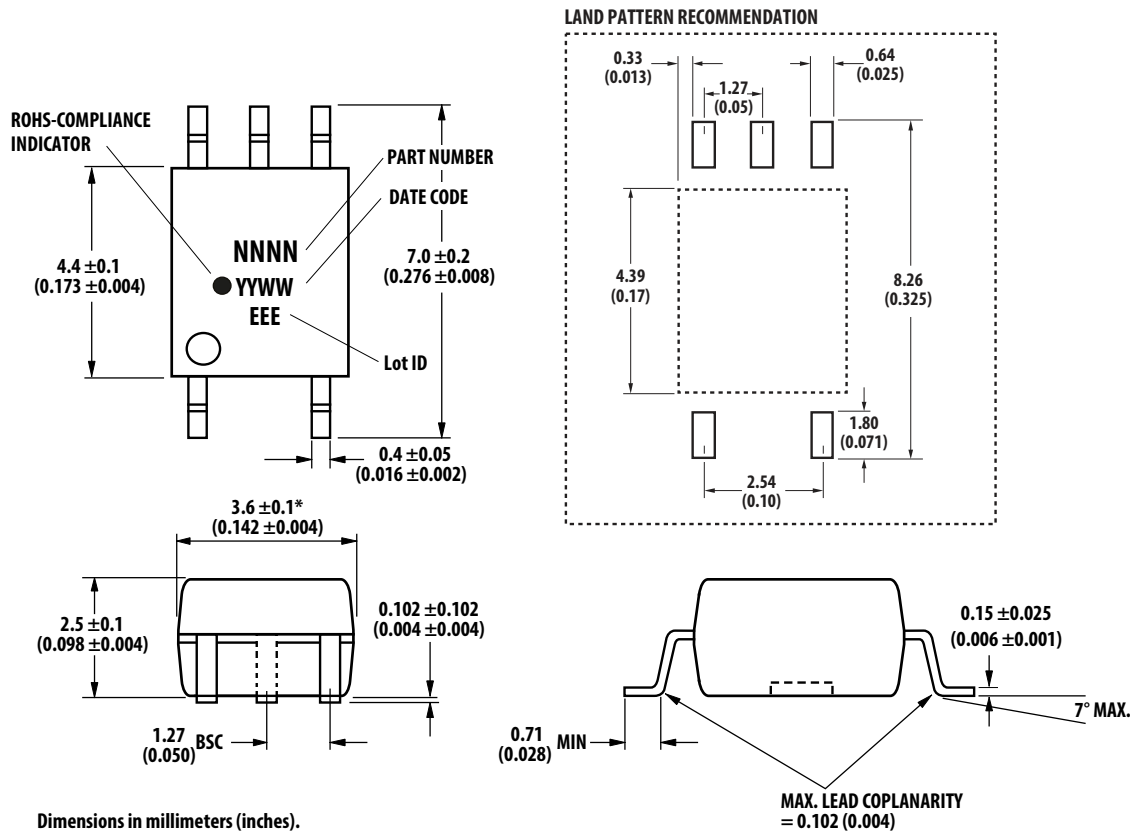

Dimensions in millimeters (inches).
 Note: Floating Lead Protrusion is 0.15 mm (6 mils) max.

* Maximum Mold flash on each side is 0.15 mm (0.006).

Figure 3: ACPL-024L/021L SO-8 Package

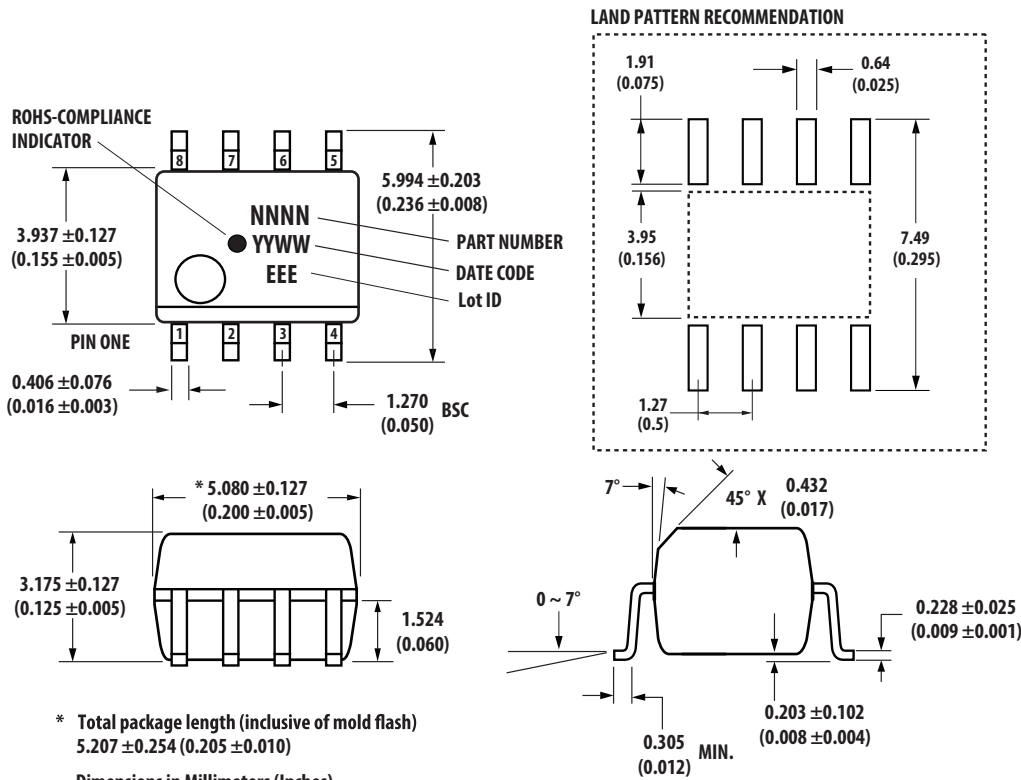

* Total package length (inclusive of mold flash)
 5.207 ± 0.254 (0.205 ± 0.010)

Dimensions in Millimeters (Inches).

Note: Floating lead protrusion is 0.15 mm (6 mils) max.
 Lead coplanarity = 0.10 mm (0.004 inches) max.

Option number 500 not marked.

Figure 4: ACPL-W21L Stretched SO-6 Package

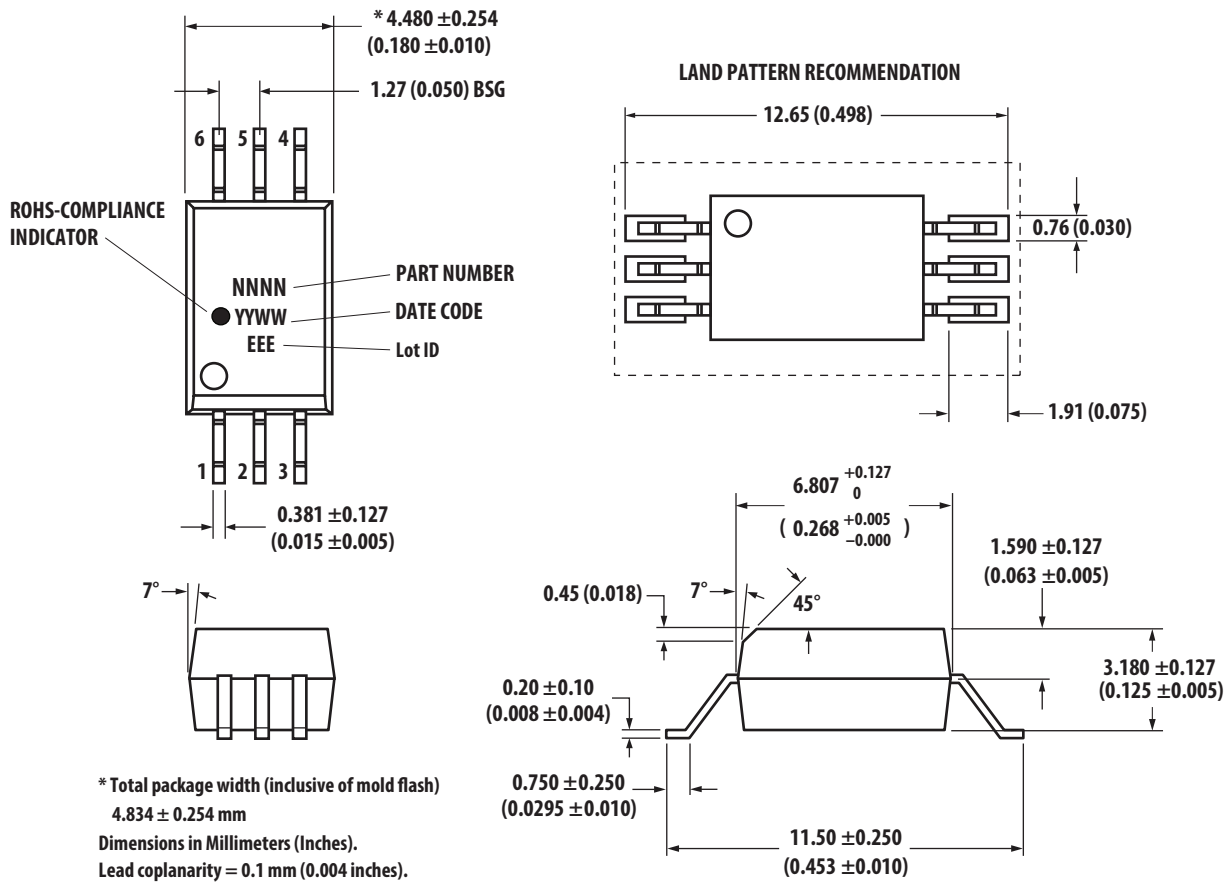
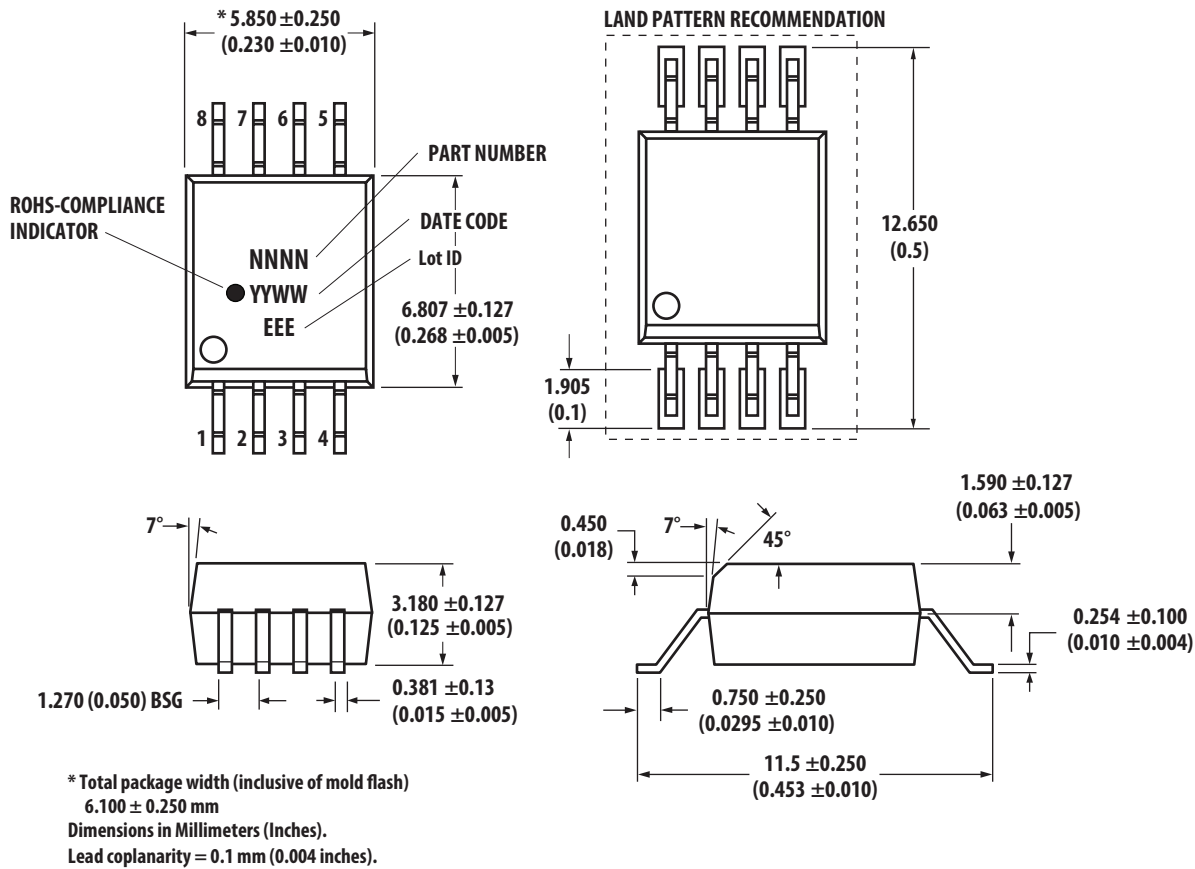

Figure 5: ACPL-K24L Stretched SO-8 Package Width



Solder Reflow Profile

Recommended reflow condition as per JEDEC Standard, J-STD-020 (latest revision). Non-halide flux should be used.

Regulatory Information

The ACPL-M21L/024L/021L/W21L/K24L is approved by the following organizations.

UL	Approval under UL 1577, component recognition program up to $V_{ISO} = 3750 V_{RMS}$ for ACPL-M21L/024L/021L and $V_{ISO} = 5000 V_{RMS}$ for ACPL-W21L/K24L.
CSA	Approval under CSA Component Acceptance Notice #5.
IEC/EN 60747-5-5	(Option 060 and 560 only).

Table 3: Insulation and Safety Related Specifications

Parameter	Symbol	ACPL-M21L	ACPL-024L ACPL-021L	ACPL-W21 ACPL-K24L	Units	Conditions
Minimum External Air Gap (Clearance)	L(101)	5	4.9	8	mm	Measured from input terminals to output terminals, shortest distance through air.
Minimum External Tracking (Creepage)	L(102)	5	4.8	8	mm	Measured from input terminals to output terminals, shortest distance path along body.
Minimum Internal Plastic Gap (Internal Clearance)		0.08	0.08	0.08	mm	Through insulation distance conductor to conductor, usually the straight line distance thickness between the emitter and detector.
Tracking Resistance (Comparative Tracking Index)	CTI	175	175	175	V	DIN IEC 112/VDE 0303 Part 1
Isolation Group		IIIa	IIIa	IIIa		Material Group (DIN VDE 0110, 1/89, Table 1)

Table 4: IEC/EN60747-5-5 Insulation Characteristics^a (Option 060 and 560 Only)

Description	Symbol	Characteristic		Units
		ACPL-M21L/ 024L/021L	ACPL-W21L/ K24L	
Installation classification per DIN VDE 0110/39, Table 1 for rated mains voltage ≤ 150 V _{rms} for rated mains voltage ≤ 300 V _{rms} for rated mains voltage ≤ 600 V _{rms} for rated mains voltage ≤ 1000 V _{rms}		I – IV I – III I – II	I – IV I – IV I – III I – III	
Climatic Classification		55/105/21	55/105/21	
Pollution Degree (DIN VDE 0110/39)		2	2	
Maximum Working Insulation Voltage	V _{IORM}	567	1140	V _{peak}
Input to Output Test Voltage, Method b ^a V _{IORM} × 1.875 = V _{PR} , 100% Production Test with t _m = 1s, Partial discharge < 5 pC	V _{PR}	1063	2137	V _{peak}
Input to Output Test Voltage, Method a ^a V _{IORM} × 1.6 = V _{PR} , Type and Sample Test, t _m = 10s, Partial discharge < 5 pC	V _{PR}	896	1824	V _{peak}
Highest Allowable Overvoltage (Transient Overvoltage t _{ini} = 60s)	V _{IOTM}	6000	8000	V _{peak}
Safety-limiting values – maximum values allowed in the event of a failure. Case Temperature	T _S	150	175	°C
Input Current ^b	I _{S, INPUT}	150	230	mA
Output Power ^b	P _{S, OUTPUT}	600	600	mW
Insulation Resistance at T _S , V _{IO} = 500V	R _S	>10 ⁹	>10 ⁹	Ω

- a. Refer to the optocoupler section of the Isolation and Control Components Designer’s Catalog, under Product Safety Regulations section, (IEC/EN 60747-5-5) for a detailed description of Method a and Method b partial discharge test profiles.
- b. Refer to the following figure for dependence of P_S and I_S on ambient temperature.

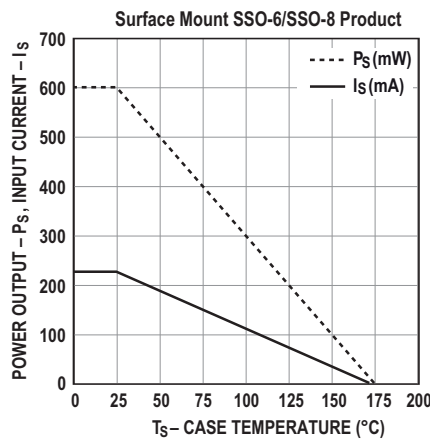
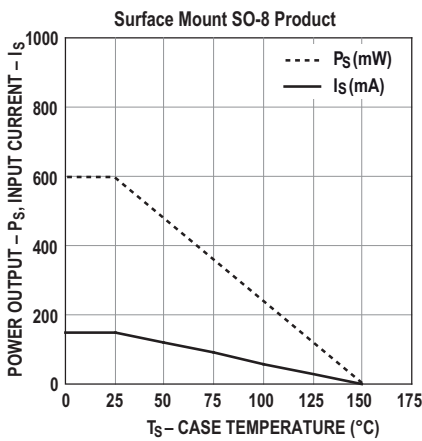

NOTE: These optocouplers are suitable for *safe electrical isolation* only within the safety limit data. Maintenance of the safety limit data shall be ensured by means of protective circuits.

Table 5: Absolute Maximum Ratings

Parameter	Symbol	Min.	Max.	Units	Condition
Storage Temperature	T_S	-55	125	°C	
Operating Temperature	T_A	-40	105	°C	
Reverse Input Voltage	V_R	—	5	V	
Supply Voltage	V_{DD}	—	6.5	V	
Average Forward Input Current	I_F	—	8	mA	
Peak Forward Input Current	$I_{F(TRAN)}$	—	1	A	$\leq 1\text{-}\mu\text{s}$ pulse width, <300 pulses per second
Output Current	I_O	—	10	mA	At max V_{DD}
Output Voltage	V_O	-0.5	$V_{DD} + 0.5$	V	
Lead Solder Temperature	T_{LS}	—	260°C for 10s., 1.6 mm below seating plane		
Solder Reflow Temperature Profile	See Package Outline Drawings				

Table 6: Recommended Operating Conditions

Parameter	Symbol	Min.	Max.	Units
Operating Temperature	T_A	-40	105	°C
Input Current, Low Level	I_{FL}	0	250	μA
Input Current, High Level	I_{FH}	1.6 ^a	6	mA
Power Supply Voltage	V_{DD}	2.7	5.5	V
Forward Input Voltage	$V_{F(OFF)}$	—	0.8	V

a. The initial switching threshold is 1.6 mA or less. It is recommended that 2.2 mA be used to permit at least a 20% LED degradation guardband.

Electrical Specifications (DC)

Over recommended temperature ($T_A = -40^{\circ}\text{C}$ to $+105^{\circ}\text{C}$) and supply voltage ($2.7\text{V} \leq V_{DD} \leq 5.5\text{V}$). All typical specifications are at $V_{DD} = 2.7\text{V}$, $T_A = 25^{\circ}\text{C}$, unless otherwise specified.

Table 7: Electrical Specifications (DC)

Parameter	Symbol	Channel	Min.	Typ.	Max.	Units	Test Conditions
Input Forward Voltage	V_F		—	1.5	2.0	V	$I_F = 2.2\text{ mA}$ (Figure 6 and Figure 7)
Input Reverse Breakdown Voltage	BV_R		8	11	—	V	$I_R = 10\text{ }\mu\text{A}$
Logic High Output Voltage	V_{OH}		$V_{DD} - 0.1$	—	—	V	$I_F = 2.2\text{ mA}$, $I_O = -20\text{ }\mu\text{A}$
			$V_{DD} - 1.0$	—	—	V	$I_F = 2.2\text{ mA}$, $I_O = -3.2\text{ mA}$ (Figure 8)
Logic Low Output Voltage	V_{OL}		—	0.001	0.1	V	$I_F = 0\text{ mA}$, $I_O = 20\text{ }\mu\text{A}$
			—	0.15	0.4	V	$I_F = 0\text{ mA}$, $I_O = 3.2\text{ mA}$ (Figure 9)
Input Threshold Current	I_{TH}		—	0.5	1.4	mA	Figure 10
Logic Low Output Supply Current	I_{DDL}	Single	—	0.6	1.1	mA	$V_F = 0\text{V}$, $V_{DD} = 5.5\text{V}$, $I_O = \text{Open}$ (Figure 11)
		Dual	—	1.2	2.2		
Logic High Output Supply Current	I_{DDH}	Single	—	0.5	1.1	mA	$I_F = 2.2\text{ mA}$, $V_{DD} = 5.5\text{V}$, $I_O = \text{Open}$ (Figure 12)
		Dual	—	1.0	2.2		
Input Capacitance	C_{IN}		—	77	—	pF	$f = 1\text{ MHz}$, $V_F = 0\text{V}$
Input Diode Temperature Coefficient	$\Delta V_F / \Delta T_A$		—	-1.9	—	mV/ $^{\circ}\text{C}$	$I_F = 2.2\text{ mA}$

Switching Specifications (AC)

Over recommended temperature ($T_A = -40^\circ\text{C}$ to $+105^\circ\text{C}$), supply voltage ($2.7\text{V} \leq V_{DD} \leq 5.5\text{V}$). All typical specifications are at $V_{DD} = 2.7\text{V}$, $T_A = 25^\circ\text{C}$.

Table 8: Switching Specifications (AC)

Parameter	Symbol	Min.	Typ.	Max.	Units	Test Conditions
Propagation Delay Time to Logic Low Output ^a	t_{PHL}	—	130	250	ns	$I_F = 2.2\text{ mA}$, $C_L = 15\text{ pF}$ (Figure 13, Figure 17), CMOS Signal Levels
Propagation Delay Time to Logic High Output ^a	t_{PLH}	—	115	250	ns	$I_F = 2.2\text{ mA}$, $C_L = 15\text{ pF}$ (Figure 14, Figure 17), CMOS Signal Levels
Pulse Width Distortion ^b	PWD	—	—	200	ns	CMOS Signal Levels
Propagation Delay Skew ^c	t_{PSK}	—	—	220	ns	
Output Rise Time (10% to 90%)	t_R	—	11	—	ns	$I_F = 2.2\text{ mA}$, $C_L = 15\text{ pF}$, CMOS Signal Levels.
Output Fall Time (90% to 10%)	t_F	—	11	—	ns	$I_F = 2.2\text{ mA}$, $C_L = 15\text{ pF}$, CMOS Signal Levels.
Static Common Mode Transient Immunity at Logic High Output ^d	$ CM_H $	25	40	—	kV/ μs	$V_{CM} = 1000\text{V}$, $T_A = 25^\circ\text{C}$, $I_F = 2.2\text{ mA}$, $C_L = 15\text{ pF}$, $V_I = 5\text{V}$, ($R_T = 1.6\text{ k}\Omega$) or $V_I = 3.3\text{V}$, ($R_T = 840\ \Omega$), CMOS Signal Levels, Figure 18
Static Common Mode Transient Immunity at Logic Low Output ^e	$ CM_L $	25	40	—	kV/ μs	$V_{CM} = 1000\text{V}$, $T_A = 25^\circ\text{C}$, $I_F = 0\text{ mA}$, $C_L = 15\text{ pF}$, $V_I = 0\text{V}$, ($R_T = 1.6\text{ k}\Omega$) or ($R_T = 840\ \Omega$), CMOS Signal Levels, Figure 18

- t_{PHL} propagation delay is measured from the 50% (V_{in} or I_F) on the falling edge of the input pulse to the 50% V_{DD} of the falling edge of the V_O signal. t_{PLH} propagation delay is measured from the 50% (V_{in} or I_F) on the rising edge of the input pulse to the 50% level of the rising edge of the V_O signal.
- PWD is defined as $|t_{PHL} - t_{PLH}|$.
- t_{PSK} is equal to the magnitude of the worst case difference in t_{PHL} and/or t_{PLH} that will be seen between units at any given temperature within the recommended operating conditions.
- CM_H is the maximum tolerable rate of rise of the common mode voltage to assure that the output will remain in a high logic state.
- CM_L is the maximum tolerable rate of rise of the common mode voltage to assure that the output will remain in a low logic state.

NOTE: Use of a 0.1- μF bypass capacitor connected between V_{DD} and ground is recommended.

Package Characteristics

All typical at $T_A = 25^\circ\text{C}$.

Table 9: Package Characteristics

Parameter	Symbol	Part Number	Min.	Typ.	Max.	Units	Test Conditions
Input-Output Insulation	V_{ISO}	ACPL-M21L/024L/021L	3750	—	—	V_{rms}	$RH < 50\%$ for 1 min., $T_A = 25^\circ\text{C}$
		ACPL-W21L/K24L	5000	—	—		
Input-Output Resistance	R_{I-O}		—	10^{12}	—	Ω	$V_{I-O} = 500\text{V}$
Input-Output Capacitance	C_{I-O}		—	0.6	—	pF	$f = 1\text{ MHz}$, $T_A = 25^\circ\text{C}$

Figure 6: Forward Voltage vs. Temperature

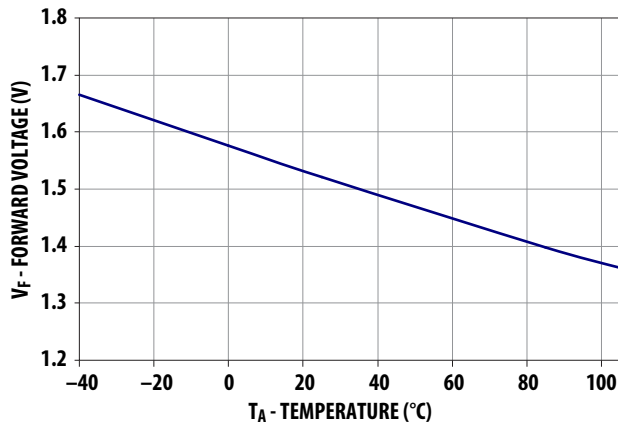

Figure 7: Forward Current vs. Forward Voltage

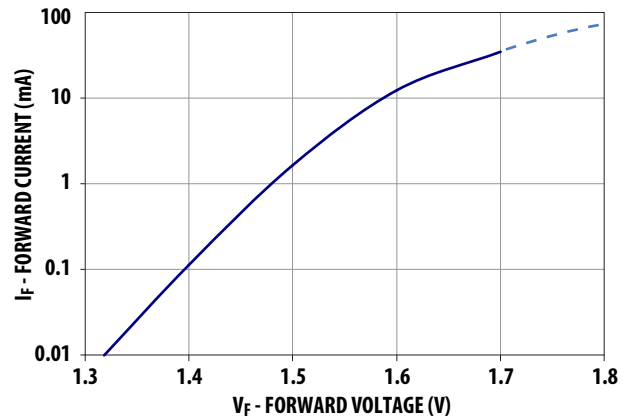

Figure 8: Logic High Output Voltage vs. Supply Voltage

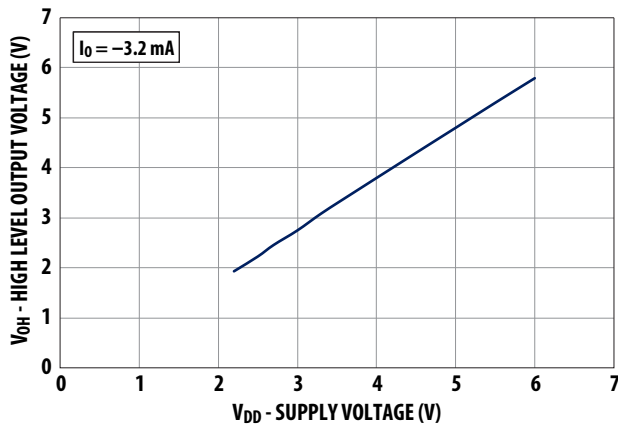

Figure 9: Logic Low Output Voltage vs. Temperature

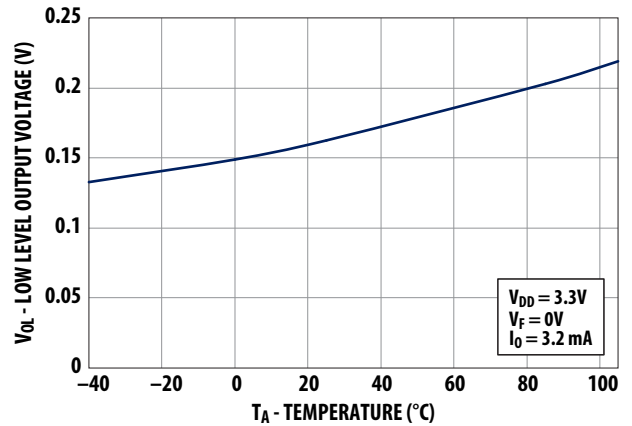

Figure 10: Input Threshold Current vs. Temperature

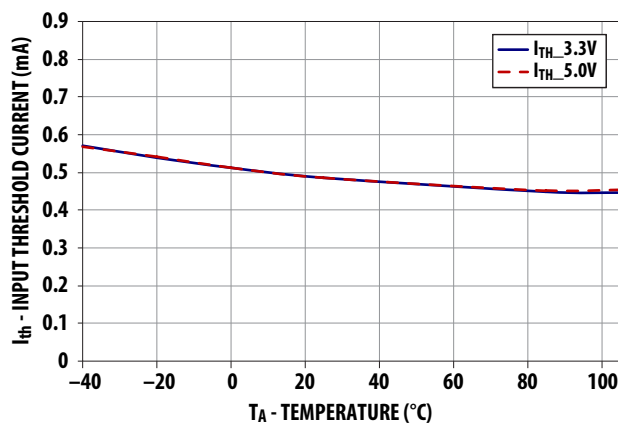

Figure 11: Logic Low Output Supply Current vs. Temperature

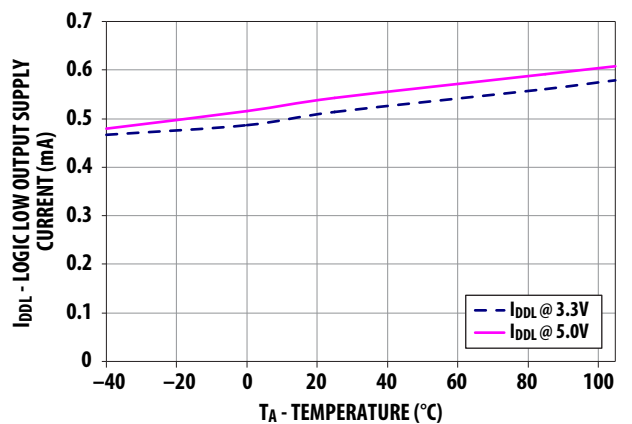

Figure 12: Logic High Output Supply Current vs. Temperature

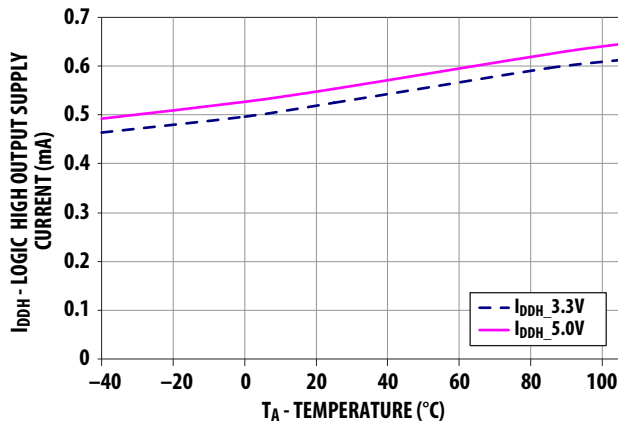

Figure 13: Propagation Delay, t_{PHL} vs. Temperature

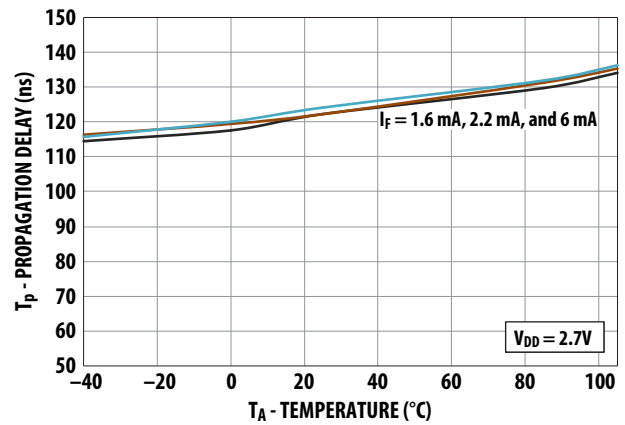

Figure 14: Propagation Delay, t_{PLH} vs. Temperature

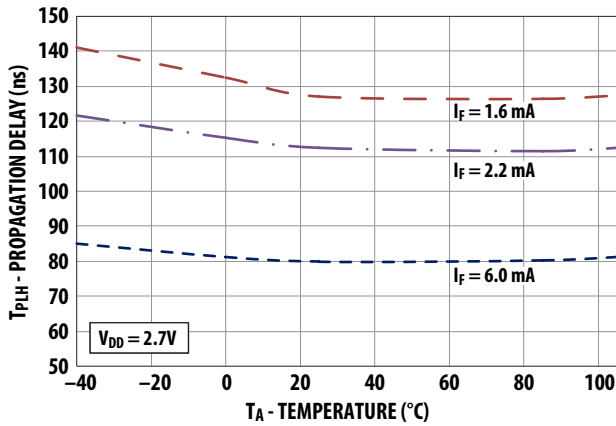

Figure 15: Output Voltage vs. Input Current at V_{DD} = 3.3V

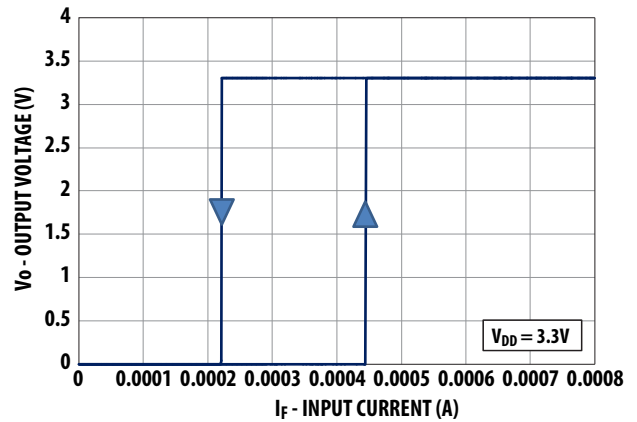

Figure 16: Output Voltage vs. Input Current at V_{DD} = 5V

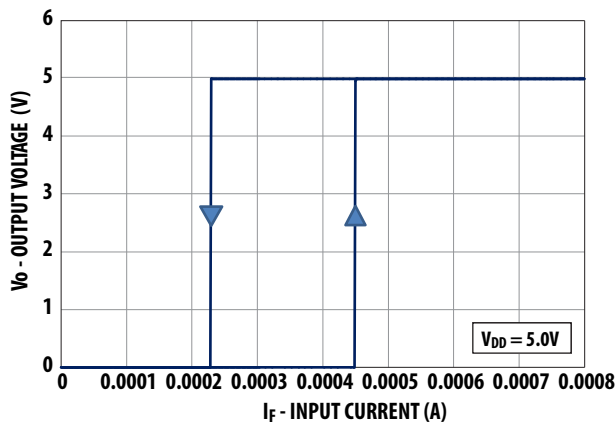
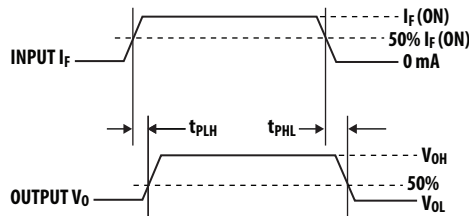
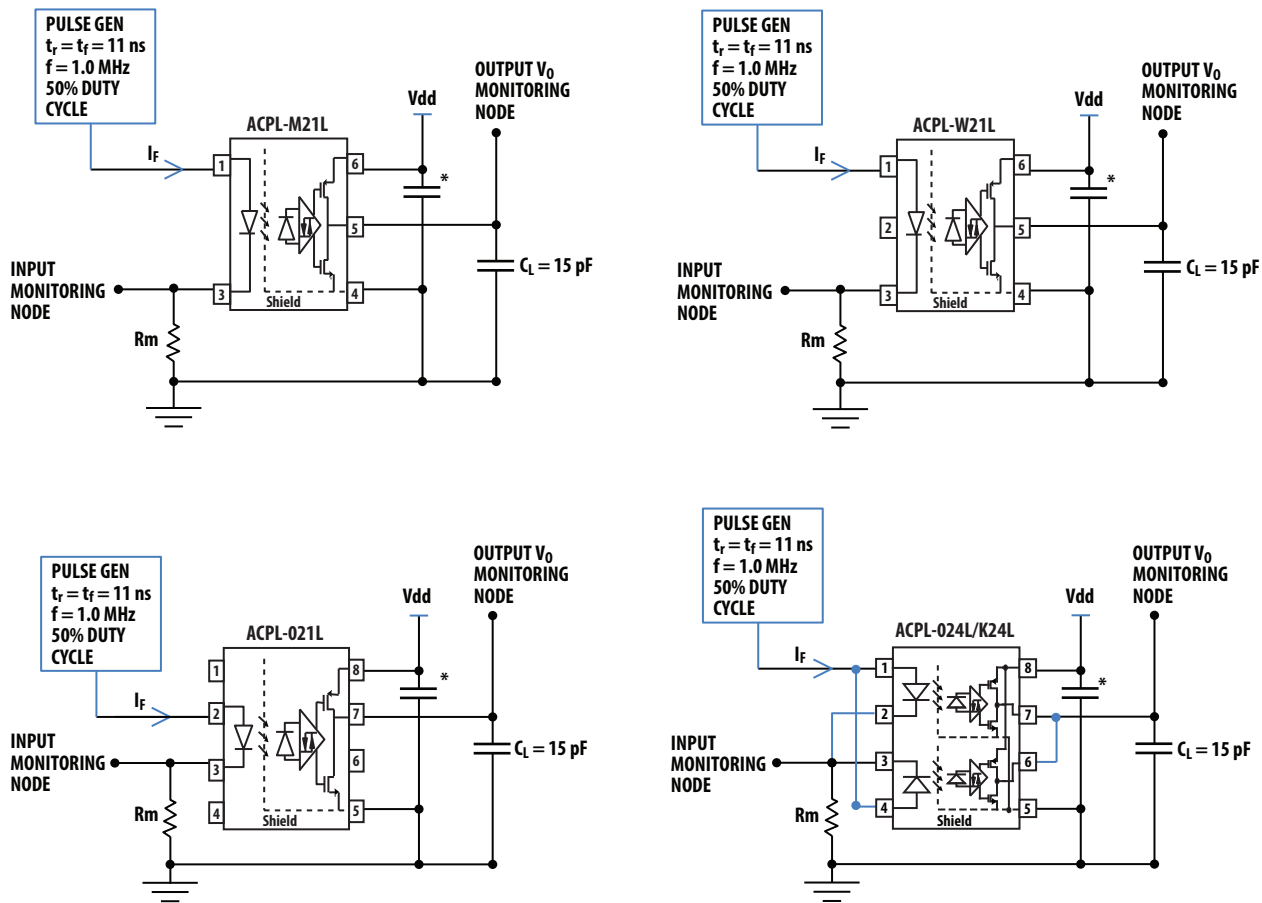

Figure 17: Circuit for t_{PLH} , t_{PHL} , t_r , t_f



* 0.1 μ F BYPASS — SEE NOTE 6 above.^[6]

ACPL-M21L, ACPL-021L, ACPL-024L, ACPL-W21L, ACPL-K24L:

$V_1 = 3.3V$: $R_1 = 510\Omega \pm 1\%$, $R_2 = 330\Omega \pm 1\%$

$V_1 = 5.0V$: $R_1 = 1\text{ k}\Omega \pm 1\%$, $R_2 = 600\Omega \pm 1\%$

$R_T = R_1 + R_2 \approx R_1 / R_2 \approx 1.5$

Figure 18: Recommended Printed Circuit Board Layout and Input Current Limiting Resistor Selection

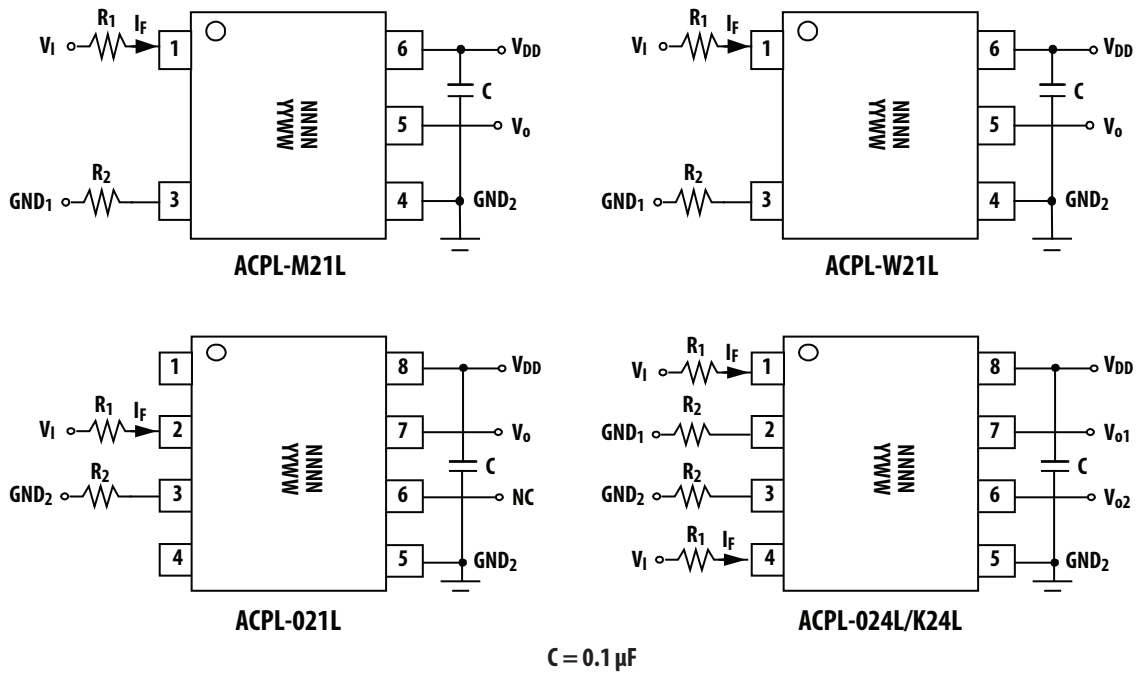

Broadcom, the pulse logo, Connecting everything, Avago Technologies, Avago, and the A logo are among the trademarks of Broadcom and/or its affiliates in the United States, certain other countries, and/or the EU.

Copyright © 2016–2020 Broadcom. All Rights Reserved.

The term “Broadcom” refers to Broadcom Inc. and/or its subsidiaries. For more information, please visit www.broadcom.com.

Broadcom reserves the right to make changes without further notice to any products or data herein to improve reliability, function, or design. Information furnished by Broadcom is believed to be accurate and reliable. However, Broadcom does not assume any liability arising out of the application or use of this information, nor the application or use of any product or circuit described herein, neither does it convey any license under its patent rights nor the rights of others.

