

SIGNAL RELAY

2 POLES - 2A HIGH INSULATION/WIDE GAP

FTR-C1 Series

RoHS Compliant

■ FEATURES

- 2 Poles, 2 form C
- Contact gap: More than 0.6mm
- High surge voltage: 2,500V between open contacts
5,000V between coil & contact
- Complies with Telcordia (former Bellcore) 2nd level surge
- Dielectric strength: 1,500VAC between open contacts
3,000VAC between coil and contact
- Dimensions of large contact gap relay
Height: 9.4mm maximum (THT), 9.7mm maximum (SMT)
Length: 15.2mm maximum
Width: 7.7mm maximum
- Conforms to IEC60950/ EN60950/UL1950/CSA C 22.2 No. 950 working voltage 250V (supplementary)
- High insulation: Clearance: min 2.0mm (coil and contacts)
Creepage: min 2.5mm (coil and contacts)
- Low power consumption 280mW (latching type 140mW)
- RoHS Compliant
- Plastic sealed

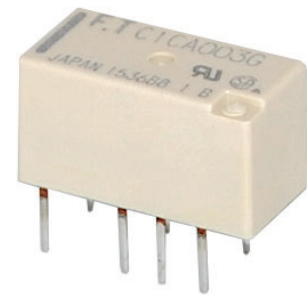

■ APPLICATIONS

xDSL modems, digital multi-function printers (signal switching), STB (line switching), car navigation (audio switching)

■ PART NUMBERS

[Example] FTR-C1 G A 4.5 G - B05
(a) (b) (c) (d) (e) (f)

(a)	Relay type	FTR-C1 series
(b)	Contact configuration	C : Through hole type G : Surface mount type S : Surface mount type reduced mounting area
(c)	Coil type	A : Standard type B : Single coil latching type
(d)	Coil rated voltage	4.5 : 3...24VDC Please refer to coil rating table
(e)	Contact material	G : Gold plated silver palladium (stationary contact) Silver palladium (movable contact)
(f)	Tape/reel version	Nil : Tube packing B05 : Tape & reel packing, only available for surface mount type

Actual marking does not carry the type name : "FTR". E.g.: Ordering code: FTR-C1CA012G Actual marking: C1CA012G

■ SPECIFICATIONS

Item		Specifications		Remarks/Conditions	
		Non-latching FTR-C1()A	Latching FTR-C1()B		
Contact Data	Configuration	2c (2 Form C)			
	Construction	Bifurcated			
	Material	Gold plated silver palladium (stationary contact) Silver palladium (movable contact)			
	Resistance (initial)	Max. 150mΩ		At 1A, 6VDC	
	Contact rating	0.3A, 125VAC/1A, 30VDC		Resistive	
	Max. switching voltage	250VAC/220VDC			
	Max. switching power	62.5VA/30W			
	Max. carrying current	2A			
	Min. switching load *1	0.01mA, 10mVDC		Reference	
Coil	Rated power	280 to 300mW	140 to 180mW		
	Operate power	158 to 162mW	158 to 162mW		
	Pulse width	-	Min. 20ms		
	Operating temperature range	-40°C to +85°C		No frost	
	Storage temperature / humidity	-40°C to +85°C / 5% to 85% RH		No frost	
Time	Operate (at nominal voltage)	Max. 6ms		Without bounce	
	Release (at nominal voltage)	Max. 6ms		Without bounce	
Life	Mechanical	Min. 10 x 10 ⁶ operations			
	Electrical (resistive)	Min. 100 x 10 ³ operations at 0.3A, 125VAC/1A, 30VDC			
Insulation	Insulation resistance	Min. 1,000MΩ		At 500VDC	
	Dielectric strength	Open contacts	1,500VAC (50/60Hz) 1min.		
		Adjacent contacts	1,500VAC (50/60Hz) 1min.		
		Contacts to coil	3,000VAC (50/60Hz) 1min.		
	Surge strength	Contacts to coil	5,000V, 2 x 10μs		
	Clearance	Open contacts	0.6mm		
		Adjacent contacts	1.0mm		
		Contacts to coil	2.0mm		
	Creepage	Open contacts	0.6mm		
		Adjacent contacts	1.0mm		
Contacts to coil		2.5mm			
Other	Vibration resistance	Misoperation>1μs	10 to 55 to 10Hz single amplitude 1.65mm	Coil ON/OFF, 3 axis, total 6 cycles	
		Endurance	10 to 55 to 10Hz single amplitude 2.5mm	Coil OFF, 3 axis, total 6 hours	
	Shock resistance	Misoperation>1μs	Min. 500m/s ² (11±1ms)	Coil ON/OFF, 3 axis, total 36 operations	
		Endurance	Min. 1,000m/s ² (6±1ms)	Coil OFF, 3 axis, total 18 operations	
	Dimensions / Weight	7.5 x 15.0 x 9.3mm / Approximately 2g			
	Sealing	RT III (plastic sealed)			

*1: Minimum switching loads mentioned above are reference values. Please perform the confirmation test with actual load before production since reference values may vary according to switching frequencies, environmental conditions and expected reliability levels.

■ COIL DATA

• Standard (non-latching) type

Coil Code	Rated Coil Voltage (VDC)	Coil Resistance (Ω) $\pm 10\%$	Must Operate Voltage* ¹ (VDC)	Must Release Voltage* ¹ (VDC)	Nominal Coil Power (mW)
003	3	32.1	2.25	0.3	280
4.5	4.5	72.3	3.38	0.45	
005	5	89.3	3.75	0.5	
012	12	514	9.0	1.2	
024	24	1,920	18.0	2.4	300

• Latching type

Coil Code	Rated Coil Voltage (VDC)	Coil Resistance (Ω) $\pm 10\%$	Set Voltage* ¹ (VDC)	Reset Voltage* ¹ (VDC)	Nominal Coil Power (mW)
003	3	64	+2.25	-2.25	140
4.5	4.5	145	+3.38	-3.38	
005	5	179	+3.75	-3.75	
012	12	1,029	+9.0	-9.0	
024	24	3,200	+18.0	-18.0	180

Note: All values in the table are valid for 20°C and zero contact current.

* Specified operate values are valid for pulse wave voltage.

Note: Please use at rated coil voltage. Please perform the confirmation test with actual conditions.

■ SAFETY STANDARDS

Type	Compliance	Contact Rating
UL	Flammability: UL 94-V-0 (plastics)	0.3A, 125 VAC (general use) (UL) 0.5A, 125VAC (CSA)
	UL 508 File No. E63615	
CSA	C22.2 No. 14	2A, 30VDC (general use) 0.3A, 110VDC (general use)
	File No. LR 40304	

■ PART NUMBER LIST

Part Number	Contact configuration	Coil Type	Contact Material	Tape/Reel version	Note	
FTR-C1CA()G	Through hole	Standard	Gold plated silver palladium (stationary contact)	Tube	Tape & reel package is not available	
FTR-C1CB()G		Latching				
FTR-C1GA()G	Surface mount	Standard		Silver palladium (movable contact)	Tube	-
FTR-C1GA()G-B05					Tape & reel	
FTR-C1GB()G		Latching	Tube			
FTR-C1GB()G-B05			Tape & reel			
FTR-C1SA()G	Surface mount reduced mounting area	Standard		Tube	-	
FTR-C1SA()G-B05				Tape & reel		
FTR-C1SB()G		Latching		Tube		
FTR-C1SB()G-B05				Tape & reel		

■ DIMENSIONS

Through hole type

●Dimensions

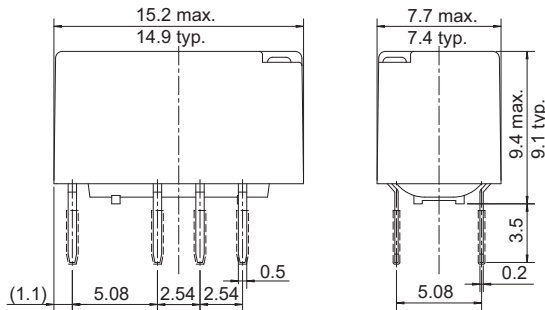

●Schematics (BOTTOM VIEW)

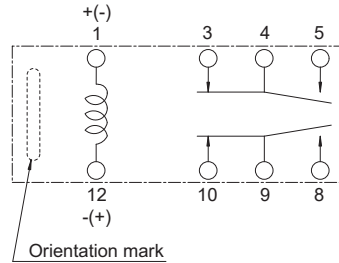

●Recommended PCB layout (BOTTOM VIEW)

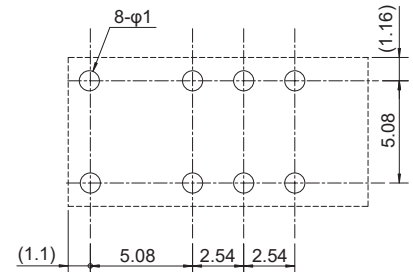

Surface mount type

●Dimensions

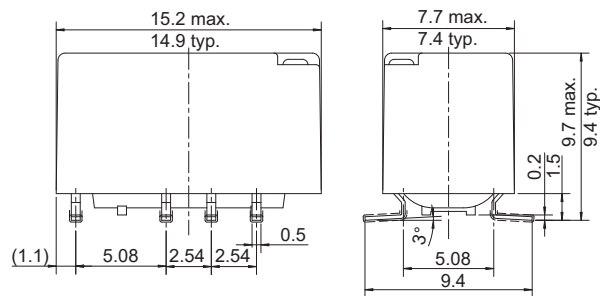

●Schematics (TOP VIEW)

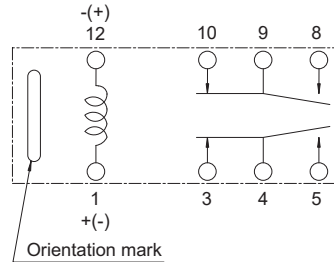

●Recommended PCB layout (TOP VIEW)

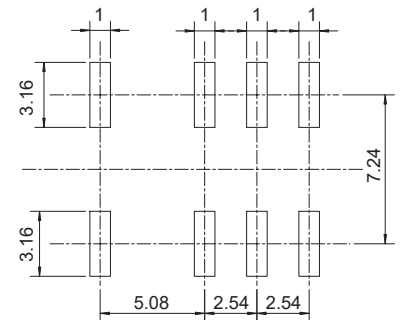

Surface mount (space saving) type

●Dimensions

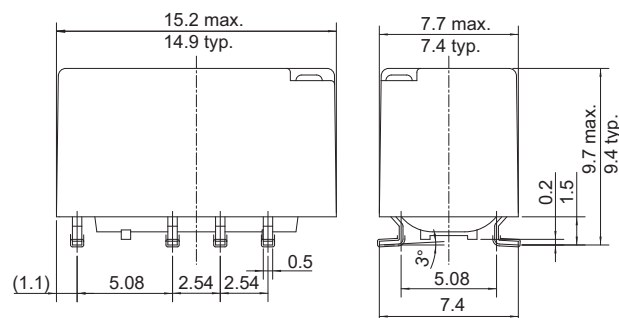

●Schematics (TOP VIEW)

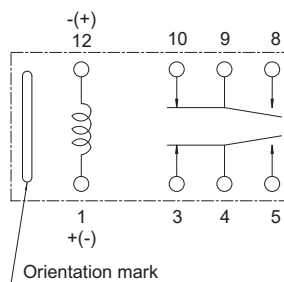

●Recommended PCB layout (TOP VIEW)

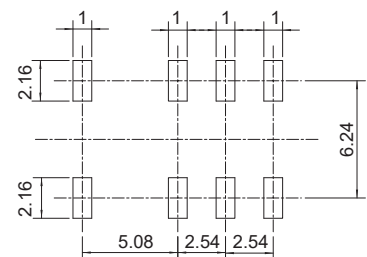

Note: (...) : dimensions are reference

Note: Dimensions of the terminals do not include thickness of pre-soldering.

Note: Dimensions do not include tolerances. Please ask specification in case you need tolerances.

Note: Tolerance of PCB layout: ± 0.1 unless otherwise specified.

Note: +/-: Polarity to apply set voltage, (+)/(-): Polarity to apply reset voltage.

Note: Contacts show de-energized/reset position.

Unit: mm

RECOMMENDED SOLDERING CONDITIONS FOR SURFACE MOUNT TYPE

(Temperature profile, please see page 7)

- Notes:
1. Temperature profiles show the temperature of PC board surface
 2. Please perform soldering test with your actual PC board before mass production, since the temperatures of PC board surfaces vary according to the size of PC board, status of parts mounting and heating method.

TAPE & REEL PACKAGING SPECIFICATION

1. Taping standards: JIS C 0806 and RC-10092B (EIAJ)
2. Tape type: TB2416 or TE2416
3. Reel type: RD24D
4. Quantity of 1 reel: 500 pieces

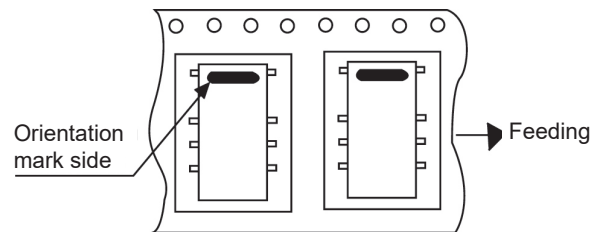

Tape Dimensions:

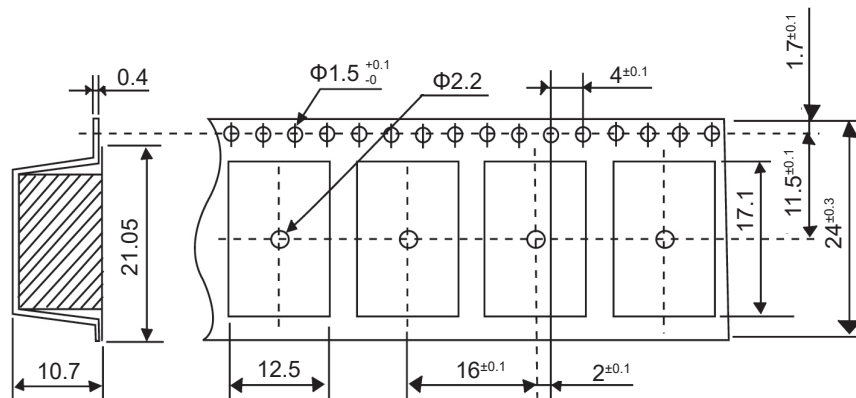

Reel Dimensions:

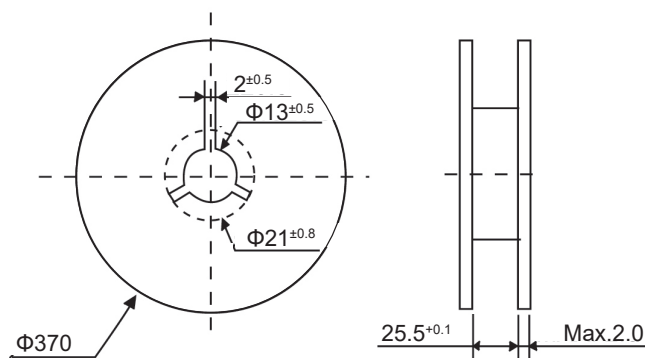

Unit: mm

CHARACTERISTIC DATA

(Characteristic data is not guaranteed value but measured values of samples from production line.)

Distribution of operate/release voltage



Distribution of operate time

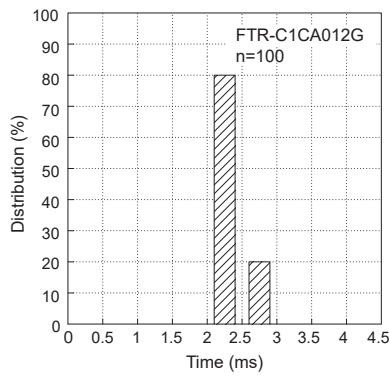

Distribution of release time

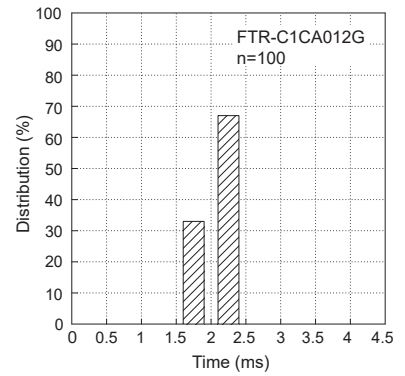

Set/reset time characteristics

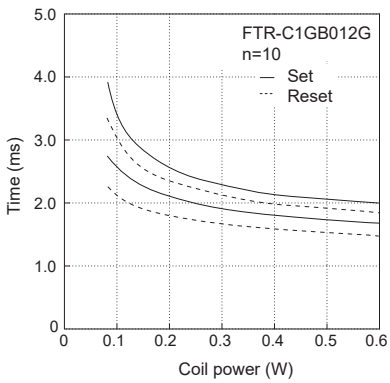

Pulse characteristics

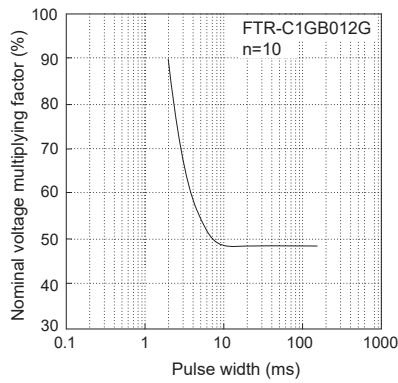

Distribution of contact resistance (Make contacts)

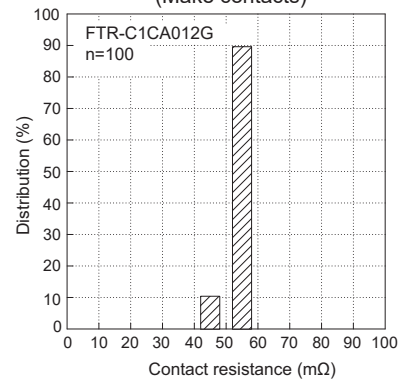

Distribution of contact resistance (Break contacts)

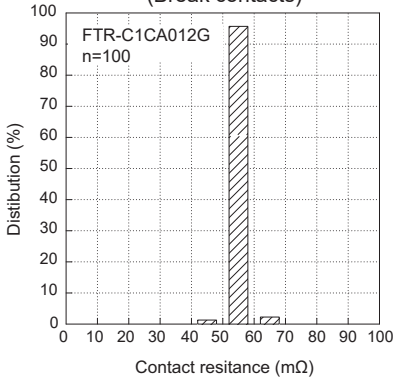

Maximum switching power

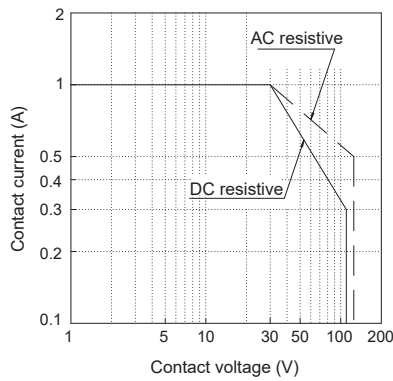

Life curve

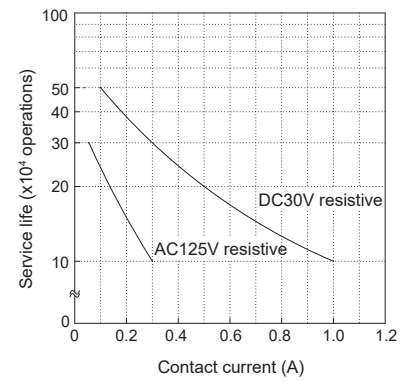

Operating range

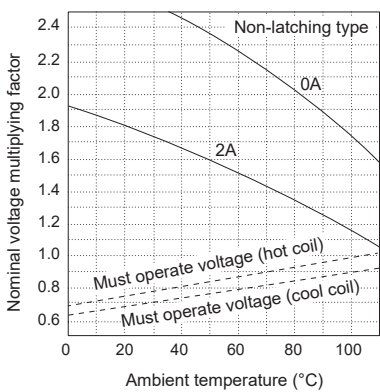

Operating range

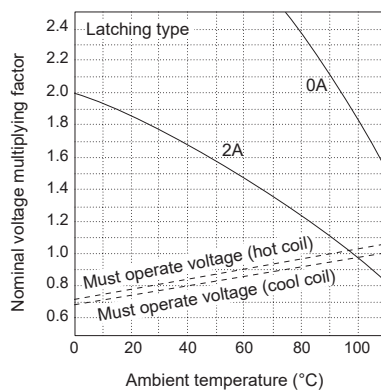

Coil temperature rise

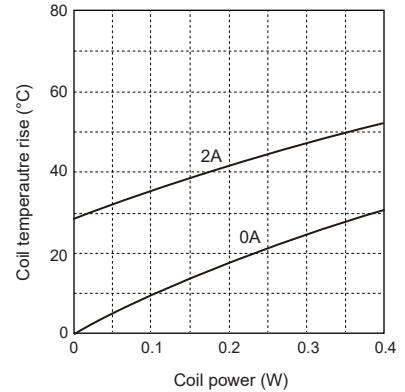

CAUTIONS

- All values mentioned in this datasheet are provided under ideal conditions. Please perform the confirmation test before actual use.
- Reflow soldering is not available with through hole type.
- Do not use relays in the atmosphere with sulfide gas, chloride gas or nitric oxide. Contact resistance may increase.
- Do not use silicon or silicon-containing product or materials near relays. It may cause contact failure.

Notes for latching relays

- Latching relays are shipped in the state reset, but state may change due to shock during transportation or mounting. Before using the relays, it is advisable to bring the relays in necessary state (set or reset) and program a circuit sequence. Otherwise, it will or will not operate simultaneously with power activation.
- Please connect relay coils according to specified polarity.
- Do not apply voltage to both set coil and reset coil at a time.

GENERAL INFORMATION

1. RoHS Compliance

- All relays produced by FCL Components are compliant with RoHS directive 2011/65/EU, including commission delegated directive 2015/863.

2. Recommended lead free solder condition

Flow Solder Condition:

Pre-Heating: Maximum 120°C within 90 sec.
Soldering: Dip within 5 sec. at 255°C±5°C solder bath

Relay must be cooled by air immediately after soldering

Solder by Soldering Iron:

Soldering Iron: 30-60W
Temperature: Maximum 350-360°C
Duration: Maximum 3 sec.

Reflow Solder Condition: (Applicable only for reflow capable type)

Recommended reflow soldering profile: IRS (infrared reflow soldering)

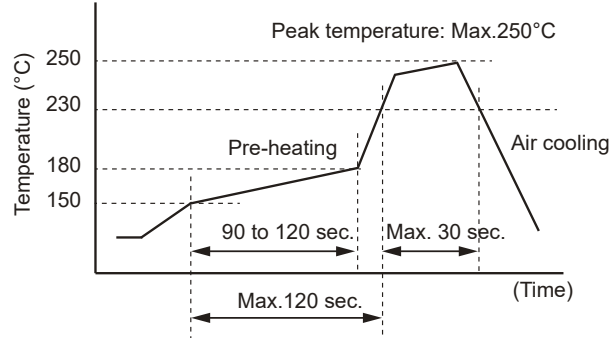

Important notes for reflow soldering

- Temperature shall be measured at PC board upper surface.
- Temperature at PC board upper surface may be changed depending on size of PC board, components mounted on the PC board and/or heating method. Please perform the confirmation test with actual PC board.
- This reflow condition is applicable only for reflow-capable relays. Do not reflow reflow-incapable relays.
- Recommended solder for assembly: Sn-3.0 Ag -0.5 Cu.

We highly recommend that you confirm your actual solder conditions

3. Moisture Sensitivity

- SMT versions of FTR-C1 relays in Tape & Reel package will be shipped in Moisture Barrier Bag (MBB).
- Moisture Sensitivity Level (MSL) of FTR-C1 relay is indicated on the packing caution label.
- Relays must be stored in the unopened MBB at storage conditions <40°C/90% RH for a maximum 1 year.
- SMT versions of FTR-C1 relays in tube packing will not be shipped in MBB. Therefore, these relays shall be dried by baking before reflow soldering process according to IPC/Jedex J-STD-033.

4. Tin Whiskers

- Dipped SnAgCu solder is known as presenting a low risk to tin whisker development. No considerable length whisker was found by our in-house test.

Contact

Japan

FCL COMPONENTS LIMITED
Shinagawa Seaside Park Tower
12-4, Higashi-shinagawa 4-chome,
Tokyo 140 0002, Japan
Tel: +81-3-3450-1682
Email: fcl-contact@cs.fcl-components.com

North and South America

FCL COMPONENTS AMERICA, INC.
2055 Gateway Place Suite 480,
San Jose, CA 95110 USA
Tel: +1-408-745-4900
Email: contact@fcl-components.us

Europe

FCL COMPONENTS EUROPE B.V.
Diamantlaan 25
2132 WV Hoofddorp, Netherlands
Tel: +31-23-556-0910
Email: info@fcl-components.eu

Asia Pacific

FCL COMPONENTS ASIA PTE LTD.
51 Changi Business Park Central 2, #06-07
The Signature Singapore 486066
Tel: +65-6375-8560
Email: fcals@fcl-components.com

China

FCL COMPONENTS (SHANGHAI) CO.,LTD.
Unit 1105, Central Park - Jing An,
No.329 Heng Feng Road, Shanghai
200070, China
Tel: +86-21-3253 0998
Email: fcsh@fcl-components.com

Hong Kong

FCL COMPONENTS HONG KONG CO.,
LIMITED
Unit 2313, Seapower Tower, Concordia
Plaza, No.1 Science Museum Road,
TST, Kowloon, Hong Kong
Tel: +852-2881-8495
Email: fcals@fcl-components.com

Web: www.fcl-components.com/en/

© 2026 FCL Components Limited. All rights reserved. All trademarks or registered trademarks are the property of their respective owners.

FCL Components Products are intended for general use, including without limitation, in personal, household and office environments, in buildings and for ordinary use in the industry. FCL Components Products are not intended to be used in applications where extremely high safety is required ("High Safety Required Applications"), such as, but not limited to, applications in nuclear facilities, in aircraft automatic flight control, in air traffic control, in mass transit system control, in missile launch system, in weapon systems, in medical equipment for life support or any application involving a direct serious risk of physical injury or death.

Please do not use FCL Components Products without securing the sufficient safety and reliability required for the High Safety Required Applications.

In addition, FCL Components shall not be liable against the customer and/or any third party for any claims or damages arising in connection with the use of FCL Components Products in the High Safety Required Applications.

FCL Components warrants that its Products, if properly used and services, will conform to their specification and will be free from defects in material and workmanship for twelve months from delivery.

The implied warranties of merchantability and fitness for a particular purpose and all other warranties, representations and conditions, express or implied by statute, trade usage or otherwise, except as set forth in this warranty, are excluded and shall not apply to the Products delivered.

The contents, data and information in this datasheet are provided by FCL Components Limited as a service only to its user and only for general information purposes. The use of the contents, data and information provided in this datasheet is at the users' own risk.

FCL Components has assembled this datasheet with care and will endeavor to keep the contents, data and information correct, accurate, comprehensive, complete and up to date.

FCL Components Limited and affiliated companies do however not accept any responsibility or liability on their behalf, nor on behalf of its employees, for any loss or damage, direct, indirect or consequential, with respect to this datasheet, its contents, data, and information and related graphics and the correctness, reliability, accuracy, comprehensiveness, usefulness, availability and completeness thereof. Nor do FCL Components Limited and affiliated companies accept on their behalf, nor on behalf of its employees, any responsibility or liability with respect to these datasheets, its contents, data, information and related graphics and the correctness, reliability, accuracy, comprehensiveness, usefulness, availability and completeness thereof. Rev. May 19, 2026.