



## Features

- Universal Input Range 90~264Vac
- 2"x 4" Size
- 180W with Natural Convection  
@220Vac/CFM200M
- 200W with Natural Convection  
@220Vac/CFM200MXXXC
- Active PFC Meets EN61000-3-2
- No Load Power Consumption<0.3W
- High Power Density up to 16.9W/Inch<sup>3</sup>/CFM200M
- +12V Fan Output
- High Efficiency up to 93.5%
- IEC/EN/UL 60601-1 2MOPP Approval
- Meets Class I & Class II

# CFM200M SERIES

## 200 WATT AC-DC POWER SUPPLY WITH PFC



MODEL	VOLTAGE OUTPUT	OUTPUT CURRENT	RIPPLE & NOISE NOTE 1	VOLTAGE ACCURACY NOTE 2	LINE REG. NOTE 3	LOAD REG. NOTE 4	% EFF. (Typ.) NOTE 5
Main Output Voltage							
CFM200M120	+12V	16.67A	150mVp-p	±2.0%	±0.5%	±1%	92%
CFM200M240	+24V	8.33A	240mVp-p	±2.0%	±0.5%	±1%	93.5%
CFM200M480	+48V	4.17A	480mVp-p	±2.0%	±0.5%	±1%	93%
Fan Output Voltage							
All	+12V	0.5A NOTE 6	—	—	—	—	—

## PART NUMBER

Series	Number of Outputs	Nominal Output Voltage	Type
CFM200	O	XXX	Y (Option)
CFM200	M : Medical	120 : 12VDC 240 : 24VDC 480 : 48VDC	None: With Baseplate C: With Cover

Part Number Example:

**CFM200M120:** With Baseplate, 200W, 12Vdc Output

**CFM200M120C:** With Case, 200W, 12Vdc Output

Typical at 25°C, 230Vac and 60% rated load, unless otherwise specified

## Specifications

### INPUT SPECIFICATIONS:

Voltage .....	90~264V <sub>ac</sub> 120~370V <sub>dc</sub>
Frequency .....	47 to 63Hz
Inrush Current .....	100A max. @240V <sub>ac</sub>
Leakage Current (Earth) .....	260uA typ., 300uA max.
Touch Current (CFM200MXXXC) .....	75uA typ., 100uA max.

### OUTPUT SPECIFICATIONS:

Total Rated Output Power .....	200W
Hold-up Time .....	10ms typ.
Over Voltage Protection .....	Recycle AC Input to Rest
Short Circuit Protection .....	Hiccup Mode (Auto Recovery)
Temperature Coefficient .....	±0.05%/°C max.

### GENERAL SPECIFICATIONS:

Isolation .....	Input to Output = 4000V <sub>ac</sub>
Over Temperature Protection .....	Auto Recovery
Operating Temperature .....	- 20 ~ 80°C (See Derating Curve)
Storage Temperature .....	-40~85°C
Humidity .....	93% RH max. Non Condensing
Switching Frequency .....	85KHz Typical
MTBF .....	MIL-HDBK-217F, GB, 25°C/115V <sub>ac</sub> ..... 279khrs typ.
Altitude .....	3000m
Dimensions	
with Baseplate Versions .....	4.000x2.000x1.480 Inches (101.60x50.80x37.60 mm)
Covered Versions .....	4.606x2.441x1.594 Inches (117.00x62.00x40.50 mm)
Weight	
with Baseplate Versions .....	253g (0.558 Pounds)
Covered Versions .....	314g (0.692 Pounds)

### SAFETY AND EMC:

Emission and Immunity .....	EN60601-1-2:2015 ed. 4.0 EN55011 Class B, FCC CFR 47 part 18 IEC61000-3-2, 3, IEC61000-4-2, 3, 4, 5, 6, 8, 11
Safety .....	Class I & Class II, IEC60601-1:2005+A1:2012 ed 3.1 EN60601-1:2006+A11:2011+A1+A12 ed 3.1, UL ANSI/AAMI ES60601-1

### NOTE:

1. Add a 0.1uF ceramic capacitor and a 47uF E.L. capacitor to output for ripple&noise measuring @20MHz BW.
2. Voltage accuracy is set at 60% rated load and 25°C Ta.
3. Line regulation is measured from high line to low line with rated load.
4. Load regulation is measured from full to 10% rated.
5. Typical efficiency at 230 VAC and full load at 25°C.
6. 12V/0.3A with nature convection; 12V/0.5A with 10 CFM air flow, tolerance ±10% at main output 10-100% full load.
7. Need an external 1mH choke at input for Class II type to pass EN55011 Class B.

## CFM200M Series De-Rating Curve

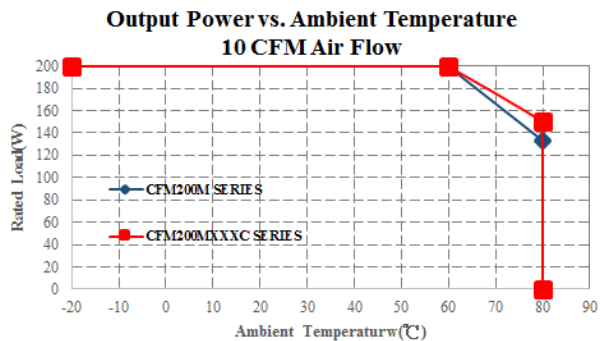
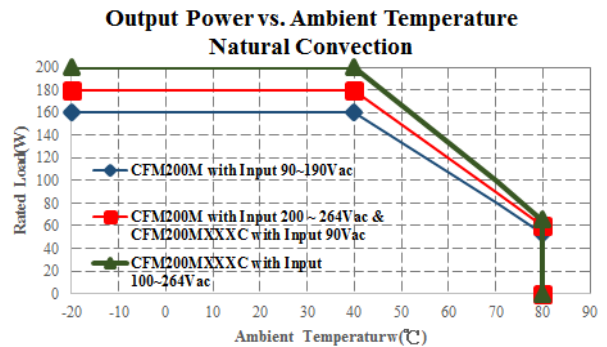
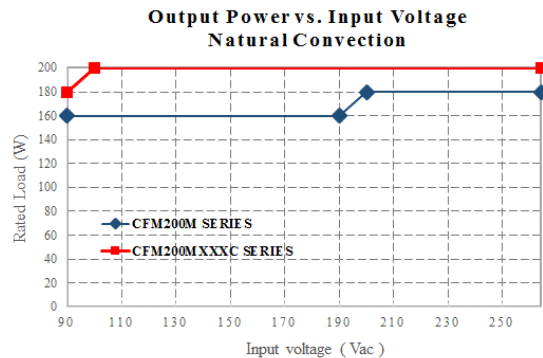

8. Input connectors (CN1) wafer with TAIWAN KING PIN TERMINAL PVHI series and mate with JST Housing VHR series or equivalent.
9. Fan output connector wafer with TOWNES ENTERPRISE 2001BW series and mate with JST Housing PHR series and JST SPH series crimp terminal or equivalent.
10. Output connectors (Vo+ & Vo- with M3 screw) mate with round terminal and round terminal of the max outer diameter is 6.75mm, max inner diameter is 3.9mm.

# Mechanical Specification

CFM200MXXX

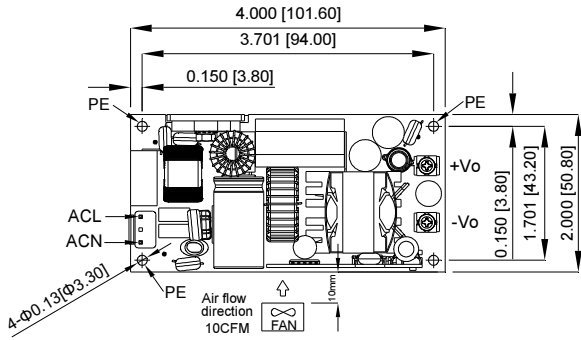

All Dimensions In Inches(mm)  
Tolerance Inches:x.xxx=±0.02  
Millimeters:x.xx=±0.5

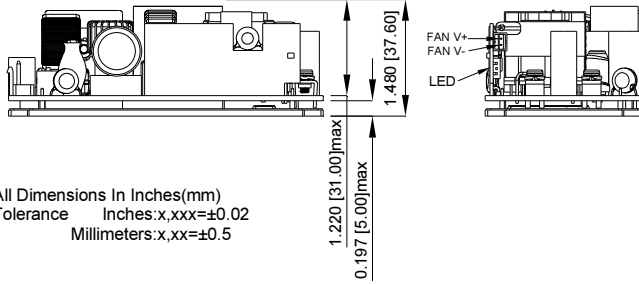

CFM200MXXXC

