

## DESCRIPTION

The MPM3610A is a synchronous rectified, step-down module converter with built-in power MOSFETs, inductor, and two capacitors. It offers a very compact solution, requires only 5 external components to achieve a 1.2A continuous output current with excellent load and line regulation over a wide input supply range and provides fast load transient response.

Full protection features include over-current protection and thermal shut-down.

MPM3610A eliminates design and manufacturing risks while dramatically improving time-to-market.

The MPM3610A is available in a space-saving QFN20 (3mmx5mmx1.6mm) package.

## FEATURES

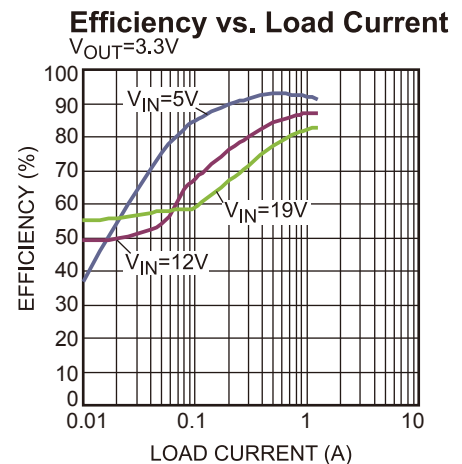
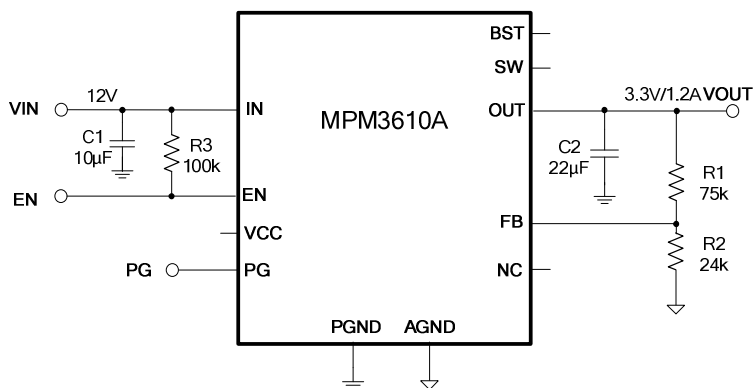
- 4.5V-to-21V Operating Input Range
- 1.2A Continuous Load Current
- 90mΩ/40mΩ Low  $R_{DS(ON)}$  Internal Power MOSFETs
- Integrated Inductor
- Integrated VCC and Bootstrap Capacitors
- Power Save Mode at Light Load
- Power Good Indicator
- OCP Protection and Hiccup
- Thermal Shutdown
- Output Adjustable from 0.8V
- Available in QFN20 (3x5x1.6mm) Package
- Total solution size 6.7mm x7.3mm

## APPLICATIONS

- Industrial Controls
- Medical and Imaging Equipment
- Telecom and Networking Applications
- LDO Replacement
- Space and Resource-limited Applications

All MPS parts are lead-free and adhere to the RoHS directive. For MPS green status, please visit MPS website under Products, Quality Assurance page. "MPS" and "The Future of Analog IC Technology" are registered trademarks of Monolithic Power Systems, Inc.

## TYPICAL APPLICATION



## ORDERING INFORMATION

Part Number*	Package	Top Marking
MPM3610AGQV	QFN-20 (3mmx5mmx1.6mm)	See Below

\* For Tape & Reel, add suffix -Z (e.g. MPM3610AGQV-Z);

## TOP MARKING

MPYW

3610

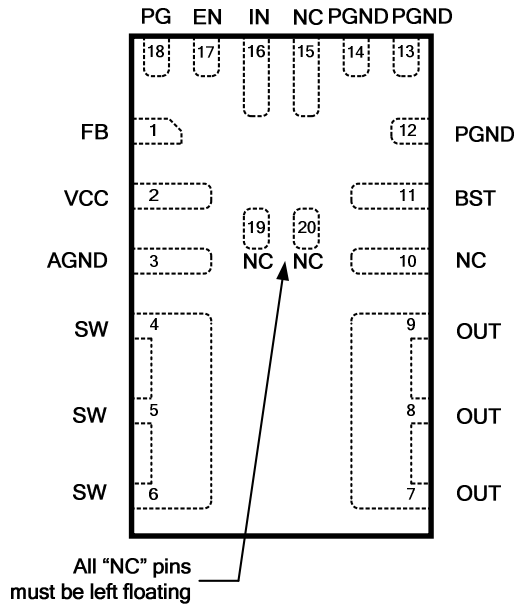
ALLL

M

MP: MPS prefix;  
Y: year code;  
W: week code;  
3610A: first five digits of the part number;  
LLL: lot number;  
M: module;

**PACKAGE REFERENCE**

**TOP VIEW**



**ABSOLUTE MAXIMUM RATINGS <sup>(1)</sup>**

$V_{IN}$ .....	-0.3V to 28V
$V_{SW}$ .....	-0.3V (-5V for <10ns) to 28V (30V for <10ns)
$V_{BST}$ .....	$V_{SW} + 6V$
All Other Pins .....	-0.3V to 6V <sup>(2)</sup>
Continuous Power Dissipation ( $T_A = +25^\circ C$ ) <sup>(3)</sup>	2.7W
Junction Temperature .....	150°C
Lead Temperature .....	260°C
Storage Temperature .....	-65°C to 150°C

**Recommended Operating Conditions <sup>(4)</sup>**

Supply Voltage $V_{IN}$ .....	4.5V to 21V
Output Voltage $V_{OUT}$ .....	0.8V to $V_{IN} \cdot D_{MAX}$ <sup>(5)</sup>
Operating Junction Temp. ( $T_J$ ) .....	-40°C to +125°C

<b>Thermal Resistance <sup>(6)</sup></b>	$\theta_{JA}$	$\theta_{JC}$
QFN-20 (3mmx5mmx1.6mm)	46 .....	10 ... °C/W

**Notes:**

- 1) Exceeding these ratings may damage the device.
- 2) About the details of EN pin's ABS MAX rating, please refer to page 14, Enable control section.
- 3) The maximum allowable power dissipation is a function of the maximum junction temperature  $T_J$  (MAX), the junction-to-ambient thermal resistance  $\theta_{JA}$ , and the ambient temperature  $T_A$ . The maximum allowable continuous power dissipation at any ambient temperature is calculated by  $P_D$  (MAX) =  $(T_J$  (MAX) -  $T_A$ ) /  $\theta_{JA}$ . Exceeding the maximum allowable power dissipation will cause excessive die temperature, and the regulator will go into thermal shutdown. Internal thermal shutdown circuitry protects the device from permanent damage.
- 4) The device is not guaranteed to function outside of its operating conditions.
- 5) In practical design, the minimum  $V_{OUT}$  is limited by minimum on time, 50ns on time is commonly recommended for calculating to give some margin. For output voltage setting above 5.5V, please refer to the application information on page 17.
- 6) Measured on JESD51-7, 4-layer PCB.

## ELECTRICAL CHARACTERISTICS

$V_{in}=12V$ ,  $T_J=-40^{\circ}C$  to  $+125^{\circ}C$ <sup>(7)</sup>, typical value is tested at  $T_J=+25^{\circ}C$ , unless otherwise noted.

Parameter	Symbol	Condition	Min	Typ	Max	Units
Supply Current (Shutdown)	$I_s$	$V_{EN} = 0V$ , $T_J = +25^{\circ}C$		6.5	8	$\mu A$
		$V_{EN} = 0V$ , $T_J = -40^{\circ}C$ to $+125^{\circ}C$		6.5	9	$\mu A$
Supply Current (Quiescent)	$I_q$	$V_{FB} = 1V$ , $T_J = +25^{\circ}C$		0.3	0.39	mA
		$V_{FB} = 1V$ , $T_J = -40^{\circ}C$ to $+125^{\circ}C$		0.3	0.44	mA
HS Switch-On Resistance	$HS_{RDS-ON}$	$V_{BST-SW}=5V$		90		m $\Omega$
LS Switch-On Resistance	$LS_{RDS-ON}$	$V_{CC} = 5V$		40		m $\Omega$
Inductor DC Resistance	$L_{DCR}$			60		m $\Omega$
Switch Leakage	$SW_{LKG}$	$V_{EN} = 0V$ , $V_{SW} = 12V$			1	$\mu A$
Current Limit	$I_{LIMIT}$	Under 40% Duty Cycle	2.3	3		A
Oscillator Frequency	$f_{SW}$	$V_{FB}=0.75V$ , $T_J = +25^{\circ}C$	1600	2000	2400	kHz
		$V_{FB}=0.75V$ , $T_J = -40^{\circ}C$ to $+125^{\circ}C$	1500	2000	2500	kHz
Fold-Back Frequency	$f_{FB}$	$V_{FB}=200mV$		0.3		$f_{SW}$
Maximum Duty Cycle	$D_{MAX}$	$V_{FB}=700mV$ , $T_J = +25^{\circ}C$	78	83	88	%
		$V_{FB}=700mV$ , $T_J = -40^{\circ}C$ to $+125^{\circ}C$	77	83	89	%
Minimum On Time <sup>(8)</sup>	$T_{ON\_MIN}$			30		ns
Feedback Voltage	$V_{FB}$	$T_J = 25^{\circ}C$	786	798	810	mV
		$T_J = -40^{\circ}C$ to $+125^{\circ}C$	782	798	814	mV
Feedback Current	$I_{FB}$	$V_{FB}=820mV$		10	50	nA
EN Rising Threshold	$V_{EN\_RISING}$	$T_J = +25^{\circ}C$	1.2	1.4	1.6	V
		$T_J = -40^{\circ}C$ to $+125^{\circ}C$	1.15	1.4	1.65	V
EN Falling Threshold	$V_{EN\_FALLING}$	$T_J = +25^{\circ}C$	1.05	1.25	1.4	V
		$T_J = -40^{\circ}C$ to $+125^{\circ}C$	1	1.25	1.45	V
EN Input Current	$I_{EN}$	$V_{EN}=2V$ , $T_J = +25^{\circ}C$	2	2.3	2.6	$\mu A$
		$V_{EN}=2V$ , $T_J = -40^{\circ}C$ to $+125^{\circ}C$	1.8	2.3	2.8	$\mu A$
Power Good Rising Threshold	$PG_{VTH-HI}$	$T_J = +25^{\circ}C$	0.86	0.9	0.95	$V_{FB}$
Power Good Falling Threshold	$PG_{VTH-LO}$	$T_J = +25^{\circ}C$	0.78	0.83	0.88	$V_{FB}$
Power Good Rising Delay	$PG_{TD\_RSING}$	$T_J = +25^{\circ}C$	15	35	55	$\mu s$
		$T_J = -40^{\circ}C$ to $+125^{\circ}C$	10	35	60	$\mu s$
Power Good Falling Delay	$PG_{TD\_FALLING}$	$T_J = +25^{\circ}C$	40	80	125	$\mu s$
		$T_J = -40^{\circ}C$ to $+125^{\circ}C$	30	80	135	$\mu s$
Power Good Sink Current Capability	$V_{PG}$	Sink 1mA			0.4	V
Power Good Leakage Current	$I_{PG-LEAK}$	$V_{PG}=6V$			1	$\mu A$

**ELECTRICAL CHARACTERISTICS***(continued)*
**V<sub>IN</sub>=12V, T<sub>J</sub>=-40°C to +125°C, typical value is tested at T<sub>J</sub>=+25°C, unless otherwise noted.**

Parameter	Symbol	Condition	Min	Typ	Max	Units
VIN Under-Voltage Lockout Threshold—Rising	INUV <sub>Vth</sub>	T <sub>J</sub> =+25°C	3.7	3.9	4.1	V
		T <sub>J</sub> =-40°C to +125°C	3.65	3.9	4.15	V
VIN Under-Voltage Lockout Threshold—Hysteresis	INUV <sub>HYS</sub>		600	675	750	mV
VCC Regulator	V <sub>CC</sub>	T <sub>J</sub> =+25°C	4.75	4.9	5.05	V
		T <sub>J</sub> =-40°C to +125°C	4.7	4.9	5.1	V
VCC Load Regulation		I <sub>CC</sub> =5mA		1.5	3	%
Soft-Start Time	t <sub>SS</sub>	V <sub>OUT</sub> from 10% to 90%, T <sub>J</sub> =+25°C	0.8	1.6	2.4	ms
		V <sub>OUT</sub> from 10% to 90%, T <sub>J</sub> =-40°C to +125°C	0.6	1.6	2.6	ms
Thermal Shutdown <sup>(8)</sup>	T <sub>SD</sub>			150		°C
Thermal Hysteresis <sup>(8)</sup>	T <sub>SD_HYS</sub>			20		°C

**Notes:**

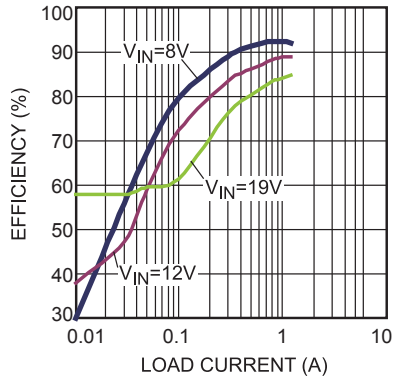
7) Not tested in production. Guaranteed by over-temperature correlation.

8) Guaranteed by Characterization.

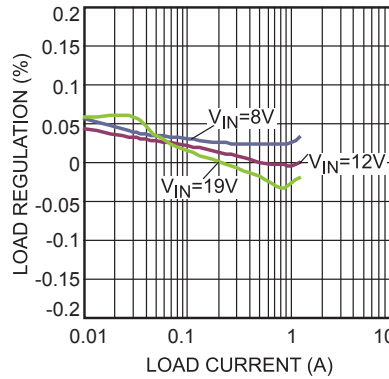
## TYPICAL CHARACTERISTICS

$V_{IN} = 12V$ ,  $V_{OUT} = 3.3V$ ,  $T_A = 25^\circ C$ , unless otherwise noted.

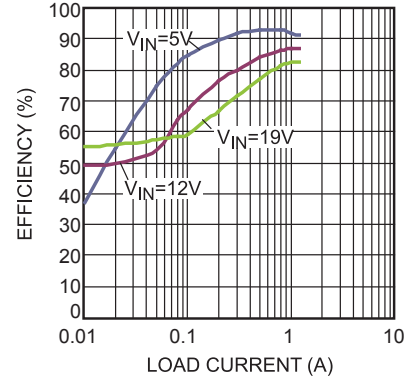
**Efficiency vs. Load Current**  
 $V_{OUT}=5V$



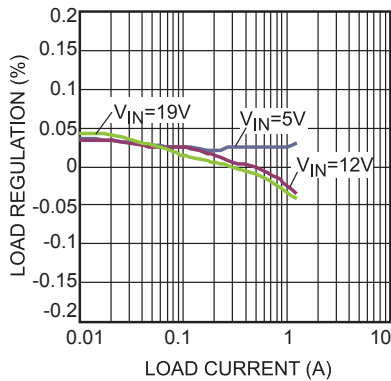
**Load Regulation**  
 $V_{OUT}=5V$



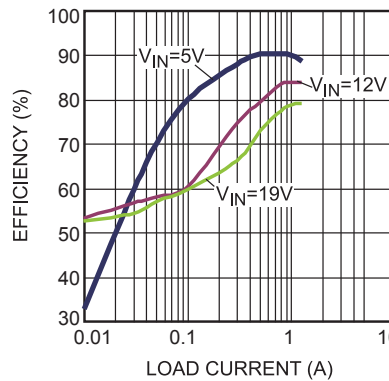
**Efficiency vs. Load Current**  
 $V_{OUT}=3.3V$



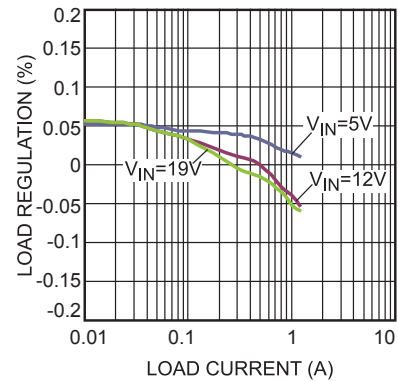
**Load Regulation**  
 $V_{OUT}=3.3V$



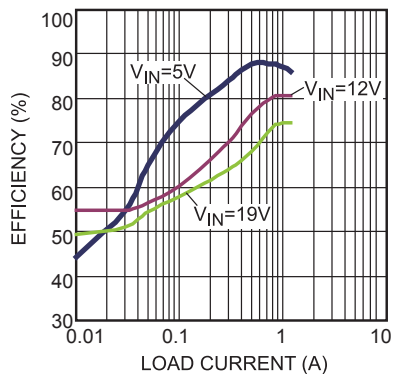
**Efficiency vs. Load Current**  
 $V_{OUT}=2.5V$



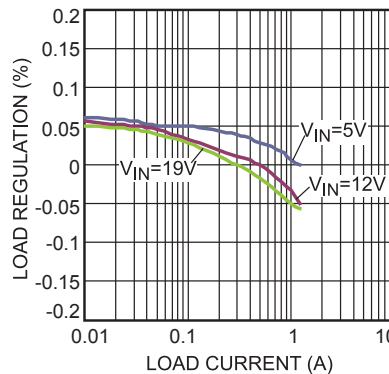
**Load Regulation**  
 $V_{OUT}=2.5V$



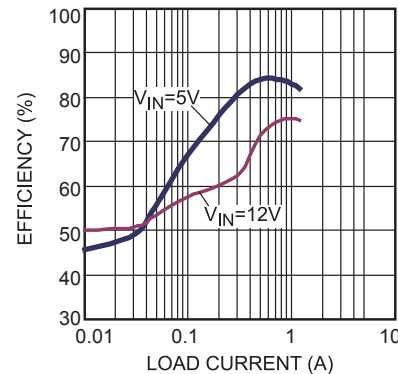
**Efficiency vs. Load Current**  
 $V_{OUT}=1.8V$



**Load Regulation**  
 $V_{OUT}=1.8V$

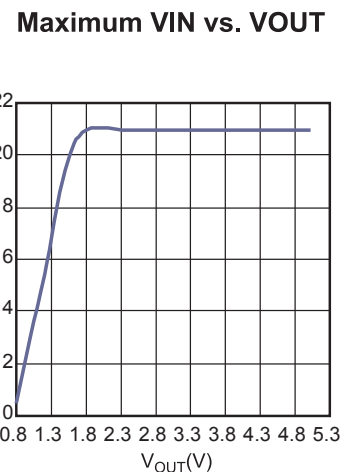
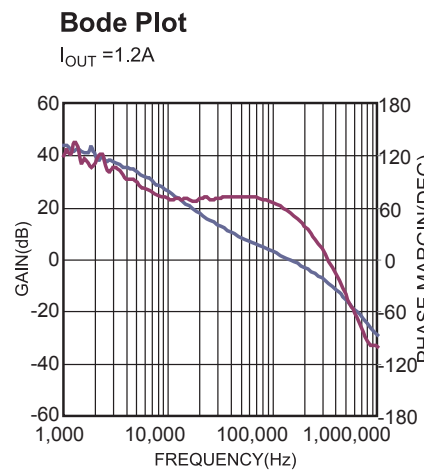
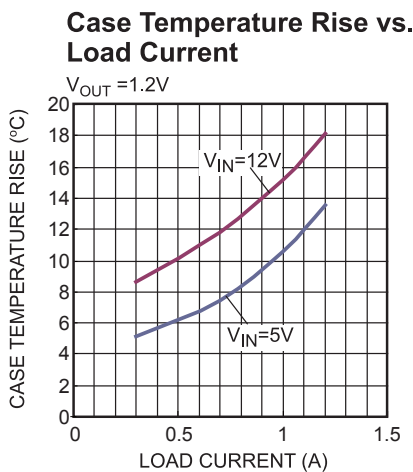
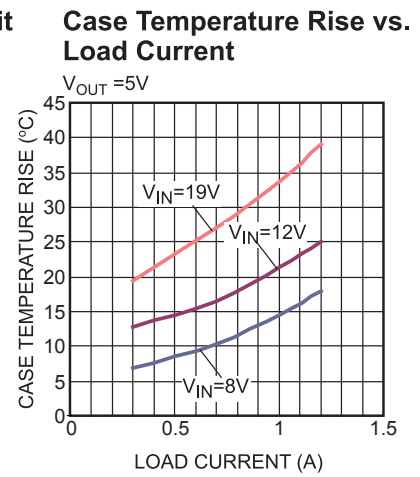
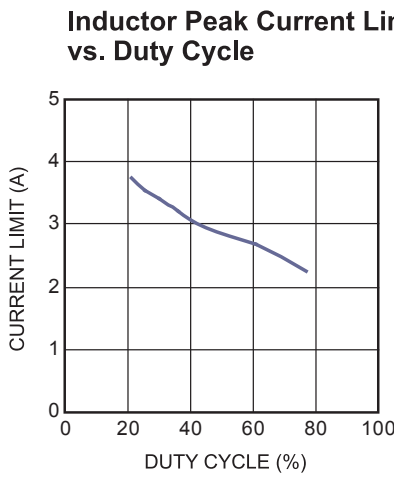
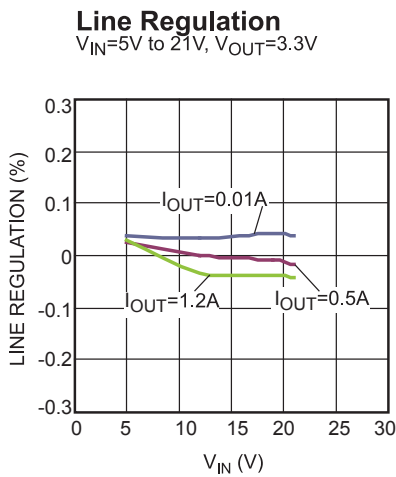
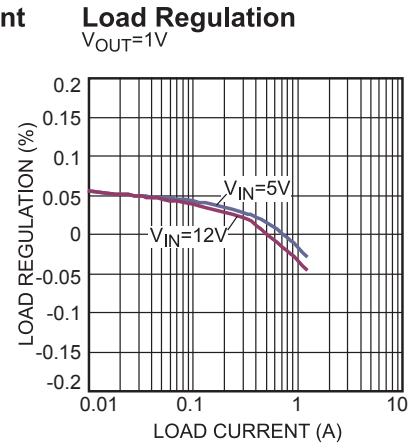
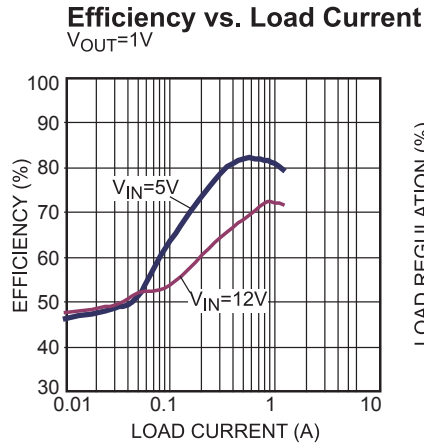
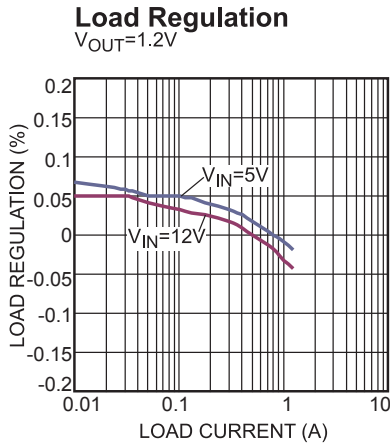


**Efficiency vs. Load Current**  
 $V_{OUT}=1.2V$



**TYPICAL CHARACTERISTICS (continued)**

$V_{IN} = 12V$ ,  $V_{OUT} = 3.3V$ ,  $T_A = 25^\circ C$ , unless otherwise noted.

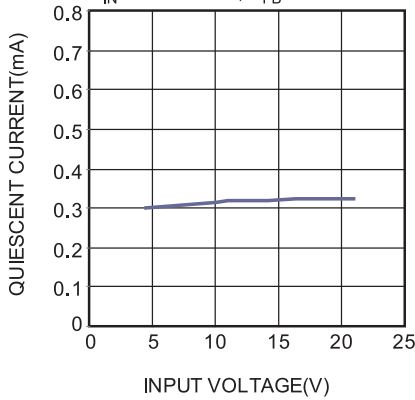


**TYPICAL CHARACTERISTICS (continued)**

$V_{IN} = 12V$ ,  $V_{OUT} = 3.3V$ ,  $T_A = 25^{\circ}C$ , unless otherwise noted.

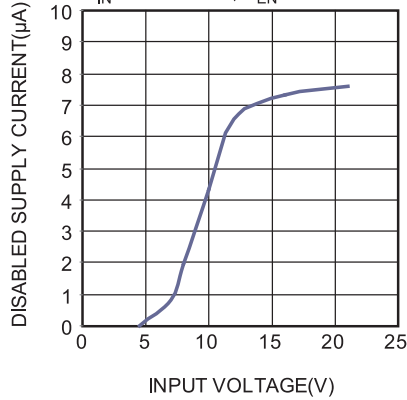
**Quiescent Current vs. Input Voltage**

$V_{IN} = 4.5V$  to  $21V$ ,  $V_{FB} = 1V$



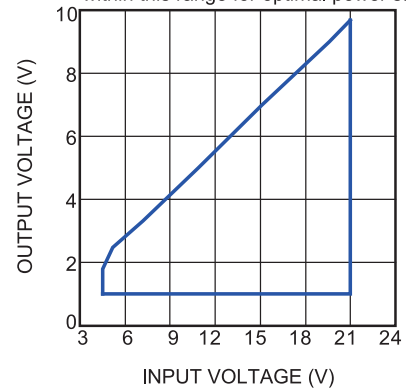
**Disabled Supply Current vs. Input Voltage**

$V_{IN} = 4.5V$  to  $21V$ ,  $V_{EN} = 0V$



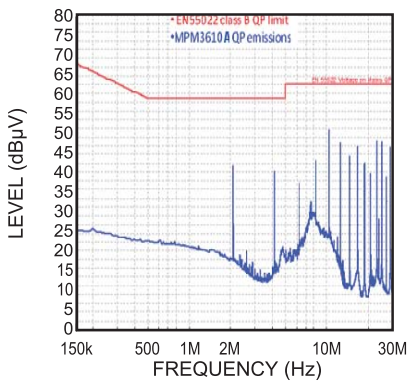
**Power Save Mode Range**

Recommend operating the device within this range for optimal power save mode



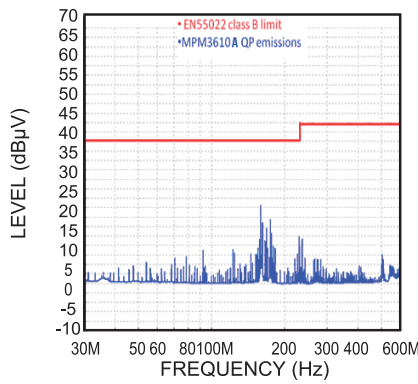
**Conduction-EMI**

$I_{OUT} = 1A$



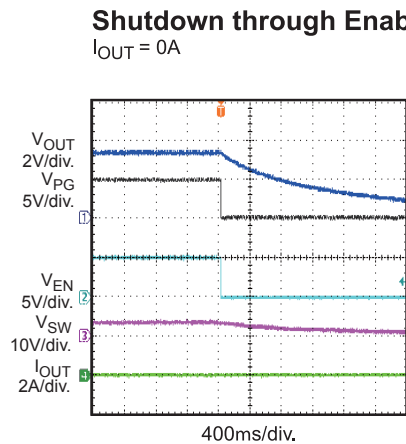
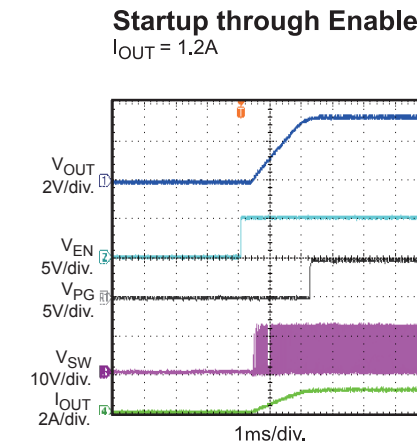
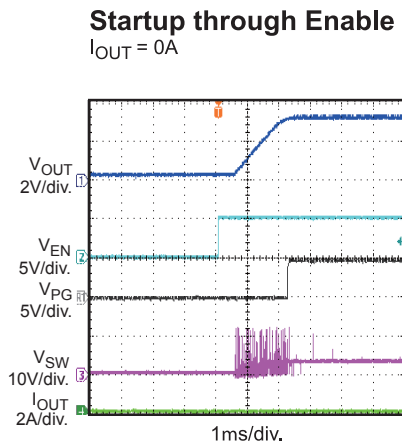
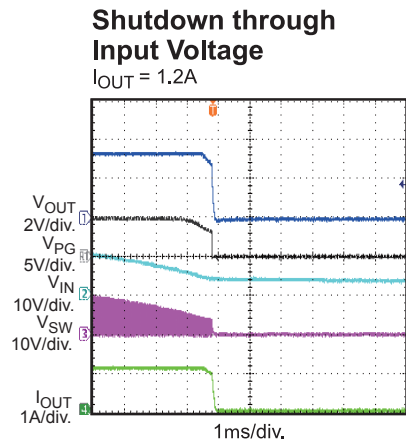
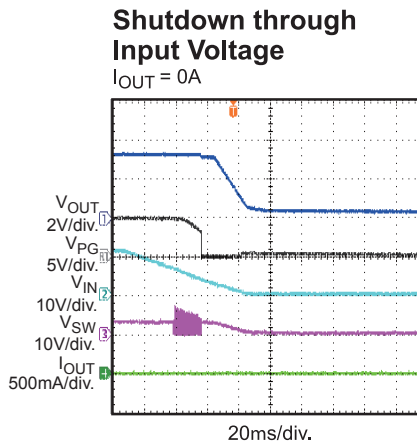
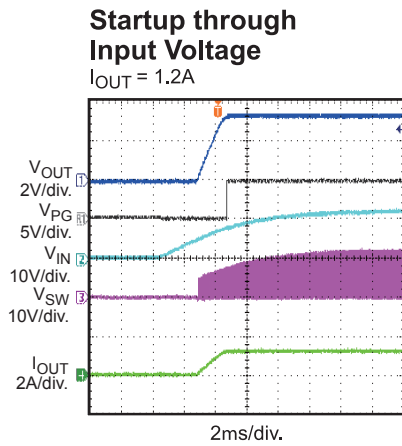
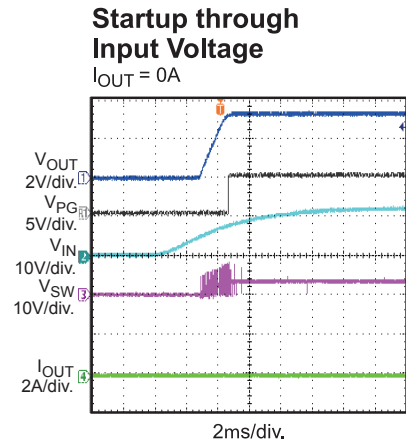
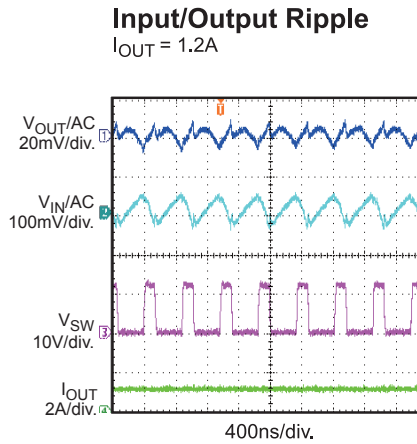
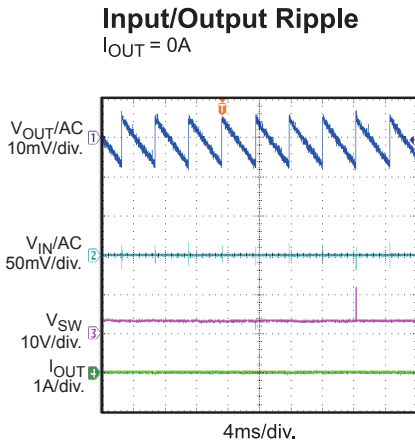
**Radiated-EMI**

$I_{OUT} = 1A$



## TYPICAL PERFORMANCE CHARACTERISTICS

Performance waveforms are captured from the evaluation board discussed in the Design Example section.  $V_{IN} = 12V$ ,  $V_{OUT} = 3.3V$ ,  $T_A = 25^\circ C$ , unless otherwise noted.

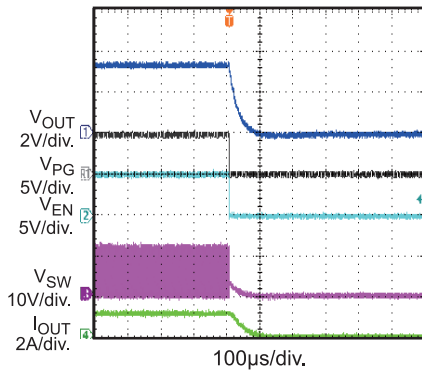


## TYPICAL PERFORMANCE CHARACTERISTICS *(continued)*

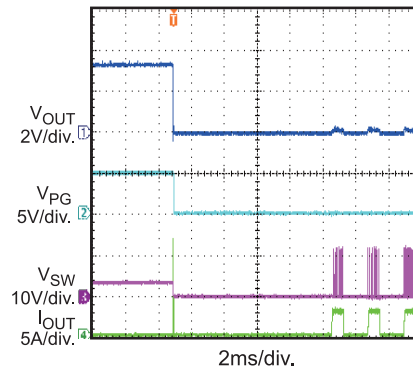
Performance waveforms are captured from the evaluation board discussed in the Design Example section.  $V_{IN} = 12V$ ,  $V_{OUT} = 3.3V$ ,  $T_A = 25^{\circ}C$ , unless otherwise noted.

**Shutdown through Enable**

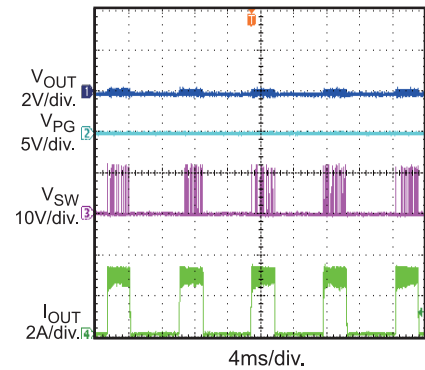
$I_{OUT} = 1.2A$



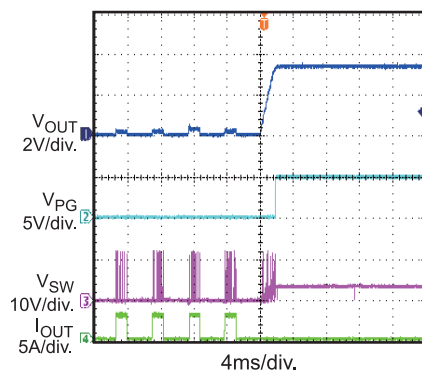
**Short Circuit Entry**



**Short Circuit Steady State**

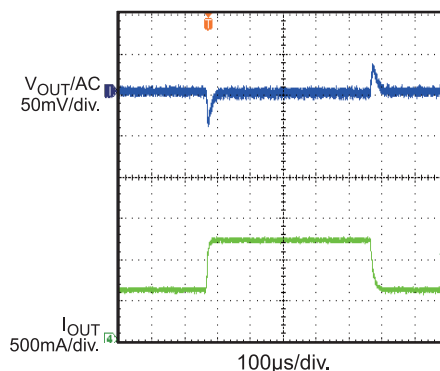


**Short Circuit Recovery**



**Load Transient Response**

0.6A to 1.2A



## PIN FUNCTIONS

Package Pin #	Name	Description
1	FB	Feedback. Connect to the tap of an external resistor divider from the output to AGND to set the output voltage. The frequency fold-back comparator lowers the oscillator frequency when the FB voltage is below 400mV to prevent current limit runaway during a short circuit fault. Place the resistor divider as close to the FB pin as possible. Avoid placing vias on the FB traces.
2	VCC	Internal 5V LDO output. Internal circuit integrates LDO output capacitor, so there is no need to add external capacitor.
3	AGND	Analog Ground. Reference ground of logic circuit. AGND is internally connected to PGND. There is no need to add external connections to PGND.
4, 5, 6	SW	Switch Output. Large copper plane is recommended on pin 4, 5 and 6 for better heat sink.
7, 8, 9	OUT	Power Output. Connect the load to this pin. Output capacitor is needed.
10, 15, 19, 20	NC	DO NOT CONNECT. Pin must be left floating.
11	BST	Bootstrap. Bootstrap capacitor is integrated internally. External connection is not needed.
12, 13, 14	PGND	Power Ground. Reference ground of the power device. PCB layout requires extra care. For best results, connect to PGND with copper and vias.
16	IN	Supply Voltage. The IN pin supplies power to internal MOSFET and regulator. The MPM3610A operates from a +4.5V to +21V input rail. Requires a low-ESR, and low-inductance capacitor to decouple the input rail. Place the input capacitor very close to this pin and connect it with wide PCB traces and multiple vias.
17	EN	Pull the EN pin high to enable the module. Leave it floating or connecting it to GND will disable the module.
18	PG	Power Good Indicator. The PG pin is an open-drain output. Connect PG pin to VCC or other voltage source through a pull up resistor (e.g. 100kΩ). The detail PG behavior is on Power Good Indicator Section in OPERATION.

## FUNCTIONAL BLOCK DIAGRAM

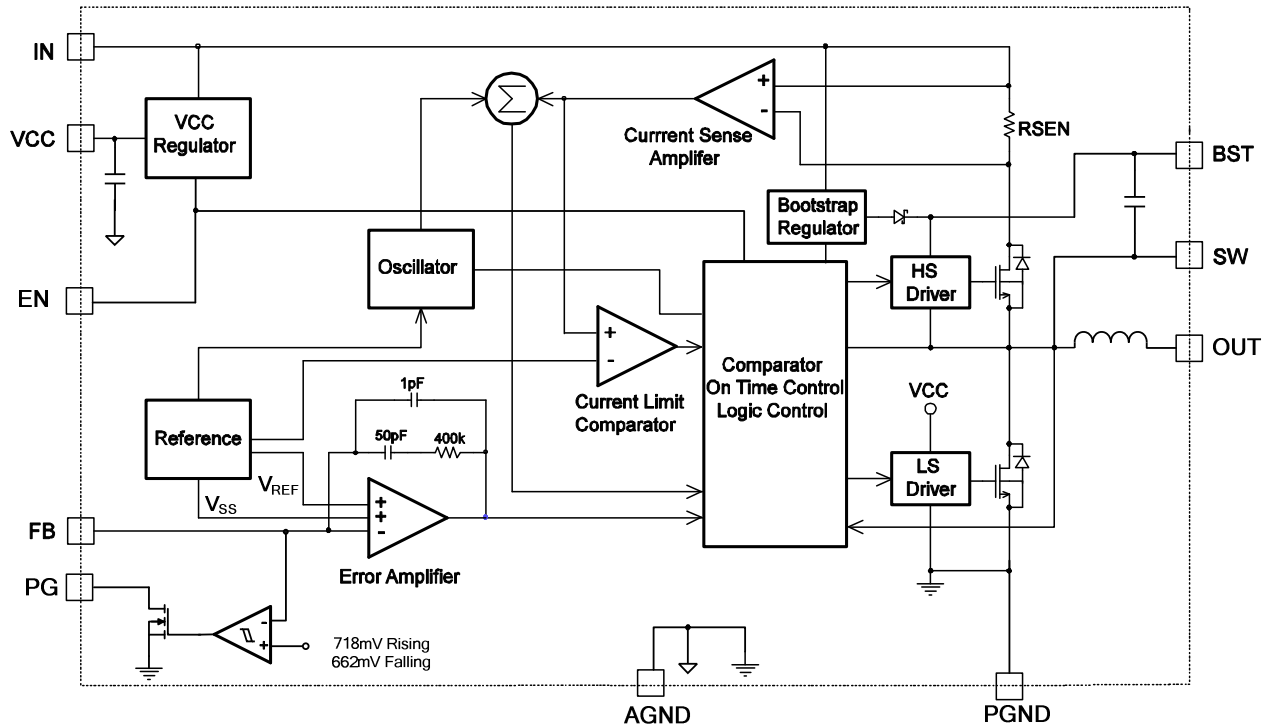


Figure 1: Functional Block Diagram

## OPERATION

The MPM3610A is a high-frequency, synchronous, rectified, step-down, switch-mode converter with built-in power MOSFETs, integrated inductor and two capacitors. It offers a very compact solution that achieves a 1.2A continuous output current with excellent load and line regulation over 4.5V to 21V input supply range.

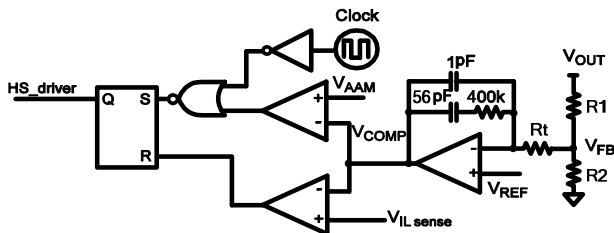
The MPM3610A has three working modes: AAM (Advanced Asynchronous Modulation, similar as PFM) mode, DCM (Discontinuous-Conduction Mode) and CCM (Continuous-Conduction Mode). The device will operate from AAM mode, DCM to CCM with the load current increasing. In some particular condition the device will not enter AAM mode in light load condition, refer to “Power Save Mode Range” curve on page 8.

### AAM Control Operation

In the light load condition, MPM3610A works in AAM mode. Refer to Figure 2, the  $V_{AAM}$  is an internal fixed voltage when input and output voltages are fixed.  $V_{COMP}$  is the error amplifier output which represents the peak inductor current information. When  $V_{COMP}$  is lower than  $V_{AAM}$ , the internal clock is blocked, thus the MPM3610A skips some pulses and achieves the light load power save. Refer to AN032 for more detail.

The internal clock resets every time when  $V_{COMP}$  is higher than  $V_{AAM}$ . At the same time the HS-FET(High-Side MOSFET) turns on and remains on until  $V_{ILsense}$  reaches the value set by  $V_{COMP}$ .

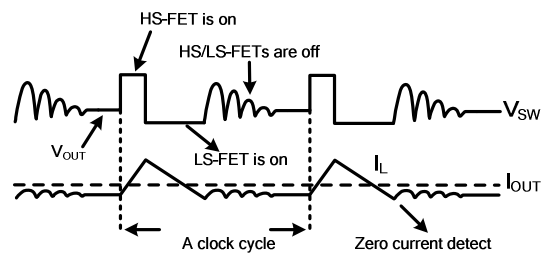
The light load feature in this device is optimized for 12V input applications.



**Figure 2: Simplified AAM Control Logic**

### DCM Control Operation

The  $V_{COMP}$  voltage ramps up with the increasing of the output current, when its minimum value exceeds  $V_{AAM}$ , the device will enter DCM. In this mode the internal 2MHz clock initiates the PWM cycle, the HS-FET turns on and remains on until  $V_{ILsense}$  reaches the value set by  $V_{COMP}$ , after a period of dead time, the LS-FET (Low-Side MOSFET) will turn on and remain on until the inductor current value decreases to zero. The device will repeat the same operation in every clock cycle to regulate the output voltage.



**Figure 3: DCM Control Operation**

### CCM Control Operation

The device will enter CCM from DCM once the inductor current no longer drops to zero in a clock cycle. In CCM the internal 2MHz clock initiates the PWM cycle, the HS-FET turns on and remains on until  $V_{ILsense}$  reaches the value set by  $V_{COMP}$ , after a period of dead time, the LS-FET will turn on and remain on until the next clock cycle starts. The device will repeat the same operation in every clock cycle to regulate the output voltage.

If within 83% of one PWM period,  $V_{ILsense}$  does not reach the value set by  $V_{COMP}$ , the HS power MOSFET is forced off.

### Internal $V_{CC}$ Regulator

A 4.9V internal regulator powers most of the internal circuitries. This regulator takes  $V_{IN}$  and operates in the full  $V_{IN}$  range. When  $V_{IN}$  exceeds 4.9V, the output of the regulator is in full regulation. When  $V_{IN}$  is less than 4.9V, the output decreases, and the part integrates internal decoupling capacitor. No need add external VCC output capacitor.

**Error Amplifier**

The error amplifier compares the FB pin voltage to the internal 0.798V reference ( $V_{REF}$ ) and outputs a current proportional to the difference between the two. This output current then charges or discharges the internal compensation network to form the COMP voltage, which controls the power MOSFET current. The optimized internal compensation network minimizes the external component counts and simplifies the control loop design.

**Under-Voltage Lockout (UVLO)**

Under-voltage lockout (UVLO) protects the chip from operating at insufficient supply voltage. The MPM3610A UVLO comparator monitors the output voltage of the internal regulator, VCC. The UVLO rising threshold is about 3.9V while its falling threshold is 3.225V.

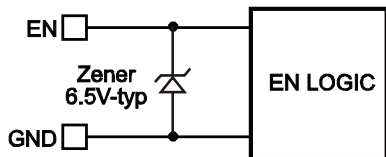
**Enable Control**

EN is a control pin that turns the regulator on and off. Drive EN high to turn on the regulator; drive it low to turn it off. An internal 870kΩ resistor from EN to GND allows EN to be floated to shut down the chip.

The EN pin is clamped internally using a 6.5V series-Zener-diode as shown in Figure 4. Connecting the EN input pin through a pull up resistor to the voltage on the  $V_{IN}$  pin limits the EN input current to less than 100μA.

For example, with 12V connected to  $V_{in}$ ,  $R_{PULLUP} \geq (12V - 6.5V) \div 100\mu A = 55k\Omega$ .

Connecting the EN pin directly to a voltage source without any pull-up resistor requires limiting the amplitude of the voltage source to ≤6V to prevent damage to the Zener diode.



**Figure 4: 6.5V Zener Diode Connection**

**Internal Soft-Start**

The soft-start prevents the converter output voltage from overshooting during startup. When the chip starts, the internal circuitry generates a soft-start voltage (SS) that ramps up from 0V to 5V. When SS is lower than REF, the error

amplifier uses SS as the reference. When SS is higher than REF, the error amplifier uses REF as the reference. The SS time is internally set to 1.6ms( $V_{OUT}$  from 10% to 90%).

**Pre-Bias Startup**

The MPM3610A has been designed for monotonic startup into pre-biased output voltage. If the output is pre-biased to a certain voltage during startup, the voltage on the soft-start capacitor will be charged. When the soft-start capacitor’s voltage exceeds the sensed output voltage at the FB pin, the part starts to turn on high side and low side power switches sequentially. Output voltage starts to ramp up following with soft-start slew rate.

**Power Good Indicator**

The MPM3610A has power good (PG) output used to indicate whether the output voltage of the module is ready or not. The PG pin is an open drain output. Connect PG pin to VCC or other voltage source through a pull up resistor (e.g. 100kΩ). When the input voltage is applied, the PG pin is pulled down to GND before internal  $V_{SS} > 1V$ . After  $V_{SS} > 1V$ , when  $V_{FB}$  is above 90% of  $V_{REF}$ , the PG pin will be pulled high after 35μs delay time. During normal operation, the PG pin will be pulled low when the  $V_{FB}$  drops below 83% of  $V_{REF}$  after 80μs delay.

When UVLO or OTP happens, the PG pin will be pulled low immediately; When OC(Over current) happens, the PG pin will be pulled low when  $V_{FB}$  drops below 83% of  $V_{REF}$  after 80μs delay.

Since MPM3610A doesn’t implement dedicate output over voltage protection, the PG won’t response to output over voltage condition.

**Over-Current-Protection and Hiccup**

The MPM3610A has a cycle-by-cycle over-current limiting control. When the inductor current peak value exceeds internal “peak” current limit threshold, the HS-FET will turn off and the LS-FET will turn on and remains on until the inductor current falls below the internal “valley” current limit threshold. The “valley” current limit circuit is employed to decrease the

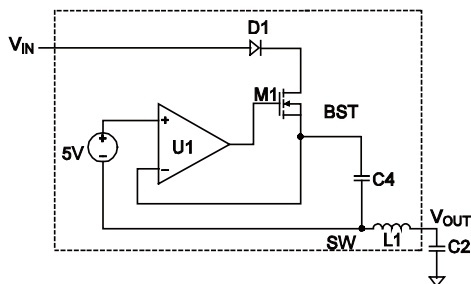
operation frequency after the “peak” current limit threshold is triggered. Meanwhile, the output voltage drops until  $V_{FB}$  is below the Under-Voltage (UV) threshold—typically 50% below the reference. Once UV is triggered, the MPM3610A enters hiccup mode to periodically restart the part. This protection mode is especially useful when the output is dead-shortened to ground, and greatly reduces the average short circuit current to alleviate thermal issues and protect the converter. The MPM3610A exits the hiccup mode once the over-current condition is removed.

**Thermal Shutdown**

Thermal shutdown prevents the chip from operating at exceedingly high temperatures. When the silicon’s temperature exceeds 150°C, the whole chip is shut down. When the temperature drops below its lower threshold, typically 130°C, the chip is enabled again.

**Floating Driver and Bootstrap Charging**

An internal bootstrap capacitor powers the floating power MOSFET driver. This floating driver has its own UVLO protection. This UVLO’s rising threshold is 2.2V with a hysteresis of 150mV. The bootstrap capacitor voltage is regulated internally by  $V_{IN}$  through D1, M1, C4, L1 and C2 (Figure 5). If  $(V_{BST}-V_{SW})$  exceeds 5V, U1 will regulate M1 to maintain a 5V voltage across C4.



**Figure 5: Internal Bootstrap Charging Circuit**

**Startup and Shutdown**

If both  $V_{IN}$  and  $V_{EN}$  exceeds its thresholds, the chip starts. The reference block starts first, generating stable reference voltage, and then the internal regulator is enabled. The regulator provides a stable supply for the remaining circuitries.

Three events can shut down the chip:  $V_{IN}$  low,  $V_{EN}$  low and thermal shutdown. During the

shutdown procedure, the signaling path is first blocked to avoid any fault triggering. The COMP voltage and the internal supply rail are then pulled down. The floating driver is not subject to this shutdown command.

**Additional RC Snubber Circuit**

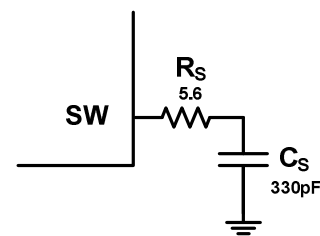
Additional RC snubber circuit can be chosen to damp the device’s spike and ringing voltage to get better EMI performance.

The power dissipation of the RC snubber circuit can be simply estimated by the formula below:

$$P_{Loss} = f_s \times C_s \times V_{IN}^2$$

Where  $f_s$  is the switching frequency;  $C_s$  is the snubber capacitor;  $V_{IN}$  is the input voltage.

For efficiency consideration, the value of  $C_s$  should not be set too large. Commonly a 5.6Ω  $R_s$  and a 330pF  $C_s$  is recommended to generate the RC snubber circuit.



**Figure 6: Additional RC Snubber Circuit**

## APPLICATION INFORMATION

### Setting the Output Voltage

The external resistor divider sets the output voltage (see Typical Application on page 1). Choose R1 refer to Table 1, R2 is then given by:

$$R2 = \frac{R1}{\frac{V_{OUT}}{0.798V} - 1}$$

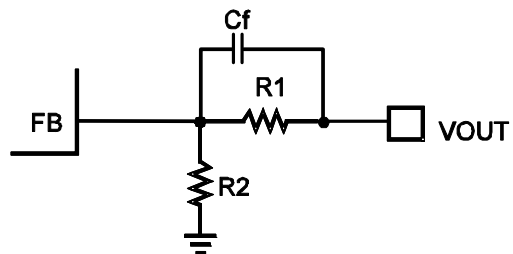


Figure 7: Feedback Network

Table 1 lists the recommended feedback network parameters for common output voltages.

Table 1: Recommended Parameters For Common Output Voltages

V <sub>IN</sub> (V)	V <sub>OUT</sub> (V)	Small Solution Size (C <sub>IN</sub> =10µF/0805/25V, C <sub>OUT</sub> =22µF/0805/16V)					Low V <sub>OUT</sub> Ripple (C <sub>IN</sub> =10µF/0805/25V, C <sub>OUT</sub> =2X22µF/0805/16V)				
		R1 (kΩ)	R2 (kΩ)	C <sub>f</sub> (pF)	V <sub>OUT</sub> Ripple (mV) <sup>(9)</sup>	Load Transient (mV) <sup>(10)</sup>	R1 (kΩ)	R2 (kΩ)	C <sub>f</sub> (pF)	V <sub>OUT</sub> Ripple (mV) <sup>(9)</sup>	Load Transient (mV) <sup>(10)</sup>
21	5	115	22	NS	17.6	119	40.2	7.68	NS	9.4	74
	3.3	102	32.4	NS	12.4	73	62	19.6	NS	7	50
	2.5	102	47.5	5.6	10	48	62	29.4	5.6	5.2	31
19	5	115	22	NS	16.4	116	40.2	7.68	NS	8.8	72
	3.3	102	32.4	NS	11.4	73	62	19.6	NS	6.6	51
	2.5	102	47.5	5.6	9.8	51	62	29.4	5.6	5	33
16	5	115	22	NS	15.6	116	40.2	7.68	NS	7.8	69
	3.3	102	32.4	NS	10.6	72	62	19.6	NS	6	53
	2.5	102	47.5	5.6	9.6	52	62	29.4	5.6	4.8	36
	1.8	102	82	5.6	8.6	41	62	49.9	5.6	4	30
14	5	115	22	NS	14.8	110	40.2	7.68	NS	7.4	65
	3.3	102	32.4	NS	10.2	72	40.2	12.7	NS	5.6	41
	2.5	75	34.8	5.6	9.4	46	40.2	18.7	5.6	4.6	34
	1.8	102	82	5.6	8.4	42	62	49.9	5.6	4.2	31
	1.5	158	180	5.6	7.2	44	62	69.8	5.6	3.6	30
12	5	100	19.1	NS	13.8	93	34	6.49	NS	6.4	56
	3.3	75	24	NS	9.4	61	40.2	12.7	NS	5.2	40
	2.5	75	34.8	5.6	9	51	40.2	18.7	5.6	4.4	34
	1.8	102	82	5.6	7.8	47	47	37.4	5.6	4	29
	1.5	158	180	5.6	6.6	57	47	53.6	5.6	3.4	27
	1.2	158	316	5.6	6.2	51	75	147	5.6	3	32

**Table 1: Recommended Parameters For Common Output Voltages (continued)**

		Small Solution Size( $C_{IN}=10\mu F/0805/25V$ , $C_{OUT}=22\mu F/0805/16V$ )					Low $V_{OUT}$ Ripple( $C_{IN}=10\mu F/0805/25V$ , $C_{OUT}=2X22\mu F/0805/16V$ )				
$V_{IN}$ (V)	$V_{OUT}$ (V)	R1 (k $\Omega$ )	R2 (k $\Omega$ )	$C_f$ (pF)	$V_{OUT}$ Ripple (mV) <sup>(9)</sup>	Load Transient (mV) <sup>(10)</sup>	R1 (k $\Omega$ )	R2 (k $\Omega$ )	$C_f$ (pF)	$V_{OUT}$ Ripple (mV) <sup>(9)</sup>	Load Transient (mV) <sup>(10)</sup>
10	5	100	19.1	NS	13.2	77	34	6.49	NS	6.2	47
	3.3	75	24	NS	8.4	58	40.2	12.7	NS	4.8	40
	2.5	75	34.8	5.6	8.2	51	40.2	18.7	5.6	4	34
	1.8	75	59	5.6	7.2	40	47	37.4	5.6	3.6	30
	1.5	102	115	5.6	6	46	47	53.6	5.6	3.2	28
	1.2	102	205	5.6	5.4	45	62	124	5.6	2.8	32
	1	102	402	5.6	4.8	41	82	324	5.6	2.6	36
8	5	100	19.1	NS	9.2	76	34	6.49	NS	5	48
	3.3	75	24	NS	7.6	57	40.2	12.7	NS	3.8	38
	2.5	75	34.8	5.6	7	48	40.2	18.7	5.6	3.4	33
	1.8	75	59	5.6	6.4	42	47	37.4	5.6	3	32
	1.5	75	84.5	5.6	5.4	44	47	53.6	5.6	2.8	29
	1.2	75	147	5.6	5	38	47	93.1	5.6	2.6	26
	1	75	294	5.6	4.6	35	56	221	5.6	2.2	29
5	3.3	75	24	NS	6	57	40.2	12.7	NS	3.4	40
	2.5	75	34.8	5.6	5.8	52	40.2	18.7	5.6	3.2	32
	1.8	75	59	5.6	5.2	47	47	37.4	5.6	2.8	31
	1.5	62	69.8	5.6	5	41	47	53.6	5.6	2.4	30
	1.2	62	124	5.6	4.6	37	47	93.1	5.6	2.2	29
	1	62	243	5.6	4.4	37	47	187	5.6	2	27

**Notes:**

9) The output voltage ripple is tested at 1.2A output current.

10) Load transient from 0.6A to 1.2A, slew rate =0.8A/ $\mu$ s.

Normally output voltage is recommended to be set from 0.8V to 5.5V. Actually it can be set larger than 5.5V. Output voltage ripple will be larger in this case due to larger inductor ripple current. Additional output capacitor is needed to reduce the output ripple voltage.

When output voltage is high, the chip's heat dissipation become more important, please refer to PC Board layout guidelines on page 18 to achieve better thermal effect.

**Selecting the Input Capacitor**

The input current to the step-down converter is discontinuous, therefore requires a capacitor to supply the AC current to the step-down converter while maintaining the DC input voltage. Use low ESR capacitors for the best performance. Use ceramic capacitors with X5R or X7R dielectrics for best results because of their low ESR and small temperature coefficients. For most applications, use a 10 $\mu$ F capacitor.

Since C1 absorbs the input switching current, it requires an adequate ripple current rating. The RMS current in the input capacitor can be estimated by:

$$I_{C1} = I_{LOAD} \times \sqrt{\frac{V_{OUT}}{V_{IN}} \times \left(1 - \frac{V_{OUT}}{V_{IN}}\right)}$$

For simplification, choose an input capacitor with an RMS current rating greater than half of the maximum load current.

The input capacitor can be electrolytic, tantalum or ceramic. When using electrolytic or tantalum capacitors, add a small, high quality ceramic capacitor (e.g. 0.1µF) placed as close to the IC as possible. When using ceramic capacitors, make sure that they have enough capacitance to provide sufficient charge to prevent excessive voltage ripple at input. The input voltage ripple caused by capacitance can be estimated as:

$$\Delta V_{IN} = \frac{I_{LOAD}}{f_s \times C1} \times \frac{V_{OUT}}{V_{IN}} \times \left(1 - \frac{V_{OUT}}{V_{IN}}\right)$$

### Selecting the Output Capacitor

The output capacitor (C2) maintains the DC output voltage. Use ceramic, tantalum, or low-ESR electrolytic capacitors. For best results, use low ESR capacitors to keep the output voltage ripple low. The output voltage ripple can be estimated as:

$$\Delta V_{OUT} = \frac{V_{OUT}}{f_s \times L_1} \times \left(1 - \frac{V_{OUT}}{V_{IN}}\right) \times \left(R_{ESR} + \frac{1}{8 \times f_s \times C2}\right)$$

Where  $L_1$  is the inductor value and  $R_{ESR}$  is the equivalent series resistance (ESR) value of the output capacitor.  $L_1=1\mu\text{H}$  for MPM3610A.

For ceramic capacitors, the capacitance dominates the impedance at the switching frequency, and the capacitance causes the majority of the output voltage ripple. For simplification, the output voltage ripple can be estimated as:

$$\Delta V_{OUT} = \frac{V_{OUT}}{8 \times f_s^2 \times L_1 \times C2} \times \left(1 - \frac{V_{OUT}}{V_{IN}}\right)$$

For tantalum or electrolytic capacitors, the ESR dominates the impedance at the switching

frequency. For simplification, the output ripple can be approximated as:

$$\Delta V_{OUT} = \frac{V_{OUT}}{f_s \times L_1} \times \left(1 - \frac{V_{OUT}}{V_{IN}}\right) \times R_{ESR}$$

The characteristics of the output capacitor also affect the stability of the regulation system. The MPM3610A internal compensation is optimized for a wide range of capacitance and ESR values.

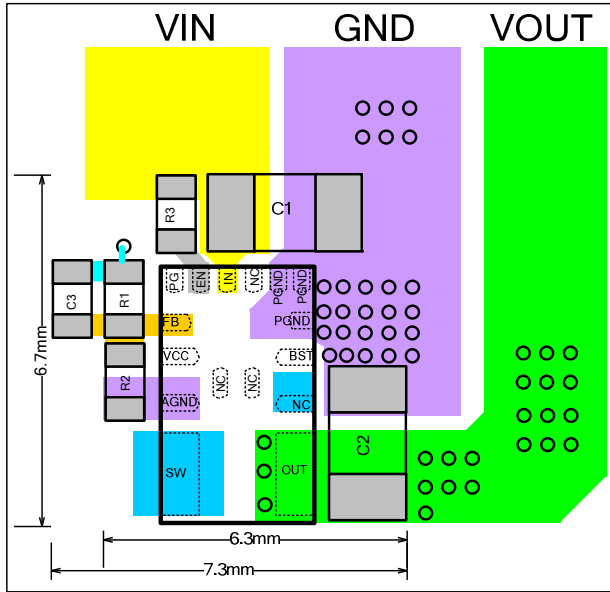
### PC Board Layout <sup>(11)</sup>

PCB layout is very important to achieve stable operation especially for input capacitor placement. For best results, follow these guidelines:

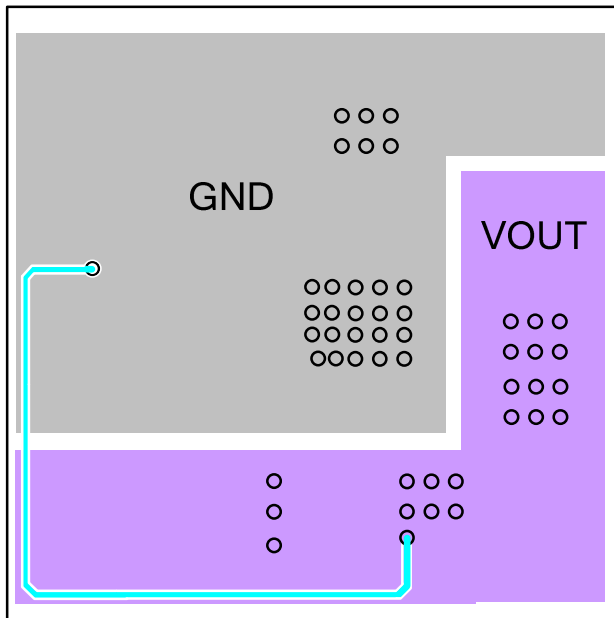
1. Use large ground plane directly connect to PGND pin. Add vias near the PGND pin if bottom layer is ground plane.
2. The high current paths (PGND, IN and OUT) should have short, direct and wide traces. Place the ceramic input capacitor close to IN and PGND pins. Keep the connection of input capacitor and IN pin as short and wide as possible.
3. The external feedback resistors should be placed next to the FB pin.
4. Keep the feedback network away from the switching node.

#### Notes:

- 11) The recommended layout is based on Typical Application Circuits section on page 20.



**Top Layer**



**Bottom Layer**

**Figure 8: Recommend PC Board Layout**

**Design Example**

Below is a design example following the application guidelines for the specifications:

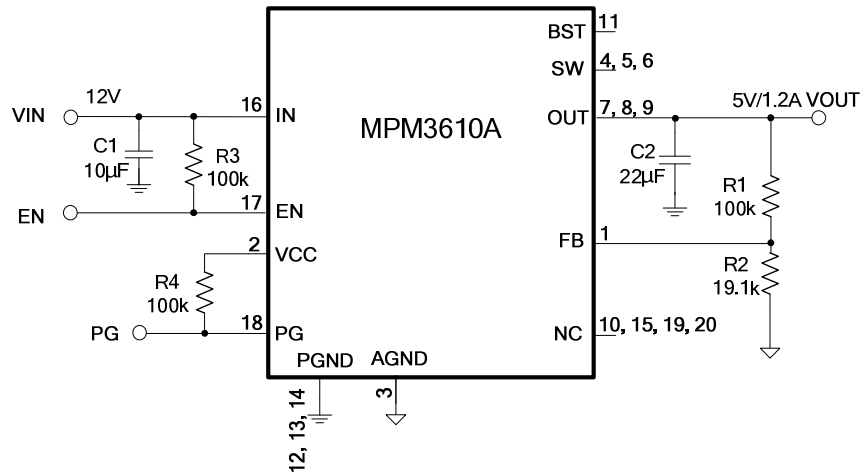
**Table 2: Design Example**

$V_{IN}$	12V
$V_{OUT}$	3.3V
$I_{OUT}$	1.2A

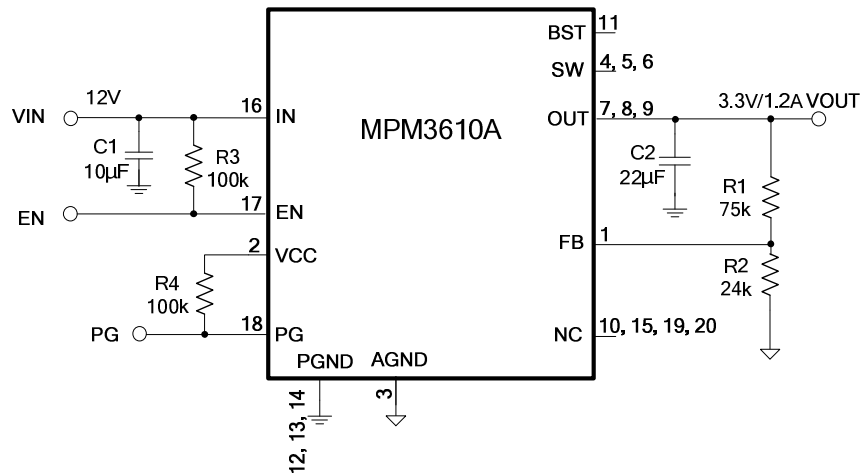
The detailed application schematic is shown in

Figure 10. The typical performance and circuit waveforms have been shown in the Typical Performance Characteristics section. For more device applications, please refer to the related Evaluation Board Datasheets.

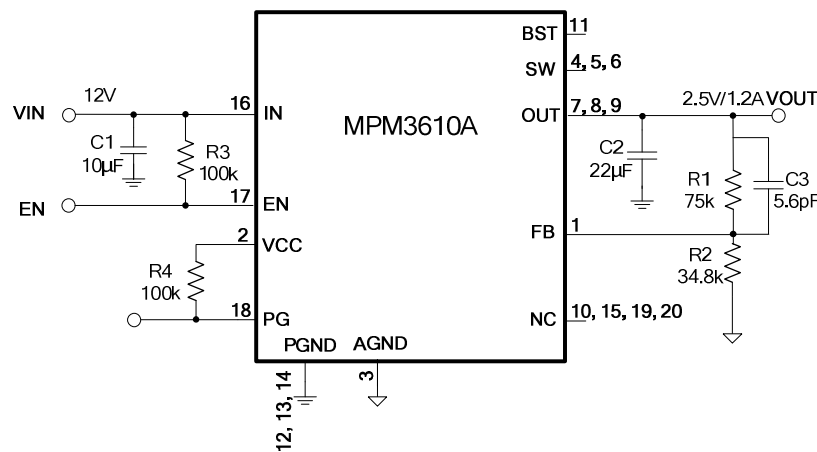
**TYPICAL APPLICATION CIRCUITS<sup>(12)</sup>**



**Figure 9: Vo=5V, Io=1.2A**

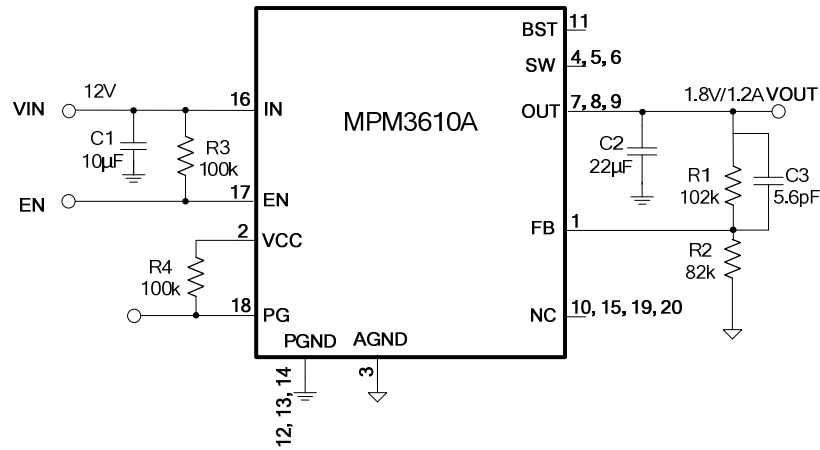


**Figure 10: Vo=3.3V, Io=1.2A**

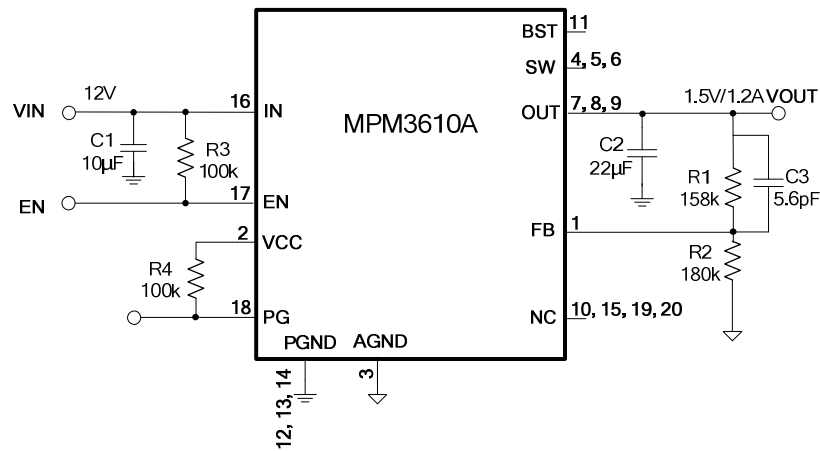


**Figure 11: Vo=2.5V, Io=1.2A**

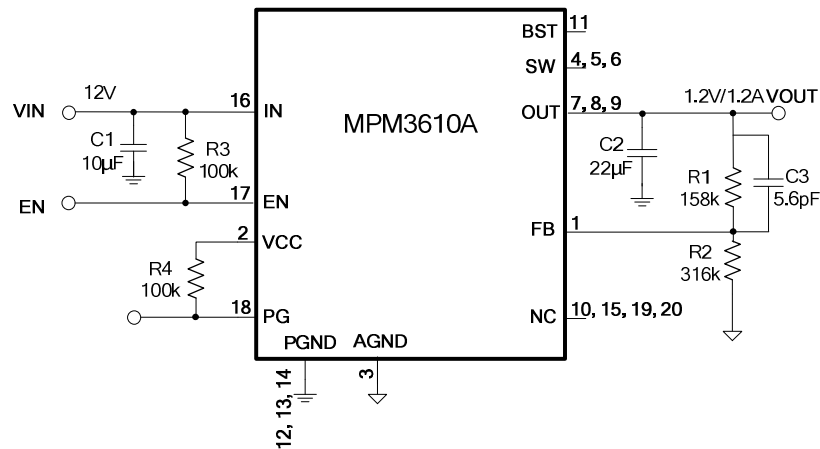
**TYPICAL APPLICATION CIRCUITS**(continued)



**Figure 12:  $V_o=1.8V$ ,  $I_o=1.2A$**

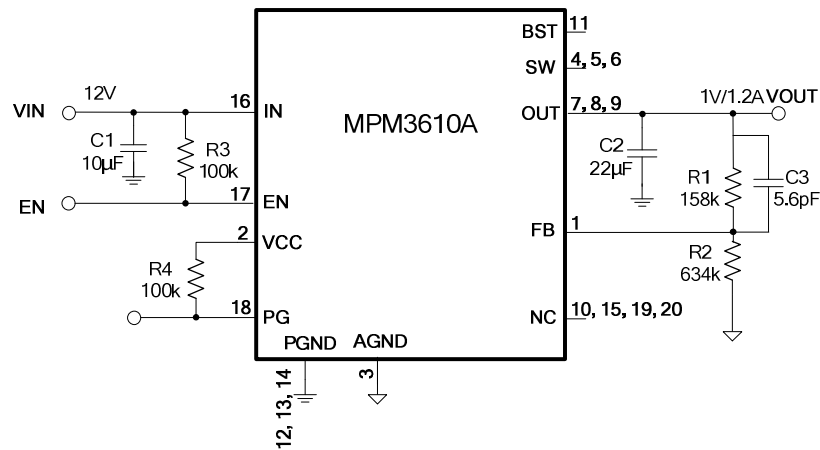


**Figure 13:  $V_o=1.5V$ ,  $I_o=1.2A$**



**Figure 14:  $V_o=1.2V$ ,  $I_o=1.2A$**

**TYPICAL APPLICATION CIRCUITS** *(continued)*



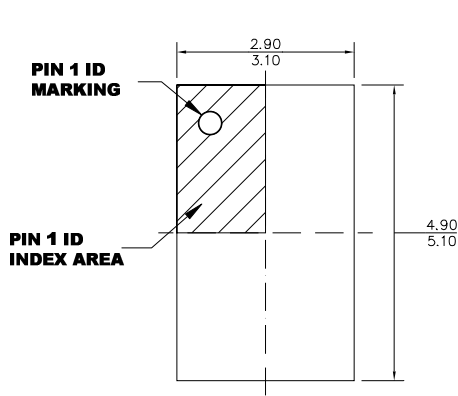
**Figure 15:  $V_o=1V$ ,  $I_o=1.2A$**

**Notes:**

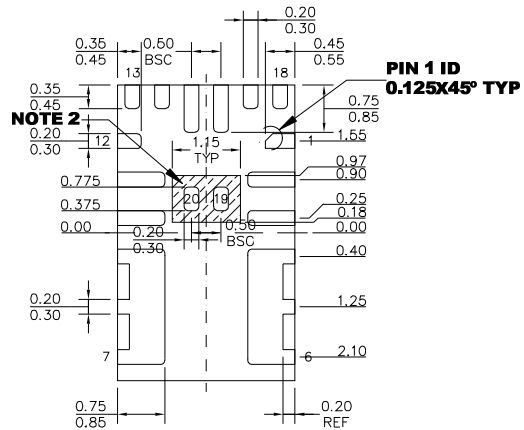
- 12) In  $12V_{IN}$  to  $1V_{OUT}$  application condition, the HS-FET's on time is close to minimum on time, the SW may have a little jitter, even so the output voltage ripple is smaller than 15mV.

**PACKAGE INFORMATION**

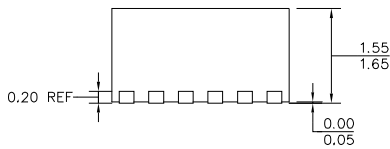
**QFN-20 (3mmx5mmx1.6mm)**



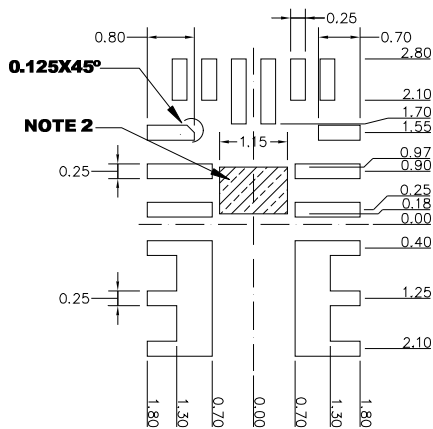
**TOP VIEW**



**BOTTOM VIEW**



**SIDE VIEW**



**RECOMMENDED LAND PATTERN**

**NOTE:**

- 1) ALL DIMENSIONS ARE IN MILLIMETERS.
- 2) SHADED AREA IS THE KEEP-OUT ZONE. ANY PCB METAL TRACE AND VIA ARE NOT ALLOWED TO CONNECT TO THIS AREA ELECTRICALLY OR MECHANICALLY.
- 3) EXPOSED PADDLE SIZE DOES NOT INCLUDE MOLD FLASH.
- 4) LEAD COPLANARITY SHALL BE 0.10 MILLIMETERS MAX.
- 5) JEDEC REFERENCE IS MO-220.
- 6) DRAWING IS NOT TO SCALE.

**NOTICE:** The information in this document is subject to change without notice. Users should warrant and guarantee that third party Intellectual Property rights are not infringed upon when integrating MPS products into any application. MPS will not assume any legal responsibility for any said applications.