

# 8-Channel PMBus Power System Manager Featuring Accurate Output Voltage Measurement

## FEATURES

- Sequence, Trim, Margin and Supervise Eight Power Supplies
- Manage Faults, Monitor Telemetry and Create Fault Logs
- PMBus™ Compliant Command Set
- Supported by LTpowerPlay® GUI
- Margin or Trim Supplies to Within 0.25% of Target
- Fast OV/UV Supervisors Per Channel
- Coordinate Sequencing and Fault Management Across Multiple LTC PSM Devices
- Automatic Fault Logging to Internal EEPROM
- Operate Autonomously without Additional Software
- Internal Temperature and Input Voltage Supervisors
- Accurate Monitoring of Eight Output Voltages, Input Voltage and Internal Die Temperature
- I<sup>2</sup>C/SMBus Serial Interface
- Can Be Powered from 3.3V, or 4.5V to 15V
- Programmable Watchdog Timer
- 100% Pin-Compatible Upgrade to the LTC2978/LTC2978A
- Available in 64-Pin 9mm × 9mm QFN Package
- AEC-Q100 Qualified for Automotive Applications

## APPLICATIONS

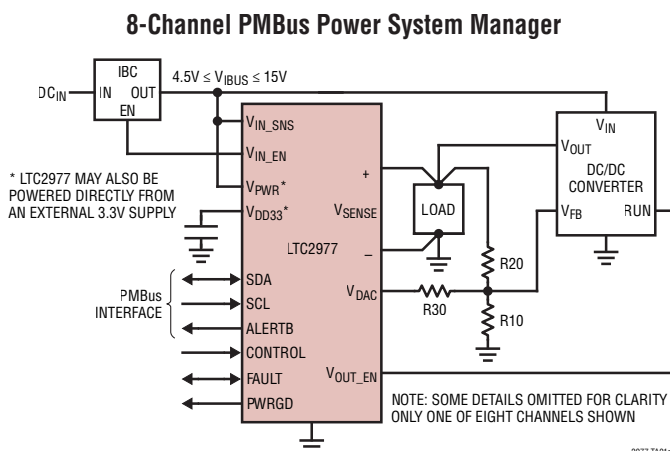
- Computers and Network Servers
- Industrial Test and Measurement
- High Reliability Systems
- Medical Imaging
- Video

## DESCRIPTION

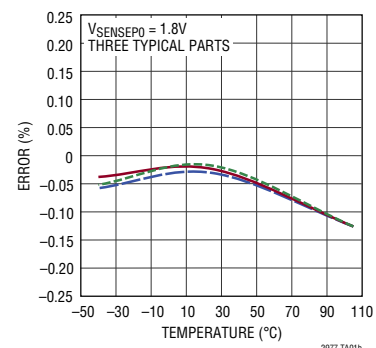
The LTC<sup>®</sup>2977 is an 8-channel Power System Manager used to sequence, trim (servo), margin, supervise, manage faults, provide telemetry and create fault logs. PMBus commands support power supply sequencing, precision point-of-load voltage adjustment and margining. DACs use a proprietary soft-connect algorithm to minimize supply disturbances. Supervisory functions include overvoltage and undervoltage threshold limits for eight power supply output channels and one power supply input channel, as well as over and under temperature limits. Programmable fault responses can disable the power supplies with optional retry after a fault is detected. Faults that disable a power supply can automatically trigger black box EEPROM storage of fault status and associated telemetry. An internal 16-bit ADC monitors eight output voltages, one input voltage, and die temperature. In addition, odd numbered channels can be configured to measure the voltage across a current sense resistor. A programmable watchdog timer monitors microprocessor activity for a stalled condition and resets the microprocessor if necessary. A single wire bus synchronizes power supplies across multiple LTC Power System Management (PSM) devices. Configuration EEPROM with ECC supports autonomous operation without additional software.

All registered trademarks and trademarks are the property of their respective owners. Protected by U.S. Patents including 7382303, 7420359 and 7940091.

## TYPICAL APPLICATION



**Typical ADC Total Unadjusted Error vs Temperature**



## TABLE OF CONTENTS

<b>Features</b> .....	1	Output Voltage Related Commands .....	36
<b>Applications</b> .....	1	VOUT_COMMAND, VOUT_MAX, VOUT_MARGIN_	
<b>Typical Application</b> .....	1	HIGH, VOUT_MARGIN_LOW, VOUT_OV_FAULT_LIMIT,	
<b>Description</b> .....	1	VOUT_OV_WARN_LIMIT, VOUT_UV_WARN_LIMIT,	
<b>Absolute Maximum Ratings</b> .....	4	VOUT_UV_FAULT_LIMIT, POWER_GOOD_ON and	
<b>Order Information</b> .....	4	POWER_GOOD_OFF.....	36
<b>Pin Configuration</b> .....	4	Input Voltage Related Commands.....	36
<b>Electrical Characteristics</b> .....	5	VIN_ON, VIN_OFF, VIN_OV_FAULT_LIMIT,	
<b>PMBus Timing Diagram</b> .....	9	VIN_OV_WARN_LIMIT, VIN_UV_WARN_LIMIT and	
<b>Typical Performance Characteristics</b> .....	10	VIN_UV_FAULT_LIMIT .....	36
<b>Pin Functions</b> .....	13	Temperature Related Commands .....	37
<b>Block Diagram</b> .....	15	OT_FAULT_LIMIT, OT_WARN_LIMIT,	
<b>Operation</b> .....	16	UT_WARN_LIMIT and UT_FAULT_LIMIT.....	37
Operation Overview.....	16	Timer Limits.....	37
EEPROM .....	17	TON_DELAY, TON_RISE, TON_MAX_FAULT_LIMIT	
Reset.....	17	and TOFF_DELAY.....	37
Other Operations.....	17	Fault Response for Voltages Measured by the High Speed	
Clock Sharing .....	17	Supervisor.....	38
PMBus Serial Digital Interface .....	18	VOUT_OV_FAULT_RESPONSE and VOUT_UV_FAULT_	
PMBus.....	18	RESPONSE .....	38
Device Address.....	21	Fault Response for Values Measured by the ADC.....	39
Processing Commands.....	22	OT_FAULT_RESPONSE, UT_FAULT_RESPONSE, VIN_	
<b>PMBus Command Summary</b> .....	23	OV_FAULT_RESPONSE and	
Summary Table.....	23	VIN_UV_FAULT_RESPONSE.....	39
Data Formats.....	27	Timed Fault Response.....	40
<b>PMBus Command Description</b> .....	28	TON_MAX_FAULT_RESPONSE.....	40
Addressing and Write Protect.....	28	Status Commands.....	41
PAGE.....	28	STATUS_BYTE.....	41
WRITE_PROTECT.....	28	STATUS_WORD.....	41
WRITE PROTECT Pin.....	29	STATUS_VOUT .....	42
MFR_PAGE_FF_MASK .....	29	STATUS_INPUT .....	42
MFR_I2C_BASE_ADDRESS.....	30	STATUS_TEMPERATURE.....	42
MFR_COMMAND_PLUS, MFR_DATA_PLUS0,		STATUS_CML .....	43
MFR_DATA_PLUS1, MFR_STATUS_PLUS0, and MFR_		STATUS_MFR_SPECIFIC.....	43
STATUS_PLUS1 .....	30	ADC Monitoring Commands .....	44
Reading Fault Log Using Command Plus and Mfr_		READ_VIN .....	44
data_plus0.....	31	READ_VOUT .....	44
Peek Operation using Mfr_data_plus0 .....	32	READ_TEMPERATURE_1 .....	44
Enabling and Disabling Poke Operations .....	32	PMBUS_REVISION .....	44
Poke Operation Using Mfr_data_plus0 .....	32	Manufacturer Specific Commands.....	45
Command Plus Operations Using		MFR_CONFIG_LTC2977 .....	45
Mfr_data_plus1 .....	32	Tracking Supplies On and Off .....	46
Operation, Mode and EEPROM Commands .....	33	Tracking Implementation.....	48
OPERATION .....	33	MFR_CONFIG_ALL_LTC2977 .....	49
ON_OFF_CONFIG.....	34	MFR_FAULTBz0_PROPAGATE,	
CLEAR_FAULTS.....	34	MFR_FAULTBz1_PROPAGATE.....	50
STORE_USER_ALL and RESTORE_USER_ALL.....	35	MFR_PWRGD_EN .....	51
CAPABILITY.....	35		
VOUT_MODE .....	35		

## TABLE OF CONTENTS

MFR_FAULTB00_RESPONSE, MFR_FAULTB01_RESPONSE, MFR_FAULTB10_RESPONSE and MFR_FAULTB11_RESPONSE .....	52	On State Operation .....	75
MFR_VINEN_OV_FAULT_RESPONSE .....	53	Servo Modes .....	75
MFR_VINEN_UV_FAULT_RESPONSE .....	54	DAC Modes .....	75
MFR_RETRY_COUNT .....	55	Margining .....	76
MFR_RETRY_DELAY .....	55	Off Sequencing .....	76
MFR_RESTART_DELAY .....	55	V <sub>OUT</sub> Off Threshold Voltage .....	76
MFR_VOUT_PEAK .....	56	Automatic Restart Via MFR_RESTART_DELAY Command and CONTROLn Pin .....	76
MFR_VIN_PEAK .....	56	Fault Management .....	76
MFR_TEMPERATURE_PEAK .....	56	Output Overvoltage and Undervoltage Faults .....	76
MFR_DAC .....	56	Output Overvoltage and Undervoltage Warnings .....	77
MFR_POWERGOOD_ASSERTION_DELAY .....	57	Configuring the V <sub>IN_EN</sub> Output .....	77
MFR_PADS .....	57	Multichannel Fault Management .....	79
MFR_SPECIAL_ID .....	58	Interconnect Between Multiple LTC2977's .....	79
MFR_SPECIAL_LOT .....	58	Application Circuits .....	80
MFR_INFO .....	58	Trimming and Margining DC/DC Converters with External Feedback Resistors .....	80
MFR_VOUT_DISCHARGE_THRESHOLD .....	59	Four-Step Resistor Selection Procedure for DC/DC Converters with External Feedback Resistors .....	81
MFR_COMMON .....	59	Trimming and Margining DC/DC Converters with a TRIM Pin .....	82
USER_DATA_00, USER_DATA_01, USER_DATA_02, USER_DATA_03, USER_DATA_04, MFR_LTC_RESERVED_1 and MFR_LTC_RESERVED_2 .....	60	Two-Step Resistor and DAC Full-Scale Voltage Selection Procedure for DC/DC Converters with a TRIM Pin .....	82
MFR_VOUT_MIN .....	60	Measuring Current .....	82
MFR_VIN_MIN .....	60	Measuring Current with a Sense Resistor .....	83
MFR_TEMPERATURE_MIN .....	61	Measuring Current with Inductor DCR .....	83
MFR_STATUS_2 .....	61	Single Phase Design Example .....	83
MFR_TELEMETRY .....	62	Measuring Multiphase Currents .....	83
Watchdog Operation .....	63	Multiphase Design Example .....	84
MFR_WATCHDOG_T_FIRST and MFR_WATCHDOG_T .....	63	Anti-aliasing Filter Considerations .....	84
Bulk Programming the User EEPROM Space .....	63	Sensing Negative Voltages .....	85
MFR_EE_UNLOCK .....	64	Connecting the DC1613 USB to I <sup>2</sup> C/SMBus/PMBus Controller to the LTC2977 in System .....	85
MFR_EE_ERASE .....	64	Design Checklist .....	87
MFR_EE_DATA .....	64	Logic Signals .....	87
Response When Part Is Busy .....	65	DAC Outputs .....	87
MFR_EE Erase and Write Programming Time .....	65	LTpowerPlay: An Interactive GUI for Power System Managers .....	87
Fault Log Operation .....	65	PCB Assembly and Layout Suggestions .....	88
MFR_FAULT_LOG_STORE .....	65	Bypass Capacitor Placement .....	88
MFR_FAULT_LOG_RESTORE .....	65	Exposed Pad Stencil Design .....	88
MFR_FAULT_LOG_CLEAR .....	66	PC Board Layout .....	89
MFR_FAULT_LOG_STATUS .....	66	Unused ADC Sense Inputs .....	89
MFR_FAULT_LOG .....	67	<b>Package Description</b> .....	<b>90</b>
<b>Applications Information</b> .....	<b>74</b>	<b>Revision History</b> .....	<b>91</b>
Overview .....	74	<b>Typical Application</b> .....	<b>92</b>
Powering the LTC2977 .....	74	<b>Related Parts</b> .....	<b>92</b>
Setting Command Register Values .....	74		
Sequence, Servo, Margin and Restart Operations .....	74		
Command Units On or Off .....	74		
On Sequencing .....	75		

## ABSOLUTE MAXIMUM RATINGS

(Notes 1, 2)

Supply Voltages:

$V_{PWR}$ .....	-0.3V to 15V
$V_{DD33}$ .....	-0.3V to 3.6V
$V_{DD25}$ .....	-0.3V to 2.75V

Digital Input/Output Voltages:

ALERTB, SDA, SCL, CONTROL0, CONTROL1.....	-0.3V to 5.5V
PWRGD, SHARE_CLK, WDI/RESETB, WP.....	-0.3V to $V_{DD33} + 0.3V$
FAULTB00, FAULTB01, FAULTB10, FAULTB11.....	-0.3V to $V_{DD33} + 0.3V$
ASEL0, ASEL1.....	-0.3V to $V_{DD33} + 0.3V$

Analog Voltages:

REFP.....	-0.3V to 1.35V
REFM.....	-0.3V to 0.3V
$V_{IN\_SNS}$ .....	-0.3V to 15V
$V_{SENSE[7:0]}$ .....	-0.3V to 6V
$V_{OUT\_EN[3:0]}$ , $V_{IN\_EN}$ .....	-0.3V to 15V
$V_{OUT\_EN[7:4]}$ .....	-0.3V to 6V
$V_{DACP[7:0]}$ .....	-0.3V to 6V
$V_{DACM[7:0]}$ .....	-0.3V to 0.3V

Operating Junction Temperature Range:

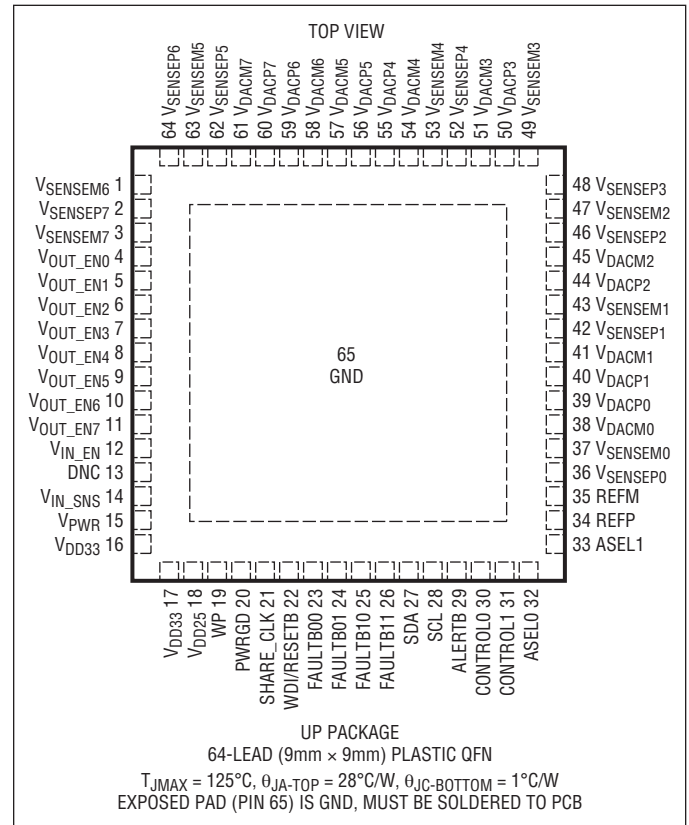
LTC2977C.....	0°C to 70°C
LTC2977I.....	-40°C to 105°C

Storage Temperature Range ..... -65°C to 150°C\*

Maximum Junction Temperature ..... 125°C\*

\*See Operation section for detailed EEPROM de-rating information for junction temperatures in excess of 105°C.

## PIN CONFIGURATION



## ORDER INFORMATION

LEAD FREE FINISH	TAPE AND REEL	PART MARKING*	PACKAGE DESCRIPTION	JUNCTION TEMPERATURE RANGE
LTC2977CUP#PBF	LTC2977CUP#TRPBF	LTC2977UP	64-Pin (9mm × 9mm) Plastic QFN	0°C to 70°C
LTC2977IUP#PBF	LTC2977IUP#TRPBF	LTC2977UP	64-Pin (9mm × 9mm) Plastic QFN	-40°C to 105°C

### AUTOMOTIVE PRODUCTS\*\*

LTC2977IUP#WPBF	LTC2977IUP#WTRPBF	LTC2977UP	64-Pin (9mm × 9mm) Plastic QFN	-40°C to 105°C
-----------------	-------------------	-----------	--------------------------------	----------------

Contact the factory for parts specified with wider operating temperature ranges. \*The temperature grade is identified by a label on the shipping container.

**Tape and reel specifications.** Some packages are available in 500 unit reels through designated sales channels with #TRMPBF suffix.

\*\*Versions of this part are available with controlled manufacturing to support the quality and reliability requirements of automotive applications. These models are designated with a #W suffix. Only the automotive grade products shown are available for use in automotive applications. Contact your local Analog Devices account representative for specific product ordering information and to obtain the specific Automotive Reliability reports for these models.

**ELECTRICAL CHARACTERISTICS** The ● denotes the specifications which apply over the full operating temperature range, otherwise specifications are at  $T_J = 25^\circ\text{C}$ .  $V_{PWR} = V_{IN\_SNS} = 12\text{V}$ ,  $V_{DD33}$ ,  $V_{DD25}$ , REFP and REFM pins floating, unless otherwise indicated.  $C_{VDD33} = 100\text{nF}$ ,  $C_{VDD25} = 100\text{nF}$  and  $C_{REF} = 100\text{nF}$ . (Note 2)

SYMBOL	PARAMETER	CONDITIONS	MIN	TYP	MAX	UNITS	
<b>Power Supply Characteristics</b>							
$V_{PWR}$	$V_{PWR}$ Supply Input Operating Range		● 4.5		15	V	
$I_{PWR}$	$V_{PWR}$ Supply Current	$4.5\text{V} \leq V_{PWR} \leq 15\text{V}$ , $V_{DD33}$ Floating	●	10	13	mA	
$I_{VDD33}$	$V_{DD33}$ Supply Current	$3.13\text{V} \leq V_{DD33} \leq 3.47\text{V}$ , $V_{PWR} = V_{DD33}$	●	10	13	mA	
$V_{UVLO\_VDD33}$	$V_{DD33}$ Undervoltage Lockout	$V_{DD33}$ Ramping Up, $V_{PWR} = V_{DD33}$	●	2.35	2.55	2.8	V
	$V_{DD33}$ Undervoltage Lockout Hysteresis			120		mV	
$V_{DD33}$	Supply Input Operating Range	$V_{PWR} = V_{DD33}$	●	3.13		3.47	V
	Regulator Output Voltage	$4.5\text{V} \leq V_{PWR} \leq 15\text{V}$	●	3.13	3.26	3.47	V
	Regulator Output Short-Circuit Current	$V_{PWR} = 4.5\text{V}$ , $V_{DD33} = 0\text{V}$	●	75	90	140	mA
$V_{DD25}$	Regulator Output Voltage	$3.13\text{V} \leq V_{DD33} \leq 3.47\text{V}$	●	2.35	2.5	2.6	V
	Regulator Output Short-Circuit Current	$V_{PWR} = V_{DD33} = 3.47\text{V}$ , $V_{DD25} = 0\text{V}$	●	30	55	80	mA
$t_{INIT}$	Initialization Time	Time from $V_{IN}$ Applied Until the $TON\_DELAY$ Timer Starts		42		ms	
<b>Voltage Reference Characteristics</b>							
$V_{REF}$	Output Voltage (Note 3)	$V_{REF} = V_{REFP} - V_{REFM}$ , $0 < I_{REFP} < 100\mu\text{A}$		1.232		V	
	Temperature Coefficient			3		ppm/ $^\circ\text{C}$	
	Hysteresis	(Note 4)		100		ppm	
<b>ADC Characteristics</b>							
$V_{IN\_ADC}$	Voltage Sense Input Range	Differential Voltage: $V_{IN\_ADC} = (V_{SENSEPN} - V_{SENSEMN})$	●	0	6	V	
		Single-Ended Voltage: $V_{SENSEMN}$	●	-0.1	0.1	V	
	Current Sense Input Range (Odd Numbered Channels Only)	Single-Ended Voltage: $V_{SENSEPN}$ , $V_{SENSEMN}$	●	-0.1	6	V	
		Differential Voltage: $V_{IN\_ADC}$	●	-170	170	mV	
$N\_ADC$	Voltage Sense Resolution Uses L16 Format	$0\text{V} \leq V_{IN\_ADC} \leq 6\text{V}$ $Mfr\_config\_adc\_hires = 0$		122		$\mu\text{V}/\text{LSB}$	
	Current Sense Resolution (Odd Numbered Channels Only)	$0\text{mV} \leq  V_{IN\_ADC}  < 16\text{mV}$ (Note 12) $16\text{mV} \leq  V_{IN\_ADC}  < 32\text{mV}$ $32\text{mV} \leq  V_{IN\_ADC}  < 63.9\text{mV}$ $63.9\text{mV} \leq  V_{IN\_ADC}  < 127.9\text{mV}$ $127.9\text{mV} \leq  V_{IN\_ADC} $ $Mfr\_config\_adc\_hires = 1$		15.625 31.25 62.5 125 250		$\mu\text{V}/\text{LSB}$ $\mu\text{V}/\text{LSB}$ $\mu\text{V}/\text{LSB}$ $\mu\text{V}/\text{LSB}$ $\mu\text{V}/\text{LSB}$	
$TUE\_ADC\_VOLT\_SNS$	Total Unadjusted Error (Note 3)	Voltage Sense Mode $V_{IN\_ADC} \geq 1\text{V}$	●		$\pm 0.25$	% of Reading	
		Voltage Sense Mode $0 \leq V_{IN\_ADC} \leq 1\text{V}$	●		$\pm 2.5$	mV	
$TUE\_ADC\_CURR\_SNS$	Total Unadjusted Error (Note 3)	Current Sense Mode, Odd Numbered Channels Only, $20\text{mV} \leq V_{IN\_ADC} \leq 170\text{mV}$	●		$\pm 0.7$	% of Reading	
		Current Sense Mode, Odd Numbered Channels Only, $V_{IN\_ADC} \leq 20\text{mV}$	●		$\pm 140$	$\mu\text{V}$	
$V_{OS\_ADC}$	Offset Error	Current Sense Mode, Odd Numbered Channels Only	●		$\pm 100$	$\mu\text{V}$	
$t_{CONV\_ADC}$	Conversion Time	Voltage Sense Mode (Note 5)		6.15		ms	
		Current Sense Mode (Note 5)		24.6		ms	
		Temperature Input (Note 5)		24.6		ms	

**ELECTRICAL CHARACTERISTICS** The ● denotes the specifications which apply over the full operating temperature range, otherwise specifications are at  $T_J = 25^\circ\text{C}$ .  $V_{PWR} = V_{IN\_SNS} = 12\text{V}$ ;  $V_{DD33}$ ,  $V_{DD25}$ , REFP and REFM pins floating, unless otherwise indicated.  $C_{VDD33} = 100\text{nF}$ ,  $C_{VDD25} = 100\text{nF}$  and  $C_{REF} = 100\text{nF}$ . (Note 2)

SYMBOL	PARAMETER	CONDITIONS	MIN	TYP	MAX	UNITS
$t_{UPDATE\_ADC}$	Update Time	Odd Numbered Channels in Current Sense Mode (Note 5)		160		ms
$C_{IN\_ADC}$	Input Sampling Capacitance			1		pF
$f_{IN\_ADC}$	Input Sampling Frequency			62.5		kHz
$I_{IN\_ADC}$	Input Leakage Current	$V_{IN\_ADC} = 0\text{V}$ , $0\text{V} \leq V_{COMMONMODE} \leq 6\text{V}$ , Current Sense Mode	●		±0.5	μA
	Differential Input Current	$V_{IN\_ADC} = 0.17\text{V}$ , Current Sense Mode	●	80	250	nA
		$V_{IN\_ADC} = 6\text{V}$ , Voltage Sense Mode	●	10	15	μA

**DAC Output Characteristics**

$N\_VDACP$	Resolution			10		Bits	
$V_{FS\_VDACP}$	Full-Scale Output Voltage (Programmable)	DAC Code = 0x3FF	●	1.32	1.38	1.44	V
		DAC Polarity = 1	●	2.53	2.65	2.77	V
$INL\_VDACP$	Integral Nonlinearity	(Note 6)	●		±2	LSB	
$DNL\_VDACP$	Differential Nonlinearity	(Note 6)	●		±2.4	LSB	
$V_{OS\_VDACP}$	Offset Voltage	(Note 6)	●		±10	mV	
$V_{DACP}$	Load Regulation ( $V_{DACPn} - V_{DACMn}$ )	$V_{DACPn} = 2.65\text{V}$ , $I_{VDACPn}$ Sourcing = 2mA		100		ppm/mA	
		$V_{DACPn} = 0.1\text{V}$ , $I_{VDACPn}$ Sinking = 2mA		100		ppm/mA	
	PSRR ( $V_{DACPn} - V_{DACMn}$ )	DC: $3.13\text{V} \leq V_{DD33} \leq 3.47\text{V}$ , $V_{PWR} = V_{DD33}$		60		dB	
		100mV Step in 20ns with 50pF Load		40		dB	
	DC CMRR ( $V_{DACPn} - V_{DACMn}$ )	$-0.1\text{V} \leq V_{DACMn} \leq 0.1\text{V}$		60		dB	
	Leakage Current	$V_{DACPn}$ Hi-Z, $0\text{V} \leq V_{DACPn} \leq 6\text{V}$	●		±100	nA	
	Short-Circuit Current Low	$V_{DACPn}$ Shorted to GND	●	-10		-4	mA
Short-Circuit Current High	$V_{DACPn}$ Shorted to $V_{DD33}$	●	4		10	mA	
$C_{OUT}$	Output Capacitance	$V_{DACPn}$ Hi-Z		10		pF	
$t_{S\_VDACP}$	DAC Output Update Rate	Fast Servo Mode		500		μs	

**Voltage Supervisor Characteristics**

$V_{IN\_VS}$	Input Voltage Range (Programmable)	$V_{IN\_VS} = (V_{SENSEPN} - V_{SENSEMn})$	Low Resolution Mode	●	0	6	V
			High Resolution Mode	●	0	3.8	V
		Single-Ended Voltage: $V_{SENSEMn}$		●	-0.1	0.1	V
$N\_VS$	Voltage Sensing Resolution	0V to 3.8V Range: High Resolution Mode		4		mV/LSB	
		0V to 6V Range: Low Resolution Mode		8		mV/LSB	
$TUE\_VS$	Total Unadjusted Error	$2\text{V} \leq V_{IN\_VS} \leq 6\text{V}$ , Low Resolution Mode	●		±1.25	% of Reading	
		$1.5\text{V} < V_{IN\_VS} \leq 3.8\text{V}$ , High Resolution Mode	●		±1.0	% of Reading	
		$0.8\text{V} \leq V_{IN\_VS} \leq 1.5\text{V}$ , High Resolution Mode	●		±1.5	% of Reading	
$t_{S\_VS}$	Update Period			12.21		μs	

 **$V_{IN\_SNS}$  Input Characteristics**

$V_{IN\_SNS}$	$V_{IN\_SNS}$ Input Voltage Range		●	0	15	V	
$R_{IN\_SNS}$	$V_{IN\_SNS}$ Input Resistance		●	70	90	110	kΩ

**ELECTRICAL CHARACTERISTICS** The ● denotes the specifications which apply over the full operating temperature range, otherwise specifications are at  $T_J = 25^\circ\text{C}$ .  $V_{PWR} = V_{IN\_SNS} = 12\text{V}$ ;  $V_{DD33}$ ,  $V_{DD25}$ , REFP and REFM pins floating, unless otherwise indicated.  $C_{VDD33} = 100\text{nF}$ ,  $C_{VDD25} = 100\text{nF}$  and  $C_{REF} = 100\text{nF}$ . (Note 2)

SYMBOL	PARAMETER	CONDITIONS		MIN	TYP	MAX	UNITS
TUE <sub>VIN_SNS</sub>	VIN_ON, VIN_OFF Threshold Total Unadjusted Error	$3\text{V} \leq V_{VIN\_SNS} \leq 8\text{V}$	●			±2.0	% of Reading
		$V_{VIN\_SNS} > 8\text{V}$	●			±1.0	
	READ_VIN Total Unadjusted Error	$3\text{V} \leq V_{VIN\_SNS} \leq 8\text{V}$	●			±1.5	% of Reading
		$V_{VIN\_SNS} > 8\text{V}$	●			±1.0	
<b>DAC Soft-Connect Comparator Characteristics</b>							
V <sub>OS_CMP</sub>	Offset Voltage	$V_{DACPn} = 0.2\text{V}$	●		±1	±18	mV
		$V_{DACPn} = 1.3\text{V}$	●		±2	±26	mV
		$V_{DACPn} = 2.65\text{V}$	●		±3	±52	mV
<b>Temperature Sensor Characteristics</b>							
TUE <sub>TS</sub>	Total Unadjusted Error				±1		°C
<b>V<sub>OUT_ENn</sub> Output (V<sub>OUT_EN</sub> [3:0]) Characteristics</b>							
V <sub>VOUT_ENn</sub>	Output High Voltage (Note 11)	$I_{VOUT\_ENn} = -5\mu\text{A}$ , $V_{DD33} = 3.3\text{V}$	●	10	12.5	14.7	V
I <sub>VOUT_ENn</sub>	Output Sourcing Current	$V_{VOUT\_ENn}$ Pull-Up Enabled, $V_{VOUT\_ENn} = 1\text{V}$	●	-5	-6	-8	μA
	Output Sinking Current	Strong Pull-Down Enabled, $V_{VOUT\_ENn} = 0.4\text{V}$	●	3	5	8	mA
		Weak Pull-Down Enabled, $V_{VOUT\_ENn} = 0.4\text{V}$	●	28	43	60	μA
	Output Leakage Current	Internal Pull-Up Disabled, $0\text{V} \leq V_{VOUT\_ENn} \leq 15\text{V}$	●			±1	μA
V <sub>VOUT_VALID</sub>	Minimum $V_{DD33}$ when $V_{VOUT\_ENn}$ Valid	$V_{VOUT\_ENn} \leq 0.4\text{V}$	●			1.1	V
<b>V<sub>OUT_ENn</sub> Output (V<sub>OUT_EN</sub> [7:4]) Characteristics</b>							
I <sub>VOUT_ENn</sub>	Output Sinking Current	Strong Pull-Down Enabled, $V_{VOUT\_ENn} = 0.1\text{V}$			6		mA
	Output Leakage Current	$0\text{V} \leq V_{VOUT\_ENn} \leq 6\text{V}$	●			±1	μA
V <sub>VOUT_VALID</sub>	Minimum $V_{DD33}$ when $V_{VOUT\_ENn}$ Valid	$V_{VOUT\_ENn} \leq 0.4\text{V}$	●			1.1	V
<b>V<sub>IN_EN</sub> Output (V<sub>IN_EN</sub>) Characteristics</b>							
V <sub>VIN_EN</sub>	Output High Voltage	$I_{VIN\_EN} = -5\mu\text{A}$ , $V_{DD33} = 3.3\text{V}$	●	10	12.5	14.7	V
I <sub>VIN_EN</sub>	Output Sourcing Current	$V_{VIN\_EN}$ Pull-Up Enabled, $V_{VIN\_EN} = 1\text{V}$	●	-5	-6	-8	μA
	Output Sinking Current	$V_{VIN\_EN} = 0.4\text{V}$	●	3	5	8	mA
	Leakage Current	Internal Pull-Up Disabled, $0\text{V} \leq V_{VIN\_EN} \leq 15\text{V}$	●			±1	μA
<b>EEPROM Characteristics</b>							
Endurance	(Notes 7, 10)	$0^\circ\text{C} < T_J < 85^\circ\text{C}$ During EEPROM Write Operations	●	10,000			Cycles
Retention	(Notes 7, 10)	$T_J < 105^\circ\text{C}$	●	20			Years
t <sub>MASS_WRITE</sub>	Mass Write Operation Time (Note 8)	STORE_USER_ALL, $0^\circ\text{C} < T_J < 85^\circ\text{C}$ During EEPROM Write Operations	●		440	4100	ms

**ELECTRICAL CHARACTERISTICS** The ● denotes the specifications which apply over the full operating temperature range, otherwise specifications are at  $T_J = 25^\circ\text{C}$ .  $V_{PWR} = V_{IN\_SNS} = 12\text{V}$ ;  $V_{DD33}$ ,  $V_{DD25}$ , REFP and REFM pins floating, unless otherwise indicated.  $C_{VDD33} = 100\text{nF}$ ,  $C_{VDD25} = 100\text{nF}$  and  $C_{REF} = 100\text{nF}$ . (Note 2)

SYMBOL	PARAMETER	CONDITIONS	MIN	TYP	MAX	UNITS	
<b>Digital Inputs SCL, SDA, CONTROL0, CONTROL1, WDI/RESETB, FAULTB00, FAULTB01, FAULTB10, FAULTB11, WP</b>							
$V_{IH}$	High Level Input Voltage		●	2.1		V	
$V_{IL}$	Low Level Input Voltage		●		1.5	V	
$V_{HYST}$	Input Hysteresis			20		mV	
$I_{LEAK}$	Input Leakage Current	$0\text{V} \leq V_{PIN} \leq 5.5\text{V}$ , SDA, SCL, CONTROL $n$ Pins Only	●		$\pm 2$	$\mu\text{A}$	
		$0\text{V} \leq V_{PIN} \leq V_{DD33} + 0.3\text{V}$ , FAULTB $zn$ , WDI/RESETB, WP Pins Only	●		$\pm 2$	$\mu\text{A}$	
$t_{SP}$	Pulse Width of Spike Suppressed	FAULTB $zn$ , CONTROL $n$ Pins Only		10		$\mu\text{s}$	
		SDA, SCL Pins Only		98		ns	
$t_{FAULT\_MIN}$	Minimum Low Pulse Width for Externally Generated Faults		110			ms	
$t_{RESETB}$	Pulse Width to Assert Reset	$V_{WDI/RESETB} \leq 1.5\text{V}$	●	300		$\mu\text{s}$	
$t_{WDI}$	Pulse Width to Reset Watchdog Timer	$V_{WDI/RESETB} \leq 1.5\text{V}$	●	0.3	200	$\mu\text{s}$	
$f_{WDI}$	Watchdog Interrupt Input Frequency		●		1	MHz	
$C_{IN}$	Digital Input Capacitance			10		pF	
<b>Digital Input SHARE_CLK</b>							
$V_{IH}$	High Level Input Voltage		●	1.6		V	
$V_{IL}$	Low Level Input Voltage		●		0.8	V	
$f_{SHARE\_CLK\_IN}$	Input Frequency Operating Range		●	90	110	kHz	
$t_{LOW}$	Assertion Low Time	$V_{SHARE\_CLK} < 0.8\text{V}$	●	0.825	1.1	$\mu\text{s}$	
$t_{RISE}$	Rise Time	$V_{SHARE\_CLK} < 0.8\text{V}$ to $V_{SHARE\_CLK} > 1.6\text{V}$	●		450	ns	
$I_{LEAK}$	Input Leakage Current	$0\text{V} \leq V_{SHARE\_CLK} \leq V_{DD33} + 0.3\text{V}$	●		$\pm 1$	$\mu\text{A}$	
$C_{IN}$	Input Capacitance			10		pF	
<b>Digital Outputs SDA, ALERTB, PWRGD, SHARE_CLK, FAULTB00, FAULTB01, FAULTB10, FAULTB11</b>							
$V_{OL}$	Digital Output Low Voltage	$I_{SINK} = 3\text{mA}$	●		0.4	V	
$f_{SHARE\_CLK\_OUT}$	Output Frequency Operating Range	5.49k $\Omega$ Pull-Up to $V_{DD33}$	●	90	100	110	kHz
<b>Digital Inputs ASELO,ASEL1</b>							
$V_{IH}$	Input High Threshold Voltage		●	$V_{DD33} - 0.5$		V	
$V_{IL}$	Input Low Threshold Voltage		●		0.5	V	
$I_{IH,IL}$	High, Low Input Current	ASEL[1:0] = 0, $V_{DD33}$	●		$\pm 95$	$\mu\text{A}$	
$I_{HIZ}$	Hi-Z Input Current		●		$\pm 24$	$\mu\text{A}$	
$C_{IN}$	Input Capacitance			10		pF	
<b>Serial Bus Timing Characteristics</b>							
$f_{SCL}$	Serial Clock Frequency (Note 9)		●	10	400	kHz	
$t_{LOW}$	Serial Clock Low Period (Note 9)		●	1.3		$\mu\text{s}$	
$t_{HIGH}$	Serial Clock High Period (Note 9)		●	0.6		$\mu\text{s}$	
$t_{BUF}$	Bus Free Time Between Stop and Start (Note 9)		●	1.3		$\mu\text{s}$	
$t_{HD,STA}$	Start Condition Hold Time (Note 9)		●	600		ns	
$t_{SU,STA}$	Start Condition Setup Time (Note 9)		●	600		ns	
$t_{SU,STO}$	Stop Condition Setup Time (Note 9)		●	600		ns	

**ELECTRICAL CHARACTERISTICS** The ● denotes the specifications which apply over the full operating temperature range, otherwise specifications are at  $T_J = 25^\circ\text{C}$ .  $V_{\text{PWR}} = V_{\text{IN\_SNS}} = 12\text{V}$ ;  $V_{\text{DD33}}$ ,  $V_{\text{DD25}}$ , REFP and REFM pins floating, unless otherwise indicated.  $C_{\text{VDD33}} = 100\text{nF}$ ,  $C_{\text{VDD25}} = 100\text{nF}$  and  $C_{\text{REF}} = 100\text{nF}$ . (Note 2)

SYMBOL	PARAMETER	CONDITIONS	MIN	TYP	MAX	UNITS
$t_{\text{HD,DAT}}$	Data Hold Time (LTC2977 Receiving Data) (Note 9)		●	0		ns
	Data Hold Time (LTC2977 Transmitting Data) (Note 9)		●	300	900	ns
$t_{\text{SU,DAT}}$	Data Setup Time (Note 9)		●	100		ns
$t_{\text{SP}}$	Pulse Width of Spike Suppressed (Note 9)			98		ns
$t_{\text{TIMEOUT\_BUS}}$	Time Allowed to Complete any PMBus Command After Which Time SDA Will Be Released and Command Terminated	Mfr_config_all_longer_pmbus_timeout = 0	●	25	35	ms
		Mfr_config_all_longer_pmbus_timeout = 1	●	200	280	ms

#### Additional Digital Timing Characteristics

$t_{\text{OFF\_MIN}}$	Minimum Off Time for Any Channel			100		ms
-----------------------	----------------------------------	--	--	-----	--	----

**Note 1:** Stresses beyond those listed under Absolute Maximum Ratings may cause permanent damage to the device. Exposure to any Absolute Maximum Rating for extended periods may affect device reliability and lifetime.

**Note 2:** All currents into device pins are positive. All currents out of device pins are negative. All voltages are referenced to GND unless otherwise specified. If power is supplied to the chip via the  $V_{\text{DD33}}$  pin only, connect  $V_{\text{PWR}}$  and  $V_{\text{DD33}}$  pins together.

**Note 3:** The ADC total unadjusted error includes all error sources. First, a two-point analog trim is performed to achieve a flat reference voltage ( $V_{\text{REF}}$ ) over temperature. This results in minimal temperature coefficient, but the absolute voltage can still vary. To compensate for this, a high-resolution, drift-free, and noiseless digital trim is applied at the output of the ADC, resulting in a very high accuracy measurement.

**Note 4:** Hysteresis in the output voltage is created by package stress that differs depending on whether the IC was previously at a higher or lower temperature. Output voltage is always measured at  $25^\circ\text{C}$ , but the IC is cycled to  $105^\circ\text{C}$  or  $-40^\circ\text{C}$  before successive measurements. Hysteresis is roughly proportional to the square of the temperature change.

**Note 5:** The time between successive ADC conversions (latency of the ADC) for any given channel is given as:  $36.9\text{ms} + (6.15\text{ms} \cdot \text{number of ADC channels configured in Low Resolution mode}) + (24.6\text{ms} \cdot \text{number of ADC channels configured in High Resolution mode})$ .

**Note 6:** Nonlinearity is defined from the first code that is greater than or equal to the maximum offset specification to full-scale code, 1023.

**Note 7:** EEPROM endurance and retention are guaranteed by design, characterization and correlation with statistical process controls. The minimum retention specification applies for devices whose EEPROM has been cycled less than the minimum endurance specification.

**Note 8:** The LTC2977 will not acknowledge any PMBus commands except for MFR\_COMMON, while a mass write operation is being executed. This includes the STORE\_USER\_ALL and MFR\_FAULT\_LOG\_STORE commands or a fault log store initiated by a channel faulting off.

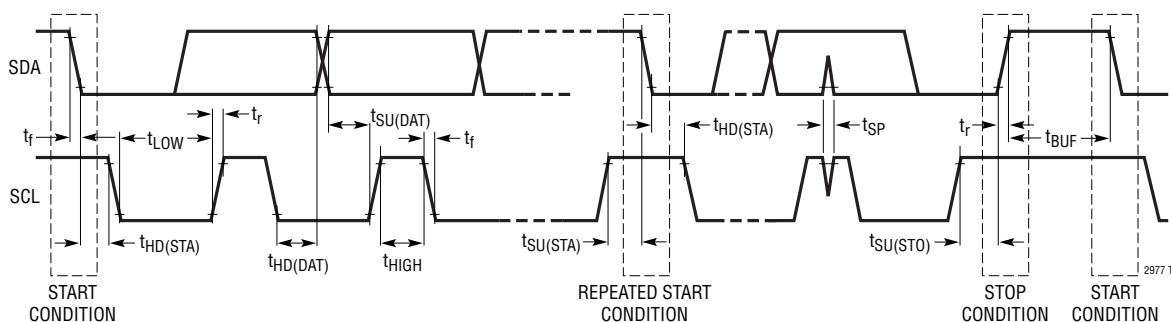
**Note 9:** Maximum capacitive load,  $C_B$ , for SCL and SDA is  $400\text{pF}$ . Data and clock rise time ( $t_r$ ) and fall time ( $t_f$ ) are:  $(20 + 0.1 \cdot C_B) \text{ (ns)} < t_r < 300\text{ns}$  and  $(20 + 0.1 \cdot C_B) \text{ (ns)} < t_f < 300\text{ns}$ .  $C_B$  = capacitance of one bus line in pF. SCL and SDA external pull-up voltage,  $V_{\text{IO}}$ , is  $3.13\text{V} < V_{\text{IO}} < 5.5\text{V}$ .

**Note 10:** EEPROM endurance and retention will be degraded when  $T_J > 105^\circ\text{C}$ .

**Note 11:** Output enable pins are charge-pumped from  $V_{\text{DD33}}$ .

**Note 12:** The current sense resolution is determined by the L11 format and the mV units of the returned value. For example, a full-scale value of  $170\text{mV}$  returns an L11 value of  $0xF2A8 = 680 \cdot 2^{-2} = 170$ . This is the lowest range that can represent this value without overflowing the L11 mantissa and the resolution for 1LSB in this range is  $2^{-2} \text{ mV} = 250\mu\text{V}$ . Each successively lower range improves resolution by cutting the LSB size in half.

## PMBUS TIMING DIAGRAM

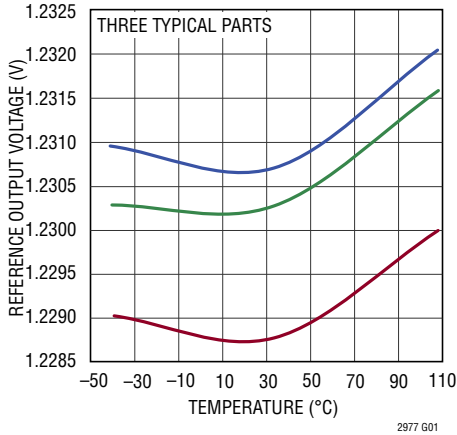


2977 TD

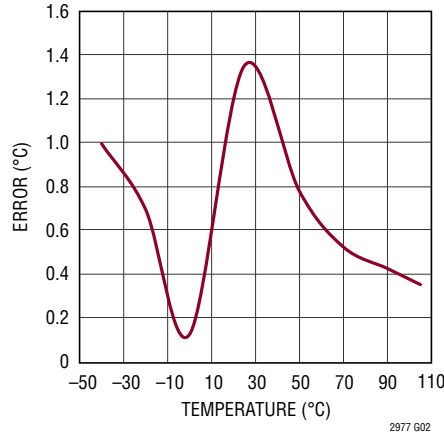
Rev. G

# TYPICAL PERFORMANCE CHARACTERISTICS

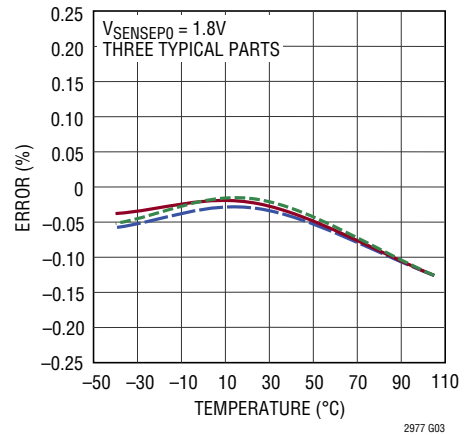
Reference Voltage vs Temperature



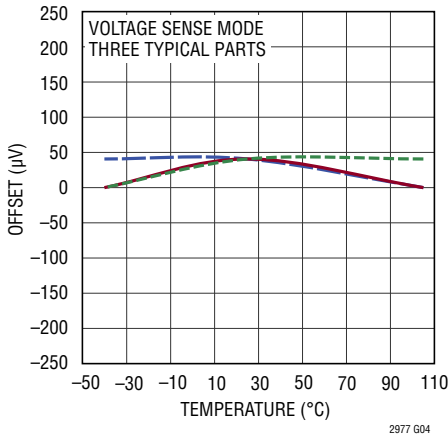
Temperature Sensor Error vs Temperature



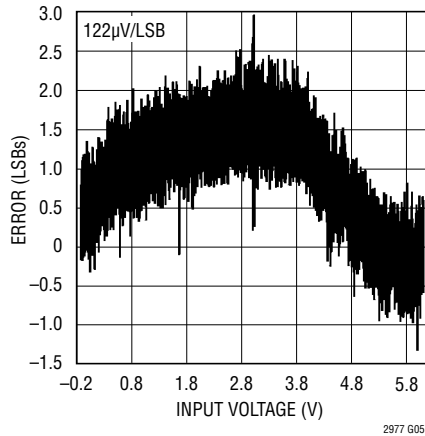
ADC Total Unadjusted Error vs Temperature



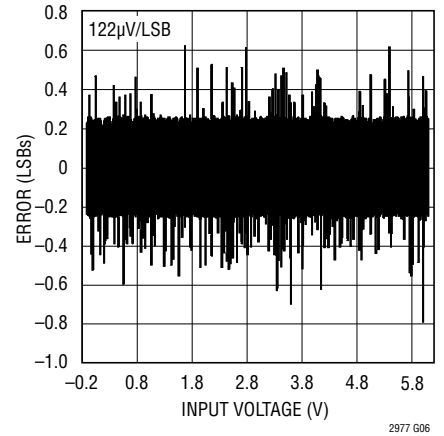
ADC Zero Code Center Offset Voltage vs Temperature



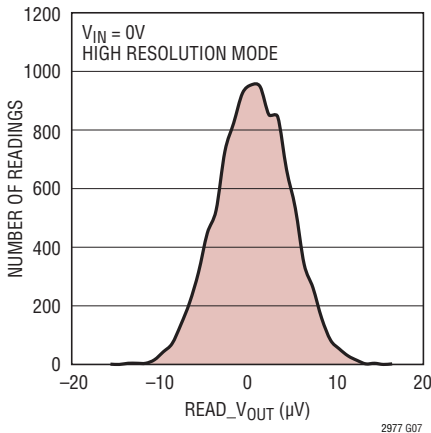
ADC-INL



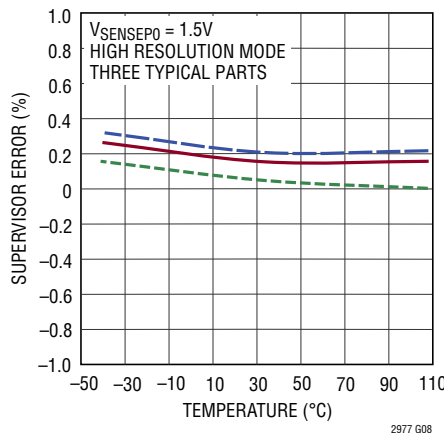
ADC-DNL



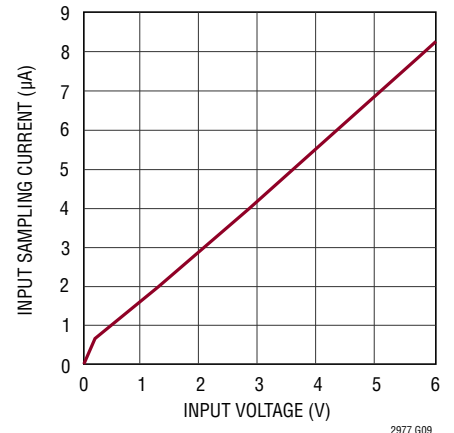
ADC Noise Histogram



Voltage Supervisor Total Unadjusted Error vs Temperature

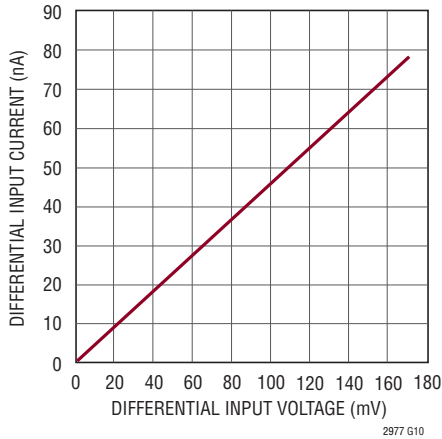


Input Sampling Current vs Differential Input Voltage

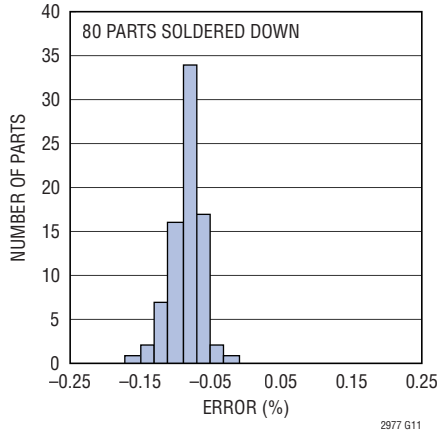


# TYPICAL PERFORMANCE CHARACTERISTICS

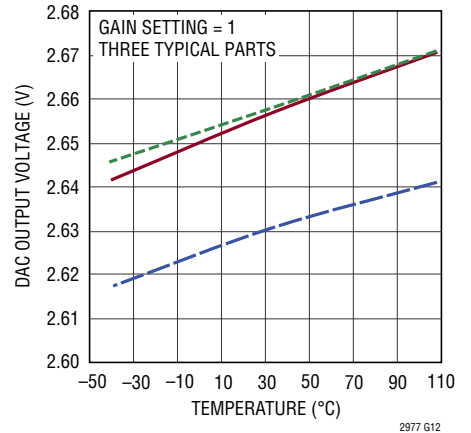
**ADC High Resolution Mode  
Differential Input Current**



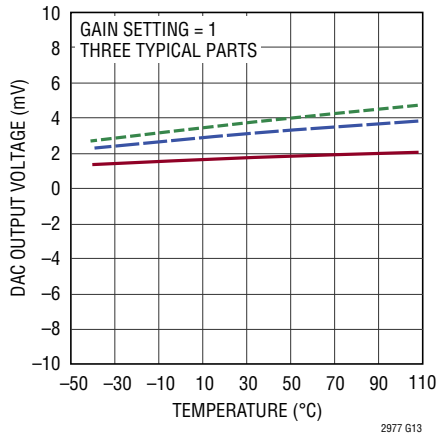
**Closed-Loop Servo Error**



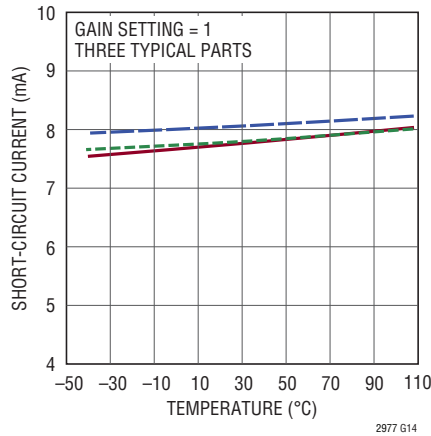
**DAC Full-Scale Output Voltage vs  
Temperature**



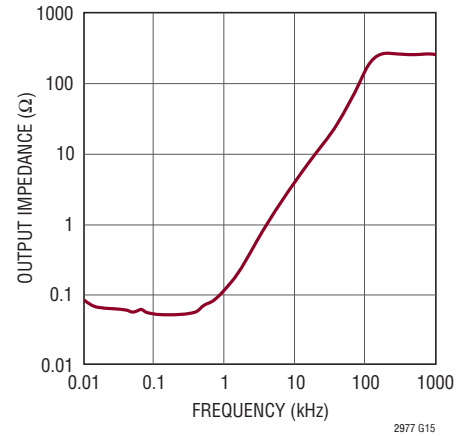
**DAC Offset Voltage vs  
Temperature**



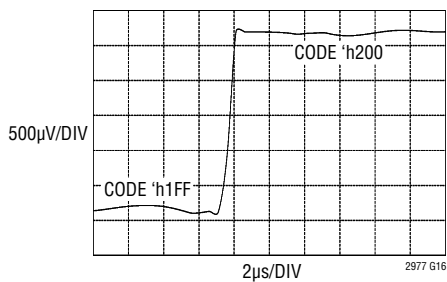
**DAC Short-Circuit Current vs  
Temperature**



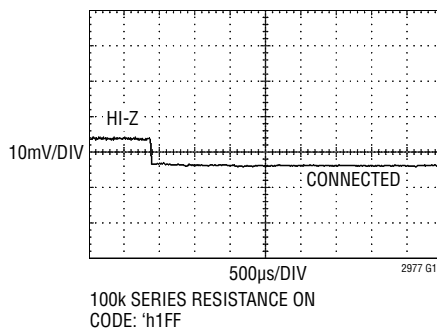
**DAC Output Impedance vs  
Frequency**



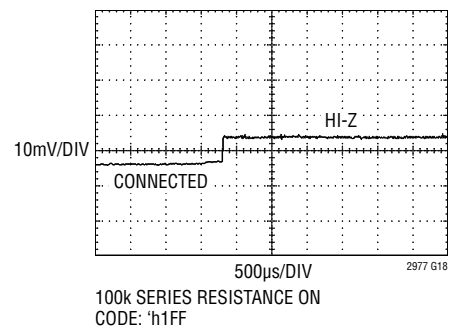
**DAC Transient Response to 1LSB  
DAC Code Change**



**DAC Soft-Connect Transient  
Response when Transitioning from  
Hi-Z State to ON State**

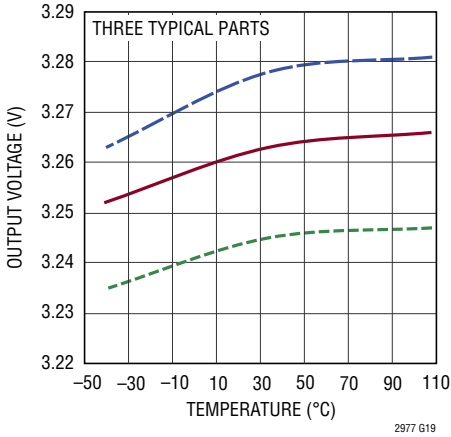


**DAC Soft-Connect Transient  
Response when Transitioning from  
ON State to Hi-Z State**

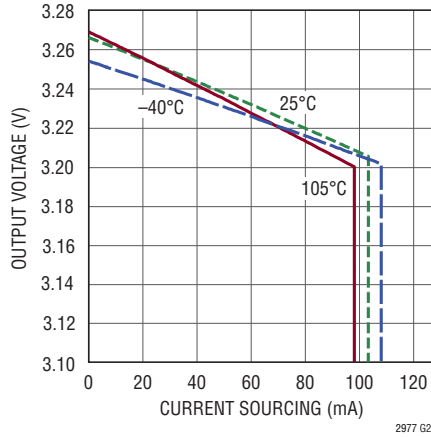


# TYPICAL PERFORMANCE CHARACTERISTICS

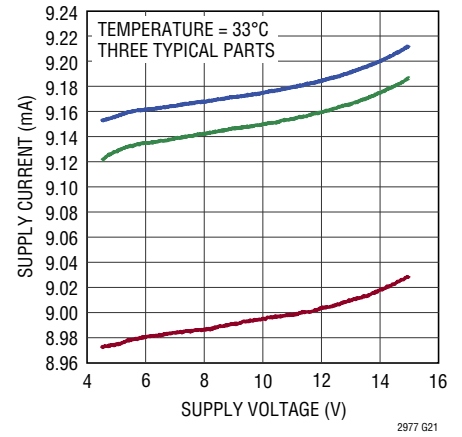
**V<sub>DD33</sub> Regulator Output Voltage vs Temperature**



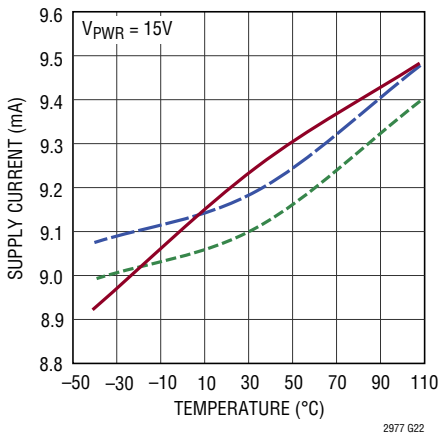
**V<sub>DD33</sub> Regulator Load Regulation**



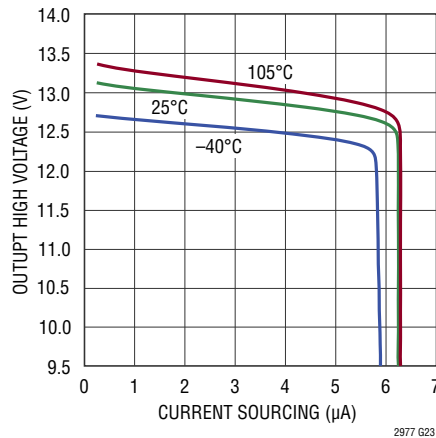
**Supply Current vs Supply Voltage**



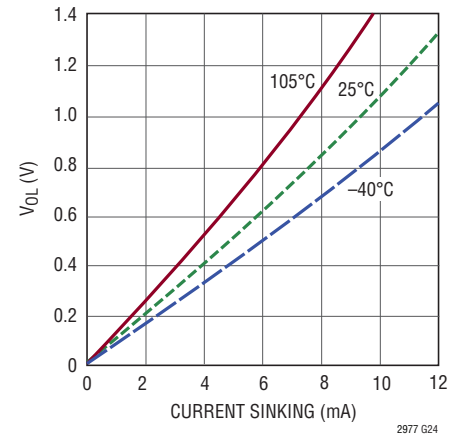
**Supply Current vs Temperature**



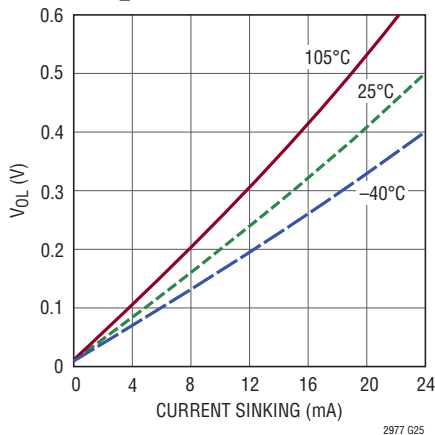
**V<sub>OUT\_EN[3:0]</sub> and V<sub>IN\_EN</sub> Output High Voltage vs Current**



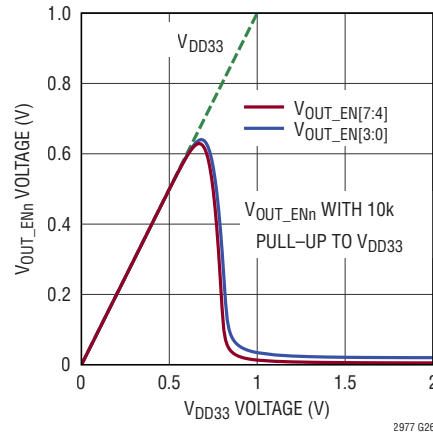
**V<sub>OUT\_EN[3:0]</sub> and V<sub>IN\_EN</sub> Output V<sub>OL</sub> vs Current**



**V<sub>OUT\_EN[7:4]</sub> V<sub>OL</sub> vs Current**



**V<sub>OUT\_EN[7:0]</sub> Output Voltage vs V<sub>DD33</sub>**



## PIN FUNCTIONS

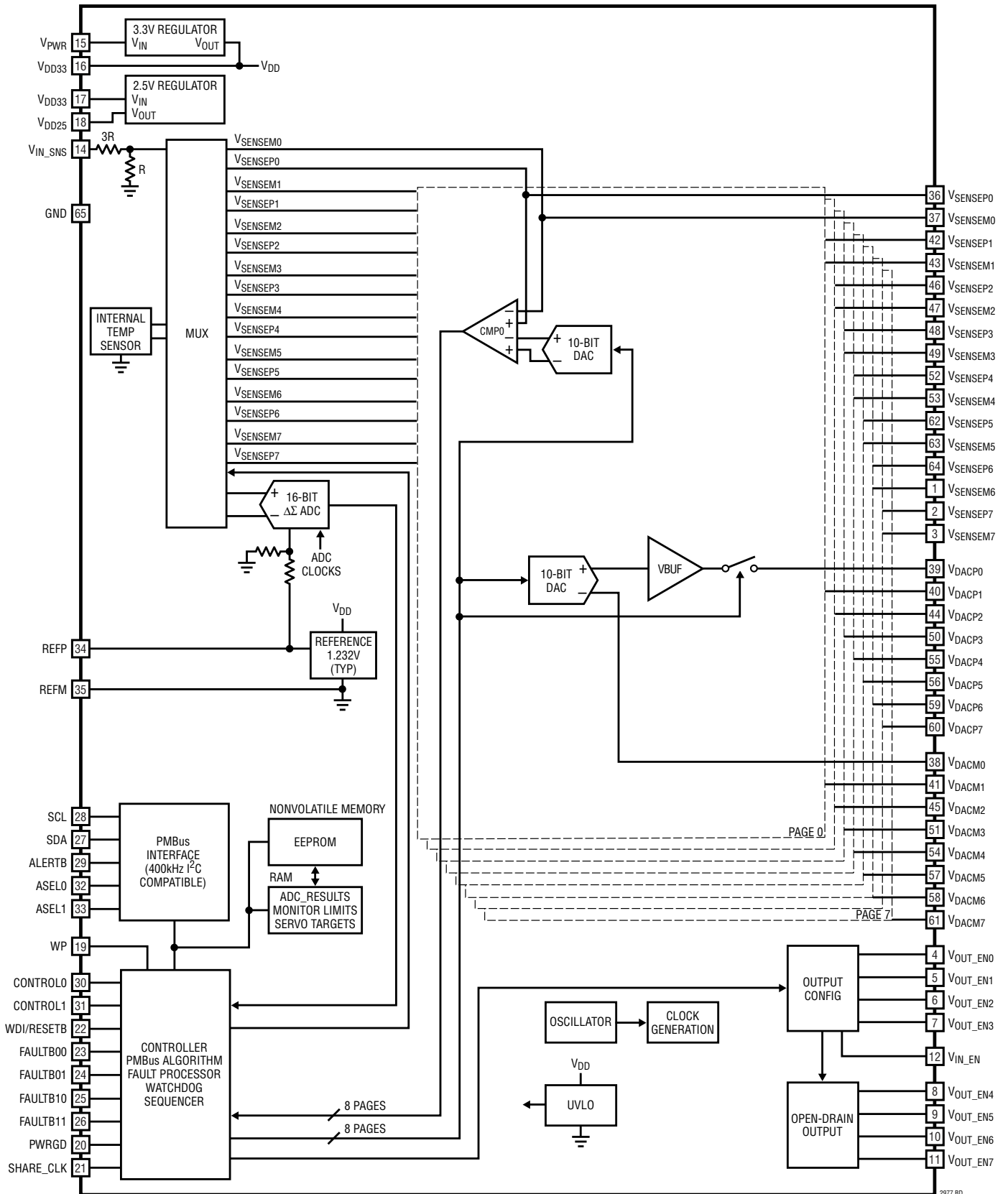
PIN NAME	PIN NUMBER	PIN TYPE	DESCRIPTION
V <sub>SENSE6</sub>	1*	In	DC/DC Converter Differential (-) Output Voltage-6 Sensing Pin
V <sub>SENSE7</sub>	2*	In	DC/DC Converter Differential (+) Output Voltage or Current-7 Sensing Pin
V <sub>SENSE7</sub>	3*	In	DC/DC Converter Differential (-) Output Voltage or Current-7 Sensing Pin
V <sub>OUT_EN0</sub>	4	Out	DC/DC Converter Enable-0 Pin. Output High Voltage Optionally Pulled Up to 12V by 5 $\mu$ A
V <sub>OUT_EN1</sub>	5	Out	DC/DC Converter Enable-1 Pin. Output High Voltage Optionally Pulled Up to 12V by 5 $\mu$ A
V <sub>OUT_EN2</sub>	6	Out	DC/DC Converter Enable-2 Pin. Output High Voltage Optionally Pulled Up to 12V by 5 $\mu$ A
V <sub>OUT_EN3</sub>	7	Out	DC/DC Converter Enable-3 Pin. Output High Voltage Optionally Pulled Up to 12V by 5 $\mu$ A
V <sub>OUT_EN4</sub>	8	Out	DC/DC Converter Enable-4 Pin. Open-Drain Pull-Down Output.
V <sub>OUT_EN5</sub>	9	Out	DC/DC Converter Enable-5 Pin. Open-Drain Pull-Down Output.
V <sub>OUT_EN6</sub>	10	Out	DC/DC Converter Enable-6 Pin. Open-Drain Pull-Down Output.
V <sub>OUT_EN7</sub>	11	Out	DC/DC Converter Enable-7 Pin. Open-Drain Pull-Down Output.
V <sub>IN_EN</sub>	12	Out	DC/DC Converter V <sub>IN</sub> ENABLE Pin. Output High Voltage Optionally Pulled Up to 12V by 5 $\mu$ A
DNC	13	Do Not Connect	Do Not Connect to This Pin
V <sub>IN_SNS</sub>	14	In	V <sub>IN</sub> SENSE Input. This Voltage is Compared Against the V <sub>IN</sub> On and Off Voltage Thresholds in Order to Determine When to Enable and Disable, Respectively, the Downstream DC/DC Converters.
V <sub>PWR</sub>	15	In	V <sub>PWR</sub> Serves as the Unregulated Power Supply Input to the Chip (4.5V to 15V). If a 4.5V to 15V Supply Voltage is Unavailable, Short V <sub>PWR</sub> to V <sub>DD33</sub> and Power the Chip Directly from a 3.3V Supply. Bypass to GND with 0.1 $\mu$ F Capacitor.
V <sub>DD33</sub>	16	In/Out	If Shorted to V <sub>PWR</sub> , it Serves as 3.13V to 3.47V Supply Input Pin. Otherwise, it is a 3.3V Internally Regulated Voltage Output (Use 0.1 $\mu$ F Decoupling Capacitor to GND). If using the internal regulator to provide V <sub>DD33</sub> , only connect the pull-up resistors and bypass capacitors required to support the LTC2977 in the application.
V <sub>DD33</sub>	17	In	Input for Internal 2.5V Sub-Regulator. Short This Pin to Pin 16. If using the internal regulator to provide V <sub>DD33</sub> , only connect the pull-up resistors and bypass capacitors required to support the LTC2977 in the application.
V <sub>DD25</sub>	18	In/Out	2.5V Internally Regulated Voltage Output. Bypass to GND with a 0.1 $\mu$ F Capacitor, only connect the pull-up resistors and bypass capacitors required to support the LTC2977 in the application.
WP	19	In	Digital Input. Write-Protect Input Pin, Active High.
PWRGD	20	Out	Power Good Open-Drain Output. Indicates When Outputs are Power Good. Can be Used as System Power-On Reset.
SHARE_CLK	21	In/Out	Bidirectional Clock Sharing Pin. Connect a 5.49k Pull-Up Resistor to V <sub>DD33</sub> . Connect to all other SHARE_CLK pins in the system.
WDI/RESETB	22	In	Watchdog Timer Interrupt and Chip Reset Input. Connect a 10k Pull-Up Resistor to V <sub>DD33</sub> . Rising Edge Resets Watchdog Counter. Holding This Pin Low for More Than t <sub>RESETB</sub> Resets the Chip.
FAULTB00	23	In/Out	Open-Drain Output and Digital Input. Active Low Bidirectional Fault Indicator-00. Connect a 10k Pull-Up Resistor to V <sub>DD33</sub> .
FAULTB01	24	In/Out	Open-Drain Output and Digital Input. Active Low Bidirectional Fault Indicator-01. Connect a 10k Pull-Up Resistor to V <sub>DD33</sub> .
FAULTB10	25	In/Out	Open-Drain Output and Digital Input. Active Low Bidirectional Fault Indicator-10. Connect a 10k Pull-Up Resistor to V <sub>DD33</sub> .
FAULTB11	26	In/Out	Open-Drain Output and Digital Input. Active Low Bidirectional Fault Indicator-11. Connect a 10k Pull-Up Resistor to V <sub>DD33</sub> .
SDA	27	In/Out	PMBus Bidirectional Serial Data Pin
SCL	28	In	PMBus Serial Clock Input Pin (400kHz Maximum)
ALERTB	29	Out	Open-Drain Output. Generates an Interrupt Request in a Fault/Warning Situation.
CONTROL0	30	In	Control Pin 0 Input
CONTROL1	31	In	Control Pin 1 Input
ASEL0	32	In	Ternary Address Select Pin 0 Input. Connect to V <sub>DD33</sub> , GND or Float to Encode 1 of 3 Logic States.
ASEL1	33	In	Ternary Address Select Pin 1 Input. Connect to V <sub>DD33</sub> , GND or Float to Encode 1 of 3 Logic States.
REFP	34	Out	Reference Voltage Output. Needs 0.1 $\mu$ F Decoupling Capacitor to REFM.
REFM	35	Out	Reference Return Pin. Needs 0.1 $\mu$ F Decoupling Capacitor to REFP.

## PIN FUNCTIONS

PIN NAME	PIN NUMBER	PIN TYPE	DESCRIPTION
V <sub>SENSE</sub> P0	36*	In	DC/DC Converter Differential (+) Output Voltage-0 Sensing Pin
V <sub>SENSE</sub> M0	37*	In	DC/DC Converter Differential (-) Output Voltage-0 Sensing Pin
V <sub>DAC</sub> M0	38	Out	DAC0 Return. Connect to Channel 0 DC/DC Converter's GND Sense or Return to GND.
V <sub>DAC</sub> P0	39	Out	DAC0 Output
V <sub>DAC</sub> P1	40	Out	DAC1 Output
V <sub>DAC</sub> M1	41	Out	DAC1 Return. Connect to Channel 1 DC/DC Converter's GND Sense or Return to GND.
V <sub>SENSE</sub> P1	42*	In	DC/DC Converter Differential (+) Output Voltage or Current-1 Sensing Pins
V <sub>SENSE</sub> M1	43*	In	DC/DC Converter Differential (-) Output Voltage or Current-1 Sensing Pins
V <sub>DAC</sub> P2	44	Out	DAC2 Output
V <sub>DAC</sub> M2	45	Out	DAC2 Return. Connect to Channel 2 DC/DC Converter's GND Sense or Return to GND.
V <sub>SENSE</sub> P2	46*	In	DC/DC Converter Differential (+) Output Voltage-2 Sensing Pin
V <sub>SENSE</sub> M2	47*	In	DC/DC Converter Differential (-) Output Voltage-2 Sensing Pin
V <sub>SENSE</sub> P3	48*	In	DC/DC Converter Differential (+) Output Voltage or Current-3 Sensing Pins
V <sub>SENSE</sub> M3	49*	In	DC/DC Converter Differential (-) Output Voltage or Current-3 Sensing Pins
V <sub>DAC</sub> P3	50	Out	DAC3 Output
V <sub>DAC</sub> M3	51	Out	DAC3 Return. Connect to Channel 3 DC/DC Converter's GND Sense or Return to GND.
V <sub>SENSE</sub> P4	52*	In	DC/DC Converter Differential (+) Output Voltage-4 Sensing Pin
V <sub>SENSE</sub> M4	53*	In	DC/DC Converter Differential (-) Output Voltage-4 Sensing Pin
V <sub>DAC</sub> M4	54	Out	DAC4 Return. Connect to Channel 4 DC/DC Converter's GND Sense or Return to GND.
V <sub>DAC</sub> P4	55	Out	DAC4 Output
V <sub>DAC</sub> P5	56	Out	DAC5 Output
V <sub>DAC</sub> M5	57	Out	DAC5 Return. Connect to Channel 5 DC/DC Converter's GND Sense or Return to GND.
V <sub>DAC</sub> M6	58	Out	DAC6 Return. Connect to Channel 6 DC/DC Converter's GND Sense or Return to GND.
V <sub>DAC</sub> P6	59	Out	DAC6 Output
V <sub>DAC</sub> P7	60	Out	DAC7 Output
V <sub>DAC</sub> M7	61	Out	DAC7 Return. Connect to Channel 7 DC/DC Converter's GND Sense or Return to GND.
V <sub>SENSE</sub> P5	62*	In	DC/DC Converter Differential (+) Output Voltage or Current-5 Sensing Pins
V <sub>SENSE</sub> M5	63*	In	DC/DC Converter Differential (-) Output Voltage or Current-5 Sensing Pins
V <sub>SENSE</sub> P6	64*	In	DC/DC Converter Differential (+) Output Voltage-6 Sensing Pin
GND	65	Ground	Exposed Pad, Must be Soldered to PCB

\*Any unused V<sub>SENSE</sub>P<sub>n</sub> or V<sub>SENSE</sub>M<sub>n</sub> or V<sub>DAC</sub>M<sub>n</sub> pins must be tied to GND.

# BLOCK DIAGRAM



## OPERATION

### OPERATION OVERVIEW

The LTC2977 is a PMBus programmable power system controller, monitor, sequencer and voltage supervisor that can perform the following operations:

- Accept PMBus compatible programming commands.
- Provide DC/DC converter input voltage and output voltage/current readback through the PMBus interface.
- Control the output of DC/DC converters that set the output voltage with a trim pin or DC/DC converters that set the output voltage using an external resistor feedback network.
- Sequence the start-up of DC/DC converters via PMBus programming and their control input pins. Time-based sequencing and tracking sequencing are both supported.
- Trim the DC/DC converter output voltage (typically in 0.02% steps), in closed-loop servo operating mode, through PMBus programming.
- Margin the DC/DC converter output voltage to PMBus programmed limits.
- Allow the user to trim or margin the DC/DC converter output voltage in a manual operating mode by providing direct access to the margin DAC.
- Supervise the DC/DC converter output voltage, input voltage, and the LTC2977 die temperature for over-value/undervalue conditions with respect to PMBus programmed limits and generate appropriate faults and warnings.
- Respond to a fault condition by either continuing operation indefinitely, latching off after a programmable deglitch period, latching off immediately or sequencing off after  $T_{OFF\_DELAY}$ . A retry mode may be used to automatically recover from a latched-off condition. When enabled, the number of retries (0 to 6 or infinite) is the same for all pages and is programmed in  $MFR\_RETRY\_COUNT$ .
- Optionally stop trimming the DC/DC converter output voltage after reaching the initial margin or nominal target. Optionally allow servo to resume if target drifts outside of  $V_{OUT}$  warning limits.
- Store command register contents to EEPROM with CRC and ECC through PMBus programming.
- Restore EEPROM contents through PMBus programming or when  $V_{DD33}$  is applied on power-up.
- Report the DC/DC converter output voltage status through the PMBus interface and the power good output.
- Generate interrupt requests by asserting the ALERTB pin in response to supported PMBus faults and warnings.
- Coordinate system wide fault responses for all DC/DC converters connected to the FAULTBz0 and FAULTBz1 pins.
- Synchronize sequencing delays or shutdown for multiple devices using the SHARE\_CLK pin.
- Software and hardware write protect the command registers.
- Disable the input voltage to the supervised DC/DC converters in response to output voltage OV and UV faults.
- Log telemetry and status data to EEPROM in response to a faulted-off condition
- Supervise an external microcontroller's activity for a stalled condition with a programmable watchdog timer and reset it if necessary.
- Prevent a DC/DC converter from re-entering the ON state after a power cycle until a programmable interval ( $MFR\_RESTART\_DELAY$ ) has elapsed and its output has decayed below a programmable threshold voltage ( $MFR\_VOUT\_DISCHARGE\_THRESHOLD$ ).
- Record minimum and maximum observed values of input voltage, output voltages and temperature.
- Access user EEPROM data directly, without altering RAM space ( $MFR\_EE\_UNLOCK$ ,  $MFR\_EE\_ERASE$ , and  $MFR\_EE\_DATA$ ). Facilitates in-house bulk programming.

## OPERATION

### EEPROM

The LTC2977 contains internal EEPROM (nonvolatile memory) with error-correcting code (ECC) to store configuration settings and fault log information. EEPROM endurance, retention, and mass write operation time are specified over the operating junction temperature range. See Electrical Characteristics and Absolute Maximum Ratings sections.

Nondestructive operation above  $T_J = 105^\circ\text{C}$  is possible although the Electrical Characteristics are not guaranteed and the EEPROM will be degraded.

Operating the EEPROM above  $105^\circ\text{C}$  may result in a degradation of retention characteristics. The fault logging function, which is useful in debugging system problems that may occur at high temperatures, only writes to fault log EEPROM locations. If occasional writes to these registers occur above  $105^\circ\text{C}$ , a slight degradation in the data retention characteristics of the fault log may occur.

It is recommended that the EEPROM not be written using STORE\_USER\_ALL or bulk programming when  $T_J > 85^\circ\text{C}$ .

The degradation in EEPROM retention for temperatures  $>105^\circ\text{C}$  can be approximated by calculating the dimensionless acceleration factor using the following equation.

$$AF = e^{\left[ \left( \frac{E_a}{k} \right) \cdot \left( \frac{1}{T_{\text{USE}} + 273} - \frac{1}{T_{\text{STRESS}} + 273} \right) \right]}$$

where:

AF = acceleration factor

$E_a$  = activation energy = 1.4 eV

$k = 8.617 \times 10^{-5}$  eV/°K

$T_{\text{USE}} = 105^\circ\text{C}$  specified junction temperature

$T_{\text{STRESS}}$  = actual junction temperature °C

Example: Calculate the effect on retention when operating at a junction temperature of  $125^\circ\text{C}$  for 10 hours.

$T_{\text{STRESS}} = 125^\circ\text{C}$

$T_{\text{USE}} = 105^\circ\text{C}$

AF = 8.65

Equivalent operating time at  $105^\circ\text{C} = 86.5$  hours.

So the overall retention of the EEPROM was degraded by 76.5 hours as a result of operation at a junction temperature of  $125^\circ\text{C}$  for 10 hours. Note that the effect of this overstress is negligible when compared to the overall EEPROM retention rating of 175,200 hours at a maximum junction temperature of  $105^\circ\text{C}$ .

### RESET

Holding the WDI/RESETB pin low for more than  $t_{\text{RESETB}}$  will cause the LTC2977 to enter the power-on reset state. While in the power-on reset state, the device will not communicate on the I<sup>2</sup>C bus. Following the subsequent rising-edge of the WDI/RESETB pin, the LTC2977 will execute its power-on sequence per the user configuration stored in EEPROM. Connect WDI/RESETB to  $V_{\text{DD33}}$  with a 10k resistor. WDI/RESETB includes an internal 256 $\mu\text{s}$  deglitch filter so additional filter capacitance on this pin is not recommended.

### OTHER OPERATIONS

#### Clock Sharing

Multiple LTC PMBus devices can synchronize their clocks in an application by connecting together the open-drain SHARE\_CLK input/outputs to a pull-up resistor as a wired OR. In this case the fastest clock will take over and synchronize all LTC2977s.

SHARE\_CLK can optionally be used to synchronize ON/OFF dependency on  $V_{\text{IN}}$  across multiple chips by setting the Mfr\_config\_all\_vin\_share\_enable bit of the MFR\_CONFIG\_ALL\_LTC2977 register. When configured this way the chip will hold SHARE\_CLK low when the unit is off for insufficient input voltage and upon detecting that SHARE\_CLK is held low the chip will disable all channels after a brief deglitch period. When the SHARE\_CLK pin is allowed to rise, the chip will respond by beginning a soft-start sequence. In this case the slowest  $V_{\text{IN\_ON}}$  detection will take over and synchronize other chips to its soft-start sequence.

## OPERATION

### PMBus SERIAL DIGITAL INTERFACE

The LTC2977 communicates with a host (master) using the standard PMBus serial bus interface. The PMBus Timing Diagram shows the timing relationship of the signals on the bus. The two bus lines, SDA and SCL, must be high when the bus is not in use. External pull-up resistors or current sources are required on these lines.

The LTC2977 is a slave device. The master can communicate with the LTC2977 using the following formats:

- Master transmitter, slave receiver
- Master receiver, slave transmitter

The following SMBus protocols are supported:

- Write Byte, Write Word, Send Byte
- Read Byte, Read Word, Block Read
- Alert Response Address

Figure 1a-12 illustrate the aforementioned SMBus protocols. All transactions support PEC (packet error check) and GCP (group command protocol). The Block Read supports 255 bytes of returned data. For this reason, the PMBus timeout may be extended using the `Mfr_config_all_longer_pmbus_timeout` setting.

The LTC2977 will not acknowledge any PMBus command other than `MFR_COMMON` if it is still busy with a `STORE_USER_ALL`, `RESTORE_USER_ALL`, `MFR_CONFIG_LTC2977` or if fault log data is being written to the EEPROM. `Status_word_busy` will be set when this happens.

### PMBus

PMBus is an industry standard that defines a means of communication with power conversion devices. It is comprised of an industry standard SMBus serial interface and the PMBus command language.

The PMBus two wire interface is an incremental extension of the SMBus. SMBus is built upon I<sup>2</sup>C with some minor differences in timing, DC parameters and protocol. The SMBus protocols are more robust than simple I<sup>2</sup>C byte commands because they provide timeouts to prevent bus hangs and optional packet error checking (PEC) to ensure data integrity. In general, a master device that can be configured for I<sup>2</sup>C communication can be used for PMBus communication with little or no change to hardware or firmware.

For a description of the minor extensions and exceptions PMBus makes to SMBus, refer to PMBus Specification Part 1 Revision 1.1: paragraph 5: Transport. This can be found at:

[www.pmbus.org](http://www.pmbus.org).

For a description of the differences between SMBus and I<sup>2</sup>C, refer to system management bus (SMBus) specification version 2.0: Appendix B – Differences Between SMBus and I<sup>2</sup>C. This can be found at:

[www.smbus.org](http://www.smbus.org).

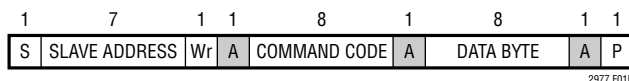
When using an I<sup>2</sup>C controller to communicate with a PMBus part it is important that the controller be able to write a byte of data without generating a stop. This will allow the controller to properly form the repeated start of the PMBus read command by concatenating a start command byte write with an I<sup>2</sup>C read.

# OPERATION

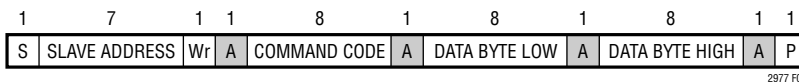
- S START CONDITION
- Sr REPEATED START CONDITION
- Rd READ (BIT VALUE OF 1)
- Wr WRITE (BIT VALUE OF 0)
- $\bar{A}$  NOT ACKNOWLEDGE (HIGH)
- A ACKNOWLEDGE (LOW)
- P STOP CONDITION
- PEC PACKET ERROR CODE
- MASTER TO SLAVE
- SLAVE TO MASTER
- ... CONTINUATION OF PROTOCOL

2977 F01a

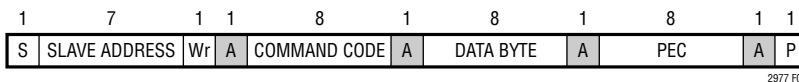
**Figure 1a. PMBus Packet Protocol Diagram Element Key**



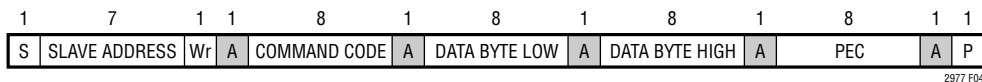
**Figure 1b. Write Byte Protocol**



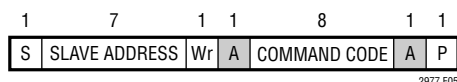
**Figure 2. Write Word Protocol**



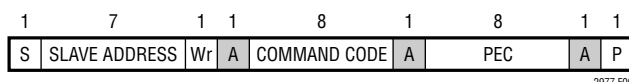
**Figure 3. Write Byte Protocol with PEC**



**Figure 4. Write Word Protocol with PEC**

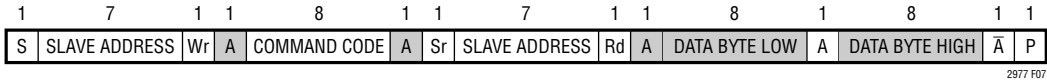


**Figure 5. Send Byte Protocol**

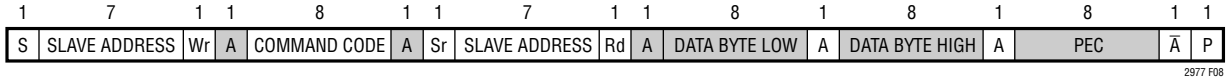


**Figure 6. Send Byte Protocol with PEC**

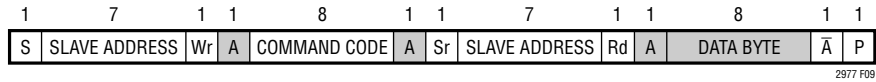
**OPERATION**



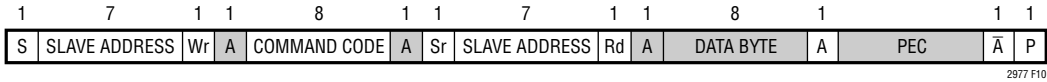
**Figure 7. Read Word Protocol**



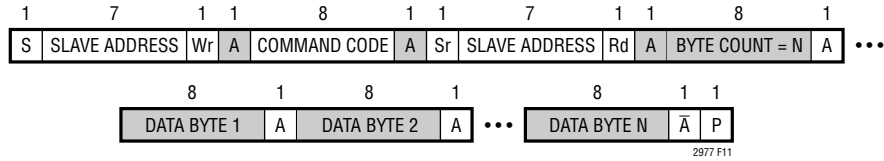
**Figure 8. Read Word Protocol with PEC**



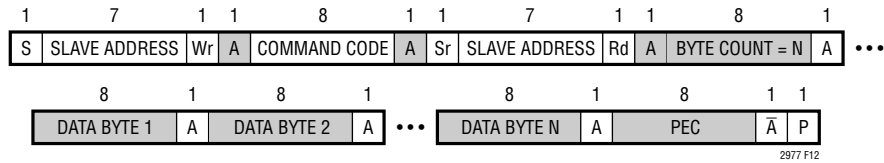
**Figure 9. Read Byte Protocol**



**Figure 10. Read Byte Protocol with PEC**



**Figure 11. Block Read**



**Figure 12. Block Read with PEC**

## OPERATION

### Device Address

The I<sup>2</sup>C/SMBus address of the LTC2977 equals the base address + N where N is a number from 0 to 8. N can be configured by setting the ASEL0 and ASEL1 pins to V<sub>DD33</sub>, GND or FLOAT. See Table 1. Using one base address and the nine values of N, nine LTC2977s can be connected together to control 72 outputs. The base address is stored in the MFR\_I2C\_BASE\_ADDRESS register. The base address can be written to any value, but generally should

not be changed unless the desired range of addresses overlap existing addresses. Watch that the address range does not overlap with other I<sup>2</sup>C/SMBus device or global addresses, including I<sup>2</sup>C/SMBus multiplexers and bus buffers. This will bring you great happiness.

**Table 1. LTC2977 Address Look-Up Table with MFR\_I2C\_BASE\_ADDRESS Set to 7-Bit 0x5C**

ADDRESS PINS		DESCRIPTION	HEX DEVICE ADDRESS		BINARY DEVICE ADDRESS BITS							
ASEL1	ASEL0		7-Bit	8-Bit	6	5	4	3	2	1	0	R/W
X	X	Alert Response	0C	19	0	0	0	1	1	0	0	1
X	X	Global	5B	B6	1	0	1	1	0	1	1	0
L	L	N = 0	5C*	B8	1	0	1	1	1	0	0	0
L	NC	N = 1	5D	BA	1	0	1	1	1	0	1	0
L	H	N = 2	5E	BC	1	0	1	1	1	1	0	0
NC	L	N = 3	5F	BE	1	0	1	1	1	1	1	0
NC	NC	N = 4	60	C0	1	1	0	0	0	0	0	0
NC	H	N = 5	61	C2	1	1	0	0	0	0	1	0
H	L	N = 6	62	C4	1	1	0	0	0	1	0	0
H	NC	N = 7	63	C6	1	1	0	0	0	1	1	0
H	H	N = 8	64	C8	1	1	0	0	1	0	0	0

H = Tie to V<sub>DD33</sub>, NC = No Connect = Open or Float, L = Tie to GND, X = Don't Care

\*MFR\_I2C\_BASE\_ADDRESS = 7bit 0x5C (Factory Default)

## OPERATION

The LTC2977 always responds to its global address and the SMBus Alert Response address regardless of the state of its ASEL pins and the MFR\_I2C\_BASE\_ADDRESS register.

### Processing Commands

The LTC2977 uses a dedicated processing block to ensure quick response to all of its commands. There are a few exceptions where the part will NACK a subsequent command because it is still processing the previous command. These are summarized in the following tables. MFR\_COMMON is a special command that may always be read even when the part is busy. This provides an alternate method for a host to determine if the LTC2977 is busy.

If a part is busy processing a previous command and a new command arrives, a BUSY fault is created. The ALERTB is pulled low and the second command is not processed. To avoid the occurrence of a BUSY fault, the user can add a polling loop to SEND BYTE, WRITE BYTE, and WRITE WORD commands. A polling loop checks whether the device is busy and the master issues a subsequent command only if the device is not busy. The master performs this check by reading bit 6 in the MFR\_COMMON command. Bit 6 is low when the LTC2977 is busy. EEPROM commands are in Table 2 below, which includes typical execution delays.

**Table 2. EEPROM Related Commands**

COMMAND	TYPICAL DELAY*	COMMENT
STORE_USER_ALL	$t_{\text{MASS\_WRITE}}$	These commands have large delays and require monitoring of MFR_COMMON bit 6. If MFR_COMMON bit 6 is low, the LTC2977 will not accept new commands (except MFR_COMMON) and will be in a busy state. If another command is issued while the device is busy, the address byte will be ACKed, the command byte will be NACKed, and ALERTB will be asserted low. MFR_COMMON may always be read without creating a BUSY fault.
RESTORE_USER_ALL	30ms	
MFR_FAULT_LOG_CLEAR	175ms	
MFR_FAULT_LOG_STORE	20ms	
Internal Fault Log	20ms	
MFR_FAULT_LOG_RESTORE	2ms	
MFR_EE_ERASE	Consult Factory	
MFR_EE_DATA	Consult Factory	

\* The typical delay indicates the typical amount of time needed to complete the internal operation. It is measured from the stop of the first command to the start of the next command.

Writes to RAM locations may also cause BUSY faults. Table 2 shows typical delays for commands that may require time to complete the internal operation.

**Table 3. Other Commands**

COMMAND	TYPICAL DELAY*	COMMENT
MFR_CONFIG	<50 $\mu$ s	The LTC2975 will not accept new commands (except MFR_COMMON) while it is processing this command and will be in a busy state. If another command is issued while the device is busy, the address byte will be ACKed, the command byte will be NACKed, and ALERTB will be asserted low. MFR_COMMON may always be read without creating a BUSY fault.
TON_RISE	<50 $\mu$ s	
VOUT_OV_FAULT_LIMIT	<50 $\mu$ s	
VOUT_UV_FAULT_LIMIT	<50 $\mu$ s	
MFR_DAC	<50 $\mu$ s	
MFR_CONFIG	<50 $\mu$ s	

\* The typical delay indicates the typical amount of time needed to complete the internal operation. It is measured from the stop of the first command to the start of the next command.

### Other PMBus Timing Notes

COMMAND	COMMENT
CLEAR_FAULTS	The LTC2977 will accept commands while it is completing this command but the affected status flags will not be cleared for up to 500 $\mu$ s.

## PMBus COMMAND SUMMARY

Summary Table

COMMAND NAME	CMD CODE	DESCRIPTION	TYPE	PAGED	DATA FORMAT	UNITS	EEPROM	DEFAULT VALUE	REF PAGE
PAGE	0x00	Channel or page currently selected for any command that supports paging.	R/W Byte	N	Reg			0x00	28
OPERATION	0x01	Operating mode control. On/Off, Margin High and Margin Low.	R/W Byte	Y	Reg		Y	0x00	33
ON_OFF_CONFIG	0x02	CONTROL pin & PMBus bus on/off command setting.	R/W Byte	Y	Reg		Y	0x1E	34
CLEAR_FAULTS	0x03	Clear any fault bits that have been set.	Send Byte	Y				NA	34
WRITE_PROTECT	0x10	Level of protection provided by the device against accidental changes.	R/W Byte	N	Reg		Y	0x00	28
STORE_USER_ALL	0x15	Store entire operating memory to EEPROM.	Send Byte	N				NA	35
RESTORE_USER_ALL	0x16	Restore entire operating memory from EEPROM.	Send Byte	N				NA	35
CAPABILITY	0x19	Summary of PMBus optional communication protocols supported by this device.	R Byte	N	Reg			0xB0	35
VOUT_MODE	0x20	Output voltage data format and mantissa exponent. ( $2^{-13}$ )	R Byte	Y	Reg			0x13	35
VOUT_COMMAND	0x21	Servo Target. Nominal DC/DC converter output voltage setpoint.	R/W Word	Y	L16	V	Y	1.0 0x2000	36
VOUT_MAX	0x24	Upper limit on the output voltage the unit can command regardless of any other commands.	R/W Word	Y	L16	V	Y	4.0 0x8000	36
VOUT_MARGIN_HIGH	0x25	Margin high DC/DC converter output voltage setting.	R/W Word	Y	L16	V	Y	1.05 0x219A	36
VOUT_MARGIN_LOW	0x26	Margin low DC/DC converter output voltage setting.	R/W Word	Y	L16	V	Y	0.95 0x1E66	36
VIN_ON	0x35	Input voltage ( $V_{IN\_SNS}$ ) above which power conversion can be enabled.	R/W Word	N	L11	V	Y	10.0 0xD280	36
VIN_OFF	0x36	Input voltage ( $V_{IN\_SNS}$ ) below which power conversion is disabled. All $V_{OUT\_ENn}$ pins go off immediately.	R/W Word	N	L11	V	Y	9.0 0xD240	36
VOUT_OV_FAULT_LIMIT	0x40	Output overvoltage fault limit	R/W Word	Y	L16	V	Y	1.1 0x2333	36
VOUT_OV_FAULT_RESPONSE	0x41	Action to be taken by the device when an output overvoltage fault is detected.	R/W Byte	Y	Reg		Y	0x80	38
VOUT_OV_WARN_LIMIT	0x42	Output overvoltage warning limit .	R/W Word	Y	L16	V	Y	1.075 0x2266	36
VOUT_UV_WARN_LIMIT	0x43	Output undervoltage warning limit	R/W Word	Y	L16	V	Y	0.925 0x1D9A	36
VOUT_UV_FAULT_LIMIT	0x44	Output undervoltage fault limit. Limit used to determine if TON_MAX_FAULT has been met and the unit is on.	R/W Word	Y	L16	V	Y	0.9 0x1CCD	36
VOUT_UV_FAULT_RESPONSE	0x45	Action to be taken by the device when an output undervoltage fault is detected.	R/W Byte	Y	Reg		Y	0x7F	38
OT_FAULT_LIMIT	0x4F	Overtemperature fault limit.	R/W Word	N	L11	°C	Y	105.0 0xEB48	37
OT_FAULT_RESPONSE	0x50	Action to be taken by the device when an overtemperature fault is detected.	R/W Byte	N	Reg		Y	0xB8	39

Rev. G

## PMBus COMMAND SUMMARY

Summary Table

COMMAND NAME	CMD CODE	DESCRIPTION	TYPE	PAGED	DATA FORMAT	UNITS	EEPROM	DEFAULT VALUE	REF PAGE
OT_WARN_LIMIT	0x51	Overtemperature warning limit.	R/W Word	N	L11	°C	Y	70.0 0xEA30	37
UT_WARN_LIMIT	0x52	Undertemperature warning limit.	R/W Word	N	L11	°C	Y	0 0x8000	37
UT_FAULT_LIMIT	0x53	Undertemperature fault limit.	R/W Word	N	L11	°C	Y	-40.0 0xE580	37
UT_FAULT_RESPONSE	0x54	Action to be taken by the device when an undertemperature fault is detected.	R/W Byte	N	Reg		Y	0xB8	39
VIN_OV_FAULT_LIMIT	0x55	Input overvoltage fault limit measured at V <sub>IN_SNS</sub> pin	R/W Word	N	L11	V	Y	15.0 0xD3C0	36
VIN_OV_FAULT_RESPONSE	0x56	Action to be taken by the device when an input overvoltage fault is detected.	R/W Byte	N	Reg		Y	0x80	39
VIN_OV_WARN_LIMIT	0x57	Input overvoltage warning limit measured at V <sub>IN_SNS</sub> pin	R/W Word	N	L11	V	Y	14.0 0xD380	36
VIN_UV_WARN_LIMIT	0x58	Input undervoltage warning limit measured at V <sub>IN_SNS</sub> pin.	R/W Word	N	L11	V	Y	0 0x8000	36
VIN_UV_FAULT_LIMIT	0x59	Input undervoltage fault limit measured at V <sub>IN_SNS</sub> pin	R/W Word	N	L11	V	Y	0 0x8000	36
VIN_UV_FAULT_RESPONSE	0x5A	Action to be taken by the device when an input undervoltage fault is detected.	R/W Byte	N	Reg		Y	0x00	39
POWER_GOOD_ON	0x5E	Output voltage at or above which a power good should be asserted.	R/W Word	Y	L16	V	Y	0.96 0x1EB8	36
POWER_GOOD_OFF	0x5F	Output voltage at or below which a power good should be deasserted.	R/W Word	Y	L16	V	Y	0.94 0x1E14	36
TON_DELAY	0x60	Time from CONTROL pin and/or OPERATION command = ON to V <sub>OUT_ENn</sub> pin = ON.	R/W Word	Y	L11	ms	Y	1.0 0xBA00	37
TON_RISE	0x61	Time from when the V <sub>OUT_ENn</sub> pin goes high until the LTC2977 optionally soft-connects its DAC and begins to servo the output voltage to the desired value.	R/W Word	Y	L11	ms	Y	10.0 0xD280	37
TON_MAX_FAULT_LIMIT	0x62	Maximum time from V <sub>OUT_ENn</sub> = ON assertion that an UV condition will be tolerated before a TON_MAX_FAULT condition results.	R/W Word	Y	L11	ms	Y	15.0 0xD3C0	37
TON_MAX_FAULT_RESPONSE	0x63	Action to be taken by the device when a TON_MAX_FAULT event is detected.	R/W Byte	Y	Reg		Y	0xB8	40
TOFF_DELAY	0x64	Time from CONTROL pin and/or OPERATION command = OFF to V <sub>OUT_ENn</sub> pin = OFF.	R/W Word	Y	L11	ms	Y	1.0 0xBA00	37
STATUS_BYTE	0x78	One byte summary of the unit's fault condition.	R Byte	Y	Reg			NA	41
STATUS_WORD	0x79	Two byte summary of the unit's fault condition.	R Word	Y	Reg			NA	41
STATUS_VOUT	0x7A	Output voltage fault and warning status.	R Byte	Y	Reg			NA	42
STATUS_INPUT	0x7C	Input voltage fault and warning status measured at V <sub>IN_SNS</sub> pin.	R Byte	N	Reg			NA	42
STATUS_TEMPERATURE	0x7D	Temperature fault and warning status for READ_TEMPERATURE_1.	R Byte	N	Reg			NA	42

## PMBus COMMAND SUMMARY

Summary Table

COMMAND NAME	CMD CODE	DESCRIPTION	TYPE	PAGED	DATA FORMAT	UNITS	EEPROM	DEFAULT VALUE	REF PAGE
STATUS_CML	0x7E	Communication and memory fault and warning status.	R Byte	N	Reg			NA	43
STATUS_MFR_SPECIFIC	0x80	Manufacturer specific fault and state information.	R Byte	Y	Reg			NA	43
READ_VIN	0x88	Input voltage measured at VIN_SNS pin.	R Word	N	L11	V		NA	44
READ_VOUT	0x8B	DC/DC converter output voltage.	R Word	Y	L16	V		NA	44
READ_TEMPERATURE_1	0x8D	Internal junction temperature.	R Word	N	L11	°C		NA	44
PMBUS_REVISION	0x98	PMBus revision supported by this device. Current revision is 1.1.	R Byte	N	Reg			0x11	44
USER_DATA_00	0xB0	Manufacturer reserved for LTpowerPlay™.	R/W Word	N	Reg		Y	NA	60
USER_DATA_01	0xB1	Manufacturer reserved for LTpowerPlay.	R/W Word	Y	Reg		Y	NA	60
USER_DATA_02	0xB2	OEM reserved.	R/W Word	N	Reg		Y	NA	60
USER_DATA_03	0xB3	Scratchpad location.	R/W Word	Y	Reg		Y	0x00	60
USER_DATA_04	0xB4	Scratchpad location.	R/W Word	N	Reg		Y	0x00	60
MFR_LTC_RESERVED_1	0xB5	Manufacturer reserved.	R/W Word	Y	Reg		Y	NA	60
MFR_INFO	0xB6	Manufacturer specific information.	R Word	N	Reg			NA	58
MFR_STATUS_2	0xB7	Additional manufacturer specific fault and state information.	R Word	Y	Reg			NA	61
MFR_LTC_RESERVED_2	0xBC	Manufacturer reserved.	R/W Word	Y	Reg			NA	60
MFR_EE_UNLOCK	0xBD	Unlock user EEPROM for access by MFR_EE_ERASE and MFR_EE_DATA commands.	R/W Byte	N	Reg			NA	64
MFR_EE_ERASE	0xBE	Initialize user EEPROM for bulk programming by MFR_EE_DATA.	R/W Byte	N	Reg			NA	64
MFR_EE_DATA	0xBF	Data transferred to and from EEPROM using sequential PMBus word reads or writes. Supports bulk programming.	R/W Word	N	Reg			NA	64
MFR_COMMAND_PLUS	0xC0	Alternate access to block read and other data: commands for all hosts.	R/W Word	N	Reg			NA	30
MFR_DATA_PLUS0	0xC1	Alternate access to block read and other data: data for alternate host 0.	R/W Word	N	Reg			NA	30
MFR_DATA_PLUS1	0xC2	Alternate access to block read and other data: data for alternate host 1.	R/W Word	N	Reg			NA	30
MFR_TELEMETRY	0xCF	Telemetry data for all output channels.	R Block	N	Reg			NA	62
MFR_CONFIG_LTC2977	0xD0	Configuration bits that are channel specific.	R/W Word	Y	Reg		Y	0x0080	45
MFR_CONFIG_ALL_LTC2977	0xD1	Configuration bits that are common to all pages.	R/W Word	N	Reg		Y	0x1C7B	49
MFR_FAULTBz0_PROPAGATE	0xD2	Configuration that determines if a channel's faulted off state is propagated to the FAULTB00 and FAULTB10 pins.	R/W Byte	Y	Reg		Y	0x00	50
MFR_FAULTBz1_PROPAGATE	0xD3	Manufacturer configuration that Configuration that determines if a channel's faulted off state is propagated to the FAULTB01 and FAULTB11 pins.	R/W Byte	Y	Reg		Y	0x00	50
MFR_PWRGD_EN	0xD4	Configuration for mapping PWRGD and WDI/RESETB status to the PWRGD pin.	R/W Word	N	Reg		Y	0x0000	51

## PMBus COMMAND SUMMARY

**Summary Table**

COMMAND NAME	CMD CODE	DESCRIPTION	TYPE	PAGED	DATA FORMAT	UNITS	EEPROM	DEFAULT VALUE	REF PAGE
MFR_FAULTB00_RESPONSE	0xD5	Action to be taken by the device when the FAULTB00 pin is asserted low.	R/W Byte	N	Reg		Y	0x00	52
MFR_FAULTB01_RESPONSE	0xD6	Action to be taken by the device when the FAULTB01 pin is asserted low.	R/W Byte	N	Reg		Y	0x00	52
MFR_FAULTB10_RESPONSE	0xD7	Action to be taken by the device when the FAULTB10 pin is asserted low.	R/W Byte	N	Reg		Y	0x00	52
MFR_FAULTB11_RESPONSE	0xD8	Action to be taken by the device when the FAULTB11 pin is asserted low.	R/W Byte	N	Reg		Y	0x00	52
MFR_VINEN_OV_FAULT_RESPONSE	0xD9	Action to be taken by the $V_{IN\_EN}$ pin in response to a VOUT_OV_FAULT	R/W Byte	N	Reg		Y	0x00	53
MFR_VINEN_UV_FAULT_RESPONSE	0xDA	Action to be taken by the $V_{IN\_EN}$ pin in response to a VOUT_UV_FAULT	R/W Byte	N	Reg		Y	0x00	54
MFR_RETRY_DELAY	0xDB	Retry interval during FAULT retry mode.	R/W Word	N	L11	ms	Y	200.0 0xF320	55
MFR_RESTART_DELAY	0xDC	Delay from actual CONTROL active edge to virtual CONTROL active edge.	R/W Word	N	L11	ms	Y	400.0 0xFB20	55
MFR_VOUT_PEAK	0xDD	Maximum measured value of READ_VOUT.	R Word	Y	L16	V		NA	56
MFR_VIN_PEAK	0xDE	Maximum measured value of READ_VIN.	R Word	N	L11	V		NA	56
MFR_TEMPERATURE_PEAK	0xDF	Maximum measured value of READ_TEMPERATURE_1.	R Word	N	L11	°C		NA	56
MFR_DAC	0xE0	The code of the 10-bit DAC.	R/W Word	Y	Reg			NA	56
MFR_POWERGOOD_ASSERTION_DELAY	0xE1	Power good output assertion delay.	R/W Word	N	L11	ms	Y	100.0 0xEB20	57
MFR_WATCHDOG_T_FIRST	0xE2	First watchdog timer interval.	R/W Word	N	L11	ms	Y	0 0x8000	63
MFR_WATCHDOG_T	0xE3	Watchdog timer interval.	R/W Word	N	L11	ms	Y	0 0x8000	63
MFR_PAGE_FF_MASK	0xE4	Configuration defining which channels respond to global page commands (PAGE=0xFF).	R/W Byte	N	Reg		Y	0xFF	29
MFR_PADS	0xE5	Current state of selected digital I/O pads.	R Word	N	Reg			NA	57
MFR_I2C_BASE_ADDRESS	0xE6	Base value of the I <sup>2</sup> C/SMBus address byte.	R/W Byte	N	Reg		Y	0x5C	30
MFR_SPECIAL_ID	0xE7	Manufacturer code for identifying the LTC2977	R Word	N	Reg		Y	0x0131	58
MFR_SPECIAL_LOT	0xE8	Customer dependent codes that identify the factory programmed user configuration stored in EEPROM. Contact factory for default value.	R Byte	Y	Reg		Y	NA	58
MFR_VOUT_DISCHARGE_THRESHOLD	0xE9	Coefficient used to multiply VOUT_COMMAND in order to determine V <sub>OUT</sub> off threshold voltage.	R/W Word	Y	L11		Y	2.0 0xC200	59
MFR_FAULT_LOG_STORE	0xEA	Command a transfer of the fault log from RAM to EEPROM. This causes the part to behave as if a channel has faulted off.	Send Byte	N				NA	65

## PMBus COMMAND SUMMARY

Summary Table

COMMAND NAME	CMD CODE	DESCRIPTION	TYPE	PAGED	DATA FORMAT	UNITS	EEPROM	DEFAULT VALUE	REF PAGE
MFR_FAULT_LOG_RESTORE	0xEB	Command a transfer of the fault log previously stored in EEPROM back to RAM.	Send Byte	N				NA	65
MFR_FAULT_LOG_CLEAR	0xEC	Initialize the EEPROM block reserved for fault logging and clear any previous fault logging locks.	Send Byte	N				NA	66
MFR_FAULT_LOG_STATUS	0xED	Fault logging status.	R Byte	N	Reg		Y	NA	66
MFR_FAULT_LOG	0xEE	Fault log data bytes. This sequentially retrieved data is used to assemble a complete fault log. 256 Bytes: 0xFF followed by 255 bytes of fault log data.	R Block	N	Reg		Y	NA	67
MFR_COMMON	0xEF	Manufacturer status bits that are common across multiple LTC chips.	R Byte	N	Reg			NA	59
MFR_RETRY_COUNT	0xF7	Retry count for all faulted off conditions that enable retry.	R/W Byte	N	Reg		Y	0x07	55
MFR_VOUT_MIN	0xFB	Minimum measured value of READ_VOUT.	R Word	Y	L16	V		NA	60
MFR_VIN_MIN	0xFC	Minimum measured value of READ_VIN.	R Word	N	L11	V		NA	60
MFR_TEMPERATURE_MIN	0xFD	Minimum measured value of READ_TEMPERATURE_1.	R Word	N	L11	°C		NA	61

### Data Formats

L11	Linear_5s_11s	<p>PMBus data field b[15:0]            Value = <math>Y \cdot 2^N</math>            where <math>N = b[15:11]</math> is a 5-bit two's complement integer and <math>Y = b[10:0]</math> is an 11-bit two's complement integer            Example:            READ_VIN = 10V            For b[15:0] = 0xD280 = 1101_0010_1000_0000b            Value = <math>640 \cdot 2^{-6} = 10</math>            See PMBus Spec Part II: Paragraph 7.1</p>
L16	Linear_16u	<p>PMBus data field b[15:0]            Value = <math>Y \cdot 2^N</math> where <math>Y = b[15:0]</math> is an unsigned integer and <math>N = \text{Vout\_mode\_parameter}</math> is a 5-bit two's complement exponent that is hardwired to -13 decimal.            Example:            VOUT_COMMAND = 4.75V            For b[15:0] = 0x9800 = 1001_1000_0000_0000b            Value = <math>38912 \cdot 2^{-13} = 4.75</math>            See PMBus Spec Part II: Paragraph 8.3.1</p>
Reg	Register	<p>PMBus data field b[15:0] or b[7:0].            Bit field meaning is defined in detailed PMBus Command Register Description.</p>

## PMBus COMMAND DESCRIPTION

### ADDRESSING AND WRITE PROTECT

#### PAGE

The LTC2977 has eight pages that correspond to the eight DC/DC converter channels that can be managed. Each DC/DC converter channel can be uniquely programmed by first setting the appropriate page.

Setting PAGE = 0xFF allows a simultaneous write to all pages for PMBus commands that support global page programming. The only commands that support PAGE = 0xFF are CLEAR\_FAULTS, OPERATION and ON\_OFF\_CONFIG. See MFR\_PAGE\_FF\_MASK for additional options. Reading any paged PMBus register with PAGE = 0xFF returns unpredictable data and will trigger a CML fault. Writes to commands that do not support PAGE = 0xFF with PAGE = 0xFF will be ignored and generate a CML fault.

#### PAGE Data Contents

BIT(S)	SYMBOL	PURPOSE
b[7:0]	Page	Page operation. 0x00: All PMBus commands address channel/page 0. 0x01: All PMBus commands address channel/page 1. • • • 0x07: All PMBus commands address channel/page 7. 0xFF: All nonspecified values reserved. 0xFF: A single PMBus write/send to commands that support this mode will simultaneously address all channels/pages with MFR_PAGE_FF_MASK enabled.

#### WRITE\_PROTECT

The WRITE\_PROTECT command provides protection against accidental programming of the LTC2977 command registers. All supported commands may have their parameters read, regardless of the WRITE\_PROTECT setting, and the EEPROM contents can also be read regardless of the WRITE\_PROTECT settings.

There are two levels of write protection:

- Level 1: Nothing can be changed except the level of write protection itself. Values can be read from all pages. This setting can be stored to EEPROM.
- Level 2: Nothing can be changed except for the level of protection, channel on/off state and clearing of faults. Values can be read from all pages. This setting can be stored to EEPROM.

#### WRITE\_PROTECT Data Contents

BITS(S)	SYMBOL	OPERATION
b[7:0]	Write_protect[7:0]	1000_0000b: Level 1 Protection - Disable all writes except to the WRITE_PROTECT, PAGE, MFR_EE_UNLOCK, and STORE_USER_ALL commands. 0100_0000b: Level 2 Protection – Disable all writes except to the WRITE_PROTECT, PAGE, MFR_EE_UNLOCK, STORE_USER_ALL, OPERATION, MFR_COMMAND_PLUS, MFR_PAGE_FF_MASK and CLEAR_FAULTS commands. 0000_0000b: Enable writes to all commands. xxxx_xxxx: All other values reserved.

## PMBus COMMAND DESCRIPTION

### WRITE PROTECT Pin

The WP pin allows the user to write-protect the LTC2977's configuration registers. The WP pin is active high, and when asserted it provides Level 2 protection: all writes are disabled except to the WRITE\_PROTECT, PAGE, MFR\_EE\_UNLOCK, STORE\_USER\_ALL, OPERATION, MFR\_COMMAND\_PLUS, MFR\_PAGE\_FF\_MASK and CLEAR\_FAULTS commands. The most restrictive setting between the WP pin and WRITE\_PROTECT command will override.

WP PIN STATE	WRITE_PROTECT COMMAND VALUE	WRITE PROTECT LEVEL
Low	0x00	No write protection
	0x40	Level 2
	0x80	Level 1
High	0x00	Level 2
	0x40	Level 2
	0x80	Level 1

### MFR\_PAGE\_FF\_MASK

The MFR\_PAGE\_FF\_MASK command is used to select which channels respond when the global page command (PAGE=0xFF) is in use.

#### MFR\_PAGE\_FF\_MASK Data Contents

BIT(S)	SYMBOL	OPERATION
b[7]	Mfr_page_ff_mask_chan7	Channel 7 masking of global page command (PAGE=0xFF) accesses 0 = ignore global page command accesses 1 = fully respond to global page command accesses
b[6]	Mfr_page_ff_mask_chan6	Channel 6 masking of global page command (PAGE=0xFF) accesses 0 = ignore global page command accesses 1 = fully respond to global page command accesses
b[5]	Mfr_page_ff_mask_chan5	Channel 5 masking of global page command (PAGE=0xFF) accesses 0 = ignore global page command accesses 1 = fully respond to global page command accesses
b[4]	Mfr_page_ff_mask_chan4	Channel 4 masking of global page command (PAGE=0xFF) accesses 0 = ignore global page command accesses 1 = fully respond to global page command accesses
b[3]	Mfr_page_ff_mask_chan3	Channel 3 masking of global page command (PAGE=0xFF) accesses 0 = ignore global page command accesses 1 = fully respond to global page command accesses
b[2]	Mfr_page_ff_mask_chan2	Channel 2 masking of global page command (PAGE=0xFF) accesses 0 = ignore global page command accesses 1 = fully respond to global page command accesses
b[1]	Mfr_page_ff_mask_chan1	Channel 1 masking of global page command (PAGE=0xFF) accesses 0 = ignore global page command accesses 1 = fully respond to global page command accesses
b[0]	Mfr_page_ff_mask_chan0	Channel 0 masking of global page command (PAGE=0xFF) accesses 0 = ignore global page command accesses 1 = fully respond to global page command accesses

## PMBus COMMAND DESCRIPTION

### MFR\_I2C\_BASE\_ADDRESS

The MFR\_I2C\_BASE\_ADDRESS command determines the base value for the I<sup>2</sup>C/SMBus address byte. Offsets of 0 to 8 are added to this base address to make the device I<sup>2</sup>C/SMBus address. The part responds to the device address. For example, with the factory default MFR\_I2C\_BASE\_ADDRESS of 0x5C, with both ASEL1 and ASEL0 High (Offset N=8), the device address would be 0x5C + 8 = 0x64.

#### MFR\_I2C\_BASE\_ADDRESS Data Contents

BIT(S)	SYMBOL	OPERATION
b[7]	Reserved	Read only, always returns 0.
b[6:0]	i2c_base_address	This 7-bit value determines the base value of the 7-bit I <sup>2</sup> C/SMBus address. See Operation Section: Device Address.

### MFR\_COMMAND\_PLUS, MFR\_DATA\_PLUS0, MFR\_DATA\_PLUS1, MFR\_STATUS\_PLUS0, and MFR\_STATUS\_PLUS1

Similar to the PAGE register, these registers allow the user to indirectly address memory. These registers are useful to advanced users for reading or writing memory as described below.

Command Plus operations use a sequence of word commands to support the following:

- An alternate method for reading block data using sequential standard word reads.
- A peek operation that allows up to two additional hosts to read an internal register using PMBus word protocol where each host has a unique page.
- A poke operation that allows up to two additional hosts to write an internal register using PMBus word protocol where each host has a unique page.
- Peek, Poke and Command Plus block reads do not interfere with normal PMBus accesses or page values set by PAGE. This enables multi master support for up to 3 hosts.

#### MFR\_COMMAND\_PLUS Data Contents

BIT(S)	SYMBOL	OPERATION
b[15]	Mfr_command_plus_reserved	Reserved. Always returns 0.
b[14]	Mfr_command_plus_id	Command Plus host ID 0: Mfr_command_plus pointer and page are cached and used for all Mfr_data_plus0 accesses. 1: Mfr_command_plus pointer and page are cached and used for all Mfr_data_plus1 accesses.
b[13:9]	Mfr_command_plus_page	Page to be used when peeking or poking via Mfr_data_plus0 or Mfr_data_plus1. Allowed values are 0 through 7. This page value is cached separately for Mfr_data_plus0 and Mfr_data_plus1 based on the value of Mfr_command_plus_id when this register is written.
b[8:0]	Mfr_command_plus_pointer	Internal memory location accessed by Mfr_data_plus0 or Mfr_data_plus1. Mfr_data_plus0 and Mfr_data_plus1 pointers are cached separately. Legal values are listed in the Cmd Code column of the PMBus Command Summary table. All other values are reserved, except for the special poke enable/disable values listed in Enabling and Disabling Poke Operations on page 32, and the command values listed below for Mfr_status_plus0 and Mfr_status_plus1.

## PMBus COMMAND DESCRIPTION

### MFR\_DATA\_PLUS0 and MFR\_DATA\_PLUS1 Data Contents

BIT(S)	SYMBOL	OPERATION
b[15:0]	Mfr_data_plus0 Mfr_data_plus1	A read from this register returns data referenced by the last matching Mfr_command_plus write. More specifically, writes to Mfr_command_plus by host 0 update Mfr_data_plus0, and writes to Mfr_command_plus by host1 update Mfr_data_plus1. Multiple sequential reads while pointer=MFR_FAULT_LOG return the complete contents of the block read buffer. Block reads beyond the end of the buffer return zeros.  A write to this register will transfer the data to the location referenced by the last matching Mfr_command_plus_pointer when the Poke operation protocol described in Poke Operation Using Mfr_data_plus0 on page 32 is followed.

### MFR\_STATUS\_PLUS0 and MFR\_STATUS\_PLUS1 Data Contents

BIT(S)	SYMBOL	OPERATION
b[7:2]	Reserved	
b[1]	Mfr_status_plus_poke_failed0 Mfr_status_plus_poke_failed1	Status of most recent poke for matching host. 0: Last poke operation did not fail. 1: Last poke operation failed because pokes were not enabled, as described in Enabling and Disabling Poke Operations below, or an illegal Mfr_command_plus_page value was used.
b[0]	Mfr_status_plus_block_peek_failed0 Mfr_status_plus_block_peek_failed1	Status of most recent block peek for matching host. 0: Last block peek was not aborted. 1: Last block peek was aborted due to an intervening fault log EEPROM write, MFR_FAULT_LOG_STORE command, or standard PMBus block read of MFR_FAULT_LOG. The intervening operation is always completed cleanly.

MFR\_STATUS\_PLUS0 is at command location 0x2C, and MFR\_STATUS\_PLUS1 is at command location 0x2D. These correspond to reserved PMBus command locations. These two status registers can only be read via Command Plus peeks.

### Reading Fault Log Using Command Plus and Mfr\_data\_plus0

Write Mfr\_command\_plus\_pointer=0xEE with Mfr\_command\_plus\_page=0 and Mfr\_command\_plus\_id=0.

Read data from Mfr\_data\_plus0; each read returns the next data word of the MFR\_FAULT\_LOG command:

- The first word read is Byte\_count[15:0]=0x00FF.
- The next set of words read is the Preamble with 2 bytes packed into a word. Refer to Fault Log section for details.
- The next set of words read is the Cyclical Loop Data with 2 bytes per word. Refer to Fault Log section for details.
- Extra reads return zero.
- Interleaved PMBus word and byte commands do not interfere with an ongoing Command Plus block read.
- Interleaved PMBus block reads of MFR\_FAULT\_LOG will interrupt this command.

Check status to be sure the data just read was all valid:

- Write Mfr\_command\_plus\_pointer=0x2C with Mfr\_command\_plus\_page=0 and Mfr\_command\_plus\_id=0.
- Read data from Mfr\_data\_plus0 and confirm that Mfr\_status\_plus\_block\_peek\_failed0 = 0.

## PMBus COMMAND DESCRIPTION

### Peek Operation using Mfr\_data\_plus0

Internal words and bytes may be read using Command Plus:

Write Mfr\_command\_plus\_pointer=CMD\_CODE with Mfr\_command\_plus\_page=page and Mfr\_command\_plus\_id=0.

The CMD\_CODE's are listed in the PMBus Command Summary table.

Read data from Mfr\_data\_plus0. Data is always read using a word read. Byte data is returned with the upper byte set to 0.

### Enabling and Disabling Poke Operations

Poke operations to Mfr\_data\_plus0 are enabled by writing Mfr\_command\_plus = 0x0BF6.

Poke operations to Mfr\_data\_plus0 are disabled by writing Mfr\_command\_plus = 0x01F6.

Poke operations to Mfr\_data\_plus1 are enabled by writing Mfr\_command\_plus = 0x4BF6.

Poke operations to Mfr\_data\_plus1 are disabled by writing Mfr\_command\_plus = 0x41F6.

### Poke Operation Using Mfr\_data\_plus0

Internal words and bytes may be written using Command Plus:

Enable poke access for Mfr\_data\_plus0. This need only be done once after a power-up or WDI reset.

Write Mfr\_command\_plus\_pointer=CMD\_CODE with Mfr\_command\_plus\_page=page and Mfr\_command\_plus\_id=0.

The CMD\_CODE's are listed in the PMBus Command Summary table.

Write the new data value to Mfr\_data\_plus0

Optionally check status to be sure data was written as desired:

- Write Mfr\_command\_plus\_pointer=0x2C with Mfr\_command\_plus\_page=0 and Mfr\_command\_plus\_id=0.
- Read data from Mfr\_data\_plus0 and confirm that Mfr\_status\_plus\_poke\_failed0 = 0.

### Command Plus Operations Using Mfr\_data\_plus1

All the previous operations may be accessed via Mfr\_data\_plus1 by substituting Mfr\_command\_plus\_id value with a 1. Poke operations must be enabled for Mfr\_data\_plus1.

## PMBus COMMAND DESCRIPTION

### OPERATION, MODE AND EEPROM COMMANDS

#### OPERATION

The OPERATION command is used to turn the unit on and off in conjunction with the CONTROL $n$  pin and ON\_OFF\_CONFIG. This command register responds to the global page command (PAGE=0xFF). The contents and functions of the data byte are shown in the following tables. A minimum  $t_{OFF\_MIN}$  wait time must be observed between OPERATION commands used to turn the unit off and then back on.

#### OPERATION Data Contents (On\_off\_config\_use\_pmbus=1)

SYMBOL	Action	Operation_control[1:0]	Operation_margin[1:0]	Operation_fault[1:0]	Reserved (read only)
BITS		b[7:6]	b[5:4]	b[3:2]	b[1:0]
FUNCTION	Turn off immediately	00	XX	XX	00
	Turn on	10	00	XX	00
	Margin Low (Ignore Faults and Warnings)	10	01	01	00
	Margin Low	10	01	10	00
	Margin High (Ignore Faults and Warnings)	10	10	01	00
	Margin High	10	10	10	00
	Sequence off and margin to nominal	01	00	XX	00
	Sequence off and Margin Low (Ignore Faults and Warnings)	01	01	01	00
	Sequence off and Margin Low	01	01	10	00
	Sequence off and Margin High (Ignore Faults and Warnings)	01	10	01	00
	Sequence off and Margin High	01	10	10	00
Reserved	All remaining combinations				

#### OPERATION Data Contents (On\_off\_config\_use\_pmbus=0)

SYMBOL	Action	Operation_control[1:0]	Operation_margin[1:0]	Operation_fault[1:0]	Reserved (read only)
BITS		b[7:6]	b[5:4]	b[3:2]	b[1:0]
FUNCTION	Output at Nominal	00, 01 or 10	00	XX	00
	Margin Low (Ignore faults and Warnings)	00, 01 or 10	01	01	00
	Margin Low	00, 01 or 10	01	10	00
	Margin High (Ignore Faults and Warnings)	00, 01 or 10	10	01	00
	Margin High	00, 01 or 10	10	10	00
	Reserved	All remaining combinations			

## PMBus COMMAND DESCRIPTION

### ON\_OFF\_CONFIG

The ON\_OFF\_CONFIG command configures the combination of CONTROL $n$  pin input and PMBus bus commands needed to turn the LTC2977 on/off, including the power-on behavior, as shown in the following table. This command register responds to the global page command (PAGE=0xFF). After the part has initialized, an additional comparator monitors VIN\_SNS. The VIN\_ON threshold must be exceeded before the output power sequencing can begin. After V<sub>IN</sub> is initially applied, the part will typically require t<sub>INIT</sub> time to initialize and begin the TON\_DELAY timer. The readback of voltages and currents may require an additional wait for t<sub>UPDATE\_ADC</sub>. A minimum t<sub>OFF\_MIN</sub> wait time must be observed for any CONTROL pin toggle used to turn the unit off and then back on.

#### ON\_OFF\_CONFIG Data Contents

BITS(S)	SYMBOL	OPERATION
b[7:5]	Reserved	Don't care. Always returns 0.
b[4]	On_off_config_controlled_on	Controls default autonomous power-up operation. 0: Unit powers up regardless of the CONTROL $n$ pin or OPERATION value. Unit always powers up with sequencing. To turn unit on without sequencing, set TON_DELAY = 0. 1: Unit does not power up unless commanded by the CONTROL $n$ pin and/or the OPERATION command on the serial bus. If On_off_config[3:2] = 00, the unit never powers up.
b[3]	On_off_config_use_pmbus	Controls how the unit responds to commands received via the serial bus. 0: Unit ignores the Operation_control[1:0] bits. 1: Unit responds to Operation_control[1:0]. Depending on On_off_config_use_control, the unit may also require the CONTROL $n$ pin to be asserted for the unit to start.
b[2]	On_off_config_use_control	Controls how unit responds to the CONTROL $n$ pin. 0: Unit ignores the CONTROL $n$ pin. 1: Unit requires the CONTROL $n$ pin to be asserted to start the unit. Depending on On_off_config_use_pmbus the OPERATION command may also be required to instruct the device to start.
b[1]	Reserved	Not supported. Always returns 1.
b[0]	On_off_config_control_fast_off	CONTROL $n$ pin turn off action when commanding the unit to turn off 0: Use the programmed TOFF_DELAY. 1: Turn off the output and stop transferring energy as quickly as possible, i.e. pull V <sub>OUT_EN<math>n</math></sub> low immediately. The device does not sink current in order to decrease the output voltage fall time.

### CLEAR\_FAULTS

The CLEAR\_FAULTS command is used to clear any status bits that have been set. This command clears all fault and warning bits in all unpagged status registers, and the pagged status registers selected by the current PAGE setting. At the same time, the device negates (clears, releases) its contribution to ALERTB.

The CLEAR\_FAULTS command does not cause a unit that has latched off for a fault condition to restart. See Clearing Latched Faults for more information.

If the fault condition is present after the fault status is cleared, the fault status bit shall be set again and the host notified by the usual means.

Note: This command responds to the global page command (PAGE=0xFF).

## PMBus COMMAND DESCRIPTION

### *STORE\_USER\_ALL and RESTORE\_USER\_ALL*

STORE\_USER\_ALL, RESTORE\_USER\_ALL commands provide access to User EEPROM space. Once a command is stored in User EEPROM, it will be restored with an explicit restore command or when the part emerges from power-on reset after power is applied. While either of these commands is being processed, the device will indicate it is busy, see Response When Part Is Busy on page 67.

STORE\_USER\_ALL. Issuing this command will store all operating memory commands with a corresponding EEPROM memory location.

RESTORE\_USER\_ALL. Issuing this command will restore all commands from EEPROM Memory. It is recommended that this command not be executed while a unit is enabled since all monitoring is suspended while the EEPROM is transferred to operating memory, and intermediate values from EEPROM may not be compatible with the values initially stored in operating memory.

### **CAPABILITY**

The CAPABILITY command provides a way for a host system to determine some key capabilities of the LTC2977. This one byte command is read only.

#### **CAPABILITY Data Contents**

BIT(S)	SYMBOL	OPERATION
b[7]	Capability_pec	Hard coded to 1 indicating Packet Error Checking is supported. Reading the Mfr_config_all_pec_en bit will indicate whether PEC is currently required.
b[6:5]	Capability_scl_max	Hard coded to 01b indicating the maximum supported bus speed is 400kHz.
b[4]	Capability_smb_alert	Hard coded to 1 indicating this device does have an ALERTB pin and does support the SMBus Alert Response Protocol.
b[3:0]	Reserved	Always returns 0.

### **VOUT\_MODE**

This command is read only and specifies the mode and exponent for all commands with an L16 data format. See Data Formats table.

#### **VOUT\_MODE Data Contents**

BIT(S)	SYMBOL	OPERATION
b[7:5]	Vout_mode_type	Reports linear mode. Hard wired to 000b.
b[4:0]	Vout_mode_parameter	Linear mode exponent. 5-bit two's complement integer. Hardwired to 0x13 (-13 decimal).

## PMBus COMMAND DESCRIPTION

### OUTPUT VOLTAGE RELATED COMMANDS

***VOUT\_COMMAND, VOUT\_MAX, VOUT\_MARGIN\_HIGH, VOUT\_MARGIN\_LOW, VOUT\_OV\_FAULT\_LIMIT, VOUT\_OV\_WARN\_LIMIT, VOUT\_UV\_WARN\_LIMIT, VOUT\_UV\_FAULT\_LIMIT, POWER\_GOOD\_ON and POWER\_GOOD\_OFF***

These commands use the same format and provide various servo, margining, and supervising limits for a channel's output voltage. When odd channels are configured to measure current, the OV\_WARN\_LIMIT, UV\_WARN\_LIMIT, OV\_FAULT\_LIMIT and UV\_FAULT\_LIMIT commands are not supported.

#### Data Contents

BIT(S)	SYMBOL	OPERATION
b[15:0]	Vout_command[15:0], Vout_max[15:0], Vout_margin_high[15:0], Vout_margin_low[15:0], Vout_ov_fault_limit[15:0], Vout_ov_warn_limit[15:0], Vout_uv_warn_limit[15:0], Vout_uv_fault_limit[15:0], Power_good_on[15:0], Power_good_off[15:0]	These commands relate to output voltage. The data uses the L16 format. Units: V

### INPUT VOLTAGE RELATED COMMANDS

***VIN\_ON, VIN\_OFF, VIN\_OV\_FAULT\_LIMIT, VIN\_OV\_WARN\_LIMIT, VIN\_UV\_WARN\_LIMIT and VIN\_UV\_FAULT\_LIMIT***

These commands use the same format and provide voltage supervising limits for the input voltage  $V_{IN\_SNS}$ .

#### Data Contents

BIT(S)	SYMBOL	OPERATION
b[15:0]	Vin_on[15:0], Vin_off[15:0], Vin_ov_fault_limit[15:0], Vin_ov_warn_limit[15:0], Vin_uv_warn_limit[15:0], Vin_uv_fault_limit[15:0]	These commands relate to input voltage. The data uses the L11 format. Units: V.

## PMBus COMMAND DESCRIPTION

### TEMPERATURE RELATED COMMANDS

#### *OT\_FAULT\_LIMIT, OT\_WARN\_LIMIT, UT\_WARN\_LIMIT and UT\_FAULT\_LIMIT*

These commands provide supervising limits for temperature.

#### Data Contents

BIT(S)	SYMBOL	OPERATION
b[15:0]	Ot_fault_limit[15:0], Ot_warn_limit[15:0], Ut_warn_limit[15:0], Ut_fault_limit[15:0]	The data uses the L11 format. Units: °C.

### TIMER LIMITS

#### *TON\_DELAY, TON\_RISE, TON\_MAX\_FAULT\_LIMIT and TOFF\_DELAY*

These commands share the same format and provide sequencing and timer fault and warning delays in ms.

TON\_DELAY sets the amount of time in milliseconds that a channel waits following the start of an ON sequence before its V<sub>OUT\_EN</sub> pin enables a DC/DC converter. This delay is counted using SHARE\_CLK only.

TON\_RISE sets the amount of time in ms that elapses after the power supply has been enabled until the LTC2977's DAC soft-connects and servos the output voltage to the desired level if Mfr\_config\_dac\_mode = 00b. This delay is counted using SHARE\_CLK if available, otherwise the internal oscillator is used.

TON\_MAX\_FAULT\_LIMIT is the maximum amount of time that the power supply being controlled by the LTC2977 can attempt to power up the output without reaching the VOUT\_UV\_FAULT\_LIMIT. If the output reaches VOUT\_UV\_FAULT\_LIMIT prior to TON\_MAX\_FAULT\_LIMIT, the LTC2977 unmaskes the VOUT\_UV\_FAULT\_LIMIT threshold. If it does not, then a TON\_MAX\_FAULT is declared. (Note that a value of zero means there is no limit to how long the power supply can attempt to bring up its output voltage.) This delay is counted using SHARE\_CLK if available, otherwise the internal oscillator is used.

TOFF\_DELAY is the amount of time that elapses after the CONTROL<sub>n</sub> pin and/or OPERATION command is deasserted until the channel is disabled (soft-off). This delay is counted using SHARE\_CLK if available, otherwise the internal oscillator is used.

TON\_DELAY and TOFF\_DELAY are internally limited to 13.1 seconds, and rounded to the nearest 10µs when smaller than 655ms, or rounded to the nearest 200µs when larger than 655ms. TON\_RISE and TON\_MAX\_FAULT\_LIMIT are internally limited to 655ms, and rounded to the nearest 10µs. The read value of these commands always returns what was last written and does not reflect internal limiting.

#### Data Contents

BIT(S)	SYMBOL	OPERATION
b[15:0]	Ton_delay[15:0], Ton_rise[15:0], Ton_max_fault[15:0], Toff_delay[15:0]	The data uses the L11 format. Units: ms.

## PMBus COMMAND DESCRIPTION

### FAULT RESPONSE FOR VOLTAGES MEASURED BY THE HIGH SPEED SUPERVISOR

#### *VOUT\_OV\_FAULT\_RESPONSE and VOUT\_UV\_FAULT\_RESPONSE*

The fault response documented here is for voltages that are measured by the high speed supervisor. These voltages are measured over a short period of time and may require a deglitch period. Note that in addition to the response described by these commands, the LTC2977 will also:

- Set the appropriate bit(s) in the STATUS\_BYTE
- Set the appropriate bit(s) in the STATUS\_WORD
- Set the appropriate bit in the corresponding STATUS\_VOUT register, and
- Notify the host by pulling the ALERTB pin low.

Note: Odd numbered channels configured for high resolution ADC measurements (current measurements) will not respond to OV/UV faults or warnings.

#### Data Contents

BIT(S)	SYMBOL	OPERATION
b[7:6]	Vout_ov_fault_response_action, Vout_uv_fault_response_action	Response action: 00b: The unit continues operation without interruption. 01b: The unit continues operating for the delay time specified by bits[2:0] in increments of ts_vs. (See Electrical Characteristics Table, Voltage Supervisor Characteristics section). If the fault is still present at the end of the delay time, the unit shuts down immediately or sequences off after TOFF_DELAY (See Mfr_config_chan_mode). After shutting down, the device responds according to the retry setting in bits [5:3]. 1Xb: The unit shuts down immediately or sequences off after TOFF_DELAY (See Mfr_config_chan_mode). After shutting down, the device responds according to the retry setting in bits [5:3].
b[5:3]	Vout_ov_fault_response_retry, Vout_uv_fault_response_retry	Response retry behavior: 000b: A zero value for the retry setting means that the unit does not attempt to restart. The output remains disabled until the fault is cleared. 001b-111b: The PMBus device attempts to restart the number of times specified by the global Mfr_retry_count[2:0], until it is commanded OFF (by the CONTROL pin or OPERATION command or both), bias power is removed, or another fault condition causes the unit to shut down.
b[2:0]	Vout_ov_fault_response_delay, Vout_uv_fault_response_delay	This sample count determines the amount of time a unit is to ignore a fault after it is first detected. Use this delay to deglitch fast faults. 000b: The unit turns off immediately. 001b-111b: The unit turns off after b[2:0] samples at the sampling period of ts_vs (12.2µs typical).

## PMBus COMMAND DESCRIPTION

### FAULT RESPONSE FOR VALUES MEASURED BY THE ADC

#### *OT\_FAULT\_RESPONSE, UT\_FAULT\_RESPONSE, VIN\_OV\_FAULT\_RESPONSE and VIN\_UV\_FAULT\_RESPONSE*

The fault response documented here is for values that are measured by the ADC. These values are measured over a longer period of time and are not deglitched. Note that in addition to the response described by these commands, the LTC2977 will also:

- Set the appropriate bit(s) in the STATUS\_BYTE
- Set the appropriate bit(s) in the STATUS\_WORD
- Set the appropriate bit in the corresponding STATUS\_VIN or STATUS\_TEMPERATURE register, and
- Notify the host by pulling the ALERTB pin low.

#### Data Contents

BIT(S)	SYMBOL	OPERATION
b[7:6]	Ot_fault_response_action, Ut_fault_response_action, Vin_ov_fault_response_action, Vin_uv_fault_response_action	Response action: 00b: The unit continues operation without interruption. 01b to 11b: The unit shuts down immediately or sequences off after TOFF_DELAY (See Mfr_config_chan_mode). After shutting down, the unit responds according to the retry setting in bits [5:3].
b[5:3]	Ot_fault_response_retry, Ut_fault_response_retry, Vin_ov_fault_response_retry, Vin_uv_fault_response_retry	Response retry behavior: 000b: A zero value for the retry setting means that the unit does not attempt to restart. The output remains disabled until the fault is cleared. 001b-111b: The PMBus device attempts to restart the number of times specified by the global Mfr_retry_count[2:0] until it is commanded OFF (by the CONTROL <sub>n</sub> pin or OPERATION command or both), bias power is removed, or another fault condition causes the unit to shut down.
b[2:0]	Ot_fault_response_delay, Ut_fault_response_delay, Vin_ov_fault_response_delay, Vin_uv_fault_response_delay	Hard coded to 000b. There is no additional deglitch delay applied to fault detection.

## PMBus COMMAND DESCRIPTION

### TIMED FAULT RESPONSE

#### *TON\_MAX\_FAULT\_RESPONSE*

This command defines the LTC2977 response to a TON\_MAX\_FAULT. It may be used to protect against a short-circuited output at start-up. After start-up use VOUT\_UV\_FAULT\_RESPONSE to protect against a short-circuited output.

The device also:

- Sets the HIGH\_BYTE bit in the STATUS\_BYTE,
- Sets the VOUT bit in the STATUS\_WORD,
- Sets the TON\_MAX\_FAULT bit in the STATUS\_VOUT register, and
- Notifies the host by asserting ALERTB.

#### TON\_MAX\_FAULT\_RESPONSE Data Contents

BIT(S)	SYMBOL	OPERATION
b[7:6]	Ton_max_fault_response_action	Response action: 00b: The unit continues operation without interruption. 01b-11b: The unit shuts down immediately or sequences off after TOFF_DELAY (See Mfr_config_chan_mode). After shutting down, the unit responds according to the retry settings in bits [5:3].
b[5:3]	Ton_max_fault_response_retry	Response retry behavior: 000b: A zero value for the Retry Setting means that the unit does not attempt to restart. The output remains disabled until the fault is cleared. 001b-111b: The PMBus device attempts to restart the number of times specified by the global Mfr_retry_count[2:0] until it is commanded OFF (by the CONTROL <sub>n</sub> pin or OPERATION command or both), bias power is removed, or another fault condition causes the unit to shut down.
b[2:0]	Ton_max_fault_response_delay	Hard coded to 000b. There is no additional deglitch delay applied to fault detection.

#### *Clearing Latched Faults*

When a channel shuts down due to a fault, the off state is latched. This is referred to as a latched fault condition. Latched faults are reset by toggling the CONTROL pin, using the OPERATION or ON\_OFF\_CONFIG command, or removing and reapplying the bias voltage to the V<sub>IN\_SNS</sub> pin. All fault and warning conditions result in the ALERTB pin being asserted low and the corresponding bits being set in the status registers. The CLEAR\_FAULTS command resets the contents of the status registers and de-asserts the ALERTB output, but it does not clear a faulted off state nor allow a channel to turn back on.

## PMBus COMMAND DESCRIPTION

### STATUS COMMANDS

#### STATUS\_BYTE

The STATUS\_BYTE command returns the summary of the most critical faults or warnings which have occurred, as shown in the following table. STATUS\_BYTE is a subset of STATUS\_WORD and duplicates the same information.

#### STATUS\_BYTE Data Contents

BIT(S)	SYMBOL	OPERATION
b[7]	Status_byte_busy	Same as Status_word_busy
b[6]	Status_byte_off	Same as Status_word_off
b[5]	Status_byte_vout_ov	Same as Status_word_vout_ov
b[4]	Status_byte_iout_oc	Same as Status_word_iout_oc
b[3]	Status_byte_vin_uv	Same as Status_word_vin_uv
b[2]	Status_byte_temp	Same as Status_word_temp
b[1]	Status_byte_cml	Same as Status_word_cml
b[0]	Status_byte_high_byte	Same as Status_word_high_byte

#### STATUS\_WORD

The STATUS\_WORD command returns two bytes of information with a summary of the unit's fault condition. Based on the information in these bytes, the host can get more information by reading the appropriate detailed status register.

The low byte of the STATUS\_WORD is the same register as the STATUS\_BYTE command.

#### STATUS\_WORD Data Contents

BIT(S)	SYMBOL	OPERATION
b[15]	Status_word_vout	An output voltage fault or warning has occurred. See STATUS_VOUT.
b[14]	Status_word_iout	Not supported. Always returns 0.
b[13]	Status_word_input	An input voltage fault or warning has occurred. See STATUS_INPUT.
b[12]	Status_word_mfr	A manufacturer specific fault has occurred. See STATUS_MFR_SPECIFIC and MFR_STATUS_2.
b[11]	Status_word_power_not_good	The PWRGD pin, if enabled, is negated. Power is not good.
b[10]	Status_word_fans	Not supported. Always returns 0.
b[9]	Status_word_other	Not supported. Always returns 0.
b[8]	Status_word_unknown	Not supported. Always returns 0.
b[7]	Status_word_busy	Device busy when PMBus command received. See OPERATION: Processing Commands.
b[6]	Status_word_off	This bit is asserted if the unit is not providing power to the output, regardless of the reason, including simply not being enabled. The off bit is clear if unit is allowed to provide power to the output.
b[5]	Status_word_vout_ov	An output overvoltage fault has occurred.
b[4]	Status_word_iout_oc	Not supported. Always returns 0.
b[3]	Status_word_vin_uv	A $V_{IN}$ undervoltage fault has occurred.
b[2]	Status_word_temp	A temperature fault or warning has occurred. See STATUS_TEMPERATURE.
b[1]	Status_word_cml	A communication, memory or logic fault has occurred. See STATUS_CML.
b[0]	Status_word_high_byte	A fault/warning not listed in b[7:1] has occurred or Status_word_power_not_good = 1.

## PMBus COMMAND DESCRIPTION

### STATUS\_VOUT

The STATUS\_VOUT command returns the summary of the output voltage faults or warnings which have occurred, as shown in the following table:

#### STATUS\_VOUT Data Contents

BIT(S)	SYMBOL	OPERATION
b[7]	Status_vout_ov_fault	Overvoltage fault.
b[6]	Status_vout_ov_warn	Overvoltage warning.
b[5]	Status_vout_uv_warn	Undervoltage warning
b[4]	Status_vout_uv_fault	Undervoltage fault.
b[3]	Status_vout_max_warn	VOUT_MAX warning. An attempt has been made to set the output voltage to a value higher than allowed by the VOUT_MAX command.
b[2]	Status_vout_ton_max_fault	TON_MAX_FAULT sequencing fault.
b[1]	Status_vout_toff_max_warn	Not supported. Always returns 0.
b[0]	Status_vout_tracking_error	Not supported. Always returns 0.

### STATUS\_INPUT

The STATUS\_INPUT command returns the summary of the  $V_{IN}$  faults or warnings which have occurred, as shown in the following table:

#### STATUS\_INPUT Data Contents

BIT(S)	SYMBOL	OPERATION
b[7]	Status_input_ov_fault	$V_{IN}$ Overvoltage fault
b[6]	Status_input_ov_warn	$V_{IN}$ Overvoltage warning
b[5]	Status_input_uv_warn	$V_{IN}$ Undervoltage warning
b[4]	Status_input_uv_fault	$V_{IN}$ Undervoltage fault
b[3]	Status_input_off	Unit is off for insufficient input voltage.
b[2]	$I_{IN}$ overcurrent fault	Not supported. Always returns 0.
b[1]	$I_{IN}$ overcurrent warn	Not supported. Always returns 0.
b[0]	PIN overpower warn	Not supported. Always returns 0.

### STATUS\_TEMPERATURE

The STATUS\_TEMPERATURE command returns the summary of the temperature faults or warnings which have occurred, as shown in the following table:

#### STATUS\_TEMPERATURE Data Contents

Bit(s)	Symbol	Operation
b[7]	Status_temperature_ot_fault	Overtemperature fault.
b[6]	Status_temperature_ot_warn	Overtemperature warning.
b[5]	Status_temperature_ut_warn	Undertemperature warning.
b[4]	Status_temperature_ut_fault	Undertemperature fault.
b[3:0]	Reserved	Reserved. Always returns 0s.

## PMBus COMMAND DESCRIPTION

### STATUS\_CML

The STATUS\_CML command returns the summary of the communication, memory and logic faults or warnings which have occurred, as shown in the following table:

#### STATUS\_CML Data Contents

BIT(S)	SYMBOL	OPERATION
b[7]	Status_cml_cmd_fault	Illegal or unsupported command fault has occurred.
b[6]	Status_cml_data_fault	Illegal or unsupported data received.
b[5]	Status_cml_pec_fault	A PEC fault has occurred. Note: PEC checking is always active in the LTC2977. Any extra byte received before a STOP will set Status_cml_pec_fault unless the extra byte is a matching PEC byte.
b[4]	Status_cml_memory_fault	A fault has occurred in the EEPROM.
b[3]	Status_cml_processor_fault	Not supported, always returns 0.
b[2]	Reserved	Reserved, always returns 0.
b[1]	Status_cml_pmbus_fault	A communication fault other than ones listed in this table has occurred. This is a catch all category for illegally formed I <sup>2</sup> C/SMBus commands (Example: An address byte with read =1 received immediately after a START).
b[0]	Status_cml_unknown_fault	Not supported, always returns 0.

### STATUS\_MFR\_SPECIFIC

The STATUS\_MFR\_SPECIFIC command returns manufacturer specific status flags. Bits marked CHANNEL=All are not paged. Bits marked STICKY=Yes stay set until a CLEAR\_FAULTS is issued or the channel is commanded on by the user. Bits marked ALERT=Yes pull ALERTB low when the bit is set. Bits marked OFF=Yes indicate that the event can be configured elsewhere to turn the channel off. See MFR\_STATUS\_2 on page 62 for additional bits related to manufacturer specific status.

#### STATUS\_MFR\_SPECIFIC Data Contents

BIT(S)	SYMBOL	OPERATION	CHANNEL	STICKY	ALERT	OFF
b[7]	Status_mfr_discharge	A V <sub>OUT</sub> discharge fault occurred while attempting to enter the ON state	Current Page	Yes	Yes	Yes
b[6]	Status_mfr_fault1_in	This channel attempted to turn on while the FAULTBz1 pin was asserted low, or this channel has shut down at least once in response to a FAULTBz1 pin asserting low since the last CONTROL <sub>n</sub> pin toggle, OPERATION command ON/OFF cycle or CLEAR_FAULTS command.	Current Page	Yes	Yes	Yes
b[5]	Status_mfr_fault0_in	This channel attempted to turn on while the FAULTBz0 pin was asserted low, or this channel has shut down at least once in response to a FAULTBz0 pin asserting low since the last CONTROL <sub>n</sub> pin toggle, OPERATION command ON/OFF cycle or CLEAR_FAULTS command.	Current Page	Yes	Yes	Yes
b[4]	Status_mfr_servo_target_reached	Servo target has been reached.	Current Page	No	No	No
b[3]	Status_mfr_dac_connected	DAC is connected and driving V <sub>DACP</sub> pin.	Current Page	No	No	No
b[2]	Status_mfr_dac_saturated	A previous servo operation terminated with maximum or minimum DAC value.	Current Page	Yes	No	No
b[1]	Status_mfr_vinen_faulted_off	V <sub>IN_EN</sub> has been deasserted due to a V <sub>OUT</sub> fault.	All	No	No	No
b[0]	Status_mfr_watchdog_fault	A watchdog fault has occurred.	All	Yes	Yes	No

## PMBus COMMAND DESCRIPTION

### ADC MONITORING COMMANDS

#### **READ\_VIN**

This command returns the most recent ADC measured value of the voltage measured at the  $V_{IN\_SNS}$  pin.

##### READ\_VIN Data Contents

BIT(S)	SYMBOL	OPERATION
b[15:0]	Read_vin[15:0]	The data uses the L11 format. Units: V

#### **READ\_VOUT**

This command returns the most recent ADC measured value of the channel's output voltage. When odd channels are configured to measure current, the data contents use the L11 format with units in mV.

##### READ\_VOUT Data Contents

BIT(S)	SYMBOL	OPERATION
b[15:0]	Read_vout[15:0]	The data uses the L16 format. Units: V

##### READ\_VOUT Data Contents—for Odd Channels Configured to Measure Current (Mfr\_config\_adc\_hires = 1)

Bit(s)	Symbol	Operation
b[15:0]	Read_vout[15:0]	The data uses the L11 format. Units: mV

#### **READ\_TEMPERATURE\_1**

This command returns the most recent ADC measured value of junction temperature in °C as determined by the LTC2977's internal temperature sensor.

##### READ\_TEMPERATURE\_1 Data Contents

BIT(S)	SYMBOL	OPERATION
b[15:0]	Read_temperature_1 [15:0]	The data uses the L11 format. Units: °C.

#### **PMBUS\_REVISION**

The PMBUS\_REVISION command register is read only and reports the LTC2977 compliance to the PMBus standard revision 1.1.

##### PMBUS\_REVISION Data Contents

BIT(S)	SYMBOL	OPERATION
b[7:0]	PMBus_rev	Reports the PMBus standard revision compliance. This is hard-coded to 0x11 for revision 1.1.

## PMBus COMMAND DESCRIPTION

### MANUFACTURER SPECIFIC COMMANDS

#### MFR\_CONFIG\_LTC2977

This command is used to configure various manufacturer specific operating parameters for each channel.

#### MFR\_CONFIG\_LTC2977 Data Contents

BIT(S)	SYMBOL	OPERATION
b[15:14]	Mfr_config_chan_mode	Select channel specific sequencing mode. 00 = Channel uses PMBus delay sequencing with immediate off upon fault. 01 = Channel uses PMBus delay sequencing with sequence off upon fault. 1x = Channel is a slave in a tracked power supply system.
b[13:12]	Reserved	Don't care. Always returns 0.
b[11]	Mfr_config_fast_servo_off	Disables fast servo when margining or trimming output voltages: 0: fast-servo enabled. 1: fast-servo disabled.
b[10]	Mfr_config_supervisor_resolution	Selects supervisor resolution: 0: high resolution = 4mV/LSB, range for $V_{VSENSEp_n} - V_{VSENSEM_n}$ is 0V to 3.8V. 1: low resolution = 8mV/LSB, range for $V_{VSENSEp_n} - V_{VSENSEM_n}$ is 0V to 6.0V.
b[9]	Mfr_config_adc_hires	Selects ADC resolution for odd channels. This is typically used to measure current. Ignored for even channels (they always use low resolution). 0: low resolution = 122 $\mu$ V/LSB. 1: high resolution = 15.6 $\mu$ V/LSB.
b[8]	Mfr_config_controln_sel	Selects the active control pin input (CONTROL0 or CONTROL1) for this channel. 0: Select CONTROL0 pin. 1: Select CONTROL1 pin.
b[7]	Mfr_config_servo_continuous	Select whether the UNIT should continuously servo $V_{OUT}$ after it has reached a new margin or nominal target. Only applies when Mfr_config_dac_mode = 00b. 0: Do not continuously servo $V_{OUT}$ after reaching initial target. 1: Continuously servo $V_{OUT}$ to target.
b[6]	Mfr_config_servo_on_warn	Control re-servo on warning feature. Only applies when Mfr_config_dac_mode = 00b and Mfr_config_servo_continuous = 0. 0: Do not allow the unit to re-servo when a $V_{OUT}$ warning threshold is met or exceeded. 1: Allow the unit to re-servo $V_{OUT}$ to nominal target if $V_{OUT} \geq V(V_{out\_ov\_warn\_limit})$ or $V_{OUT} \leq V(V_{out\_uv\_warn\_limit})$ .
b[5:4]	Mfr_config_dac_mode	Determines how DAC is used when channel is in the ON state and TON_RISE has elapsed. 00: Soft-connect (if needed) and servo to target. 01: DAC not connected. 10: DAC connected immediately using value from MFR_DAC command. If this is the configuration after a reset or RESTORE_USER_ALL, MFR_DAC will be undefined and must be written to desired value. 11: DAC is soft-connected. After soft-connect is complete MFR_DAC may be written.
b[3]	Mfr_config_vo_en_wpu_en	$V_{OUT\_EN}$ pin charge-pumped, current-limited pull-up enable. 0: Disable weak pull-up. $V_{OUT\_EN}$ pin driver is three-stated when channel is on. 1: Use weak current-limited pull-up on $V_{OUT\_EN}$ pin when the channel is on. For channels 4-7 this bit is treated as a 0 regardless of its value.
b[2]	Mfr_config_vo_en_wpd_en	$V_{OUT\_EN}$ pin current-limited pull-down enable. 0: Use a fast N-channel device to pull down $V_{OUT\_EN}$ pin when the channel is off for any reason. 1: Use weak current-limited pull-down to discharge $V_{OUT\_EN}$ pin when channel is off due to soft stop by the CONTROL $n$ pin and/or OPERATION command. If the channel is off due to a fault, use the fast pull-down on $V_{OUT\_EN}$ pin. For channels 4-7 this bit is treated as a 0 regardless of its value.

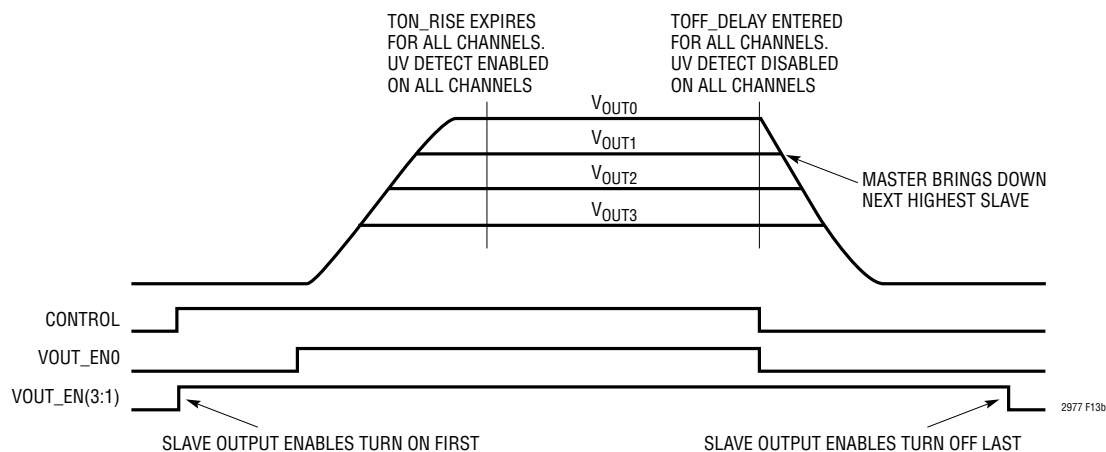


## PMBus COMMAND DESCRIPTION

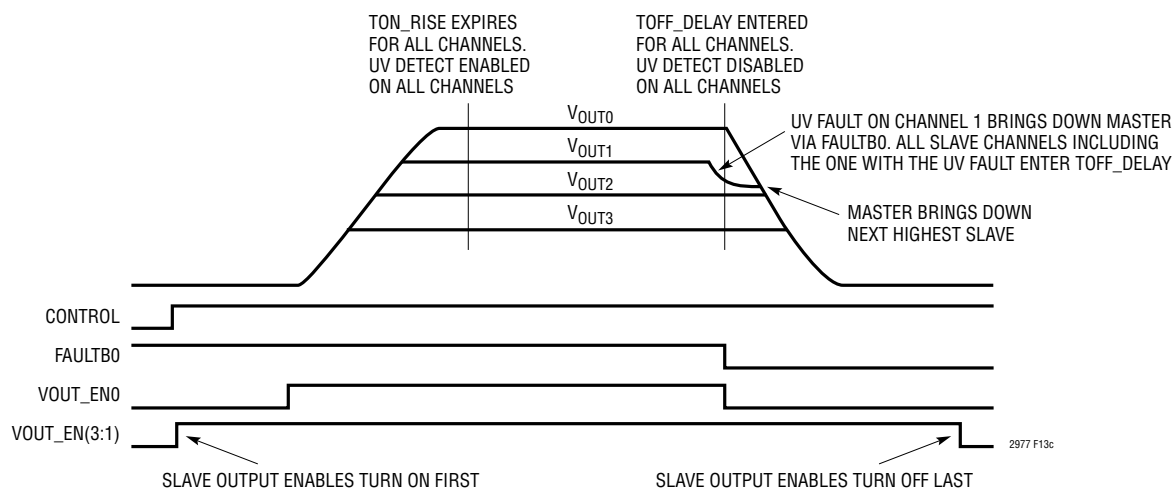
An important feature of the LTC2977 is the ability to control, monitor, and supervise DC/DC converters that are configured to track a master supply on and off.

The LTC2977 supports the following tracking features:

- Track channels on and off without issuing false UV events when the slave channels are tracking up or down.
- Track all channels down in response to a fault from a slave or master.
- Track all channels down when VIN\_SNS drops below VIN\_OFF, share clock is held low or RESTORE\_USER\_ALL is issued.
- Ability to reconfigure selected channels that are part of a tracking group to sequence up after the group has tracked up or sequence down before the group has tracked down.

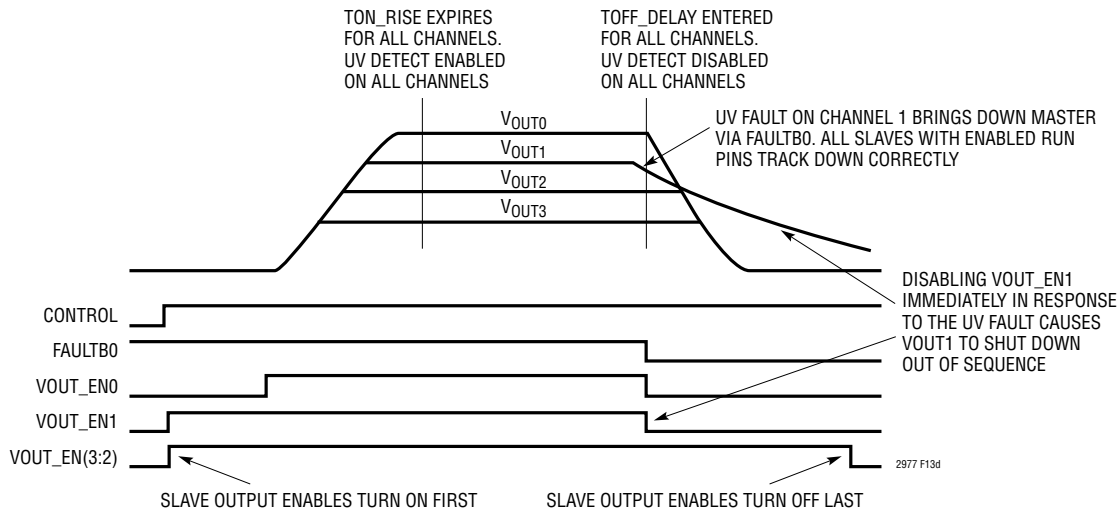


**Figure 13b. Control Pin Tracking All Supplies Up And Down**



**Figure 13c. Fault on Channel 1 Tracking All Supplies Down**

## PMBus COMMAND DESCRIPTION



**Figure 13d. Improperly Configured Fault Response on Faulting Channel Disrupts Tracking**

### Tracking Implementation

The LTC2977 supports tracking through the coordinated programming of `Ton_delay`, `Ton_rise`, `Toff_delay` and `Mfr_config_chan_mode`. The master channel must be configured to turn on after all the slave channels have turned on and to turn off before all the slave channels turn off. Slaves that are enabled before the master will remain off until the tracking pin allows them to turn on. Slaves will be turned off via the tracking pin even though their run pin is still asserted. `Ton_rise` must be extended on the slaves so that it ends relative to the rise of the TRACK pin and not the rise of the `VOUT_EN` pin.

When `Mfr_config_chan_mode = 1Xb` the channel is reconfigured to:

- Sequence down on fault, `VIN_OFF`, `SHARE_CLK` low or `RESTORE_USER_ALL`.
- Ignore UV during `TOFF_DELAY`. Note that ignoring UV during `TON_RISE` and `TON_MAX_FAULT` always happens regardless of how these configuration bits are set.

The following example illustrates configuring an LTC2977 with one master channel and three slaves.

Master channel 0

`TON_DELAY = Ton_delay_master`

`TON_RISE = Ton_rise_master`

`TOFF_DELAY = Toff_delay_master`

`Mfr_config_chan_mode = 00`

Slave channel *n*

`TON_DELAY = Ton_delay_slave`

`TON_RISE = Ton_delay_master + Ton_rise_slave`

## PMBus COMMAND DESCRIPTION

$TOFF\_DELAY = Toff\_delay\_master + Toff\_delay\_slave$

$Mfr\_config\_chan\_mode = 10b$

Where:

$Ton\_delay\_master - Ton\_delay\_slave > RUN$  to TRACK setup time

$Toff\_delay\_slave >$  time for master supply to fall.

The system response to a control pin toggle is illustrated in Figure 13b.

The system response to a UV fault on a slave channel is illustrated in Figure 13c.

### MFR\_CONFIG\_ALL\_LTC2977

This command is used to configure parameters that are common to all channels on the IC. They may be set or reviewed from any PAGE setting.

#### MFR\_CONFIG\_ALL\_LTC2977 Data Contents

BIT(S)	SYMBOL	OPERATION
b[15-13]	Reserved	Don't care. Always returns 0
b[12]	Mfr_config_all_en_short_cycle_fault	Enable short cycle fault detection. See Mfr_status_2_short_cycle_fault on page 62 for more information. 0: Issuing an ON before prior OFF is complete will not cause a fault. 1: Issuing an ON before prior OFF is complete will cause a fault.
b[11]	Mfr_config_all_pwrzd_off_uses_uv	Selects PWRGD de-assertion source for all channels. 0: PWRGD is de-asserted based on $V_{OUT}$ being below or equal to POWER_GOOD_OFF. This option uses the ADC. Response time is approximately 100ms to 200ms. 1: PWRGD is de-asserted based on $V_{OUT}$ being below or equal to VOUT_UV_LIMIT. This option uses the high speed supervisor. Response time is approximately 12 $\mu$ s
b[10]	Mfr_config_all_fast_fault_log	Controls number of ADC readings completed before transferring fault log memory to EEPROM. 0: Slower. All ADC telemetry values will be updated before transferring fault log to EEPROM. 1: Faster. Telemetry values will be transferred from fault log to EEPROM within 24ms after detecting fault.
b[9:8]	Reserved	Don't care. Always returns 0
b[7]	Mfr_config_all_fault_log_enable	Enable fault logging to EEPROM in response to Fault. 0: Fault logging to EEPROM is disabled 1: Fault logging to EEPROM is enabled
b[6]	Mfr_config_all_vin_on_clr_faults_en	Allow $V_{IN}$ rising above VIN_ON to clear all latched faults 0: VIN_ON clear faults feature is disabled 1: VIN_ON clear faults feature is enabled
b[5]	Mfr_config_all_control1_pol	Selects active polarity of CONTROL1 pin. 0: Active low (pull pin low to start unit) 1: Active high (pull pin high to start unit)
b[4]	Mfr_config_all_control0_pol	Selects active polarity of CONTROL0 pin. 0: Active low (pull pin low to start unit) 1: Active high (pull pin high to start unit)
b[3]	Mfr_config_all_vin_share_enable	Allow this unit to hold SHARE_CLK pin low when $V_{IN}$ has not risen above VIN_ON or has fallen below VIN_OFF. When enabled, this unit will also turn all channels off in response to SHARE_CLK being held low. 0: SHARE_CLK inhibit is disabled 1: SHARE_CLK inhibit is enabled

## PMBus COMMAND DESCRIPTION

### MFR\_CONFIG\_ALL\_LTC2977 Data Contents

BIT(S)	SYMBOL	OPERATION
b[2]	Mfr_config_all_pec_en	PMBus packet error checking enable. 0: PEC is accepted but not required 1: PEC is required
b[1]	Mfr_config_all_longer_pmbus_timeout	Increase PMBus timeout internal by a factor of 8. Recommended for fault logging. 0: PMBus timeout is not multiplied by a factor of 8 1: PMBus timeout is multiplied by a factor of 8
b[0]	Mfr_config_all_vinen_wpu_dis	V <sub>IN_EN</sub> charge-pumped, current-limited pull-up disable. 0: Use weak current-limited pull-up on V <sub>IN_EN</sub> after power-up, as long as no faults have forced V <sub>IN_EN</sub> off. 1: Disable weak pull-up. V <sub>IN_EN</sub> driver is three-stated after power-up as long as no faults have forced V <sub>IN_EN</sub> off.

### MFR\_FAULTBz0\_PROPAGATE, MFR\_FAULTBz1\_PROPAGATE

These manufacturer specific commands enable channels that have faulted off to propagate that state to the appropriate fault pin. Faulted off states for pages 0 through 3 can only be propagated to pins FAULTB00 and FAULTB01; this is referred to as zone 0. Faulted off states for pages 4 through 7 can only be propagated to pins FAULTB10 and FAULTB11; this is referred to as zone 1. The z designator in the command name is used to indicate that this command affects different zones depending on the page. See Figure 20.

Note that pulling a fault pin low will have no effect for channels that have MFR\_FAULTBzn\_RESPONSE set to 0. The channel continues operation without interruption. This fault response is called Ignore (0x0) in LTpowerPlay.

### MFR\_FAULTBz0\_PROPAGATE Data Content

BIT(S)	SYMBOL	OPERATION
b[7:1]	Reserved	Don't care. Always returns 0.
b[0]	Mfr_faultbz0_propagate	Enable fault propagation. For pages 0 through 3, zone 0 0: Channel's faulted off state does not assert FAULTB00 low. 1: Channel's faulted off state asserts FAULTB00 low. For pages 4 through 7, zone 1 0: Channel's faulted off state does not assert FAULTB10 low. 1: Channel's faulted off state asserts FAULTB10 low.

### MFR\_FAULTBz1\_PROPAGATE Data Content

BIT(S)	SYMBOL	OPERATION
b[7:1]	Reserved	Don't care. Always returns 0.
b[0]	Mfr_faultbz1_propagate	Enable fault propagation. For pages 0 through 3, zone 0 0: Channel's faulted off state does not assert FAULTB01 low. 1: Channel's faulted off state asserts FAULTB01 low. For pages 4 through 7, zone 1 0: Channel's faulted off state does not assert FAULTB11 low. 1: Channel's faulted off state asserts FAULTB11 low.

## PMBus COMMAND DESCRIPTION

### MFR\_PWRGD\_EN

This command register controls the mapping of the watchdog and channel power good status to the PWRGD pin. Note that odd numbered channels whose ADC is in high res mode do not contribute to power good.

#### MFR\_PWRGD\_EN Data Contents

BIT(S)	SYMBOL	OPERATION
b[15:9]	Reserved	Read only, always returns 0s.
b[8]	Mfr_pwrzd_en_wdog	Watchdog 1 = Watchdog timer not-expired status is ANDed with PWRGD status for any similarly enabled channels to determine when the PWRGD pin gets asserted. 0 = Watchdog timer does not affect the PWRGD pin.
b[7]	Mfr_pwrzd_en_chan7	Channel 7 1 = PWRGD status for this channel is ANDed with PWRGD status for any similarly enabled channels to determine when the PWRGD pin gets asserted. 0 = PWRGD status for this channel does not affect the PWRGD pin.
b[6]	Mfr_pwrzd_en_chan6	Channel 6 1 = PWRGD status for this channel is ANDed with PWRGD status for any similarly enabled channels to determine when the PWRGD pin gets asserted. 0 = PWRGD status for this channel does not affect the PWRGD pin.
b[5]	Mfr_pwrzd_en_chan5	Channel 5 1 = PWRGD status for this channel is ANDed with PWRGD status for any similarly enabled channels to determine when the PWRGD pin gets asserted. 0 = PWRGD status for this channel does not affect the PWRGD pin.
b[4]	Mfr_pwrzd_en_chan4	Channel 4 1 = PWRGD status for this channel is ANDed with PWRGD status for any similarly enabled channels to determine when the PWRGD pin gets asserted. 0 = PWRGD status for this channel does not affect the PWRGD pin.
b[3]	Mfr_pwrzd_en_chan3	Channel 3 1 = PWRGD status for this channel is ANDed with PWRGD status for any similarly enabled channels to determine when the PWRGD pin gets asserted. 0 = PWRGD status for this channel does not affect the PWRGD pin.
b[2]	Mfr_pwrzd_en_chan2	Channel 2 1 = PWRGD status for this channel is ANDed with PWRGD status for any similarly enabled channels to determine when the PWRGD pin gets asserted. 0 = PWRGD status for this channel does not affect the PWRGD pin.
b[1]	Mfr_pwrzd_en_chan1	Channel 1 1 = PWRGD status for this channel is ANDed with PWRGD status for any similarly enabled channels to determine when the PWRGD pin gets asserted. 0 = PWRGD status for this channel does not affect the PWRGD pin.
b[0]	Mfr_pwrzd_en_chan0	Channel 0 1 = PWRGD status for this channel is ANDed with PWRGD status for any similarly enabled channels to determine when the PWRGD pin gets asserted. 0 = PWRGD status for this channel does not affect the PWRGD pin.

## PMBus COMMAND DESCRIPTION

### *MFR\_FAULTB00\_RESPONSE, MFR\_FAULTB01\_RESPONSE, MFR\_FAULTB10\_RESPONSE and MFR\_FAULTB11\_RESPONSE*

These manufacturer specific commands share the same format and specify the response to assertions of the FAULTB pins. For fault zone 0, MFR\_FAULTB00\_RESPONSE determines whether channels 0 to 3 shut off when the FAULTB00 pin is asserted, and MFR\_FAULTB01\_RESPONSE determines whether channels 0 to 3 shut off when the FAULTB01 pin is asserted. For fault zone 1, MFR\_FAULTB10\_RESPONSE determines whether channels 4 to 7 shut off when the FAULTB10 pin is asserted, and MFR\_FAULTB11\_RESPONSE determines whether channels 4 to 7 shut off when the FAULTB11 pin is asserted. When a channel shuts off in response to a FAULTB pin, the ALERTB pin is asserted low and the appropriate bit is set in the STATUS\_MFR\_SPECIFIC register. For a graphical explanation, see the switches on the left hand side of Figure 20, Channel Fault Management Block Diagram.

#### Data Contents—Fault Zone 0 Response Commands

BIT(S)	SYMBOL	OPERATION
b[7:4]	Reserved	Read only, always returns 0s.
b[3]	Mfr_faultb00_response_chan3, Mfr_faultb01_response_chan3	Channel 3 response. 0: The channel continues operation without interruption. 1: The channel shuts down if the corresponding FAULTB <sub>n</sub> pin is still asserted after 10μs. When the FAULTB <sub>n</sub> pin subsequently deasserts, the channel turns back on, honoring TON_DELAY and TON_RISE settings.
b[2]	Mfr_faultb00_response_chan2, Mfr_faultb01_response_chan2	Channel 2 response. 0: The channel continues operation without interruption. 1: The channel shuts down if the corresponding FAULTB <sub>n</sub> pin is still asserted after 10μs. When the FAULTB <sub>n</sub> pin subsequently deasserts, the channel turns back on, honoring TON_DELAY and TON_RISE settings.
b[1]	Mfr_faultb00_response_chan1, Mfr_faultb01_response_chan1	Channel 1 response. 0: The channel continues operation without interruption. 1: The channel shuts down if the corresponding FAULTB <sub>n</sub> pin is still asserted after 10μs. When the FAULTB <sub>n</sub> pin subsequently deasserts, the channel turns back on, honoring TON_DELAY and TON_RISE settings.
b[0]	Mfr_faultb00_response_chan0, Mfr_faultb01_response_chan0	Channel 0 response. 0: The channel continues operation without interruption. 1: The channel shuts down if the corresponding FAULTB <sub>n</sub> pin is still asserted after 10μs. When the FAULTB <sub>n</sub> pin subsequently deasserts, the channel turns back on, honoring TON_DELAY and TON_RISE settings.

#### Data Contents—Fault Zone 1 Response Commands

BIT(S)	SYMBOL	OPERATION
b[7:4]	Reserved	Read only, always returns 0s.
b[3]	Mfr_faultb10_response_chan7, Mfr_faultb11_response_chan7	Channel 7 response. 0: The channel continues operation without interruption. 1: The channel shuts down if the corresponding FAULTB <sub>n</sub> pin is still asserted after 10μs. When the FAULTB <sub>n</sub> pin subsequently deasserts, the channel turns back on, honoring TON_DELAY and TON_RISE settings.
b[2]	Mfr_faultb10_response_chan6, Mfr_faultb11_response_chan6	Channel 6 response. 0: The channel continues operation without interruption. 1: The channel shuts down if the corresponding FAULTB <sub>n</sub> pin is still asserted after 10μs. When the FAULTB <sub>n</sub> pin subsequently deasserts, the channel turns back on, honoring TON_DELAY and TON_RISE settings.
b[1]	Mfr_faultb10_response_chan5, Mfr_faultb11_response_chan5	Channel 5 response. 0: The channel continues operation without interruption. 1: The channel shuts down if the corresponding FAULTB <sub>n</sub> pin is still asserted after 10μs. When the FAULTB <sub>n</sub> pin subsequently deasserts, the channel turns back on, honoring TON_DELAY and TON_RISE settings.
b[0]	Mfr_faultb10_response_chan4, Mfr_faultb11_response_chan4	Channel 4 response. 0: The channel continues operation without interruption. 1: The channel shuts down if the corresponding FAULTB <sub>n</sub> pin is still asserted after 10μs. When the FAULTB <sub>n</sub> pin subsequently deasserts, the channel turns back on, honoring TON_DELAY and TON_RISE settings.

## PMBus COMMAND DESCRIPTION

### *MFR\_VINEN\_OV\_FAULT\_RESPONSE*

This command register determines whether  $V_{OUT}$  overvoltage faults from a given channel cause the  $V_{IN\_EN}$  pin to be pulled low.

#### **MFR\_VINEN\_OV\_FAULT\_RESPONSE Data Contents**

BIT(S)	SYMBOL	OPERATION
b[7]	Mfr_vinen_ov_fault_response_chan7	Response to channel 7 VOUT_OV_FAULT. 1 = Disable (pull low) $V_{IN\_EN}$ via fast pull-down. 0 = Do not disable $V_{IN\_EN}$ .
b[6]	Mfr_vinen_ov_fault_response_chan6	Response to channel 6 VOUT_OV_FAULT. 1 = Disable (pull low) $V_{IN\_EN}$ via fast pull-down. 0 = Do not disable $V_{IN\_EN}$ .
b[5]	Mfr_vinen_ov_fault_response_chan5	Response to channel 5 VOUT_OV_FAULT. 1 = Disable (pull low) $V_{IN\_EN}$ via fast pull-down. 0 = Do not disable $V_{IN\_EN}$ .
b[4]	Mfr_vinen_ov_fault_response_chan4	Response to channel 4 VOUT_OV_FAULT. 1 = Disable (pull low) $V_{IN\_EN}$ via fast pull-down. 0 = Do not disable $V_{IN\_EN}$ .
b[3]	Mfr_vinen_ov_fault_response_chan3	Response to channel 3 VOUT_OV_FAULT. 1 = Disable (pull low) $V_{IN\_EN}$ via fast pull-down. 0 = Do not disable $V_{IN\_EN}$ .
b[2]	Mfr_vinen_ov_fault_response_chan2	Response to channel 2 VOUT_OV_FAULT. 1 = Disable (pull low) $V_{IN\_EN}$ via fast pull-down. 0 = Do not disable $V_{IN\_EN}$ .
b[1]	Mfr_vinen_ov_fault_response_chan1	Response to channel 1 VOUT_OV_FAULT. 1 = Disable (pull low) $V_{IN\_EN}$ via fast pull-down. 0 = Do not disable $V_{IN\_EN}$ .
b[0]	Mfr_vinen_ov_fault_response_chan0	Response to channel 0 VOUT_OV_FAULT. 1 = Disable (pull low) $V_{IN\_EN}$ via fast pull-down. 0 = Do not disable $V_{IN\_EN}$ .

## PMBus COMMAND DESCRIPTION

### MFR\_VINEN\_UV\_FAULT\_RESPONSE

This command register determines whether  $V_{OUT}$  undervoltage faults from a given channel cause the  $V_{IN\_EN}$  pin to be pulled low.

#### MFR\_VINEN\_UV\_FAULT\_RESPONSE Data Contents

BIT(S)	SYMBOL	OPERATION
b[7]	Mfr_vinen_uv_fault_response_chan7	Response to channel 7 $V_{OUT\_UV\_FAULT}$ . 1 = Disable (pull low) $V_{IN\_EN}$ via fast pull-down. 0 = Do not disable $V_{IN\_EN}$ .
b[6]	Mfr_vinen_uv_fault_response_chan6	Response to channel 6 $V_{OUT\_UV\_FAULT}$ . 1 = Disable (pull low) $V_{IN\_EN}$ via fast pull-down. 0 = Do not disable $V_{IN\_EN}$ .
b[5]	Mfr_vinen_uv_fault_response_chan5	Response to channel 5 $V_{OUT\_UV\_FAULT}$ . 1 = Disable (pull low) $V_{IN\_EN}$ via fast pull-down. 0 = Do not disable $V_{IN\_EN}$ .
b[4]	Mfr_vinen_uv_fault_response_chan4	Response to channel 4 $V_{OUT\_UV\_FAULT}$ . 1 = Disable (pull low) $V_{IN\_EN}$ via fast pull-down. 0 = Do not disable $V_{IN\_EN}$ .
b[3]	Mfr_vinen_uv_fault_response_chan3	Response to channel 3 $V_{OUT\_UV\_FAULT}$ . 1 = Disable (pull low) $V_{IN\_EN}$ via fast pull-down. 0 = Do not disable $V_{IN\_EN}$ .
b[2]	Mfr_vinen_uv_fault_response_chan2	Response to channel 2 $V_{OUT\_UV\_FAULT}$ . 1 = Disable (pull low) $V_{IN\_EN}$ via fast pull-down. 0 = Do not disable $V_{IN\_EN}$ .
b[1]	Mfr_vinen_uv_fault_response_chan1	Response to channel 1 $V_{OUT\_UV\_FAULT}$ . 1 = Disable (pull low) $V_{IN\_EN}$ via fast pull-down. 0 = Do not disable $V_{IN\_EN}$ .
b[0]	Mfr_vinen_uv_fault_response_chan0	Response to channel 0 $V_{OUT\_UV\_FAULT}$ . 1 = Disable (pull low) $V_{IN\_EN}$ via fast pull-down. 0 = Do not disable $V_{IN\_EN}$ .

## PMBus COMMAND DESCRIPTION

### ***MFR\_RETRY\_COUNT***

The MFR\_RETRY\_COUNT is a global command that sets the number of retries attempted when any channel faults off with its fault response retry field set to a non zero value.

In the event of multiple or recurring retry faults on the same channel the total number of retries equals MFR\_RETRY\_COUNT. If a channel has not been faulted off for 6 seconds, its retry counter is cleared. Toggling a channel's CONTROL pin off then on or issuing OPERATION off then on commands will synchronously clear the retry count. Writing to MFR\_RETRY\_COUNT clears the retry count for all channels

#### **MFR\_RETRY\_COUNT Data Contents**

BIT(S)	SYMBOL	OPERATION
b[7:3]	Reserved	Always returns zero.
b[2:0]	Mfr_retry_count [2:0]	0: No retries: 1-6: Number of retries. 7: Infinite retries.

### ***MFR\_RETRY\_DELAY***

This command determines the retry interval when the LTC2977 is in retry mode in response to a fault condition. The read value of this command always returns what was last written and does not reflect internal limiting.

#### **MFR\_RETRY\_DELAY Data Contents**

BIT(S)	SYMBOL	OPERATION
b[15:0]	Mfr_retry_delay	The data uses the L11 format. This delay is counted using SHARE_CLK only. Delays are rounded to the nearest 200µs. Units: ms. Max delay is 13.1 sec.

### ***MFR\_RESTART\_DELAY***

This command sets the minimum off time of a CONTROL initiated restart. If the CONTROL pin is toggled off for at least 10µs then on, all dependent channels are disabled, held off for a time = Mfr\_restart\_delay, then sequenced back on. CONTROL<sub>n</sub> pin transitions whose OFF time exceeds Mfr\_restart\_delay are not affected by this command. A value of all zeros disables this feature. The read value of this command always returns what was last written and does not reflect internal limiting.

#### **MFR\_RESTART\_DELAY Data Contents**

BIT(S)	SYMBOL	OPERATION
b[15:0]	Mfr_restart_delay	The data uses the L11 format. This delay is counted using SHARE_CLK only. Delays are rounded to the nearest 200µs. Units: ms. Max delay is 13.1 sec.

## PMBus COMMAND DESCRIPTION

### ***MFR\_VOUT\_PEAK***

This command returns the maximum ADC measured value of the channel's output voltage. This command is not supported for odd channels that are configured to measure current. This register is reset to 0xF800 (0.0) when the LTC2977 emerges from power-on reset, or when a CLEAR\_FAULTS command to the page is executed, or the channel goes through an off-to-on transition.

#### **MFR\_VOUT\_PEAK Data Contents**

BIT(S)	SYMBOL	OPERATION
b[15:0]	Mfr_vout_peak[15:0]	The data uses the L16 format. Units: V.

### ***MFR\_VIN\_PEAK***

This command returns the maximum ADC measured value of the input voltage. This register is reset to 0x7C00 ( $-2^{25}$ ) when the LTC2977 emerges from power-on reset, or when a CLEAR\_FAULTS command to any page is executed, or a channel goes through an off-to-on transition.

#### **MFR\_VIN\_PEAK Data Contents**

BIT(S)	SYMBOL	OPERATION
b[15:0]	Mfr_vin_peak[15:0]	The data uses the L11 format. Units: V

### ***MFR\_TEMPERATURE\_PEAK***

This command returns the maximum ADC measured value of junction temperature in °C as determined by the LTC2977's internal temperature sensor. This register is reset to 0x7C00 ( $-2^{25}$ ) when the LTC2977 emerges from power-on reset, when a CLEAR\_FAULTS command to any page is executed, or a channel goes through an off-to-on transition.

#### **MFR\_TEMPERATURE\_PEAK Data Contents**

BIT(S)	SYMBOL	OPERATION
b[15:0]	Mfr_temperature_peak[15:0]	The data uses the L11 format. Units: °C.

### ***MFR\_DAC***

This command register allows the user to directly program the 10-bit DAC. Manual DAC writes require the channel to be in the ON state, TON\_RISE to have expired and MFR\_CONFIG\_LTC2977 b[5:4] = 10b or 11b. Writing MFR\_CONFIG\_LTC2977 b[5:4] = 10b commands the DAC to hard-connect with the value in Mfr\_dac\_direct\_val. Writing b[5:4] = 11b commands the DAC to soft-connect. Once the DAC has soft-connected, Mfr\_dac\_direct\_val returns the value that allowed the DAC to be connected without perturbing the power supply. MFR\_DAC writes are ignored when MFR\_CONFIG\_LTC2977 b[5:4] = 00b or 01b.

#### **MFR\_DAC Data Contents**

BIT(S)	SYMBOL	OPERATION
b[15:10]	Reserved	Read only, always returns 0.
b[9:0]	Mfr_dac_direct_val	DAC code value.

## PMBus COMMAND DESCRIPTION

### MFR\_POWERGOOD\_ASSERTION\_DELAY

This command register allows the user to program the delay from when the internal power good signal becomes valid until the power good output is asserted. This delay is counted using SHARE\_CLK if available, otherwise the internal oscillator is used. This delay is internally limited to 13.1 seconds, and rounded to the nearest 200µs. The read value of this command always returns what was last written and does not reflect internal limiting.

The power good de-assertion delay and threshold source is controlled by Mfr\_config\_all\_pwrzd\_off\_uses\_uv. Systems that require a fast power good de-assertion should set Mfr\_config\_all\_pwrzd\_off\_uses\_uv=1. This uses the VOUT\_UV\_FAULT\_LIMIT and the high speed comparator to de-assert the PWRGD pin. Systems that require a separate power good off threshold should set Mfr\_config\_all\_pwrzd\_off\_uses\_uv=0. This uses the slower ADC polling loop and POWER\_GOOD\_OFF to de-assert the PWRGD pin.

#### MFR\_POWERGOOD\_ASSERTION\_DELAY Data Contents

BIT(S)	SYMBOL	OPERATION
b[15:0]	Mfr_powergood_assertion_delay	The data uses the L11 format. This delay is counted using SHARE_CLK if available, otherwise the internal oscillator is used. Delays are rounded to the nearest 200µs. Units: ms. Max delay is 13.1 sec.

### MFR\_PADS

The MFR\_PADS command provides read only access to slow frequency digital pads (pins). The input values presented in bits[9:0] are before any deglitching logic.

#### MFR\_PADS Data Contents

BIT(S)	SYMBOL	OPERATION
b[15]	Mfr_pads_pwrzd_drive	0 = PWRGD pad is being driven low by this chip 1 = PWRGD pad is not being driven low by this chip
b[14]	Mfr_pads_alertb_drive	0 = ALERTB pad is being driven low by this chip 1 = ALERTB pad is not being driven low by this chip
b[13:10]	Mfr_pads_faultb_drive[3:0]	Bit[3] used for FAULTB00 pad, bit[2] used for FAULTB01 pad, bit[1] used for FAULTB10 pad, bit[0] used for FAULTB11 pad as follows: 0 = FAULTBzn pad is being driven low by this chip 1 = FAULTBzn pad is not being driven low by this chip
b[9:8]	Mfr_pads_asel1[1:0]	11: Logic high detected on ASEL1 input pad 10: ASEL1 input pad is floating 01: Reserved 00: Logic low detected on ASEL1 input pad
b[7:6]	Mfr_pads_asel0[1:0]	11: Logic high detected on ASELO input pad 10: ASELO input pad is floating 01: Reserved 00: Logic low detected on ASELO input pad
b[5]	Mfr_pads_control1	1: Logic high detected on CONTROL1 pad 0: Logic low detected on CONTROL1 pad
b[4]	Mfr_pads_control0	1: Logic high detected on CONTROL0 pad 0: Logic low detected on CONTROL0 pad

## PMBus COMMAND DESCRIPTION

### MFR\_PADS Data Contents

BIT(S)	SYMBOL	OPERATION
b[3:0]	Mfr_pads_faultb[3:0]	Bit[3] used for FAULTB00 pad, bit[2] used for FAULTB01 pad, bit[1] used for FAULTB10 pad, bit[0] used for FAULTB11 pad as follows: 1: Logic high detected on FAULTBzn pad 0: Logic low detected on FAULTBzn pad

### MFR\_SPECIAL\_ID

This register contains the manufacturer ID for the LTC2977.

### MFR\_SPECIAL\_ID Data Contents

BIT(S)	SYMBOL	OPERATION
b[15:0]	Mfr_special_id	Read only, always returns 0x0131

### MFR\_SPECIAL\_LOT

These paged registers contain information that identifies the user configuration that was programmed at the factory. Contact the factory to request a custom factory programmed user configuration and special lot number.

### MFR\_SPECIAL\_LOT Data Contents

BIT(S)	SYMBOL	OPERATION
b[7:0]	Mfr_special_lot	Contains the LTC default special lot number. Contact the factory to request a custom factory programmed user configuration and special lot number.

### MFR\_INFO

The MFR\_INFO register contains manufacturer specific information and is updated after a power-on reset, a RESTORE\_USER\_ALL command, or an EEPROM bulk read operation.

### MFR\_INFO Data Contents

BIT(S)	SYMBOL	OPERATION
b[15:6]	Reserved	Reserved
b[5]	Mfr_info_ecc_user	EEPROM ECC status. 0: Corrections made in the EEPROM user space 1: No corrections made in the EEPROM user space
b[4:0]	Reserved	Reserved

## PMBus COMMAND DESCRIPTION

### ***MFR\_VOUT\_DISCHARGE\_THRESHOLD***

This register contains the coefficient that multiplies VOUT\_COMMAND in order to determine the OFF threshold voltage for the associated output. If the output voltage has not decayed below MFR\_VOUT\_DISCHARGE\_THRESHOLD • VOUT\_COMMAND prior to the channel being commanded to enter/re-enter the ON state, the Status\_mfr\_discharge bit in the STATUS\_MFR\_SPECIFIC register will be set and the ALERTB pin will be asserted low. In addition, the channel will not enter the ON state until the output has decayed below its OFF threshold voltage. Setting this to a value greater than 1.0 effectively disables DISCHARGE\_THRESHOLD checking, allowing the channel to turn back on even if it has not decayed at all.

Other channels can be held off if a particular output has failed to discharge by using the bidirectional FAULTBzn pins (refer to the MFR\_FAULTBzn\_RESPONSE and MFR\_FAULTBzn\_PROPAGATE registers).

#### **MFR\_VOUT\_DISCHARGE\_THRESHOLD Data Contents**

BIT(S)	SYMBOL	OPERATION
b[15:0]	Mfr_vout_discharge_threshold	The data uses the L11 format. Units: Dimensionless, this register contains a coefficient.

### ***MFR\_COMMON***

This command returns status information for the alert pin (ALERTB), share-clock pin (SHARE\_CLK), write-protect pin (WP), and device busy state.

This is the only command that may still be read when the device is busy processing an EEPROM or other command. It may be polled by the host to determine when the device is available to process a PMBus command. A busy device will always acknowledge its address but will NACK the command byte and set Status\_byte\_busy and Status\_word\_busy when it receives a command that it cannot immediately process.

#### **MFR\_COMMON Data Contents**

BIT(S)	SYMBOL	OPERATION
b[7]	Mfr_common_alertb	Returns alert status. 1: ALERTB is de-asserted high. 0: ALERTB is asserted low.
b[6]	Mfr_common_busyb	Returns device busy status. 1: The device is available to process PMBus commands. 0: The device is busy and will NACK PMBus commands.
b[5:2]	Reserved	Read only, always returns 1s
b[1]	Mfr_common_share_clk	Returns status of share-clock pin 1: Share-clock pin is being held low 0: Share-clock pin is active
b[0]	Mfr_common_write_protect	Returns status of write-protect pin 1: Write-protect pin is high 0: Write-protect pin is low

## PMBus COMMAND DESCRIPTION

### *USER\_DATA\_00, USER\_DATA\_01, USER\_DATA\_02, USER\_DATA\_03, USER\_DATA\_04, MFR\_LTC\_RESERVED\_1 and MFR\_LTC\_RESERVED\_2*

These registers are provided as user scratchpad and additional manufacturer reserved locations.

USER\_DATA\_00, USER\_DATA\_01, MFR\_LTC\_RESERVED\_1 and MFR\_LTC\_RESERVED\_2 are all reserved for manufacturer use. Such uses include manufacturer traceability information and LTpowerPlay features like the CRC calculation and storage for user EEPROM configurations.

USER\_DATA\_02 is reserved for OEM use. These 2 bytes might be used for OEM traceability or revision information.

USER\_DATA\_03 and USER\_DATA\_04 are available for user scratchpad use. These 18 bytes (1 unpagged word plus 8 pagged words) might be used for traceability or revision information such as serial number, board model number, assembly location, or assembly date.

All user and OEM scratchpad registers may be stored and recalled from EEPROM using the STORE\_USER\_ALL and RESTORE\_USER\_ALL commands.

### ***MFR\_VOUT\_MIN***

This command returns the minimum ADC measured value of the channel's output voltage. This register is reset to 0xFFFF (7.999) when the LTC2977 emerges from power-on reset, when a CLEAR\_FAULTS command to the page is executed, or the channel goes through an off-to-on transition. When odd channels are configured to measure current, this command is not supported. Updates are disabled when undervoltage detection is disabled, such as when Margin Low (Ignore Faults and Warnings) is enabled.

#### **MFR\_VOUT\_MIN Data Contents**

BIT(S)	SYMBOL	OPERATION
b[15:0]	Mfr_vout_min	The data uses the L16 format. Units: V.

### ***MFR\_VIN\_MIN***

This command returns the minimum ADC measured value of the input voltage. This register is reset to 0x7BFF (approximately  $2^{25}$ ) when the LTC2977 emerges from power-on reset, when a CLEAR\_FAULTS command to any page is executed, or a channel goes through an off-to-on transition. Updates are disabled when unit is off for insufficient input voltage.

#### **MFR\_VIN\_MIN Data Contents**

BIT(S)	SYMBOL	OPERATION
b[15:0]	Mfr_vin_min	The data uses the L11 format. Units: V.

## PMBus COMMAND DESCRIPTION

### MFR\_TEMPERATURE\_MIN

This command returns the minimum ADC measured value of junction temperature in °C as determined by the LTC2977's internal temperature sensor. This register is reset to 0x7BFF (approximately 2<sup>25</sup>) when the LTC2977 emerges from power-on reset, when a CLEAR\_FAULTS command to any page is executed, or a channel goes through an off-to-on transition.

#### MFR\_TEMPERATURE\_MIN Data Contents

BIT(S)	SYMBOL	OPERATION
b[15:0]	Mfr_temperature_min	The data uses the L11 format. Units: °C.

### MFR\_STATUS\_2

This command returns additional manufacturer specific fault and state information. Bits marked Sticky = Yes are set by the appropriate event and not cleared until the user issues a CLEAR\_FAULTS command or turns the channel back on. Bits marked ALERT = Yes assert ALERTB low when they are set. Bits marked Channel = All are not paged.

#### MFR\_STATUS\_2 Data Contents

BIT(S)	SYMBOL	OPERATION	STICKY	ALERT	CHANNEL
b[15:3]	Reserved	Read only, always returns 0s.			
b[2]	Mfr_status_2_short_cycle_fault	1: This channel was commanded on by user before it finished sequencing off. 0: No short cycle fault has occurred for this channel.	Yes	Yes	Current Page
b[1]	Mfr_status_2_vinen_drive	1: VIN_EN pad is being driven low by this chip. 0: VIN_EN pad is not being driven low by this chip.	No	No	All
b[0]	Mfr_status_2_vin_caused_off	1: This channel was turned off due to VIN_SNS dropping below the VIN_OFF threshold. 0: VIN_SNS has not caused this channel to turn off.	Yes	No	Current Page

Short cycle fault detection is used to prevent out-of-order on sequencing when the user issues an ON command too soon after an OFF command. If some channels are still finishing OFF delays when the early ON command is received, they might turn back on too late. This fault should be propagated to all channels in the sequence to ensure a clean ON sequence. When a channel detects a short cycle fault it sets Mfr\_status\_2\_short\_cycle\_fault, Status\_word\_mfr, Status\_word\_high\_byte, and pulls ALERTB low. It also faults off, and stays off until the user issues an OFF-THEN-ON sequence or resets the part. Fault retries are not supported for short cycle faults.

Mfr\_status\_2\_vinen\_drive indicates the current status of this chip's VIN\_EN pad driver. It is not affected by CLEAR\_FAULTS commands, and no other status bits are affected when it is set.

Mfr\_status\_2\_vin\_caused\_off indicates that this channel was turned off because VIN\_SNS dropped below the VIN\_OFF threshold. Status\_word\_mfr and Status\_word\_high\_byte are set at the same time, but ALERTB is not asserted. If VIN\_SNS subsequently rises above VIN\_ON, and this channel turns back on, Mfr\_status\_2\_vin\_caused\_off will remain asserted to record the transient event regardless of the value of Mfr\_config\_all\_vin\_on\_clr\_faults\_en.

## PMBus COMMAND DESCRIPTION

### MFR\_TELEMETRY

This read-only command enables efficient polling of telemetry data for all output channels via a single 49 byte block read.

#### MFR\_TELEMETRY Data Block Contents

DATA	BYTE*
Status_word0[7:0]	0
Status_word0[15:8]	1
Status_vout0	2
Status_mfr0	3
Read_vout0[7:0]	4
Read_vout0[15:8]	5
Status_word1[7:0]	6
Status_word1[15:8]	7
Status_vout1	8
Status_mfr1	9
Read_vout1[7:0]	10
Read_vout1[15:8]	11
Status_word2[7:0]	12
Status_word2[15:8]	13
Status_vout2	14
Status_mfr2	15
Read_vout2[7:0]	16
Read_vout2[15:8]	17
Status_word3[7:0]	18
Status_word3[15:8]	19
Status_vout3	20
Status_mfr3	21

Read_vout3[7:0]	22
Read_vout3[15:8]	23
Status_word4[7:0]	24
Status_word4[15:8]	25
Status_vout4	26
Status_mfr4	27
Read_vout4[7:0]	28
Read_vout4[15:8]	29
Status_word5[7:0]	30
Status_word5[15:8]	31
Status_vout5	32
Status_mfr5	33
Read_vout5[7:0]	34
Read_vout5[15:8]	35
Status_word6[7:0]	36
Status_word6[15:8]	37
Status_vout6	38
Status_mfr6	39
Read_vout6[7:0]	40
Read_vout6[15:8]	41
Status_word7[7:0]	42
Status_word7[15:8]	43
Status_vout7	44
Status_mfr7	45
Read_vout7[7:0]	46
Read_vout7[15:8]	47
Reserved	48

\*Note: PMBus data byte numbers start at 1 rather than 0. Status\_word0[7:0] is the first byte returned after BYTE COUNT = 0x31. See block read protocol.

## PMBus COMMAND DESCRIPTION

### WATCHDOG OPERATION

A non zero write to the MFR\_WATCHDOG\_T register will reset the watchdog timer. Low-to-high transitions on the WDI/RESETB pin also reset the watchdog timer. If the timer expires, ALERTB is asserted and the PWRGD output is optionally deasserted and then reasserted after MFR\_PWRGD\_ASSERTION\_DELAY ms. Writing 0 to either the MFR\_WATCH\_DOG\_T or MFR\_WATCHDOG\_T\_FIRST registers will disable the timer.

#### ***MFR\_WATCHDOG\_T\_FIRST and MFR\_WATCHDOG\_T***

The MFR\_WATCHDOG\_T\_FIRST register allows the user to program the duration of the first watchdog timer interval following assertion of the PWRGD pin, assuming the PWRGD signal reflects the status of the watchdog timer. If assertion of PWRGD is not conditioned by the watchdog timer's status, then MFR\_WATCHDOG\_T\_FIRST applies to the first timing interval after the timer is enabled. Writing a value of 0ms to the MFR\_WATCHDOG\_T\_FIRST register disables the watchdog timer.

The MFR\_WATCHDOG\_T register allows the user to program watchdog time intervals subsequent to the MFR\_WATCHDOG\_T\_FIRST timing interval. Writing a value of 0ms to the MFR\_WATCHDOG\_T register disables the watchdog timer. A non-zero write to MFR\_WATCHDOG\_T will reset the watchdog timer.

The read value of both commands always returns what was last written and does not reflect internal limiting.

#### **MFR\_WATCHDOG\_T\_POR and MFR\_WATCHDOG\_T Data Contents**

BIT(S)	SYMBOL	OPERATION
b[15:0]	Mfr_watchdog_t_first Mfr_watchdog_t	The data uses the L11 format. These timers operate on an internal clock. The Mfr_watchdog_t timer will align to SHARE_CLK if it is running. Delays are rounded to the nearest 10µs for _t and 1ms for _t_first. Writing a zero value for Y to the Mfr_watchdog_t or Mfr_watchdog_t_first registers will disable the watchdog timer. Units: ms. Max timeout is 0.6 sec for _t and 65 sec for _t_first

### BULK PROGRAMMING THE USER EEPROM SPACE

The MFR\_EE\_UNLOCK, MFR\_EE\_ERASE and MFR\_EE\_DATA commands provide a method for 3rd party EEPROM programming houses and end users to easily program the LTC2977 independent of any order dependencies or delays between PMBus commands. All data transfers are directly to and from the EEPROM and do not affect the volatile RAM space currently configuring the device.

The first step is to program a master reference part with the desired configuration. MFR\_EE\_UNLOCK and MFR\_EE\_DATA are then used to read back all the data in User EEPROM space as sequential words. This information is stored to the master programming HEX file. Subsequent parts may be cloned to match the master part using MFR\_EE\_UNLOCK, MFR\_EE\_ERASE and MFR\_EE\_DATA to transfer data from the master HEX file. These commands operate directly on the EEPROM independent of the part configurations stored in RAM space. During EEPROM access the part will indicate that it is busy as described below.

In order to support simple programming fixtures the bulk programming feature only uses PMBus word and byte commands. The MFR\_EE\_UNLOCK configures the appropriate access mode and resets an internal address pointer allowing a series of word commands to behave as a block read or write with the address pointer being incremented after each operation. PEC use is optional and is configured by the MFR\_EE\_UNLOCK operation.

## PMBus COMMAND DESCRIPTION

### ***MFR\_EE\_UNLOCK***

The MFR\_EE\_UNLOCK command prevents accidental EEPROM access in normal operation and configures the required EEPROM bulk programming mode for bulk initialization, sequential writes, or reads. MFR\_EE\_UNLOCK augments the protection provided by write protect. Upon unlocking the part for the required operation, an internal address pointer is reset allowing a series of MFR\_EE\_DATA reads or writes to sequentially transfer data, similar to a block read or block write. The MFR\_EE\_UNLOCK command can clear or set PEC mode based on the desired level of error protection. An MFR\_EE\_UNLOCK sequence consists of writing two or three unlock codes as described below. The following table documents the allowed sequences. Writing a non-supported sequence locks the part. Reading MFR\_EE\_UNLOCK returns the last byte written or zero if the part is locked.

#### **MFR\_EE\_UNLOCK Data Contents**

BIT(S)	SYMBOL	OPERATION
b[7:0]	Mfr_ee_unlock[7:0]	<p>To unlock user EEPROM space for Mfr_ee_erase and Mfr_ee_data read or write operations with PEC allowed: Write 0x2b followed by 0xd4.</p> <p>To unlock user EEPROM space for Mfr_ee_erase and Mfr_ee_data read or write operations with PEC required: Write 0x2b followed by 0xd5.</p> <p>To unlock user and manufacturer EEPROM space for Mfr_ee_data read only operations with PEC allowed: Write 0x2b, followed by 0x91 followed by 0xe4.</p> <p>To unlock user and manufacturer EEPROM space for Mfr_ee_data read only operations with PEC required: Write 0x2b, followed by 0x91 followed by 0xe5.</p>

### ***MFR\_EE\_ERASE***

The MFR\_EE\_ERASE command is used to erase the entire contents of the user EEPROM space and configures this space to accept new program data. Writing values other than 0x2B will lock the part. Reads return the last value written.

#### **MFR\_EE\_ERASE Data contents**

BIT(S)	SYMBOL	OPERATION
b[7:0]	Mfr_ee_erase[7:0]	<p>To erase the user EEPROM space and configure to accept new data:</p> <ol style="list-style-type: none"> <li>1) Use the appropriate Mfr_ee_unlock sequence to configure for Mfr_ee_erase commands with or without PEC.</li> <li>2) Write 0x2B to Mfr_ee_erase.</li> </ol> <p>The part will indicate it is busy erasing the EEPROM by the mechanism detailed below.</p>

### ***MFR\_EE\_DATA***

The MFR\_EE\_DATA command allows the user to transfer data directly to or from the EEPROM without affecting RAM space.

To read the user EEPROM space issue the appropriate Mfr\_ee\_unlock command and perform Mfr\_ee\_data reads until the EEPROM has been completely read. Extra reads will lock the part and return zero. The first read returns the 16-bit EEPROM packing revision ID that is stored in ROM. The second read returns the number of 16-bit words available; this is the number of reads or writes to access all memory locations. Subsequent reads return EEPROM data starting with the lowest address.

To write to the user EEPROM space issue, the appropriate Mfr\_ee\_unlock and Mfr\_ee\_erase commands followed by successive Mfr\_ee\_data word writes until the EEPROM is full. Extra writes will lock the part. The first write is to the lowest address.

Mfr\_ee\_data reads and writes must not be mixed.

## PMBus COMMAND DESCRIPTION

### MFR\_EE\_DATA Data Contents

BIT(S)	SYMBOL	OPERATION
b[15:0]	Mfr_ee_data[15:0]	<p>To read user space</p> <ol style="list-style-type: none"> <li>1) Use the appropriate Mfr_ee_unlock sequence to configure for Mfr_ee_data commands with or without PEC.</li> <li>2) Read Mfr_ee_data[0] = PackingId (MFR Specific ID).</li> <li>3) Read Mfr_ee_data[1] = NumberOfUserWords (total number of 16-bit word available).</li> <li>4) Read Mfr_ee_data[2] through Mfr_ee_data[NumberOfUserWords+1] (User EEPROM data contents)</li> </ol> <p>To write user space</p> <ol style="list-style-type: none"> <li>1) Initialize the user memory using the sequence described for the MFR_EE_ERASE command.</li> <li>2) Use the appropriate Mfr_ee_unlock sequence to configure for Mfr_ee_data commands with or without PEC.</li> <li>3) Write Mfr_ee_data[0] through Mfr_ee_data[NumberOfUserWords-1] (User EEPROM data content to be written)</li> </ol> <p>The part will indicate it is busy erasing the EEPROM by the mechanism detailed below.</p>

### Response When Part Is Busy

The part will indicate it is busy accessing the EEPROM by:

- 1) Asserting low the Mfr\_common\_busyb of the MFR\_COMMON register. This byte can always be read and will never NACK a byte read request even if the part is busy.
- 2) NACKing commands other than MFR\_COMMON.
- 3) Asserting ALERTB low if any commands other than MFR\_COMMON are issued.

### MFR\_EE Erase and Write Programming Time

The program time per word is typically 0.17ms and will require spacing the I<sup>2</sup>C/SMBus writes at greater than 0.17ms to guarantee the write has completed. The Mfr\_ee\_erase command takes approximately 400ms. We recommend using MFR\_COMMON for handshaking.

### FAULT LOG OPERATION

A conceptual diagram of the fault log is shown in Figure 14. The fault log provides black box capability to the LTC2977. During normal operation the contents of the status registers, the output voltage readings, temperature readings as well as peak and min values of these quantities are stored in a continuously updated buffer in RAM. You can think of the operation as being similar to a strip chart recorder. When a fault occurs, the contents are written into EEPROM for nonvolatile storage. The EEPROM fault log is then locked. The part can be powered down with the fault log available for reading at a later time.

### *MFR\_FAULT\_LOG\_STORE*

This command allows the user to transfer data from the RAM buffer to EEPROM.

### *MFR\_FAULT\_LOG\_RESTORE*

This command allows the user to transfer a copy of the fault-log data from the EEPROM to the RAM buffer. After a restore the RAM buffer is locked until a successful MFR\_FAULT\_LOG read or MFR\_FAULT\_LOG\_CLEAR.

## PMBus COMMAND DESCRIPTION

### MFR\_FAULT\_LOG\_CLEAR

This command initializes the EEPROM block reserved for fault logging. Any previous fault log stored in EEPROM will be erased by this operation and logging of the fault log RAM to EEPROM will be enabled.

### MFR\_FAULT\_LOG\_STATUS

Read only. This register is used to manage fault log events.

Mfr\_fault\_log\_status\_eeprom is set after a MFR\_FAULT\_LOG\_STORE command or a faulted-off event triggers a transfer of the fault log from RAM to EEPROM. This bit is cleared by a MFR\_FAULT\_LOG\_CLEAR command.

Mfr\_fault\_log\_status\_ram is set after a MFR\_FAULT\_LOG\_RESTORE to indicate that the data in the RAM has been restored from EEPROM and not yet read using a MFR\_FAULT\_LOG command. This bit is cleared by a successful execution of an MFR\_FAULT\_LOG command, or by a successful execution of an MFR\_FAULT\_LOG\_CLEAR command.

#### MFR\_FAULT\_LOG\_STATUS Data Contents

BIT(S)	SYMBOL	OPERATION
b[1]	Mfr_fault_log_status_ram	Fault log RAM status: 0: The fault log RAM allows updates. 1: The fault log RAM is locked until the next MFR_FAULT_LOG read.
b[0]	Mfr_fault_log_status_eeprom	Fault log EEPROM status: 0: The transfer of the fault log RAM to the EEPROM is enabled. 1: The transfer of the fault log RAM to the EEPROM is inhibited.

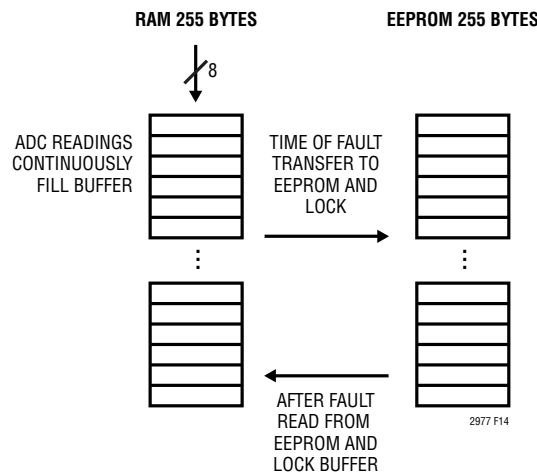


Figure 14. Fault Log Conceptual Diagram

---

## PMBus COMMAND DESCRIPTION

### ***MFR\_FAULT\_LOG***

Read only. This 2040-bit (255 byte) data block contains a copy of the RAM buffer fault log. The RAM buffer is continuously updated after each ADC conversion as long as `Mfr_fault_log_status_ram` is clear.

With `Mfr_config_all_fault_log_enable = 1` and `Mfr_fault_log_status_eeprom = 0`, the RAM buffer is transferred to EEPROM whenever an LTC2977 fault causes a channel to latch off or a `MFR_FAULT_LOG_STORE` command is received. This transfer is delayed until the ADC has updated its READ values for all channels when `Mfr_config_all_fast_fault_log` is clear, otherwise it happens within 24ms. This optional delay can be used to ensure that the slower, ADC monitored, values are all updated for the case where a fast supervisor detected fault initiates the transfer to EEPROM.

`Mfr_fault_log_status_eeprom` is set high after the RAM buffer is transferred to EEPROM and not cleared until a `MFR_FAULT_LOG_CLEAR` is received, even if the LTC2977 is reset or powered down. Fault log EEPROM transfers are not initiated as a result of `Status_mfr_discharge` events.

During a `MFR_FAULT_LOG` read, data is returned as defined by the following table. The fault log data is partitioned into two sections. The first section is referred to as the preamble and contains the Position-last pointer, time information and peak and minimum values. The second section contains a chronological record of telemetry and requires Position-last for proper interpretation. The fault log stores approximately 0.5 seconds of telemetry. To prevent timeouts during block reads, it is recommended that `Mfr_config_all_longer_pmbus_timeout` be set to 1.

## PMBus COMMAND DESCRIPTION

Table 4. Data Block Contents

DATA	BYTE*	DESCRIPTION
Position_last[7:0]	0	Position of fault log pointer when fault occurred.
Cyclic_data_valid_count[7:0]	1	Number of valid bytes of cyclic data. 0xFF indicates all cyclic data is valid.
SharedTime[7:0]	2	41-bit share-clock counter value when fault occurred. Counter LSB is in 200µs increments. This counter is cleared at power-up or after the LTC2977 is reset
SharedTime[15:8]	3	
SharedTime[23:16]	4	
SharedTime[31:24]	5	
SharedTime[39:32]	6	
SharedTime[40]	7	
Mfr_vout_peak0[7:0]	8	
Mfr_vout_peak0[15:8]	9	
Mfr_vout_min0[7:0]	10	
Mfr_vout_min0[15:8]	11	
Mfr_vout_peak1[7:0]	12	
Mfr_vout_peak1[15:8]	13	
Mfr_vout_min1[7:0]	14	
Mfr_vout_min1[15:8]	15	
Mfr_vin_peak[7:0]	16	
Mfr_vin_peak[15:8]	17	
Mfr_vin_min[7:0]	18	
Mfr_vin_min[15:8]	19	
Mfr_vout_peak2[7:0]	20	
Mfr_vout_peak2[15:8]	21	
Mfr_vout_min2[7:0]	22	
Mfr_vout_min2[15:8]	23	
Mfr_vout_peak3[7:0]	24	
Mfr_vout_peak3[15:8]	25	
Mfr_vout_min3[7:0]	26	
Mfr_vout_min3[15:8]	27	
Mfr_temp_peak[7:0]	28	
Mfr_temp_peak[15:8]	29	
Mfr_temp_min[7:0]	30	
Mfr_temp_min[15:8]	31	
Mfr_vout_peak4[7:0]	32	
Mfr_vout_peak4[15:8]	33	
Mfr_vout_min4[7:0]	34	
Mfr_vout_min4[15:8]	35	
Mfr_vout_peak5[7:0]	36	
Mfr_vout_peak5[15:8]	37	
Mfr_vout_min5[7:0]	38	
Mfr_vout_min5[15:8]	39	

Table 4. Data Block Contents

DATA	BYTE*	DESCRIPTION
Mfr_vout_peak6[7:0]	40	
Mfr_vout_peak6[15:8]	41	
Mfr_vout_min6[7:0]	42	
Mfr_vout_min6[15:8]	43	
Mfr_vout_peak7[7:0]	44	
Mfr_vout_peak7[15:8]	45	
Mfr_vout_min7[7:0]	46	
Mfr_vout_min7[15:8]	47	
Status_vout0	48	
Status_mfr0	49	
Mfr_status_2_0[7:0]	50	Reserved bits[15:8] not stored
Status_vout1	51	
Status_mfr1	52	
Mfr_status_2_1[7:0]	53	
Status_vout2	54	
Status_mfr2	55	
Mfr_status_2_2[7:0]	56	
Status_vout3	57	
Status_mfr3	58	
Mfr_status_2_3[7:0]	59	
Status_vout4	60	
Status_mfr4	61	
Mfr_status_2_4[7:0]	62	
Status_vout5	63	
Status_mfr5	64	
Mfr_status_2_5[7:0]	65	
Status_vout6	66	
Status_mfr6	67	
Mfr_status_2_6[7:0]	68	
Status_vout7	69	
Status_mfr7	70	
Mfr_status_2_7[7:0]	71	
		72 bytes for preamble
Fault_log [Position_last]	72	Start of cyclic data
Fault_log	73	
.		
.		
.		
Fault_log	237	Last Valid Byte
Reserved	238-254	

Number of cyclic data loops:  $(238-72)/46 = 3.6$

\* Note: PMBus data byte numbers start at 1 rather than 0. Position\_last is the first byte returned after BYTE COUNT = 0xFF. See block read protocol.

## PMBus COMMAND DESCRIPTION

The data returned between bytes 72 and 237 of the previous table is interpreted using Position\_last and the following table. The key to identifying byte 72 is to locate the DATA corresponding to POSITION = Position\_last in the next table. Subsequent bytes are identified by decrementing the value of POSITION. For example: If Position\_last = 11 then the first data returned in byte position 72 of a block read is Read\_vin[15:8] followed by Read\_vin[7:0] followed by Mfr\_status\_2 of page 1. See Table 5.

**Table 5. Interpreting Cyclical Loop**

POSITION	DATA
0	Read_vout0[7:0]
1	Read_vout0[15:8]
2	Status_vout0
3	Status_mfr0
4	Mfr_status_2_0[7:0]
5	Read_vout1[7:0]
6	Read_vout1[15:8]
7	Status_vout1
8	Status_mfr1
9	Mfr_status_2_1[7:0]
10	Read_vin[7:0]
11	Read_vin[15:8]
12	Status_vin
13	Read_vout2[7:0]
14	Read_vout2[15:8]
15	Status_vout2
16	Status_mfr2
17	Mfr_status_2_2[7:0]
18	Read_vout3[7:0]
19	Read_vout3[15:8]
20	Status_vout3
21	Status_mfr3
22	Mfr_status_2_3[7:0]
23	Read_temperature_1[7:0]
24	Read_temperature_1[15:8]
25	Status_temp
26	Read_vout4[7:0]
27	Read_vout4[15:8]
28	Status_vout4
29	Status_mfr4
30	Mfr_status_2_4[7:0]
31	Read_vout5[7:0]
32	Read_vout5[15:8]
33	Status_vout5

**Table 5. Interpreting Cyclical Loop**

POSITION	DATA
34	Status_mfr5
35	Mfr_status_2_5[7:0]
36	Read_vout6[7:0]
37	Read_vout6[15:8]
38	Status_vout6
39	Status_mfr6
40	Mfr_status_2_6[7:0]
41	Read_vout7[7:0]
42	Read_vout7[15:8]
43	Status_vout7
44	Status_mfr7
45	Mfr_status_2_7[7:0]
Total Bytes = 46	

The following table fully decodes a sample fault log read to help clarify the cyclical nature of the operation.

**MFR\_FAULT\_LOG DATA BLOCK CONTENTS**

PREAMBLE INFORMATION				
BYTE NUMBER DECIMAL	BYTE NUMBER HEX		DATA	DESCRIPTION
0	00		Position_last[7:0] = 11	Position of Fault-Log Pointer When Fault Occurred.
1	01		Cyclic_data_valid_count[7:0] = 160	Final 6 Bytes Of Cyclic Data Not Valid
2	02		SharedTime[7:0]	41-Bit Share-Clock Counter Value When Fault Occurred. Counter LSB Is in 200µs Increments.
3	03		SharedTime[15:8]	
4	04		SharedTime[23:16]	
5	05		SharedTime[31:24]	
6	06		SharedTime[39:32]	
7	07		SharedTime[40]	
8	08		Mfr_vout_peak0[7:0]	
9	09		Mfr_vout_peak0[15:8]	
10	0A		Mfr_vout_min0[7:0]	
11	0B		Mfr_vout_min0[15:8]	
12	0C		Mfr_vout_peak1[7:0]	
13	0D		Mfr_vout_peak1[15:8]	
14	0E		Mfr_vout_min1[7:0]	
15	0F		Mfr_vout_min1[15:8]	

## PMBus COMMAND DESCRIPTION

BYTE NUMBER DECIMAL	BYTE NUMBER HEX	DATA	DESCRIPTION
16	10	Mfr_vin_peak[7:0]	
17	11	Mfr_vin_peak[15:8]	
18	12	Mfr_vin_min[7:0]	
19	13	Mfr_vin_min[15:8]	
20	14	Mfr_vout_peak2[7:0]	
21	15	Mfr_vout_peak2[15:8]	
22	16	Mfr_vout_min2[7:0]	
23	17	Mfr_vout_min2[15:8]	
24	18	Mfr_vout_peak3[7:0]	
25	19	Mfr_vout_peak3[15:8]	
26	1A	Mfr_vout_min3[7:0]	
27	1B	Mfr_vout_min3[15:8]	
28	1C	Mfr_temp_peak[7:0]	
29	1D	Mfr_temp_peak[15:8]	
30	1E	Mfr_temp_min[7:0]	
31	1F	Mfr_temp_min[15:8]	
32	20	Mfr_vout_peak4[7:0]	
33	21	Mfr_vout_peak4[15:8]	
34	22	Mfr_vout_min4[7:0]	
35	23	Mfr_vout_min4[15:8]	
36	24	Mfr_vout_peak5[7:0]	
37	25	Mfr_vout_peak5[15:8]	
38	26	Mfr_vout_min5[7:0]	
39	27	Mfr_vout_min5[15:8]	
40	28	Mfr_vout_peak6[7:0]	
41	29	Mfr_vout_peak6[15:8]	
42	2A	Mfr_vout_min6[7:0]	
43	2B	Mfr_vout_min6[15:8]	
44	2C	Mfr_vout_peak7[7:0]	
45	2D	Mfr_vout_peak7[15:8]	
46	2E	Mfr_vout_min7[7:0]	
47	2F	Mfr_vout_min7[15:8]	
48	30	Status_vout0	
49	31	Status_mfr0	
50	32	Mfr_status_2_0[7:0]	
51	33	Status_vout1	

BYTE NUMBER DECIMAL	BYTE NUMBER HEX	DATA	DESCRIPTION
52	34	Status_mfr1	
53	35	Mfr_status_2_1[7:0]	
54	36	Status_vout2	
55	37	Status_mfr2	
56	38	Mfr_status_2_2[7:0]	
57	39	Status_vout3	
58	3A	Status_mfr3	
59	3B	Mfr_status_2_3[7:0]	
60	3C	Status_vout4	
61	3D	Status_mfr4	
62	3E	Mfr_status_2_4[7:0]	
63	3F	Status_vout5	
64	40	Status_mfr5	
65	41	Mfr_status_2_5[7:0]	
66	42	Status_vout6	
67	43	Status_mfr6	
68	44	Mfr_status_2_6[7:0]	
69	45	Status_vout7	
70	46	Status_mfr7	
71	47	Mfr_status_2_7[7:0]	End of Preamble

### CYCLICAL DATA LOOPS

BYTE NUMBER DECIMAL	BYTE NUMBER HEX	LOOP BYTE NUMBER DECIMAL	DATA LOOP 0	46 BYTES PER LOOP
72	48	11	Read_vin[15:8]	Position_last
73	49	10	Read_vin[7:0]	
74	4A	9	Mfr_status_2_1[7:0]	
75	4B	8	Status_mfr1	
76	4C	7	Status_vout1	
77	4D	6	Read_vout1[15:8]	
78	4E	5	Read_vout1[7:0]	
79	4F	4	Mfr_status_2_0[7:0]	
80	50	3	Status_mfr0	
81	51	2	Status_vout0	
82	52	1	Read_vout0[15:8]	
83	53	0	Read_vout0[7:0]	

## PMBus COMMAND DESCRIPTION

BYTE NUMBER DECIMAL	BYTE NUMBER HEX	LOOP BYTE NUMBER DECIMAL	DATA LOOP 1	46 BYTES PER LOOP
84	54	45	Mfr_status_2_7[7:0]	
85	55	44	Status_mfr7	
86	56	43	Status_vout7	
87	57	42	Read_vout7[15:8]	
88	58	41	Read_vout7[7:0]	
89	59	40	Mfr_status_2_6[7:0]	
90	5A	39	Status_mfr6	
91	5B	38	Status_vout6	
92	5C	37	Read_vout6[15:8]	
93	5D	36	Read_vout6[7:0]	
94	5E	35	Mfr_status_2_5[7:0]	
95	5F	34	Status_mfr5	
96	60	33	Status_vout5	
97	61	32	Read_vout5[15:8]	
98	62	31	Read_vout5[7:0]	
99	63	30	Mfr_status_2_4[7:0]	
100	64	29	Status_mfr4	
101	65	28	Status_vout4	
102	66	27	Read_vout4[15:8]	
103	67	26	Read_vout4[7:0]	
104	68	25	Status_temp	
105	69	24	Read_temperature_1[15:8]	
106	6A	23	Read_temperature_1[7:0]	
107	6B	22	Mfr_status_2_3[7:0]	
108	6C	21	Status_mfr3	
109	6D	20	Status_vout3	
110	6E	19	Read_vout3[15:8]	
111	6F	18	Read_vout3[7:0]	
112	70	17	Mfr_status_2_2[7:0]	
113	71	16	Status_mfr2	
114	72	15	Status_vout2	
115	73	14	Read_vout2[15:8]	
116	74	13	Read_vout2[7:0]	
117	75	12	Status_vin	
118	76	11	Read_vin[15:8]	

BYTE NUMBER DECIMAL	BYTE NUMBER HEX	LOOP BYTE NUMBER DECIMAL	DATA LOOP 1	46 BYTES PER LOOP
119	77	10	Read_vin[7:0]	
120	78	9	Mfr_status_2_1[7:0]	
121	79	8	Status_mfr1	
122	7A	7	Status_vout1	
123	7B	6	Read_vout1[15:8]	
124	7C	5	Read_vout1[7:0]	
125	7D	4	Mfr_status_2_0[7:0]	
126	7E	3	Status_mfr0	
127	7F	2	Status_vout0	
128	80	1	Read_vout0[15:8]	
129	81	0	Read_vout0[7:0]	

BYTE NUMBER DECIMAL	BYTE NUMBER HEX	LOOP BYTE NUMBER DECIMAL	DATA LOOP 2	46 BYTES PER LOOP
130	82	45	Mfr_status_2_7[7:0]	
131	83	44	Status_mfr7	
132	84	43	Status_vout7	
133	85	42	Read_vout7[15:8]	
134	86	41	Read_vout7[7:0]	
135	87	40	Mfr_status_2_6[7:0]	
136	88	39	Status_mfr6	
137	89	38	Status_vout6	
138	8A	37	Read_vout6[15:8]	
139	8B	36	Read_vout6[7:0]	
140	8C	35	Mfr_status_2_5[7:0]	
141	8D	34	Status_mfr5	
142	8E	33	Status_vout5	
143	8F	32	Read_vout5[15:8]	
144	90	31	Read_vout5[7:0]	
145	91	30	Mfr_status_2_4[7:0]	
146	92	29	Status_mfr4	
147	93	28	Status_vout4	
148	94	27	Read_vout4[15:8]	
149	95	26	Read_vout4[7:0]	
150	96	25	Status_temp	

## PMBus COMMAND DESCRIPTION

BYTE NUMBER DECIMAL	BYTE NUMBER HEX	LOOP BYTE NUMBER DECIMAL	DATA LOOP 2	46 BYTES PER LOOP
151	97	24	Read_temperature_1[15:8]	
152	98	23	Read_temperature_1[7:0]	
153	99	22	Mfr_status_2_3[7:0]	
154	9A	21	Status_mfr3	
155	9B	20	Status_vout3	
156	9C	19	Read_vout3[15:8]	
157	9D	18	Read_vout3[7:0]	
158	9E	17	Mfr_status_2_2[7:0]	
159	9F	16	Status_mfr2	
160	A0	15	Status_vout2	
161	A1	14	Read_vout2[15:8]	
162	A2	13	Read_vout2[7:0]	
163	A3	12	Status_vin	
164	A4	11	Read_vin[15:8]	
165	A5	10	Read_vin[7:0]	
166	A6	9	Mfr_status_2_1[7:0]	
167	A7	8	Status_mfr1	
168	A8	7	Status_vout1	
169	A9	6	Read_vout1[15:8]	
170	AA	5	Read_vout1[7:0]	
171	AB	4	Mfr_status_2_0[7:0]	
172	AC	3	Status_mfr0	
173	AD	2	Status_vout0	
174	AE	1	Read_vout0[15:8]	
175	AF	0	Read_vout0[7:0]	

BYTE NUMBER DECIMAL	BYTE NUMBER HEX	LOOP BYTE NUMBER DECIMAL	DATA LOOP 3	46 BYTES PER LOOP
176	B0	45	Mfr_status_2_7[7:0]	
177	B1	44	Status_mfr7	
178	B2	43	Status_vout7	
179	B3	42	Read_vout7[15:8]	
180	B4	41	Read_vout7[7:0]	
181	B5	40	Mfr_status_2_6[7:0]	

BYTE NUMBER DECIMAL	BYTE NUMBER HEX	LOOP BYTE NUMBER DECIMAL	DATA LOOP 3	46 BYTES PER LOOP
182	B6	39	Status_mfr6	
183	B7	38	Status_vout6	
184	B8	37	Read_vout6[15:8]	
185	B9	36	Read_vout6[7:0]	
186	BA	35	Mfr_status_2_5[7:0]	
187	BB	34	Status_mfr5	
188	BC	33	Status_vout5	
189	BD	32	Read_vout5[15:8]	
190	BE	31	Read_vout5[7:0]	
191	BF	30	Mfr_status_2_4[7:0]	
192	C0	29	Status_mfr4	
193	C1	28	Status_vout4	
194	C2	27	Read_vout4[15:8]	
195	C3	26	Read_vout4[7:0]	
196	C4	25	Status_temp	
197	C5	24	Read_temperature_1[15:8]	
198	C6	23	Read_temperature_1[7:0]	
199	C7	22	Mfr_status_2_3[7:0]	
200	C8	21	Status_mfr3	
201	C9	20	Status_vout3	
202	CA	19	Read_vout3[15:8]	
203	CB	18	Read_vout3[7:0]	
204	CC	17	Mfr_status_2_2[7:0]	
205	CD	16	Status_mfr2	
206	CE	15	Status_vout2	
207	CF	14	Read_vout2[15:8]	
208	D0	13	Read_vout2[7:0]	
209	D1	12	Status_vin	
210	D2	11	Read_vin[15:8]	
211	D3	10	Read_vin[7:0]	
212	D4	9	Mfr_status_2_1[7:0]	
213	D5	8	Status_mfr1	
214	D6	7	Status_vout1	
215	D7	6	Read_vout1[15:8]	
216	D8	5	Read_vout1[7:0]	

## PMBus COMMAND DESCRIPTION

BYTE NUMBER DECIMAL	BYTE NUMBER HEX	LOOP BYTE NUMBER DECIMAL	DATA LOOP 3	46 BYTES PER LOOP
217	D9	4	Mfr_status_2_0[7:0]	
218	DA	3	Status_mfr0	
219	DB	2	Status_vout0	
220	DC	1	Read_vout0[15:8]	
221	DD	0	Read_vout0[7:0]	

BYTE NUMBER DECIMAL	BYTE NUMBER HEX	LOOP BYTE NUMBER DECIMAL	DATA LOOP 4	46 BYTES PER LOOP
222	DE	45	Mfr_status_2_7[7:0]	
223	DF	44	Status_mfr7	
224	E0	43	Status_vout7	
225	E1	42	Read_vout7[15:8]	
226	E2	41	Read_vout7[7:0]	
227	E3	40	Mfr_status_2_6[7:0]	
228	E4	39	Status_mfr6	
229	E5	38	Status_vout6	
230	E6	37	Read_vout6[15:8]	
231	E7	36	Read_vout6[7:0]	
232	E8	35	Mfr_status_2_5[7:0]	Invalid data
233	E9	34	Status_mfr5	Invalid data
234	EA	33	Status_vout5	Invalid data
235	EB	32	Read_vout5[15:8]	Invalid data
236	EC	31	Read_vout5[7:0]	Invalid data
237	ED	30	Mfr_status_2_4[7:0]	Invalid data

RESERVED BYTES				
238	EE		0x00	Bytes EE - FE Return 0x00 But Must Be Read
239	EF		0x00	
240	F0		0x00	
241	F1		0x00	
242	F2		0x00	
243	F3		0x00	
244	F4		0x00	
245	F5		0x00	
246	F6		0x00	
247	F7		0x00	
248	F8		0x00	
249	F9		0x00	
250	FA		0x00	
251	FB		0x00	
252	FC		0x00	
253	FD		0x00	
254	FE		0x00	
				Use One Block Read Command to Read 255 Bytes Total, from 0x00 to 0xFE

## APPLICATIONS INFORMATION

### OVERVIEW

The LTC2977 is a power management IC that is capable of sequencing, margining, trimming, supervising output voltage for OV/UV conditions, providing fault management, and voltage readback for eight DC/DC converters. Input voltage and LTC2977 junction temperature readback are also available. Odd numbered channels can be configured to read back sense resistor voltages to provide current measurements for those channels. Analog Devices Power System Managers can coordinate operation among multiple devices using common SHARE\_CLK, FAULTB and CONTROL pins. The LTC2977 utilizes a PMBus compliant interface and command set.

### POWERING THE LTC2977

The LTC2977 can be powered two ways. The first method requires that a voltage between 4.5V and 15V be applied to the  $V_{PWR}$  pin. See Figure 15. An internal linear regulator converts  $V_{PWR}$  down to 3.3V which drives all of the internal circuitry of the LTC2977.

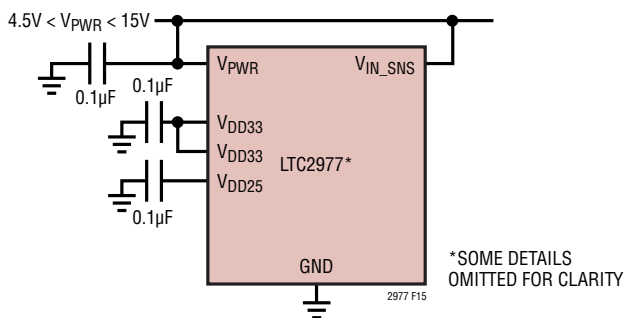


Figure 15. Powering LT2977 Directly from an Intermediate Bus

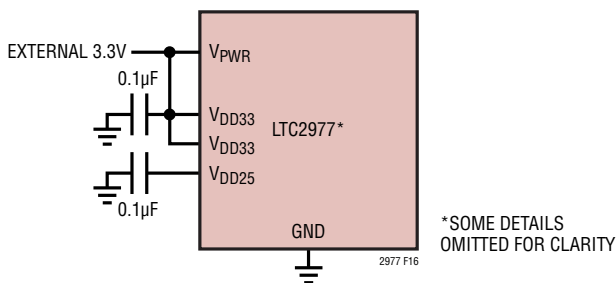


Figure 16. Powering LTC2977 from External 3.3V Supply

Alternatively, power from an external 3.3V supply may be applied directly to the  $V_{DD33}$  pins 16 and 17 using a voltage between 3.13V and 3.47V. Tie  $V_{PWR}$  to  $V_{DD33}$  pins. See Figure 16. All functionality is available when using this alternate power method. The higher voltages needed for the  $V_{OUT\_EN[3:0]}$  pins and bias for the  $V_{SENSE}$  pins are charge-pumped from  $V_{DD33}$ .

### SETTING COMMAND REGISTER VALUES

The command register settings described herein are intended as a reference and for the purpose of understanding the registers in a software development environment. In actual practice, the LTC2977 can be completely configured for standalone operation with the LTC USB to I<sup>2</sup>C/SMBus/PMBus controller (DC1613) and software GUI using intuitive menu driven objects.

### SEQUENCE, SERVO, MARGIN AND RESTART OPERATIONS

#### Command Units On or Off

Three control parameters determine how a particular channel is turned on and off. The CONTROL pins, the OPERATION command and the value of the input voltage measured at the  $V_{IN\_SNS}$  pin ( $V_{IN}$ ). In all cases,  $V_{IN}$  must exceed  $V_{IN\_ON}$  in order to enable the device to respond to the CONTROL pin or OPERATION command. When  $V_{IN}$  drops below  $V_{IN\_OFF}$  an immediate OFF or sequence off after  $TOFF\_DELAY$  of all channels will result (See  $Mfr\_config\_chan\_mode$ ). Refer to the Operation section in the data sheet for a detailed description of the  $ON\_OFF\_CONFIG$  command.

Some examples of typical ON/OFF configurations are:

1. A DC/DC converter may be configured to turn on anytime  $V_{IN}$  exceeds  $V_{IN\_ON}$ .
2. A DC/DC converter may be configured to turn on only when it receives an OPERATION command.
3. A DC/DC converter may be configured to turn on only via the CONTROL pin.
4. A DC/DC converter may be configured to turn on only when it receives an OPERATION command and the CONTROL pin is asserted.

## APPLICATIONS INFORMATION

### On Sequencing

The TON\_DELAY command sets the amount of time that a channel will wait following the start of an ON sequence before its V<sub>OUT\_EN</sub> pin will enable a DC/DC converter. Once the DC/DC converter has been enabled, the TON\_RISE value determines the time at which the device soft-connects the DAC and servos the DC/DC converter output to the V<sub>OUT\_COMMAND</sub> value. The TON\_MAX\_FAULT\_LIMIT value determines the time at which the device checks for an undervoltage condition. If a TON\_MAX\_FAULT occurs, the channel can be configured to disable the DC/DC converter and propagate the fault to other channels using the bidirectional FAULTB pins. Note that overvoltage faults are checked against the V<sub>OUT\_OV\_FAULT\_LIMIT</sub> at all times the device is powered up and not in a reset state nor margining while ignoring OVs. Figure 17 shows a typical on-sequence using the CONTROL pin.

### On State Operation

Once a channel has reached the ON state, the OPERATION command can be used to command the DC/DC converter's output to margin high, margin low, or return to a nominal output voltage indicated by V<sub>OUT\_COMMAND</sub>. The user also has the option of configuring a channel to continuously trim the output of the DC/DC converter to the V<sub>OUT\_COMMAND</sub> voltage, or the channel's V<sub>DACP<sub>n</sub></sub> output can be placed in a high impedance state thus allowing the DC/DC converter output voltage to go to its nominal value, V<sub>DC<sub>n</sub>(NOM)</sub>. Refer to the MFR\_CONFIG\_LTC2977 command for details on how to configure the output voltage servo.

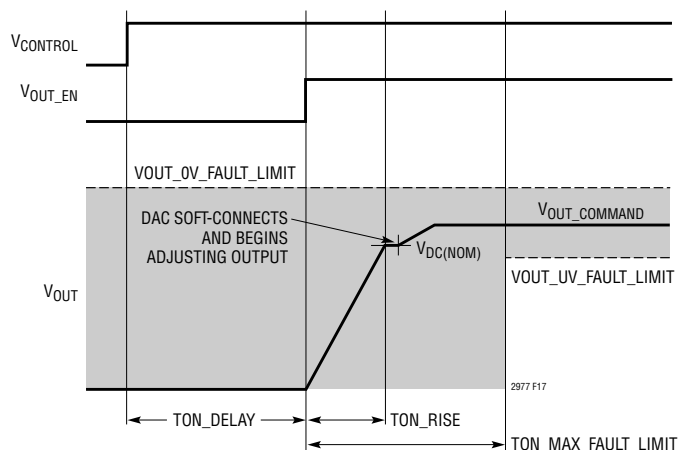


Figure 17. Typical On Sequence Using Control Pin

### Servo Modes

The ADC, DAC and internal processor comprise a digital servo loop that can be configured to operate in several useful modes. The servo target refers to the desired output voltage.

Continuous/noncontinuous trim mode. MFR\_CONFIG\_LTC2977 b[7]. In continuous trim mode, the servo will update the DAC in a closed loop fashion each time it takes a V<sub>OUT</sub> reading. The update rate is determined by the time it takes to step through the ADC MUX which is no more than t<sub>UPDATE\_ADC</sub>. See Electrical Characteristics Table Note 5. In noncontinuous trim mode, the servo will drive the DAC until the ADC measures the output voltage desired and then stop updating the DAC.

As part of continuous/noncontinuous trim mode, fast servo mode can be used to speed up large output transitions, such as margin commands, or ON events. To use, set Mfr\_config\_fast\_servo\_off=0. When enabled, fast servo is started by a change to the target voltage or a new soft-connect. The DAC is ramped one lsb every t<sub>S\_VDACP</sub> period until it is near the new target voltage, at which point slow servo mode is entered to avoid overshoot.

Noncontinuous servo on warn mode. MFR\_CONFIG\_LTC2977 b[7] = 0, b[6] = 1. When in noncontinuous mode, the LTC2977 will retrim (reservo) the output if the output drifts beyond the OV or UV warn limits.

### DAC Modes

The DACs that drive the V<sub>DACP<sub>n</sub></sub> pins can operate in several useful modes. See MFR\_CONFIG\_LTC2977.

- Soft-connect. Using the LTC patented soft-connect feature, the DAC output is driven to within 1 LSB of the voltage at the DC/DC's feedback node before connecting, to avoid introducing transients on the output. This mode is used when servoing the output voltage. During start-up, the LTC2977 waits until TON\_RISE has expired before connecting the DAC. This is the most common operating mode.
- Disconnected. DAC output is high Z.

## APPLICATIONS INFORMATION

- DAC manual with soft-connect. Non servo mode. The DAC soft-connects to the feedback node. Soft-connect drives the DAC code to match the voltage at the feedback node. After connection, the DAC is moved by writing DAC codes to the MFR\_DAC register.
- DAC manual with hard-connect. Non servo mode. The DAC hard-connects to the feedback node using the current value in MFR\_DAC. After connection, the DAC is moved by writing DAC codes to the MFR\_DAC register.

### Margining

The LTC2977 margins and trims the output of a DC/DC converter by forcing a voltage across an external resistor connected between the DAC output and the feedback node or the trim pin. Preset limits for margining are stored in the VOUT\_MARGIN\_HIGH/LOW registers. Margining is actuated by writing the appropriate bits to the OPERATION register.

Margining requires the DAC to be connected. Margin requests that occur when the DAC is disconnected will be ignored.

### Off Sequencing

An off sequence is initiated using the CONTROL pin or the OPERATION command. The TOFF\_DELAY value determines the amount of time that elapses from the beginning of the off sequence until each channel's VOUT\_EN pin is pulled low, thus disabling its DC/DC converter.

### V<sub>OUT</sub> Off Threshold Voltage

The MFR\_VOUT\_DISCHARGE\_THRESHOLD command register allows the user to specify the OFF threshold that the output voltage must decay below before the channel can enter/re-enter the ON state. The OFF threshold voltage is specified by multiplying MFR\_VOUT\_DISCHARGE\_THRESHOLD and VOUT\_COMMAND. In the event that an output voltage has not decayed below its OFF threshold before attempting to enter the ON state, the channel will continue to be held off, the appropriate bit is set in the STATUS\_MFR\_SPECIFIC register, and the ALERTB pin will be asserted low. When the output voltage has decayed below its OFF threshold, the channel can enter the ON state.

### Automatic Restart Via MFR\_RESTART\_DELAY Command and CONTROLn Pin

An automatic restart sequence can be initiated by driving the CONTROL pin to the off state for  $>10\mu\text{s}$  then releasing it. The automatic restart disables all VOUT\_EN pins that are mapped to a particular CONTROL pin for a time period = MFR\_RESTART\_DELAY and then starts all DC-DC Converters according to their respective TON\_DELAYS. (See Figure 18). VOUT\_ENn pins are mapped to one of the CONTROL pins by the MFR\_CONFIG\_LTC2977 command. This feature allows a host that is about to reset to restart the power in a controlled manner after it has recovered.

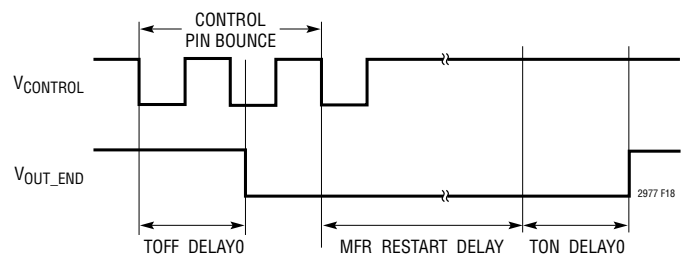


Figure 18. Off Sequence with Automatic Restart

## FAULT MANAGEMENT

### Output Overvoltage and Undervoltage Faults

The high speed voltage supervisor OV and UV fault thresholds are configured using the VOUT\_OV\_FAULT\_LIMIT and VOUT\_UV\_FAULT\_LIMIT commands, respectively. The VOUT\_OV\_FAULT\_RESPONSE and VOUT\_UV\_FAULT\_RESPONSE commands determine the responses to OV/UV faults. Fault responses can range from disabling the DC/DC converter immediately, waiting to see if the fault condition persists for some interval before disabling the DC/DC converter, or allowing the DC/DC converter to continue operating in spite of the fault. If a DC/DC converter is disabled, the LTC2977 can be configured to retry one to six times, retry continuously without limitation, or latch-off. The retry interval is specified using the MFR\_RETRY\_DELAY command. Latched faults are reset by toggling the CONTROL pin, using the OPERATION command, or removing and reapplying the bias voltage to the VIN\_SNS pin. All fault and warning conditions result in



APPLICATIONS INFORMATION

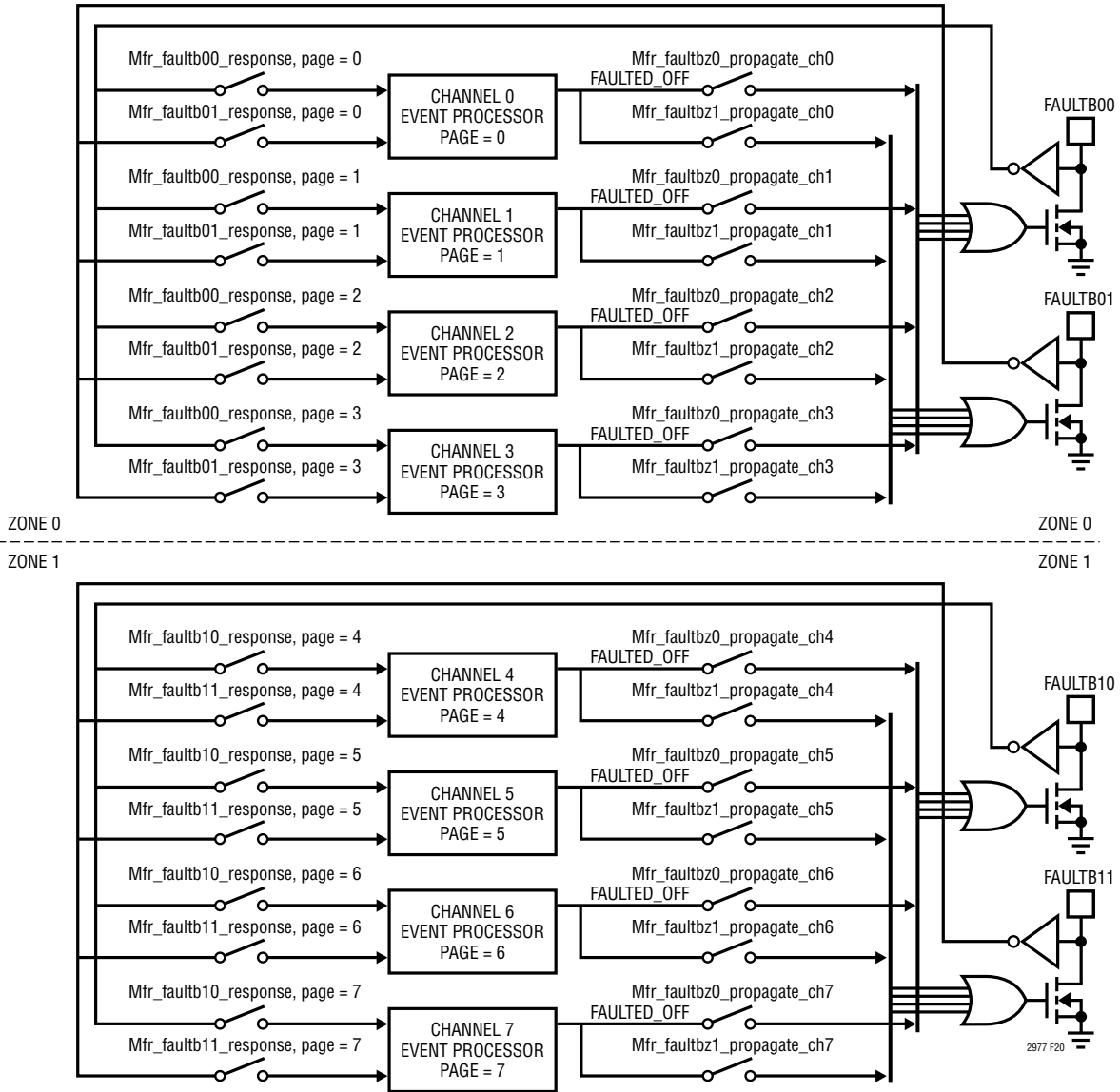


Figure 20. Channel Fault Management Block Diagram

## APPLICATIONS INFORMATION

### Multichannel Fault Management

Multichannel fault management is handled using the bidirectional FAULTBzn pins. The “z” designates the fault zone which is either 0 or 1. There are two fault zones in the LTC2977. Each zone contains 4-channels. Figure 20 illustrates the connections between channels and the FAULTBzn pins.

- The MFR\_FAULTBz0\_PROPAGATE command acts like a programmable switch that allows faulted-off conditions from a particular channel (PAGE) to propagate to either FAULTBzn output in that channel’s zone. The MFR\_FAULTBzn\_RESPONSE command controls similar switches on the inputs to each channel that allow any channel to shut down in response to any combination of the FAULTBzn pins within a zone. Channels responding to a FAULTBzn pin pulling low will attempt a new start sequence when the FAULTBzn pin in question is released by the faulted channel.
- To establish dependencies across fault zones, tie the fault pins together, e.g., FAULTB01 to FAULTB10. Any channel can depend on any other. To disable all channels in response to any channel faulting off, short all the FAULTBzn pins together, and set MFR\_FAULTBzn\_PROPAGATE = 0x01 and MFR\_FAULTBzn\_RESPONSE = 0x0F for all channels.

- A FAULTBzn pin can also be asserted low by an external driver in order to initiate an off-sequence after a 10 $\mu$ s deglitch delay.

### INTERCONNECT BETWEEN MULTIPLE LTC2977’S

Figure 21 shows how to interconnect the pins in a typical multi-LTC2977 array.

- All V<sub>IN\_SNS</sub> lines should be tied together in a star type connection at the point where V<sub>IN</sub> is to be sensed. This will minimize timing errors for the case where the ON\_OFF\_CONFIG is configured to start the LTC2977 based on V<sub>IN</sub> and ignore the CONTROL line and the OPERATION command. In multi-part applications that are sensitive to timing differences, it is recommended that the Vin\_share\_enable bit of the MFR\_CONFIG\_ALL\_LTC2977 register be set high in order to allow SHARE\_CLK to synchronize on/off sequencing in response to the VIN\_ON and VIN\_OFF thresholds.
- Connecting all V<sub>IN\_EN</sub> lines together will allow selected faults on any DC/DC converter’s output in the array to shut off a common input switch.
- ALERTB is typically one line in an array of PMBus converters. The LTC2977 allows a rich combination of faults and warnings to be propagated to the ALERTB pin.

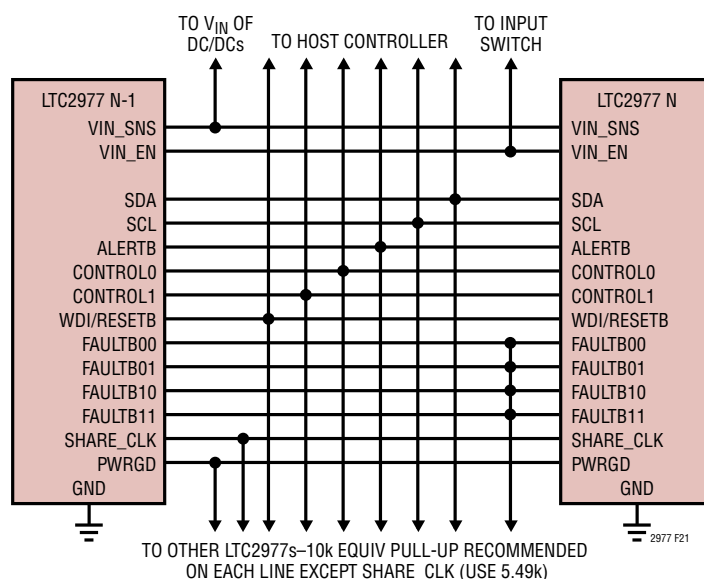


Figure 21. Typical Connections Between Multiple LTC2977s

## APPLICATIONS INFORMATION

- WDI/RESETB can be used to put the LTC2977 in the power-on reset state. Pull WDI/RESETB low for at least  $t_{RESETB}$  to enter this state.
- The FAULTB $zn$  lines can be connected together to create fault dependencies. Figure 21 shows a configuration where a fault on any FAULTB $zn$  will pull all others low. This is useful for arrays where it is desired to abort a start-up sequence in the event any channel does not come up (see Figure 22).
- PWRGD reflects the status of the outputs that are mapped to it by the MFR\_PWRGD\_EN command. Figure 21 shows all the PWRGD pins connected together, but any combination may be used.

## APPLICATION CIRCUITS

### Trimming and Margining DC/DC Converters with External Feedback Resistors

Figure 23 shows a typical application circuit for trimming/margining a power supply with an external feedback network. The  $V_{SENSEPO}$  and  $V_{SENSEMO}$  differential inputs sense the load voltage directly, and a correction voltage is developed between the  $V_{DACPO}$  and  $V_{DACMO}$  pins by the closed-loop servo algorithm.  $V_{DACMO}$  is Kelvin connected to the point-of-load GND in order to minimize the effects of load induced grounding errors. The  $V_{DACPO}$  output is connected to the DC/DC converter's feedback node through resistor R30. For this configuration, set Mfr\_config\_dac\_pol to 0.

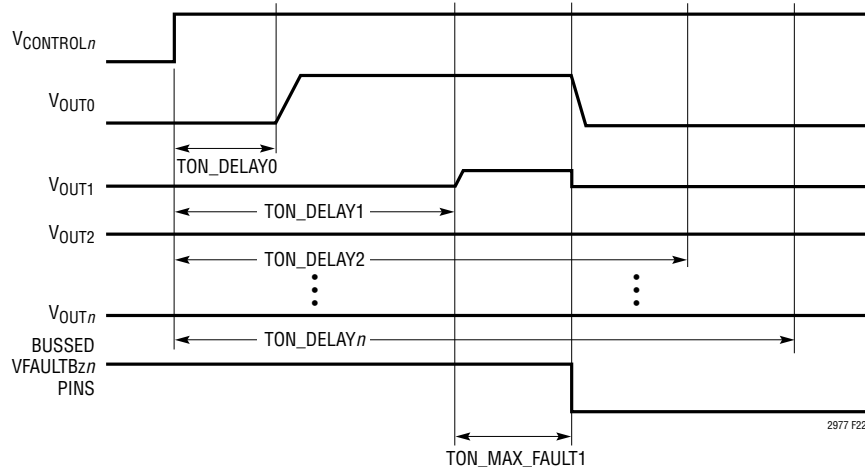
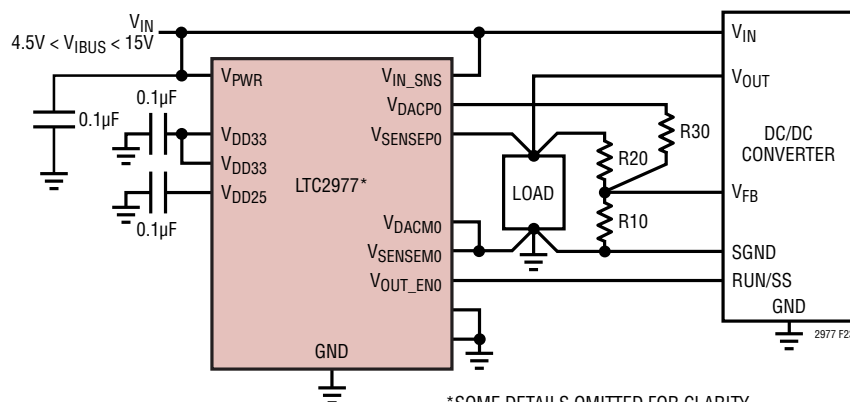


Figure 22. Aborted On Sequence Due to Channel 1 Short



\*SOME DETAILS OMITTED FOR CLARITY  
ONLY ONE OF EIGHT CHANNELS SHOWN

Figure 23. Application Circuit for DC/DC Converters with External Feedback Resistors

## APPLICATIONS INFORMATION

### Four-Step Resistor Selection Procedure for DC/DC Converters with External Feedback Resistors

The following four-step procedure should be used to calculate the resistor values required for the application circuit shown in Figure 23.

1. Assume values for feedback resistor R20 and the nominal DC/DC converter output voltage  $V_{DC(NOM)}$ , and solve for R10.

$V_{DC(NOM)}$  is the output voltage of the DC/DC converter when the LTC2977's  $V_{DACP0}$  pin is in a high impedance state. R10 is a function of R20,  $V_{DC(NOM)}$ , the voltage at the feedback node ( $V_{FB}$ ) when the loop is in regulation, and the feedback node's input current ( $I_{FB}$ ).

$$R10 = \frac{R20 \cdot V_{FB}}{V_{DC(NOM)} - I_{FB} \cdot R20 - V_{FB}} \quad (1)$$

2. Solve for the value of R30 that yields the maximum required DC/DC converter output voltage  $V_{DC(MAX)}$ .

When  $V_{DACP0}$  is at 0V, the output of the DC/DC converter is at its maximum voltage.

$$R30 \leq \frac{R20 \cdot V_{FB}}{V_{DC(MAX)} - V_{DC(NOM)}} \quad (2)$$

3. Solve for the minimum value of  $V_{DACP0}$  that is needed to yield the minimum required DC/DC converter output voltage  $V_{DC(MIN)}$ .

The DAC has two full-scale settings, 1.38V and 2.65V. In order to select the appropriate full-scale setting, calculate the minimum required  $V_{FS\_VDAC}$  output voltage:

$$V_{FS\_VDAC} > (V_{DC(NOM)} - V_{DC(MIN)}) \cdot \frac{R30}{R20} + V_{FB} \quad (3)$$

4. Recalculate the minimum, nominal, and maximum DC/DC converter output voltages and the resulting margining resolution.

$$V_{DC(NOM)} = V_{FB} \cdot \left(1 + \frac{R20}{R10}\right) + I_{FB} \cdot R20 \quad (4)$$

$$V_{DC(MIN)} = V_{DC(NOM)} - \frac{R20}{R30} \cdot (V_{FS\_VDAC} - V_{FB}) \quad (5)$$

$$V_{DC(MAX)} = V_{DC(NOM)} + \frac{R20}{R30} \cdot V_{FB} \quad (6)$$

$$V_{RES} = \frac{\frac{R20}{R30} \cdot V_{FS\_VDAC}}{1023} \text{ V/DAC LSB} \quad (7)$$

## APPLICATIONS INFORMATION

### Trimming and Margining DC/DC Converters with a TRIM Pin

Figure 24 illustrates a typical application circuit for trimming/margining the output voltage of a DC/DC converter with a TRIM Pin. The LTC2977's  $V_{DACP0}$  pin connects to the TRIM pin through resistor R30, and the  $V_{DACM0}$  pin is connected to the converter's point-of-load ground. For this configuration, set the DAC polarity bit  $Mfr\_config\_dac\_pol$  in  $MFR\_CONFIG\_LTC2977$  to 1.

DC/DC converters with a TRIM pin may be margined high or low by connecting an external resistor between the TRIM pin and either the  $V_{SENSEP}$  or  $V_{SENSEM}$  pin. The relationships between these resistors and the  $\Delta\%$  change in the output voltage of the DC/DC converter are typically expressed as:

$$R_{TRIM\_DOWN} = \frac{R_{TRIM} \cdot 50}{\Delta_{DOWN}\%} - R_{TRIM} \quad (8)$$

$$R_{TRIM\_UP} =$$

$$R_{TRIM} \cdot \left[ \frac{V_{DC} \cdot (100 + \Delta_{UP}\%)}{2 \cdot V_{REF} \cdot \Delta_{UP}\%} - \left( \frac{50}{\Delta_{UP}\%} \right) - 1 \right] \quad (9)$$

where  $R_{TRIM}$  is the resistance looking into the TRIM pin,  $V_{REF}$  is the TRIM pin's open-circuit output voltage and  $V_{DC}$  is the DC/DC converter's nominal output voltage.  $\Delta_{UP}\%$  and  $\Delta_{DOWN}\%$  denote the percentage change in the converter's output voltage when margining up or down, respectively.

### Two-Step Resistor and DAC Full-Scale Voltage Selection Procedure for DC/DC Converters with a TRIM Pin

The following two-step procedure should be used to calculate the resistor value for R30 and the required full-scale DAC voltage (refer to Figure 24).

1. Solve for R30:

$$R30 \leq R_{TRIM} \cdot \left( \frac{50 - \Delta_{DOWN}\%}{\Delta_{DOWN}\%} \right) \quad (10)$$

2. Calculate the maximum required output voltage for  $V_{DACP0}$ :

$$V_{DACP0} \geq \left( 1 + \frac{\Delta_{UP}\%}{\Delta_{DOWN}\%} \right) \cdot V_{REF} \quad (11)$$

Note: Not all DC/DC's converters follow these trim equations especially newer bricks. Consult LTC Field Application Engineering.

### Measuring Current

Odd numbered ADC channels may be used to measure supply current. Set the ADC to high resolution mode to configure for current measuring and improve sensitivity. Note that no OV or UV faults or warnings are reported in this mode, but telemetry is available from the  $READ\_VOUT$  command using the 11-bit signed mantissa plus 5-bit signed exponent L11 data format. Set the  $MFR\_CONFIG\_LTC2977$  bit  $b[9] = 1$  in order to enable high res mode.

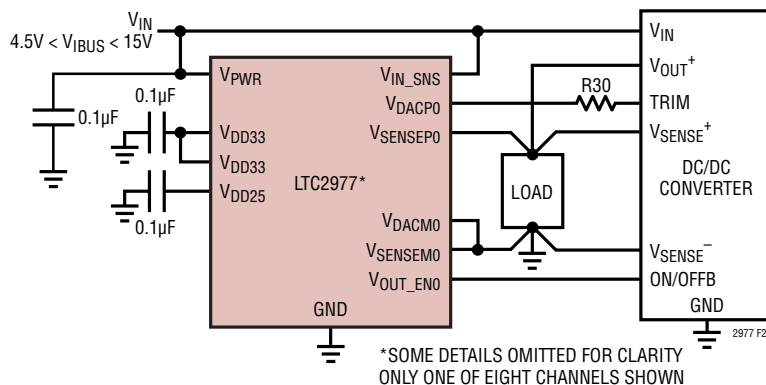


Figure 24. Application Circuit for DC/DC Converters with Trim Pin

## APPLICATIONS INFORMATION

The  $V_{OUT\_EN}$  pin will assert low in this mode and cannot be used to control a DC/DC converter. The  $V_{DACP}$  output pin is also unavailable.

### Measuring Current with a Sense Resistor

A circuit for measuring current with a sense resistor is shown in Figure 25. The balanced filter rejects both common mode and differential mode noise from the output of the DC/DC converter. The filter is placed directly across the sense resistor in series with the DC/DC converter's inductor. Note that the current sense inputs must be limited to less than 6V with respect to ground. Select  $R_{CM}$  and  $C_{CM}$  such that the filter's corner frequency is  $< 1/10$  the DC/DC converter's switching frequency. This will result in a current sense waveform that offers a good compromise between the voltage ripple and the delay through the filter. A value  $1k\Omega$  for  $R_{CM}$  is suggested in order to minimize gain errors due to the current sense inputs' internal resistance.

### Measuring Current with Inductor DCR

Figure 26 shows the circuit for applications that require DCR current sense. A second order RC filter is required in these applications in order to minimize the ripple

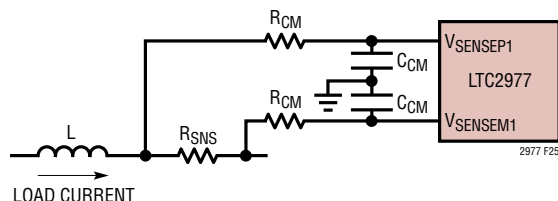


Figure 25. Sense Resistor Current Sensing Circuits

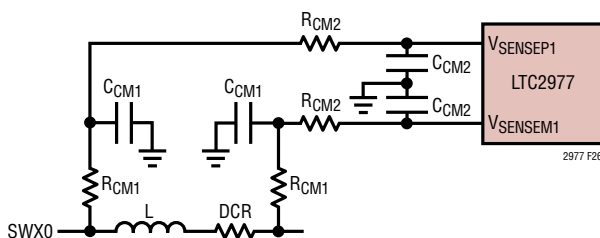


Figure 26. Inductor DCR Current Sensing Circuits

voltage seen at the current sense inputs. A value of  $1k\Omega$  is suggested for  $R_{CM1}$  and  $R_{CM2}$  in order to minimize gain errors due to the current sense inputs' internal resistance.  $C_{CM1}$  should be selected to provide cancellation of the zero created by the DCR and inductance, i.e.  $C_{CM1} = L / (DCR \cdot R_{CM1})$ .  $C_{CM2}$  should be selected to provide a second stage corner frequency at  $< 1/10$  of the DC/DC converter's switching frequency. In addition,  $C_{CM2}$  needs to be much smaller than  $C_{CM1}$  in order to prevent significant loading of the filter's first stage.

### Single Phase Design Example

As a design example for a DCR current sense application, assume  $L = 2.2\mu H$ ,  $DCR = 10m\Omega$ , and  $F_{SW} = 500kHz$ .

Let  $R_{CM1} = 1k\Omega$  and solve for  $C_{CM1}$ :

$$C_{CM1} \geq \frac{2.2\mu H}{10m\Omega \cdot 1k\Omega} = 220nF$$

Let  $R_{CM2} = 1k\Omega$ . In order to get a second pole at  $F_{SW}/10 = 50kHz$ :

$$C_{CM2} = \frac{1}{2\pi \cdot 50kHz \cdot 1k\Omega} = 3.18nF$$

Let  $C_{CM2} = 3.3nF$ . Note that since  $C_{CM2}$  is much less than  $C_{CM1}$  the loading effects of the second stage filter on the matched first stage are not significant. Consequently, the delay time constant through the filter for the current sense waveform will be approximately  $3\mu s$ .

### Measuring Multiphase Currents

For current sense applications with more than one phase, RC averaging may be employed. Figure 27 shows an example of this approach for a 3-phase system with DCR current sensing. The current sense waveforms are averaged together prior to being applied to the second stage of the filter consisting of  $R_{CM2}$  and  $C_{CM2}$ . Because the  $R_{CM1}$  resistors for the three phases are in parallel, the value of  $R_{CM1}$  must be multiplied by the number of phases. Also note that since the DCRs are effectively in parallel, the value for  $I_{OUT\_CAL\_GAIN}$  will be equal to the inductor's

## APPLICATIONS INFORMATION

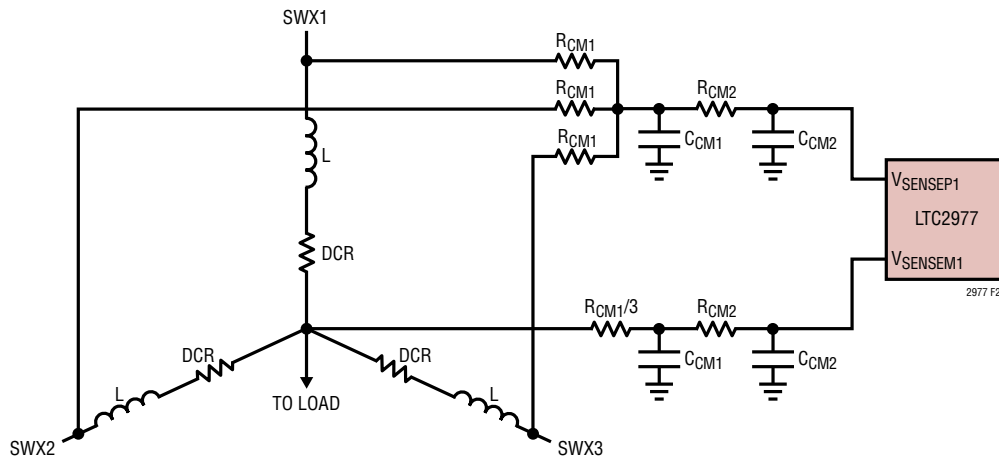


Figure 27. Multiphase DCR Current Sensing Circuits

DCR divided by the number of phases. Care should be taken in the layout of the multiphase inductors to keep the PCB trace resistance from the DC side of each inductor to the summing node balanced in order to provide the most accurate results.

### Multiphase Design Example

Using the same values for inductance and DCR from the previous design example, the value for  $R_{CM1}$  will be  $3k\Omega$  for a three phase DC/DC converter if  $C_{CM1}$  is left at  $220nF$ . Similarly, the value for  $IOUT\_CAL\_GAIN$  will be  $DCR/3 = 3.33m\Omega$ .

### Anti-aliasing Filter Considerations

Noisy environments require an anti-aliasing filter on the input to the LTC2977's ADC. The R-C circuit shown in Figure 28 is adequate for most situations. Keep  $R40 = R50 \leq 200\Omega$  to minimize ADC gain errors, and select a value for capacitors  $C10$  and  $C20$  that does not add too much additional response time to the OV/UV supervisor, e.g.  $\tau \cong 10\mu s$  ( $R = 100\Omega$ ,  $C = 0.10\mu F$ ).

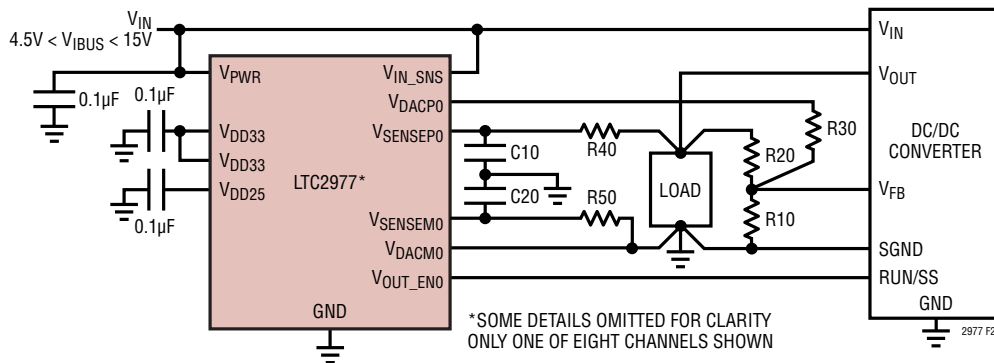


Figure 28. Anti-Aliasing Filter on  $V_{SENSE}$  Lines

## APPLICATIONS INFORMATION

### Sensing Negative Voltages

Figure 29 shows the LTC2977 sensing a negative power supply ( $V_{EE}$ ). The R1/R2 resistor divider translates the negative supply voltage to the LTC2977's VSENSEM1 input while the VSENSEP1 input is tied to the REFP pin which has a typical output voltage of 1.23V. The voltage divider should be configured in order to present about 0.5V to the voltage sense inputs when the negative supply reaches its POWER\_GOOD\_ON threshold so that the current flowing out of the VSENSEMn pin is minimized to  $\sim 1\mu\text{A}$ . The relationship between the POWER\_GOOD\_ON register value and the corresponding negative supply value can be expressed as:

$$V_{EE} = V_{REFP} - (\text{READ\_VOUT}) \cdot \left( \frac{R2}{R1} + 1 \right) - 1\mu\text{A} \cdot R2$$

where READ\_VOUT returns  $V_{SENSEP} - V_{SENSEM}$ .

### Connecting the DC1613 USB to I<sup>2</sup>C/SMBus/PMBus Controller to the LTC2977 in System

The DC1613 USB to I<sup>2</sup>C/SMBus/PMBus Controller can be interfaced to LTC2977s on the user's board for programming, telemetry and system debug. The controller, when used in conjunction with LTpowerPlay software, provides

a powerful way to debug an entire power system. Failures are quickly diagnosed using telemetry, fault status registers and the fault log. The final configuration can be quickly developed and stored to the LTC2977's EEPROM.

Figure 30 and 31 illustrate application schematics for powering, programming and communicating with one or more LTC2977's via the DC1613 I<sup>2</sup>C/SMBus/PMBus controller regardless of whether or not system power is present.

Figure 30 shows the recommended schematic to use when the LTC2977 is powered by the system intermediate bus through its  $V_{PWR}$  pin.

Figure 31 shows the recommended schematic to use when the LTC2977 is powered by the system 3.3V through its  $V_{DD33}$  and  $V_{PWR}$  pins. The LTC4412 ideal OR'ing circuit allows either the controller or system to power the LTC2977.

Because of the controller's limited current sourcing capability, only the LTC2977s, their associated pull up resistors and the I<sup>2</sup>C/SMBus pull-up resistors should be powered from the ORed 3.3V supply. In addition, any device sharing I<sup>2</sup>C/SMBus bus connections with the LTC2977 should not have body diodes between the SDA/SCL pins and its  $V_{DD}$  node because this will interfere with bus communication in the absence of system power.

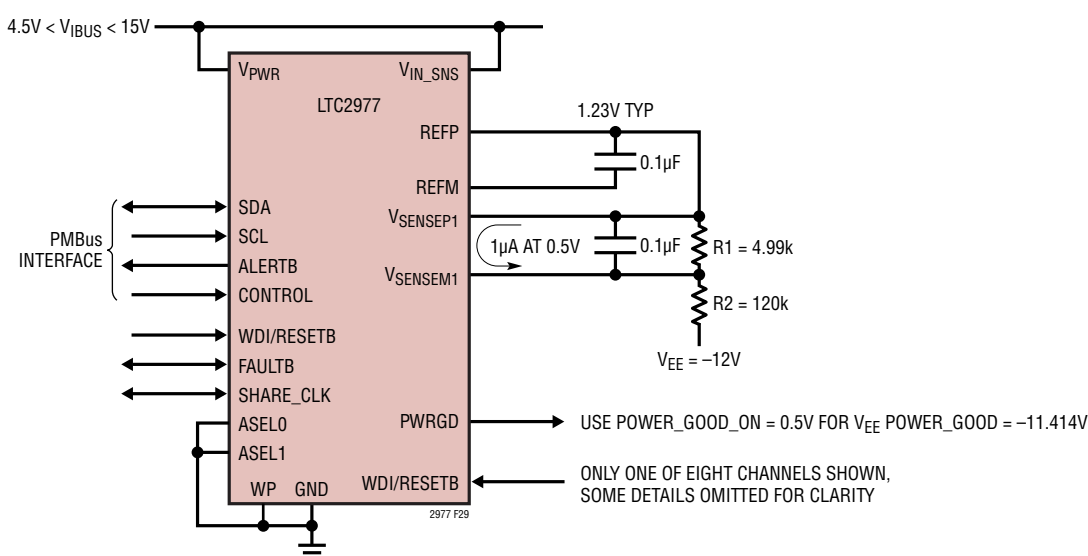


Figure 29. Sensing Negative Voltages

APPLICATIONS INFORMATION

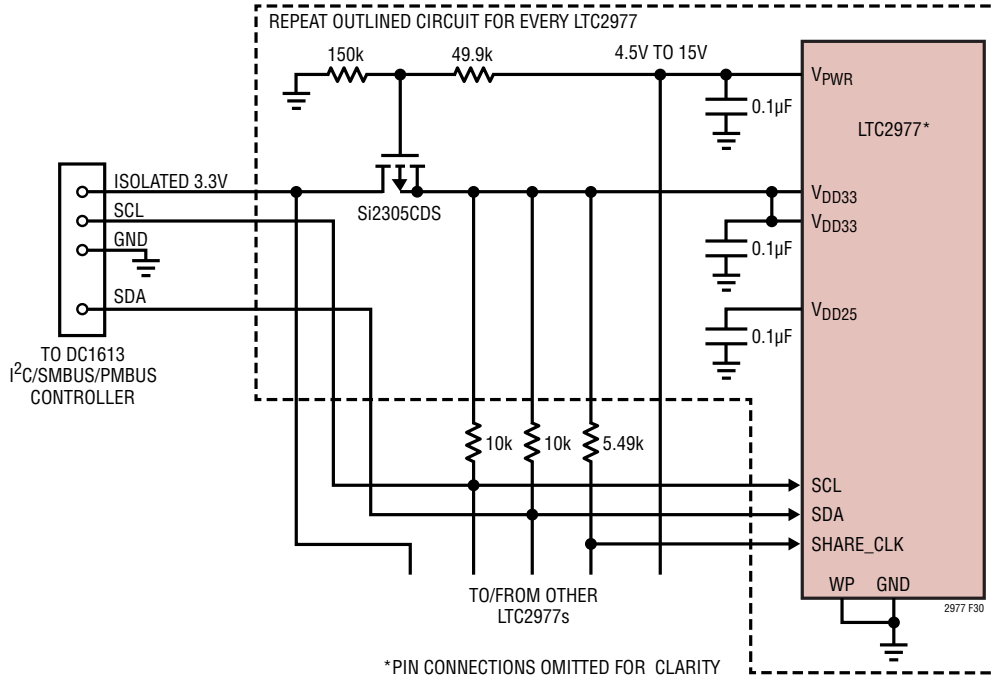
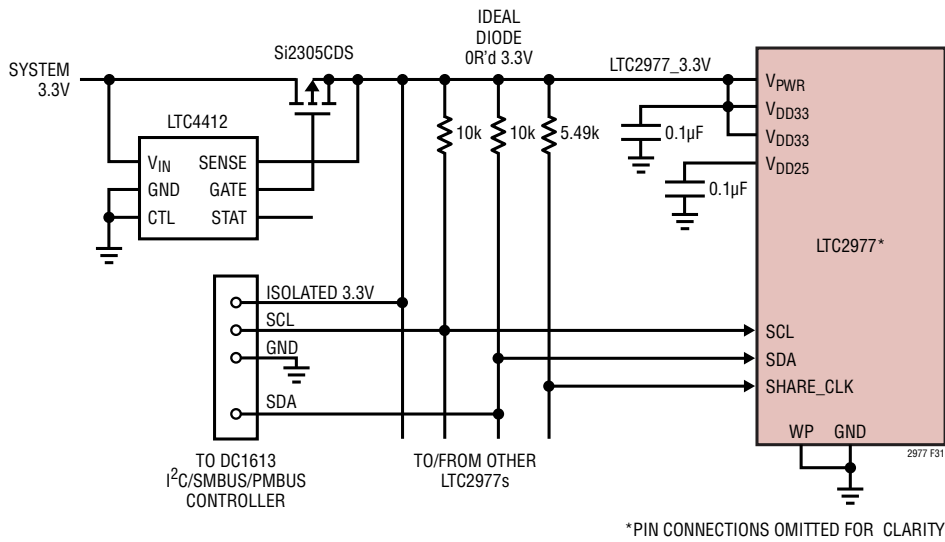


Figure 30. DC1613 Controller Connections When  $V_{PWR}$  Is Used



NOTE: DC1613 CONTROLLER  $I^2C$  CONNECTIONS ARE OPTO-ISOLATED  
 ISOLATED 3.3V FROM CONTROLLER CAN BE BACK DRIVEN AND WILL ONLY DRAW  $< 10\mu A$   
 ISOLATED 3.3V CURRENT LIMIT = 100mA

Figure 31. DC1613 Controller Connections When LTC2977 Powered Directly from 3.3V

## APPLICATIONS INFORMATION

The DC1613 controller's I<sup>2</sup>C/SMBus connections are opto-isolated from the PC's USB port. The 3.3V supply from the controller and the LTC2977's V<sub>DD33</sub> pin can be paralleled because the LTC LDOs that generate these voltages can be backdriven and draw <10μA. The controller's 3.3V current limit is 100mA.

### DESIGN CHECKLIST

#### I<sup>2</sup>C

- The LTC2977 must be configured for a unique address.
- The address select pins (ASEL<sub>n</sub>) are tri-level; check Table 1.
- Check addresses for collision with other devices on the bus and any global addresses.

#### Output Enables

- Use appropriate pull-up resistors on all V<sub>OUT\_EN<sub>n</sub></sub> pins.
- Verify that the absolute maximum ratings of the V<sub>OUT\_EN<sub>n</sub></sub> pins are not exceeded.

#### V<sub>IN</sub> Sense

- No external resistive divider is required to sense V<sub>IN</sub>; V<sub>IN\_SNS</sub> already has an internal calibrated divider.

#### Logic Signals

- Verify the absolute maximum ratings of the digital pins (SCL, SDA, ALERTB, FAULTB<sub>zn</sub>, CONTROL<sub>n</sub>, SHARE\_CLK, WDI, ASEL<sub>n</sub>, PWRGD) are not exceeded.
- Short all SHARE\_CLK pins in the system together and pull up to 3.3V with a 5.49k resistor.
- Do not leave CONTROL<sub>n</sub> pins floating. Pull up to 3.3V with a 10k resistor.
- Tie WDI/RESETB to V<sub>DD33</sub> with a 10k resistor. Do not connect a capacitor to the WDI/RESETB pin.
- Tie WP to either V<sub>DD33</sub> or GND. Do not leave floating.

#### Unused Inputs

- Connect all unused V<sub>SENSE<sub>Pn</sub></sub>, V<sub>SENSE<sub>Mn</sub></sub> and DACM<sub>n</sub> pins to GND. Do not float unused inputs. Refer to Unused ADC Sense Inputs in the Applications Information section.

#### DAC Outputs

- Select appropriate resistor for desired margin range. Refer to the resistor selection tool in LTpowerPlay for assistance.

For a more complete list of design considerations and a schematic checklist, see the Design Checklist on the LTC2977 product page:

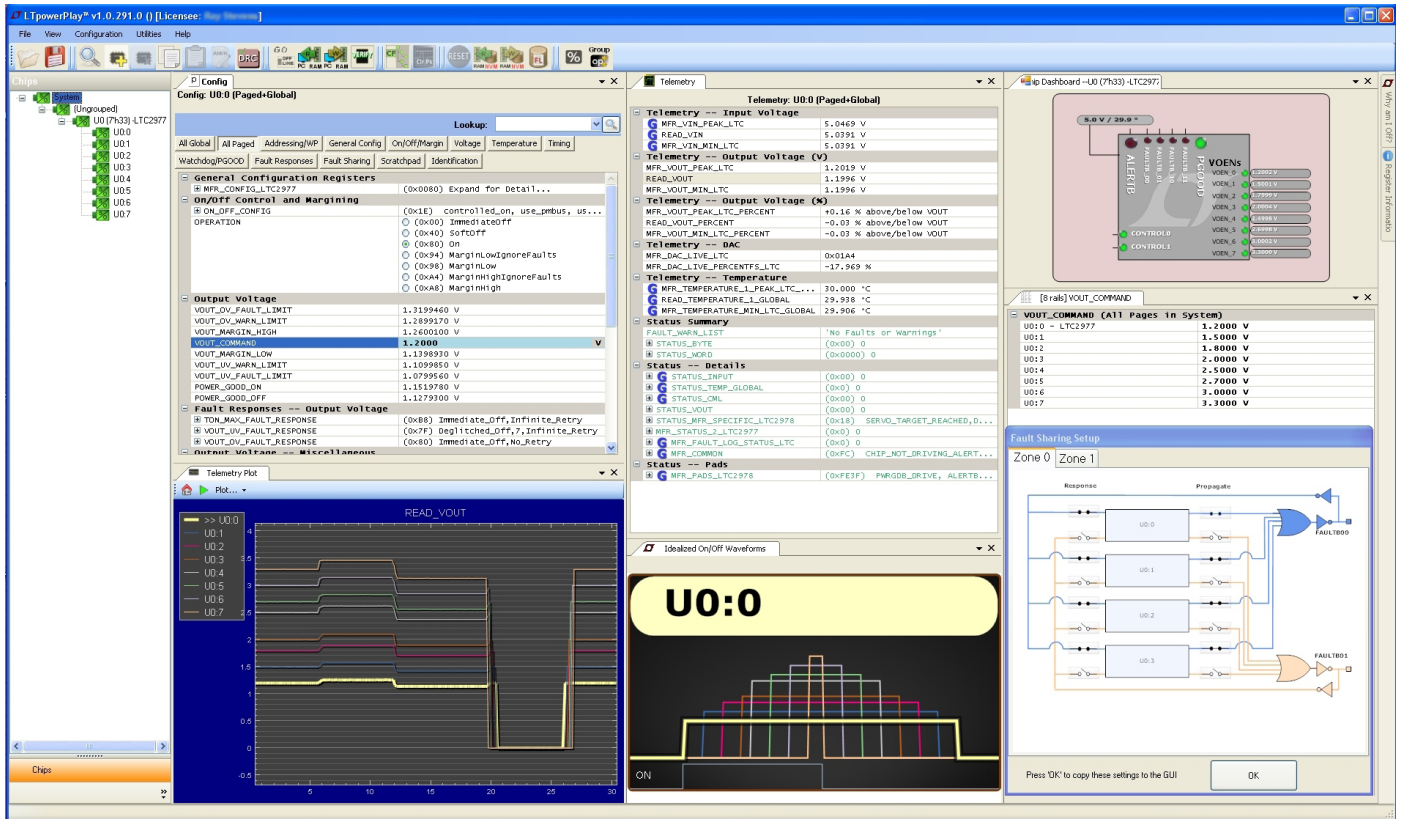
[LTC2977](#)

### LTpowerPlay: AN INTERACTIVE GUI FOR POWER SYSTEM MANAGERS

LTpowerPlay is a powerful Windows based development environment that supports Analog Devices Power System Manager ICs with EEPROM, including the LTC2977 8-channel PMBus Power System Manager. The software supports a variety of different tasks. You can use LTpowerPlay to evaluate Analog Devices ICs by connecting to a demo board system. LTpowerPlay can also be used in an offline mode (with no hardware present) in order to build a multi-chip configuration file that can be saved and reloaded at a later time. LTpowerPlay provides unprecedented diagnostic and debug features. It becomes a valuable diagnostic tool during board bring-up to program or tweak the power management scheme in a system or to diagnose power issues when bringing up rails. LTpowerPlay utilizes Analog Devices' DC1613 USB-to-I<sup>2</sup>C/SMBus/PMBus Controller to communicate with one of many potential targets, including the DC2028 demo board set, the DC1508 socketed programming board, or a customer target system. The software also provides an automatic update feature to keep the software current with the latest set of device drivers and documentation. A great deal of context sensitive help is available within LTpowerPlay along with several tutorial demos. Complete information is available at:

[ltpowerplay](#)

## APPLICATIONS INFORMATION



### PCB ASSEMBLY AND LAYOUT SUGGESTIONS

#### Bypass Capacitor Placement

The LTC2977 requires 0.1µF bypass capacitors between the V<sub>DD33</sub> pins and GND, the V<sub>DD25</sub> pin and GND, and the REFP pin and REFM pin. If the chip is being powered from the V<sub>PWR</sub> input, then that pin should also be bypassed to GND by a 0.1µF capacitor. In order to be effective, these capacitors should be made of high quality ceramic dielectric such as X5R or X7R and be placed as close to the chip as possible.

#### Exposed Pad Stencil Design

The LTC2977's package is thermally and electrically efficient. This is enabled by the exposed die attach pad on the under side of the package which must be soldered down to the PCB or mother board substrate. It is a good practice to minimize the presence of voids within the exposed pad inter-connection. Total elimination of voids is difficult, but the design of the exposed pad stencil is key. Figure 32 shows a suggested screen print pattern. The proposed stencil design enables out-gassing of the solder paste during reflow as well as regulating the finished solder thickness. See IPC7525A.

## APPLICATIONS INFORMATION

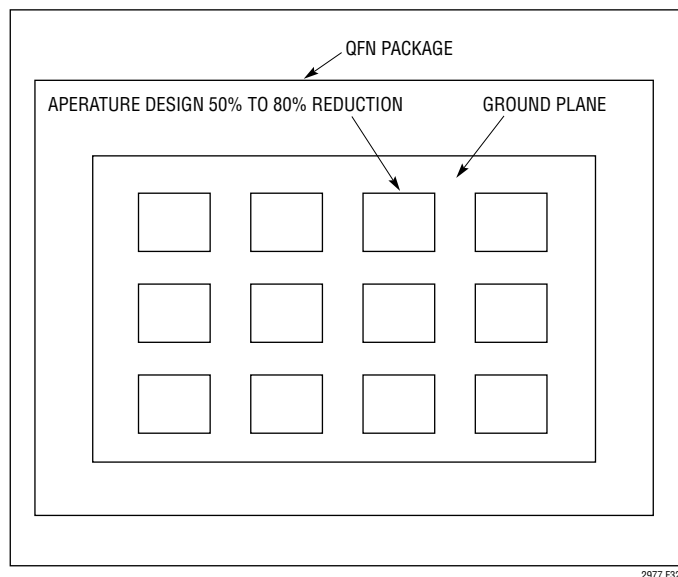


Figure 32. Suggested Screen Pattern for Die Attach Pad

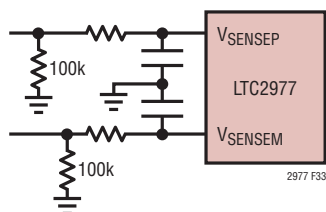


Figure 33. Connecting Unused Inputs to GND

### PC Board Layout

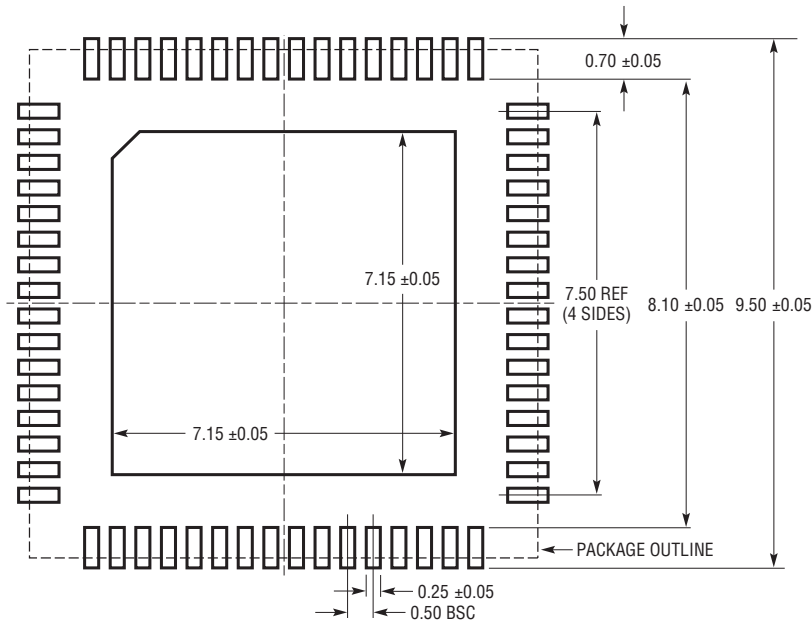
Mechanical stress on a PC board and soldering-induced stress can cause the LTC2977's reference voltage and voltage drift to shift. A simple way to reduce these stress-related shifts is to mount the IC near the short edge of the PC board, or in a corner. The board edge acts as a stress boundary, or a region where the flexure of the board is minimal.

### Unused ADC Sense Inputs

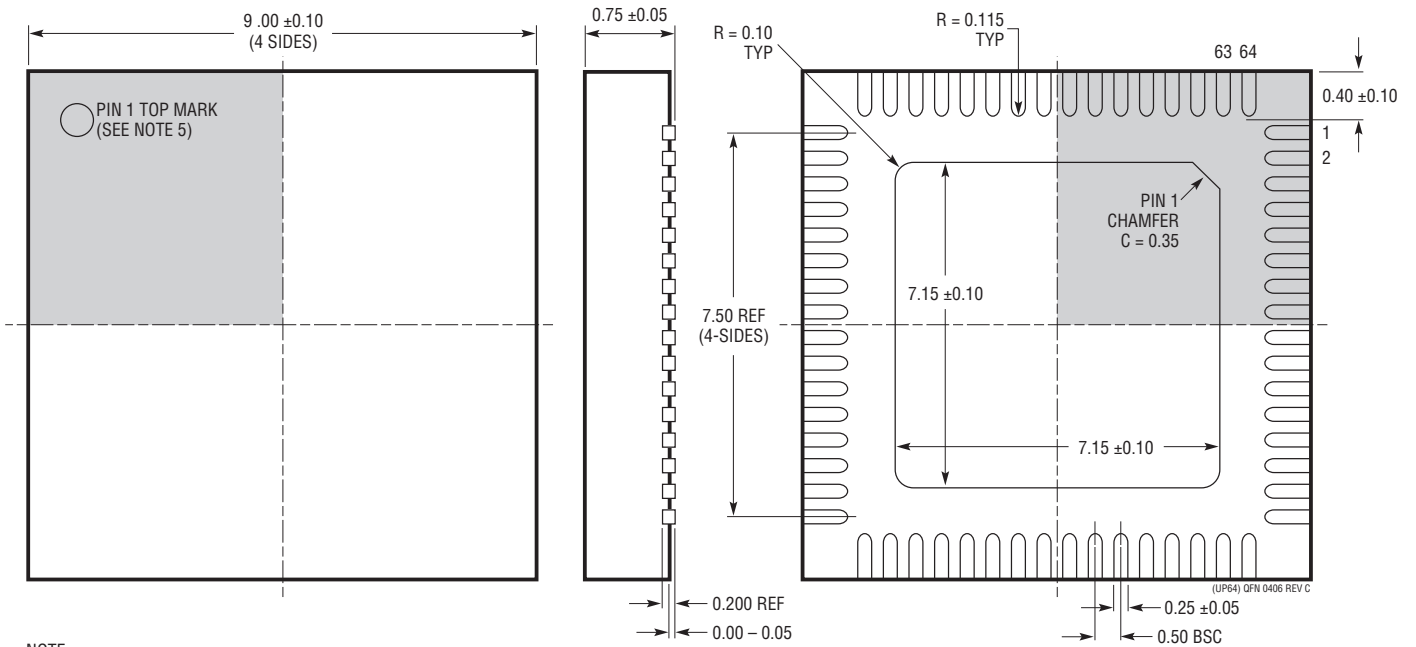
Connect all unused ADC sense inputs ( $V_{SENSEp_n}$  or  $V_{SENSEm_n}$ ) to GND. In a system where the inputs are connected to removable cards and may be left floating in certain situations, connect the inputs to GND using 100k resistors. Place the 100k resistors before any filter components, as shown in Figure 33, to prevent loading of the filter.

**PACKAGE DESCRIPTION**

**UP Package**  
**64-Lead Plastic QFN (9mm × 9mm)**  
 (Reference LTC DWG # 05-08-1705 Rev C)



RECOMMENDED SOLDER PAD PITCH AND DIMENSIONS  
 APPLY SOLDER MASK TO AREAS THAT ARE NOT SOLDERED



BOTTOM VIEW—EXPOSED PAD

- NOTE:
1. DRAWING CONFORMS TO JEDEC PACKAGE OUTLINE MO-220 VARIATION WJNR-5
  2. ALL DIMENSIONS ARE IN MILLIMETERS
  3. DIMENSIONS OF EXPOSED PAD ON BOTTOM OF PACKAGE DO NOT INCLUDE MOLD FLASH. MOLD FLASH, IF PRESENT, SHALL NOT EXCEED 0.20mm ON ANY SIDE, IF PRESENT
  4. EXPOSED PAD SHALL BE SOLDER PLATED
  5. SHADED AREA IS ONLY A REFERENCE FOR PIN 1 LOCATION ON THE TOP AND BOTTOM OF PACKAGE
  6. DRAWING NOT TO SCALE

## REVISION HISTORY

REV	DATE	DESCRIPTION	PAGE NUMBER
A	09/13	Improved the voltage range for ADC Total Unadjusted Error (TUE) specification, Voltage Sense Mode, from >1.8V to >1V	5
		Added ADC TUE specification for Current Sense Mode	5
		Consolidated previous ADC specifications – INL, DNL, Voltage Sense Offset Error, Gain Error – into TUE	5
		Updated $V_{OS\_CMP}$ Offset Voltage specification	7
		$V_{OUT\_ENn}$ Output High Voltage specification: Changed minimum from 11.6V to 10V	7
		Added Typical Performance Characteristic: Closed-Loop Servo Accuracy	11
B	08/16	Updated Typical Application and added EEPROM ECC information	1, 16, 17, 58
		Updated DAC Output Update Rate ( $t_{S\_VDACP}$ )	6
		Added Note 3	9
		Updated graph: Closed Loop Servo Error	11
		Added graph: $V_{OUT\_EN[7:0]}$ Output Voltage vs $V_{DD33}$	12
		Updated $V_{DD33}$ , $V_{DD25}$ and SHARE_CLK pin functions	13
		Updated value of k and resulting example in EEPROM section	17
		Updated: Figures 1a, 7 to 12; Table 1	19, 20, 21
		Added MFR_INFO command	25, 58
		Changed MFR_SPECIAL_ID default value	26, 58
		Added MFR_COMMAND_PLUS to list of excepted commands under Level 2 write protection	28
		Updated: WRITE_PROTECT Pin section, MFR_STATUS_PLUSn Data Contents	29, 31
		Updated: STATUS_WORD b[0] operation, STATUS_VOUT b[3] symbol and operation	41, 42
		Updated description: MFR_VOUT_PEAK, MFR_VIN_PEAK, MFR_TEMPERATURE_PEAK, MFR_VOUT_MIN, MFR_VIN_MIN, MFR_TEMPERATURE_MIN	56, 60, 61
Updated: Figure 19, P-channel MOSFETs in Figures 30 and 31	79, 86		
Updated Design Checklist	87		
C	04/17	Added $V_{VOUT\_VALID}$ specifications	7
D	03/20	Updated MFR_DAC default value	26
E	10/20	Added AEC-Q100 Qualified for Automotive Applications and orderable part numbers	1, 4
F	07/22	$V_{OS\_ADC}$ Offset Error maximum spec limit changed from $\pm 35\mu V$ to $\pm 100\mu V$	5
		$I_{VOUT\_ENn}$ Output Sinking Current at condition Weak Pull-Down Enabled: minimum spec changed from $33\mu A$ to $28\mu A$ and typical spec changed from $50\mu A$ to $43\mu A$ .	7
		$I_{VOUT\_ENn}$ Output Sinking Current at condition Strong Pulldown Enabled, $V_{OUT\_ENn} = 0.1V$ : spec updated to typical value only at room temp	
		Updated VDD3 and VDD25 Pin Descriptions	13
		Updated section on Processing Commands and Associated Command Tables	22
		Updated offset value in the example scenario in MFR_I2C_BASE_ADDRESS section	30
		Updated text in Response When Part Is Busy section	65
Updated Table Numbers	68, 69		
G	12/24	Changed $t_{INIT}$ from 30ms to 42ms in the Electrical Characteristics table	5

TYPICAL APPLICATION

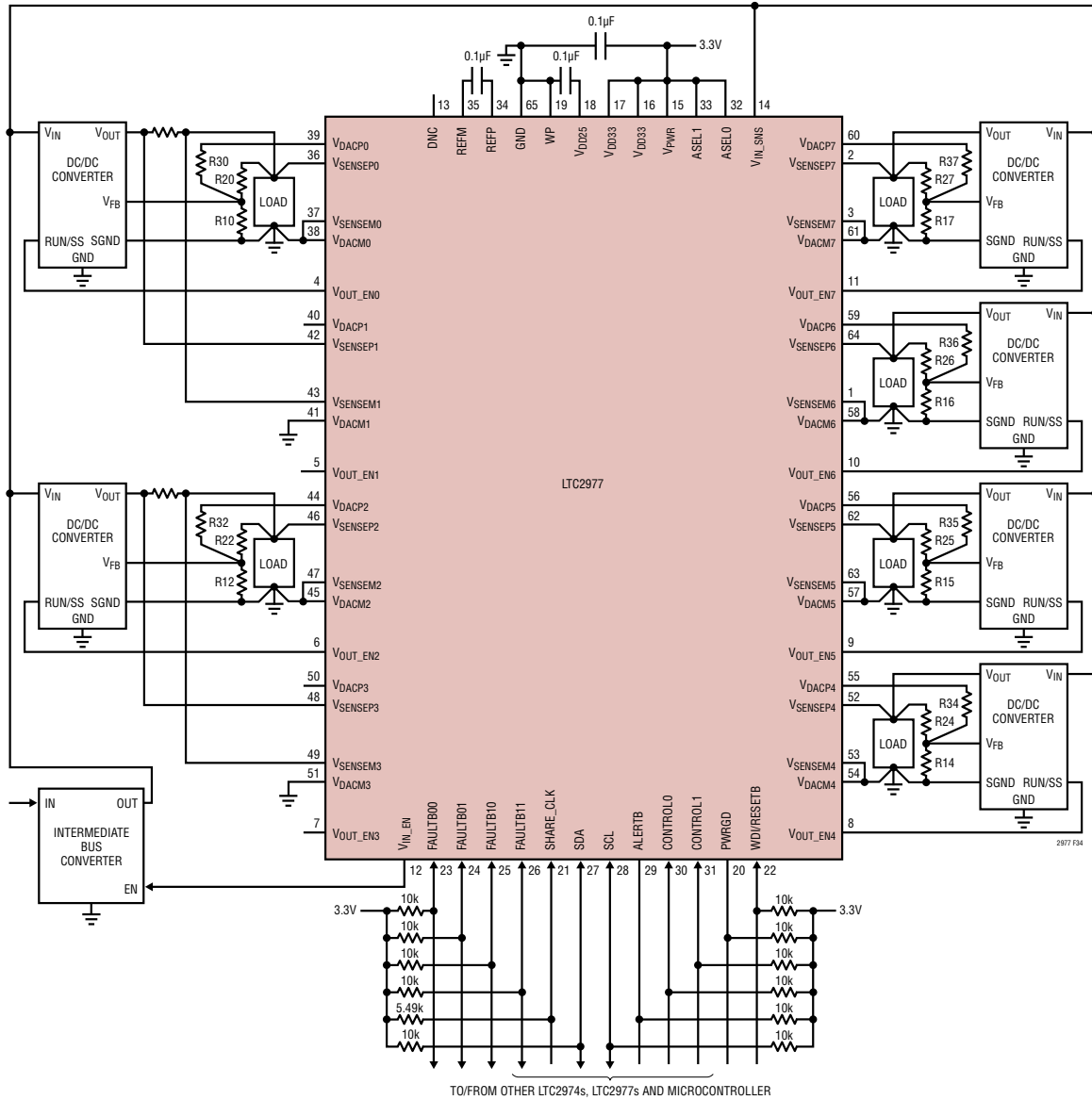


Figure 34. LTC2977 Application Circuit with 3.3V Chip Power

RELATED PARTS

PART NUMBER	DESCRIPTION	COMMENTS
<a href="#">LTC2970</a>	Dual I <sup>2</sup> C Power Supply Monitor and Margining Controller	5V to 15V, 0.5% TUE 14-Bit ADC, 8-Bit DAC, Temperature Sensor
<a href="#">LTC2974</a>	4-Channel PMBus Power System Manager	0.25% TUE 16-Bit ADC, Voltage/Current/Temperature Monitoring and Supervision
<a href="#">LTC2975</a>	4-Channel PMBus Power System Manager	0.25% TUE 16-Bit ADC, Voltage/Current/Temperature Monitoring and Supervision, Input Current and Power, Input Energy Accumulator
<a href="#">LTC2980</a>	16-Channel PMBus Power System Manager	Dual LTC2977
<a href="#">LTM2987</a>	16-Channel μModule PMBus Power System Manager	Dual LTC2977 with Integrated Passive Components
<a href="#">LTC3880</a>	Dual Output PolyPhase Step-Down DC/DC Controller	0.5% TUE 16-Bit ADC, Voltage/Current/Temperature Monitoring and Supervision
<a href="#">LTC3883</a>	Single Output PolyPhase Step-Down DC/DC Controller	0.5% TUE 16-Bit ADC, Voltage/Current/Temperature Monitoring and Supervision