

REVISIONS					
P	LTR	DESCRIPTION	DATE	DWN	APVD
A1		NEW DRAWING	28AUG2023	NK	JDB
J1		DRAWING RE-CREATED IN CREO	26DEC2023	NK	JDB

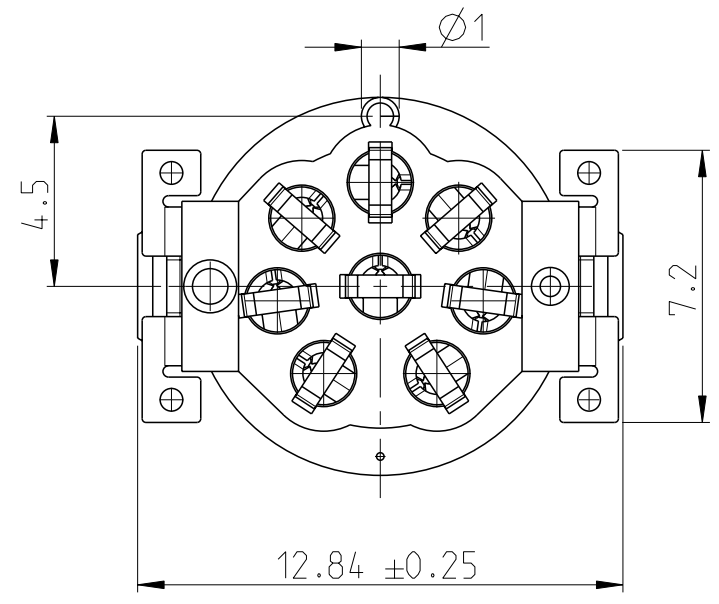

INSPECTION LEVEL 1: CONTROL CHART REQUIRED
 (1) PROOF OF PROCESS CAPABILITY OR 100% TEST IF PROCESS CAPABILITY IS NOT ACHIEVED

INSPECTION LEVEL 2 AND 3: CONTROL CHART REQUIRED
 (2) PROOF OF MEAN VALUE, STANDARD DEVIATION AND MACHINE CAPABILITY

(3) PROOF OF VALUES OR PROOF OF ATTRIBUTIVE TEST

INFORMATION ON THE SCOPE OF TESTING AND DETECTION BY ERNI VA 7.3.2.3

TAPE ON REEL PACKAGING ACCORDING TO DIN IEC 60286-3
 PACKAGING UNIT: 100 PCS

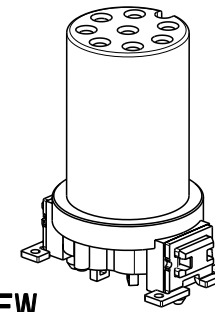

3D VIEW
SCALE 2:1

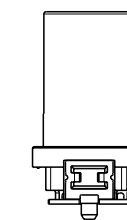
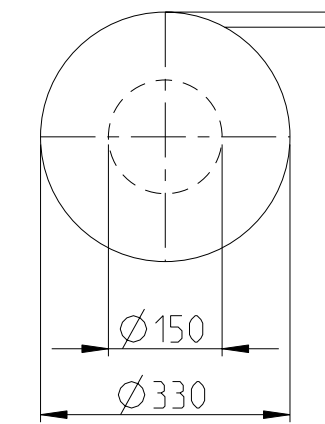

CONSIDER MOUNTING POSITION; PEG RIGHT

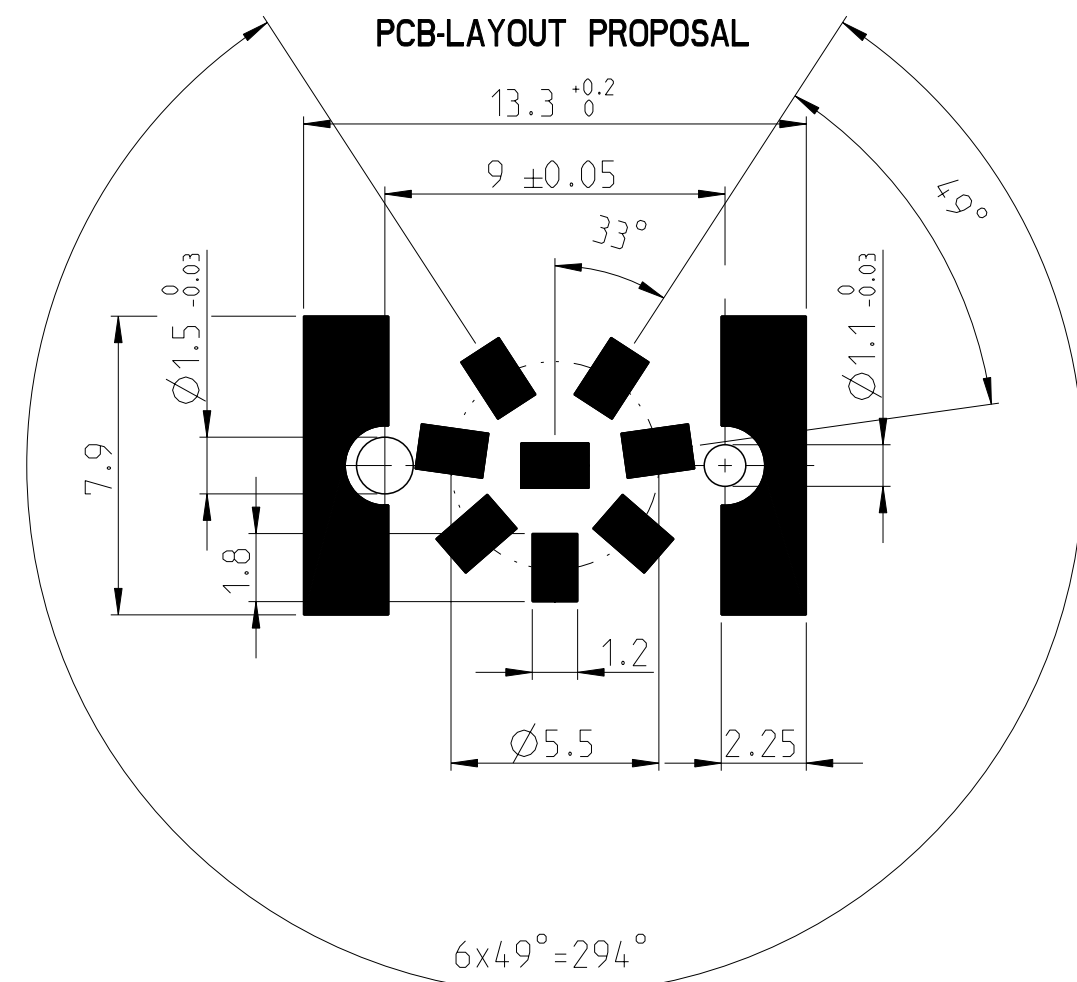
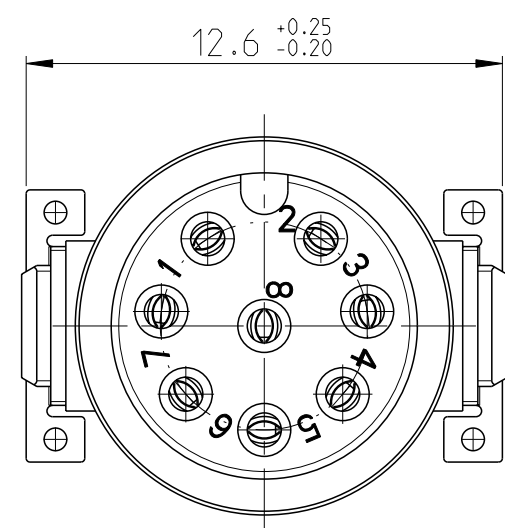
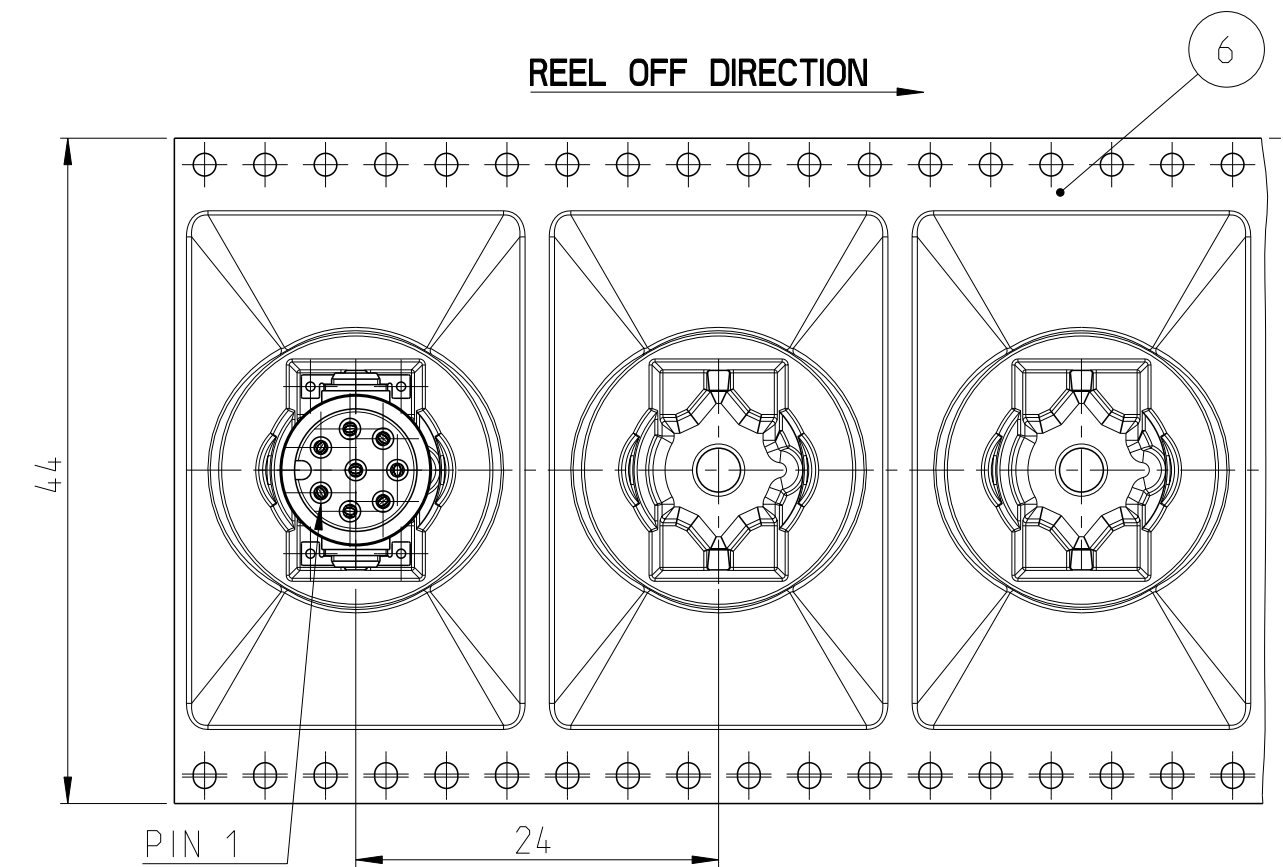
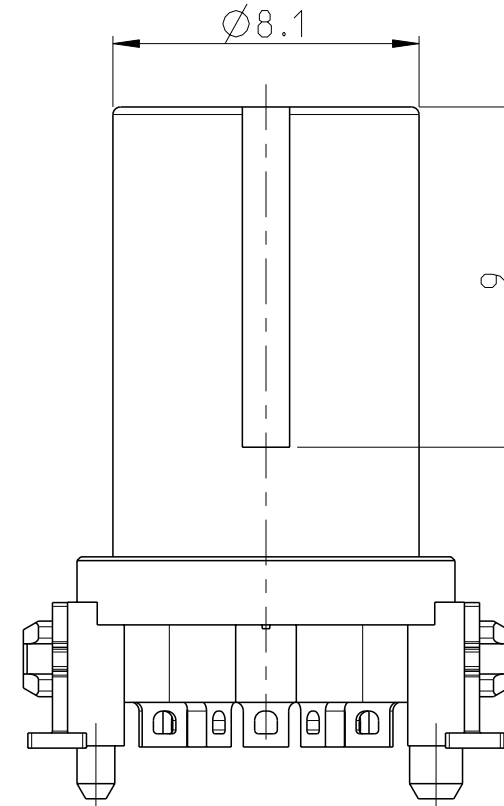
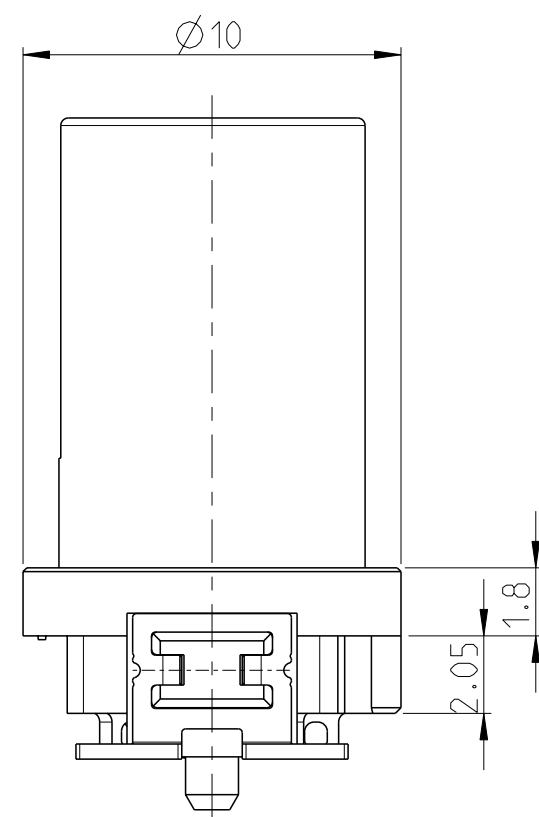
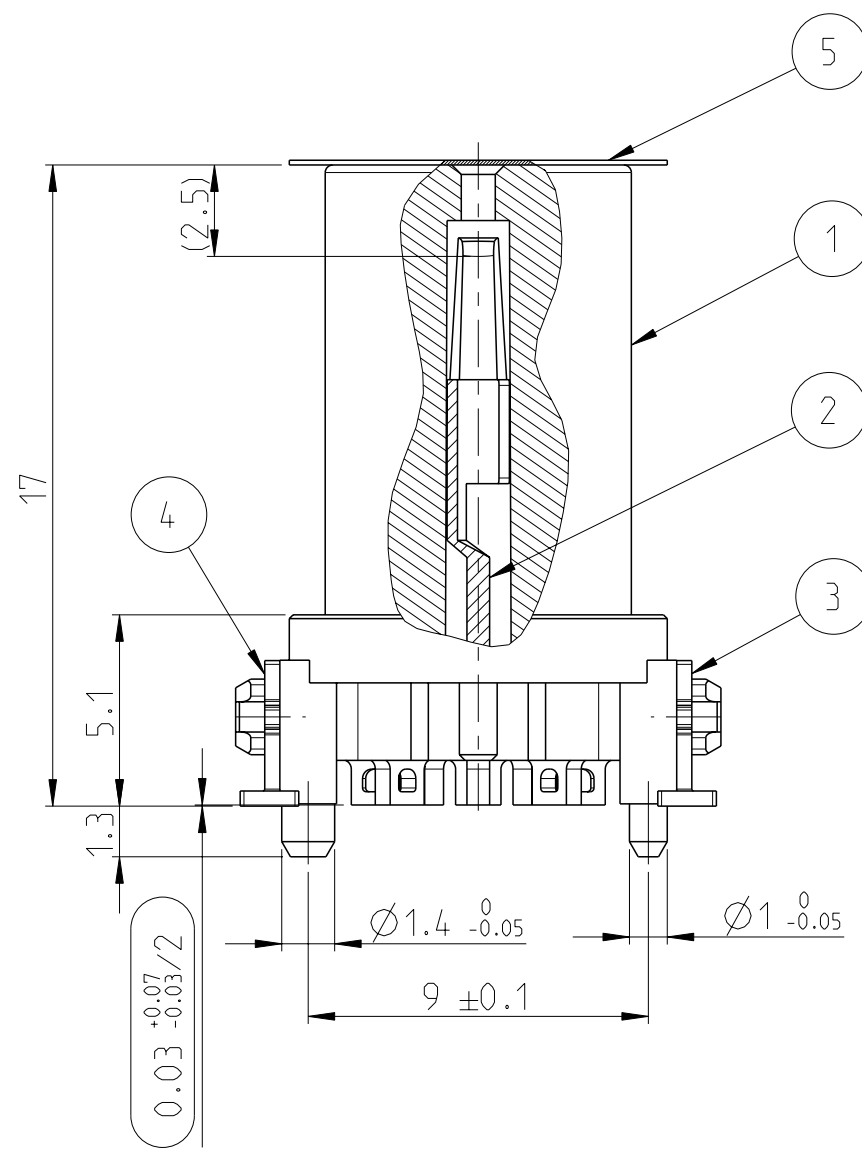

- DRAWING SPECIFICATION ACCORDING TO 5_3-16-DOC-1806-00915
 - COPLANARITY OF ALL CLIPS $\leq 0.1\text{mm}$
- △ PART; 100 PCS. IN BUBBLE BAGS/BULK

QTY	DESCRIPTION	ITEM NO.
1	TAPE AND REEL	6
1	PAD	5
1	SOLDER CLIP LEFT	4
1	SOLDER CLIP RIGHT	3
8	PINS	2
1	HOUSING	1
454952-E	354131-E	254310-E
REV OF EACH ASSY NO. (WHEN BLANK, USE DWG. REV)		
PARTS LIST		

THIS DRAWING IS A CONTROLLED DOCUMENT.

DIMENSIONS: mm	TOLERANCES UNLESS OTHERWISE SPECIFIED: ISO 8015	DWN: N. K. NIKHIL 17AUG2023	
	0 PLC ±	CHK: M. SZELAG 19AUG2023	
	1 PLC ±	APVD: J. DE BRUIJN 19AUG2023	
	2 PLC ±	PRODUCT SPEC: 108-94887	
MATERIAL: -	FINISH: -	APPLIC. SPEC: 114-94781	NAME: M12 FEMALE, A CODE, 8P, 17MM SMT
CUSTOMER DRAWING		WEIGHT: -	SIZE: A2 CAGE CODE: 00779 DRAWING NO: C=254310-E RESTRICTED TO: -
SCALE: 5:1		SHEET: 1 OF 1	REV: J1

Printed on 26 Dec 2023 16:54 (India Standard Time) from TES25293