

## 27 SERIES

- HALOGEN CYCLE G4 BI-PIN NON-GROUNDED LAMPHOLDERS
- 6" WIRE LEADS OR 0.110" TAB TERMINALS
- HEAT RESISTANT CERAMIC HOUSING
- MAXIMUM RATING: 50 WATTS, 14 VOLTS
- UL AND CSA RECOGNIZED • UL FILE E20356 • CSA FILE LR 15284-23

### Overview

The 27 Series lampholders are constructed with a high heat resistant ceramic housing and two 6" wire leads or two 0.110" tab terminals. Standard units feature an eyeletted housing with a clearance hole through the eyelet to accept a #1 screw. Lampholders are non-grounded and designed for use in low voltage halogen lamp applications that use G4 halogen cycle bi-pin lamps.

### Specifications

**Housing:** ceramic.

**Contacts:** stainless steel.

**Wire leads:**

**6" leads:** #18 AWG, white, UL3135, UL/CSA rated 200° C, stripped 1/2". Non-grounded units are supplied with two 6" wire leads. Custom wire lengths, stripping, termination and wire types are also available.

**Terminals:**

**0.110" tab:** bright electro tinned stainless steel, 0.110" length x 0.018" thick. Non-grounded units are supplied with two 0.110" tab terminals.

**Mounting:**

**Brackets:** .025" to .032" zinc plated steel. Custom brackets and plating types are available.

**Maximum rating:** 50 Watts, 14 Volts.

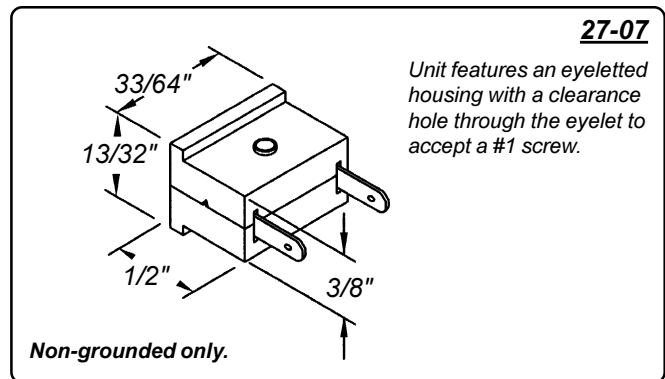
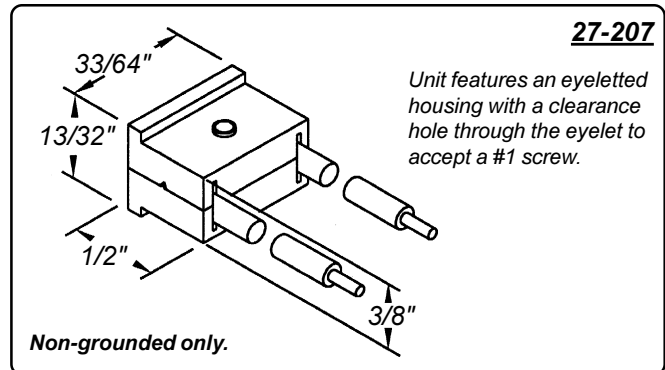

**Can't find it here? We have many more standard and custom solutions.**

The items in this catalog are only a small representative sample of the complete LC&D-Leecraft product line. We manufacture many additional products, which are not shown in this catalog due to space constraints.

Custom products can also be designed uniquely for you by our Technical Support Professionals. Starting from your ideas and specifications, we work with your personnel to develop timely and cost effective solutions for your miniature lighting needs.

LC&D Technical Support Services are provided without charge, and may include designs, prototypes, and pre-production samples.

For further information, phone Customer Service at 954-425-0123, or complete the "Fast FAX Technical Support Inquiry" form located in the Appendix, page A-1.

**27 Series**  
**Maximum Rating: 50 Watts, 14 Volts**  
**UL & CSA Listed • Non-Grounded**

**Heat Resistant Ceramic Housing**  
**0.110" Tab Terminals or**  
**6" Wire Leads**

