



# METAL OXIDE VARISTORS TNR™

## SV Series

Upgrade!



Our newly developed TNR SV series is to prevent from being caught fire even very high surge energy is applied. Thus electric appliance using TNR SV series can be much safer like TNR SE series.

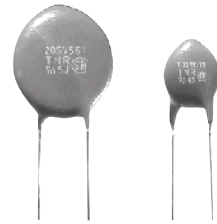

### ◆FEATURES

- Little scatter at the destruction under over voltage.
- Environmental characteristics (Upgrade)
  - High temperature operating : 125°C, 1000hours
  - Damp heat operating : 85°C, 85%RH, 1000hours
  - Temperature cycle : -40°C ⇔ +125°C, 1000cycles
- Coating resin doesn't burn under the flammability test of UL.
- Material of Coating resin:UL94V-0 and Halogen free
- UL, CSA and VDE recognized components
  - UL1449 File : E323623
  - CSA File : 097864 0 000
  - VDE File : 118623
  - CQC File number varies according to a part number. Please refer to us.
- AEC-Q200 compliant : φ 10~ φ 14 (220V~680V) Please contact Chemi-con for more details, test data, information.

### ◆APPLICATIONS

- Protection for semiconductors from over voltage.
  - Protection for electronic instruments from lightning surge.
  - Absorption of on-off surge from motors and relays.
- Operating Temperature Range : -40 ~ +125°C  
Storage Temperature Range : -50 ~ +150°C

### ◆PART NUMBERING SYSTEM

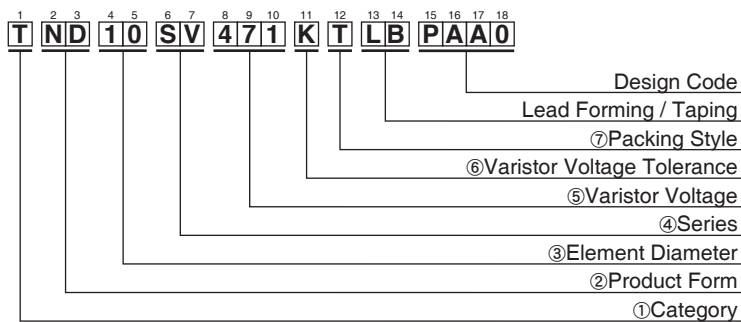

①Category	
T	Metal Oxide Varistor TNR

②Product Form	
ND	Disk Type

③Element Diameter	
05	φ5 mm
07	φ7 mm
10	φ10 mm
12	φ12 mm
14	φ14 mm
20	φ20 mm

④Series	
SV	SV series

⑤Varistor Voltage
The first two digits are significant figures and the third one denotes the number of following zeros.

⑥Varistor Voltage Tolerance	
K	±10%

⑦Packing Style	
B	Bulk
T	Taping

### ◆CAUTIONS and WARNINGS

Varistors may be short-circuit or be destroyed, in case of absorbing over rating voltage or over rating surge. Please connect a current fuse or a circuit breaker in series with varistors.



SV Series

	◇	□
Standard	A	417
φ 10 IEC 62368-1:2018 G.8.1 conforming product	S	S417

◆RATING AND CHARACTERISTICS

Part Number	Previous Part Number	Maximum Ratings					Max. Clamping Voltage (A)	Max. Clamping Voltage (V)	Capacitance Typical @1kHz (pF)	Varistor Voltage V <sub>CmA</sub> 5SV : V <sub>0.1mA</sub> (V)	Thickness T MAX.			
		Max. Allowable Voltage		Max. Peak Current	Max. Energy	Rated Wattage								
		AC (Vrms)	DC (V)	8/20us (A)	2ms (J)	(W)								
TND05SV221KTBAAAA0	TNR5SV221K-T25	140	180	800A/1time 600A/2time	6.5	0.1	5	380	110	220 (198 to 242)	5.0			
TND05SV241KTBAAAA0	TNR5SV241K-T25	150	200		7.5			415	100	240 (216 to 264)	5.1			
TND05SV271KTBAAAA0	TNR5SV271K-T25	175	225		8.0			475	90	270 (247 to 303)	5.4			
TND05SV431KTBAAAA0	TNR5SV431K-T25	275	350		13.5			745	70	430 (387 to 473)	6.2			
TND05SV471KTBAAAA0	TNR5SV471K-T25	300	385		15.0			810	60	470 (423 to 517)	6.4			
TND07SV221KTBAAAA0	TNR7SV221K-T25	140	180	1,750A/1time 1,250A/2times	13.5	0.25	10	360	230	220 (198 to 242)	5.0			
TND07SV241KTBAAAA0	TNR7SV241K-T25	150	200		15			395	210	240 (216 to 264)	5.1			
TND07SV271KTBAAAA0	TNR7SV271K-T25	175	225		17			455	190	270 (247 to 303)	5.2			
TND07SV431KTBAAAA0	TNR7SV431K-T25	275	350		27.5			710	130	430 (387 to 473)	6.2			
TND07SV471KTBAAAA0	TNR7SV471K-T25	300	385		30			775	120	470 (423 to 517)	6.3			
TND07SV511KTBAAAA0	TNR7SV511K-T25	320	410		32			845	110	510 (459 to 561)	6.6			
TND10SV221KTLBPAA0	TNR10SV221K417-T71	140	180	3,500A/1time 2,500A/2times	27.5	0.4	25	360	450	220 (198 to 242)	5.4			
TND10SV241KTLBPAA0	TNR10SV241K417-T71	150	200		30			395	400	240 (216 to 264)	5.5			
TND10SV271KTLBPAA0	TNR10SV271K417-T71	175	225		35			455	350	270 (247 to 303)	5.7			
TND10SV431KTLBPAA0	TNR10SV431K417-T71	275	350		55			710	240	430 (387 to 473)	6.5			
TND10SV471KTLBP◇A0	TNR10SV471K□-T71	300	385		60			775	220	470 (423 to 517)	6.7			
TND10SV511KTLBP◇A0	TNR10SV511K□-T71	320	410		67			845	210	510 (459 to 561)	6.9			
TND10SV561KTLBP◇A0	TNR10SV561K□-T71	350	460		67			922	195	560 (504 to 616)	7.2			
TND10SV621KTLBP◇A0	TNR10SV621K□-T71	385	505		67			1025	180	620 (558 to 682)	7.5			
TND10SV681KTLBP◇A0	TNR10SV681K□-T71	420	560		67			1120	165	680 (612 to 748)	7.9			
TND10SV751KB00A◇A0	TNR10SV751K□	460	615		70			1240	150	750 (675 to 825)	8.2			
TND10SV821KB00A◇A0	TNR10SV821K□	510	670		80			1355	140	820 (738 to 902)	8.6			
TND10SV911KB00A◇A0	TNR10SV911K□	550	745		90			1500	125	910 (819 to 1001)	9.1			
TND10SV102KB00A◇A0	TNR10SV102K□	625	825		100			1650	115	1000 (900 to 1100)	9.6			
TND12SV431KTLBPAA0	TNR12SV431K417-T71	275	350		4,200A/1time 3,000A/2times			55	0.4	25	710	375	430 (387 to 473)	6.5
TND12SV471KTLBPAA0	TNR12SV471K417-T71	300	385					60			775	345	470 (423 to 517)	6.7
TND12SV511KTLBPAA0	TNR12SV511K417-T71	320	410	67		845	330	510 (459 to 561)			6.9			
TND12SV561KTLBPAA0	TNR12SV561K417-T71	350	460	67		922	305	560 (504 to 616)			7.2			
TND12SV621KTLBPAA0	TNR12SV621K417-T71	385	505	67		1025	280	620 (558 to 682)			7.5			
TND12SV681KTLBPAA0	TNR12SV681K417-T71	420	560	67		1120	260	680 (612 to 748)			7.9			
TND12SV751KB00AAA0	TNR12SV751K	460	615	70		1240	235	750 (675 to 825)			8.4			
TND12SV821KB00AAA0	TNR12SV821K	510	670	80		1355	220	820 (738 to 902)			8.8			
TND12SV911KB00AAA0	TNR12SV911K	550	745	90		1500	195	910 (819 to 1001)			9.2			
TND12SV102KB00AAA0	TNR12SV102K	625	825	100		1650	180	1000 (900 to 1100)			9.7			
TND14SV221KTLBPAA0	TNR14SV221K417-T71	140	180	6,000A/1time 5,000A/2times		55	0.6	50			360	850	220 (198 to 242)	5.4
TND14SV241KTLBPAA0	TNR14SV241K417-T71	150	200			60					395	800	240 (216 to 264)	5.5
TND14SV271KTLBPAA0	TNR14SV271K417-T71	175	225		70	455			700	270 (247 to 303)	5.7			
TND14SV431KTLBPAA0	TNR14SV431K417-T71	275	350		110	710			460	430 (387 to 473)	6.5			
TND14SV471KTLBPAA0	TNR14SV471K417-T71	300	385		125	775			420	470 (423 to 517)	6.7			
TND14SV511KTLBPAA0	TNR14SV511K417-T71	320	410		136	845			390	510 (459 to 561)	6.9			
TND14SV561KTLBPAA0	TNR14SV561K417-T71	350	460		5,000A/1time 4,500A/2times	136			922	360	560 (504 to 616)	7.2		
TND14SV621KTLBPAA0	TNR14SV621K417-T71	385	505			136			1025	330	620 (558 to 682)	7.5		
TND14SV681KTLBPAA0	TNR14SV681K417-T71	420	560			136			1120	310	680 (612 to 748)	7.9		
TND14SV751KB00AAA0	TNR14SV751K	460	615			150			1240	280	750 (675 to 825)	8.4		
TND14SV821KB00AAA0	TNR14SV821K	510	670	165		1355	250	820 (738 to 902)	8.8					
TND14SV911KB00AAA0	TNR14SV911K	550	745	180	1500	230	910 (819 to 1001)	9.2						
TND14SV102KB00AAA0	TNR14SV102K	625	825	200	1650	210	1000 (900 to 1100)	9.7						
TND20SV221KB00AAA0	TNR20SV221K	140	180	10,000A/1time 7,000A/2times	110	1.0	100	360	2500	220 (198 to 242)	5.4			
TND20SV241KB00AAA0	TNR20SV241K	150	200		120			395	2300	240 (216 to 264)	5.5			
TND20SV271KB00AAA0	TNR20SV271K	175	225		135			455	2000	270 (247 to 303)	5.7			
TND20SV431KB00AAA0	TNR20SV431K	275	350		215			710	1300	430 (387 to 473)	6.5			
TND20SV471KB00AAA0	TNR20SV471K	300	385		250			775	1200	470 (423 to 517)	6.7			
TND20SV511KB00AAA0	TNR20SV511K	320	410		273			845	1100	510 (459 to 561)	6.9			
TND20SV561KB00AAA0	TNR20SV561K	350	460		7,500A/1time 6,500A/2times			273	922	560 (504 to 616)	7.2			
TND20SV621KB00AAA0	TNR20SV621K	385	505					273	1025	900	620 (558 to 682)	7.6		
TND20SV681KB00AAA0	TNR20SV681K	420	560					273	1120	830	680 (612 to 748)	7.9		
TND20SV751KB00AAA0	TNR20SV751K	460	615					300	1240	750	750 (675 to 825)	8.4		
TND20SV821KB00AAA0	TNR20SV821K	510	670					325	1355	700	820 (738 to 902)	8.8		
TND20SV911KB00AAA0	TNR20SV911K	550	745					360	1500	620	910 (819 to 1001)	9.2		
TND20SV102KB00AAA0	TNR20SV102K	625	825	400	1650	560	1000 (900 to 1100)	9.7						

Product specifications in this catalog are subject to change without notice. Request our product specifications before purchase and/or use. Please use our products based on the information contained in this catalog and product specifications.

# SV Series

## ◆ DIMENSIONS [mm]

● Refer to the table below for standard packing styles.

Rating	TND05SV	TND07SV	TND10SV	TND12SV	TND14SV	TND20SV
221K to 511K*	Taping	Taping	Taping	Taping	Taping	Bulk
561K to 681K	—	—	Taping	Taping	Taping	Bulk
751K to 102K	—	—	Bulk	Bulk	Bulk	Bulk

\* The rating range for TND05SV is 221K to 471K

· TND05SV and TND07SV are taping models.

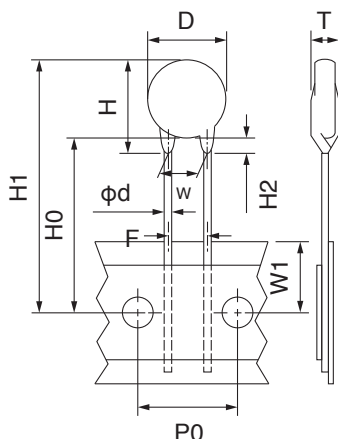

Symbol	5SV	7SV
D	7.5Max	9.0 Max.
H	13.0Max	14.0 Max.
T	Ref. to RATINGS	
φd	0.6±0.05	
P0	12.7±0.3	
W1	9.0±0.5	
W	5.0±1.0	
F	5.0±0.8	
H0	20.0± <sup>1.5</sup> / <sub>1.0</sub>	
H1	31.5 Max.	32.5 Max.
H2	5.0 Max.	

· Taping specifications of TND10SV/TND12SV/TND14SV

Taping Code : TLB

Symbol	10SV	12SV	14SV
D	12.5 MAX.	14.5 MAX.	16.5 MAX.
φd	0.8±0.05	←	←
P	15.0±1.0	15.0±1.0	30.0±1.0
P0	15.0±0.3	←	←
φD0	4.0±0.2	←	←
P1	3.75±0.5	←	←
W1	9.0±0.5	←	←
F	7.5±0.8	←	←
Δh	0±2.0	←	←
ΔP	0±1.3	←	←
W	18.0 <sup>+1.0</sup> / <sub>-0.5</sub>	←	←
W0	5.0 MIN.	←	←
W2	3.0 MAX.	←	←
t	0.6±0.3	←	←
H	20.0 MAX.	23.5 MAX	25.0 MAX.
H0	19.0±1.0	←	←
H1	46.5 MAX.	←	←
J	6.0 MAX.	←	←

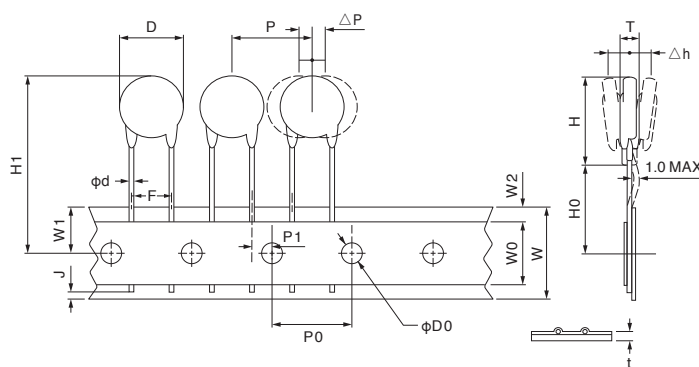

# SV Series

## ◆ DIMENSION

Unit : mm

Part Number	D MAX.	H MAX.	L MIN.	φd ±0.05	W ±1.0	E ±1.0
TND10SV751KB00A◇A0	13.0	18.0	20.0	0.8	7.5	3.1
TND10SV821KB00A◇A0						3.4
TND10SV911KB00A◇A0						3.7
TND10SV102KB00A◇A0						4.0
TND12SV751KB00AAA0	15.0	20.0				3.1
TND12SV821KB00AAA0						3.4
TND12SV911KB00AAA0						3.7
TND12SV102KB00AAA0						4.0
TND14SV751KB00AAA0	16.5	21.5			3.3	
TND14SV821KB00AAA0					3.5	
TND14SV911KB00AAA0					3.9	
TND14SV102KB00AAA0					4.2	
TND20SV221KB00AAA0	22.5	27.5	20.0	0.8	10.0	1.3
TND20SV241KB00AAA0						1.4
TND20SV271KB00AAA0						1.5
TND20SV431KB00AAA0						2.1
TND20SV471KB00AAA0						2.3
TND20SV511KB00AAA0						2.4
TND20SV561KB00AAA0						2.6
TND20SV621KB00AAA0						2.9
TND20SV681KB00AAA0	3.1					
TND20SV751KB00AAA0	23.5	29.5			3.4	
TND20SV821KB00AAA0					3.6	
TND20SV911KB00AAA0					4.0	
TND20SV102KB00AAA0					4.3	

## ◆ MARKING

EX)

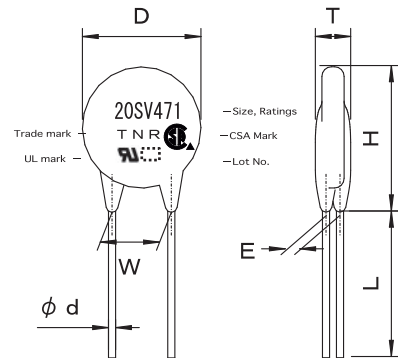

•TND10SV/TND12SV/TND14SV with the rating 751K or above and TND20SV are packaged in bulk.

## Lead forming Type

Part No.	TND10SV***KBESA ◇ A0	TND12SV***KBESAAA0	TND14SV***KBESAAA0	TND20SV***KBESAAA0
	◇ : P80 See the above section.			
Forming Code	BES (310)			
D	Refer to each spec (see the above table).			
T	Refer to each spec (see the above table).			
H	23.0 Max.	25.0 Max.	26.5 Max.	33.5 Max.
L	5.0 ± 1.0	←	←	←
W	7.5 ± 1.0	←	←	10.0 ± 1.0
φd	0.8 ± 0.05	←	←	←
C	2.0 ± 0.5	←	←	←
E	Refer to each spec (see the above table).			

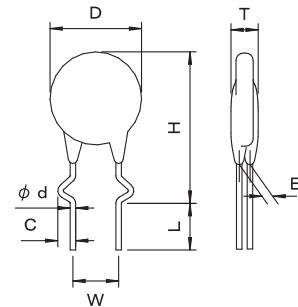

## ◆ V-I CURVE

V-I characteristics and PULSE LIFE TIME RATINGS are same as those of V series.

Please see V-I CURVE and PULSE LIFE TIME RATINGS of V series.

CROSS REFERENCE TABLE (Common to standard product and IEC 62368-1:2014 G.8.2 conforming product)

TNR SV SERIES	TNR V SERIES	V-I CURVE GO TO REF. PAGE	PULSE LIFE TIME RATINGS GO TO REF. PAGE
TND05SV221K to TND05SV471K	TND05V-221K to TND05V-471K	P.61	P.76
TND07SV221K to TND07SV511K	TND07V-221K to TND07V-511K	P.63	P.77
TND10SV221K to TND10SV102K	TND10V-221K to TND10V-102K	P.67	P.78
TND12SV431K to TND12SV102K	TND12V-431K to TND12V-102K	P.69	P.78 to 79
TND14SV221K to TND14SV102K	TND14V-221K to TND14V-102K	P.71	P.79
TND20SV221K to TND20SV102K	TND20V-221K to TND20V-102K	P.73	P.80



### ◆GENERAL SPECIFICATIONS

Item	Test Conditions	Specifications						
Standard Test Condition	20±15°C, 85%RH Max.	-						
Varistor Voltage	The voltage between the two terminals measured at CmA DC is called Varistor Voltage. The measurement shall be made as fast as possible to avoid heat affection.	Satisfy the specification						
	<table border="1"> <thead> <tr> <th>Type</th> <th>Current CmA</th> </tr> </thead> <tbody> <tr> <td>5SV</td> <td>0.1</td> </tr> <tr> <td>Others</td> <td>1.0</td> </tr> </tbody> </table>		Type	Current CmA	5SV	0.1	Others	1.0
	Type		Current CmA					
5SV	0.1							
Others	1.0							
Maximum Allowable Voltage	Maximum continuous AC voltage (50 to 60Hz AC) and maximum DC voltage which can be applied.	Satisfy the specification						
Maximum Peak Surge Current	Maximum surge current (8/20µs pulse wave to be applied once, or twice, 5 minutes apart) for varistor voltage change within ±10% of the initial value.	Satisfy the specification						
Energy Rating	Maximum energy (2 ms. square wave to be applied once) for varistor voltage change within ±10% of the initial value.	Satisfy the specification						
Rated Wattage	Maximum power (50 to 60Hz/AC power to be applied for 1000 hours at 125°C) for varistor voltage change within ±10% of the initial value.	Satisfy the specification						
Maximum Clamping Voltage	Maximum voltage across varistor when 8/20µs rated current surge is applied.	Satisfy the specification						
Capacitance	Varistor's capacitance at 1kHz, standard test condition.	For reference only.						
Voltage Temperature Coefficient	$\frac{VC \text{ at } 125^{\circ}\text{C} - VC \text{ at } 25^{\circ}\text{C}}{VC \text{ at } 25^{\circ}\text{C}} \times \frac{1}{100} \times 100 (\%/^{\circ}\text{C})$ <p style="text-align: right;">VC : Actual varistor voltage</p>	Within ±0.05%/°C (≤681K) Within ±0.10%/°C (751K≤)						
Insulation	Short circuit the two leads of varistor, and put the varistor body into metal balls (1.6mm diameter) leaving 2mm resin coating outside. Then, apply 2.5kVrms between the leads and the metal balls for 60±5 sec.	The varistor shall withstand with no abnormality.						

### ◆ENVIRONMENTAL CHARACTERISTICS

Item	Test Conditions	Specifications
High Temperature Storage (Dry heat)	The specimen shall be subjected 150±2°C for 1000±12 hours without load.	ΔV CmA/V CmA ≤ ±10%
Low Temperature Storage	The specimen shall be subjected -40±2°C for 1000±12 hours without load.	ΔV CmA/V CmA ≤ ±5%
Damp heat (Humidity)	The specimen shall be subjected to 85±2°C, 80 to 85%RH for 1000±12 hours without load.	ΔV CmA/V CmA ≤ ±5%
Temperature Cycle	The temperature cycle shown below shall be repeated 1000 cycles. -40±3°C, 30 minutes ↔ +125±2°C, 30 minutes	ΔV CmA/V CmA ≤ ±5% No remarkable damage
High Temperature Operating	The specimen shall be subjected to 125±2°C with the maximum allowable voltage for 1000±12 hours.	ΔV CmA/V CmA ≤ ±10%
Damp heat Operating	The specimen shall be subjected to 85±2°C, 80 to 85%RH with the maximum allowable voltage for 1000±12 hours.	ΔV CmA/V CmA ≤ ±10%

Varistor voltage change of forward direction shall be measured in the test of unipolar surge life and DC load life.

Varistor voltage change is measured after stored at Standard Test Conditions for 1 to 2 hours.



### ◆MECHANICAL CHARACTERISTICS

Item	Test Conditions	Specifications												
<b>Resistance to Soldering Heat</b>	<p>After V CmA is measured at room temperature, each lead shall be dipped into a solder bath at a temperature of 350±10°C to a point 2.0 to 2.5 mm from the root of the lead, and be held there for 3<sup>+1</sup><sub>0</sub> seconds, and then be stored at room temperature for 1 to 2 hours. Then, V CmA shall be examined. (Conform to JIS C 5102)</p> <p>or</p> <p>After V CmA is measured at room temperature, each lead shall be dipped into a solder bath at a temperature of 260±10°C to a point 2.0 to 2.5 mm from the root of the lead, be held there for 10±1 seconds, and then be stored at room temperature for 1 to 2 hours. Then, V CmA shall be examined. (Conform to JIS C 5102)</p>	<p><math>\Delta V \text{ CmA} / V \text{ CmA} \leq \pm 5\%</math> No remarkable damage</p>												
<b>Solderability</b>	<p>Each lead shall be dipped into a methanol solution (about 25%) of rosin for 5 to 10 sec. Then each lead shall be dipped into a solder.</p> <table border="1"> <tr> <td>Solder</td> <td>Pb free (Sn-3.0Ag-0.5Cu)</td> <td>Eutectic (Sn/Pb)</td> </tr> <tr> <td>Solder Temp.</td> <td>245±5°C</td> <td>235±5°C</td> </tr> <tr> <td>Dipping Time</td> <td colspan="2">2±0.5sec.</td> </tr> <tr> <td>Dipping Depth</td> <td colspan="2">1.5 to 2.0mm (from the body)</td> </tr> </table>	Solder	Pb free (Sn-3.0Ag-0.5Cu)	Eutectic (Sn/Pb)	Solder Temp.	245±5°C	235±5°C	Dipping Time	2±0.5sec.		Dipping Depth	1.5 to 2.0mm (from the body)		At least, 95% of the leads shall be covered with solder uniformly.
Solder	Pb free (Sn-3.0Ag-0.5Cu)	Eutectic (Sn/Pb)												
Solder Temp.	245±5°C	235±5°C												
Dipping Time	2±0.5sec.													
Dipping Depth	1.5 to 2.0mm (from the body)													
<b>Lead Pull Strength</b>	<p>Fix varistor body, and suspend specified weight toward direction of lead axis.</p> <table border="1"> <tr> <td>Lead diameter</td> <td>Force</td> </tr> <tr> <td>φ0.8mm</td> <td>10N</td> </tr> </table>	Lead diameter	Force	φ0.8mm	10N	<p>No abnormality such as disconnection. <math>\Delta V \text{ CmA} / V \text{ CmA} \leq \pm 5\%</math></p>								
Lead diameter	Force													
φ0.8mm	10N													
<b>Lead Bend Strength</b>	<p>The varistor shall be secured with its terminal kept vertical and the force specified below shall be applied in the axial direction. The terminal shall gradually be bend by 90 in one direction then back to original position. The damage of the terminal shall be visually examined.</p> <table border="1"> <tr> <td>Type</td> <td>Lead Diameter</td> <td>Force</td> </tr> <tr> <td>5SV, 7SV</td> <td>0.6mm</td> <td>10N</td> </tr> <tr> <td>10SV, 12SV, 14SV, 20SV</td> <td>0.8mm</td> <td>10N</td> </tr> </table>	Type	Lead Diameter	Force	5SV, 7SV	0.6mm	10N	10SV, 12SV, 14SV, 20SV	0.8mm	10N	No remarkable damage as remarkable the inner ceramic element or terminal open.			
Type	Lead Diameter	Force												
5SV, 7SV	0.6mm	10N												
10SV, 12SV, 14SV, 20SV	0.8mm	10N												
<b>Vibration</b>	<p>Mount varistor body on vibrator, and conduct the following vibration test.</p> <p>Peak-to-Peak amplitude : 1.5mm Vibration frequency range : 10 to 55Hz Sweeping time: ∧ Approximately one minute for 10Hz → 55Hz → 10Hz Direction and duration of vibration : Three directions of X, Y, and Z. 2 hours each. 6 hours total.</p>	<p>No remarkable appearance abnormality. <math>\Delta V \text{ CmA} / V \text{ CmA} \leq \pm 5\%</math></p>												
<b>Flammability test</b>	<p>The varistor shall be subjected 60 sec. applications of test flame.</p> <p>Burnar : Bunsen gas burner 9000kcal / m<sup>3</sup> Diameter of flame nozzle : φ9.5mm Position : The specimen shall be fixed horizontal. Point of application shall be approximately center of the specimen.</p>	No catching fire, and no flaming drops.												



## SV Series Low varistor voltage

New!

RoHS2  
Compliant

AEC-  
Q200

High  
Temperature

By using the resin properties of the SV series to a low varistor voltage products, it has achieved a high heat resistance and temperature cycle resistance. Low varistor voltage SV series is for automotive in compliance with the AEC-Q200.

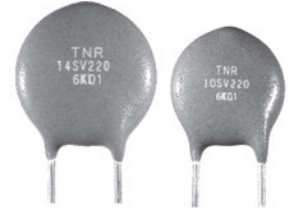

### ◆FEATURES

- High temperature operating : 1,000 hours at 125°C.
- Damp heat operating : 1,000 hours at 85°C/85%RH.
- Temperature cycle : -40°C ↔ +125°C, 1000cycle.
- Material of Coating resin:UL94V-0 and Halogen free.
- AEC-Q200 compliant : Please contact Chemi-con for more details, test data, information.

### ◆APPLICATIONS

- Absorption of automotive load dump surge.
- Absorption of ignition-off surge.
- Absorption of switching surge of horn, motor, and relay.
- Protection of automotive electronics and semi conductors.

Operating Temperature Range : -40 ~ +125°C  
Storage Temperature Range : -50 ~ +150°C

### ◆PART NUMBERING SYSTEM

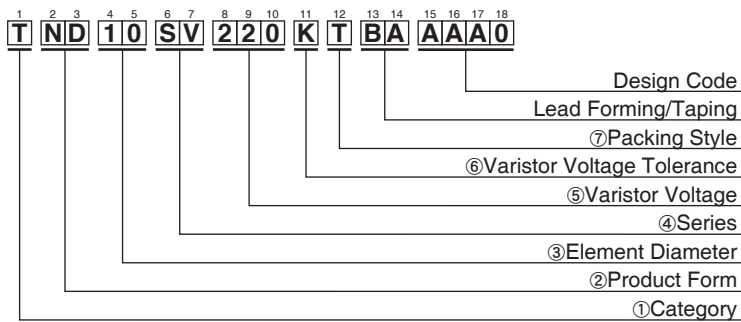

①Category	
T	Metal Oxide Varistor TNR

②Product Form	
ND	Disk Type

③Element Diameter	
5	φ5mm
7	φ7mm
10	φ10mm
14	φ14mm
20	φ20mm

④Series	
SV	SV series

⑤Varistor Voltage	
The first two digits are significant figures and the third one denotes the number of following zeros.	

⑥Varistor Voltage Tolerance	
K	±10%

⑦Packing Style	
B	Bulk
T	Taping



# SV Series Low varistor voltage

## ◆RATING AND CHARACTERISTICS

Part Number	Previous Part Number	Maximum Ratings						Max. Clamping Voltage		Capacitance Typical @1kHz (pF)	Varistor Voltage V <sub>CmA</sub> 5SV : V <sub>0.1mA</sub> (V)	Thickness T MAX.
		Max. Allowable Voltage		Max. Peak Current	Max. Energy	Max. Applicable voltage for short period/5 minutes	Rated Wattage	(A)	(V)			
		AC(Vrms)	DC(V)	8/20μs(A)	2ms(J)	DC(V)	(W)					
TND05SV220KTBAAAA0	TNR5SV220K-T25	12	16	125A /2 times	0.5	24	0.01	1	48	3600	22 (20~24)	5.0
TND05SV270KTBAAAA0	TNR5SV270K-T25	15	19		0.7	29			60	3100	27 (24~30)	5.0
TND05SV330KTBAAAA0	TNR5SV330K-T25	18	24		0.8	36			73	2500	33 (30~36)	5.5
TND05SV390KTBAAAA0	TNR5SV390K-T25	22	28		0.9	42			86	2300	39 (35~43)	5.0
TND05SV470KTBAAAA0	TNR5SV470K-T25	26	34		1.1	50			104	2000	47 (42~52)	5.0
TND05SV560KTBAAAA0	TNR5SV560K-T25	30	42		1.3	50			123	1700	56 (50~62)	5.5
TND05SV680KTBAAAA0	TNR5SV680K-T25	40	55	1.6	65	150	1500	68 (61~75)	5.5			
TND07SV220KTBAAAA0	TNR7SV220K-T25	12	16	250A /2 times	1.1	24	0.02	2.5	43	5400	22 (20~24)	5.0
TND07SV270KTBAAAA0	TNR7SV270K-T25	15	19		1.3	29			53	4800	27 (24~30)	5.0
TND07SV330KTBAAAA0	TNR7SV330K-T25	18	24		1.6	36			65	3900	33 (30~36)	5.5
TND07SV390KTBAAAA0	TNR7SV390K-T25	22	28		1.9	42			77	3600	39 (35~43)	5.0
TND07SV470KTBAAAA0	TNR7SV470K-T25	26	34		2.3	50			93	3300	47 (42~52)	5.0
TND07SV560KTBAAAA0	TNR7SV560K-T25	30	42		2.7	50			110	2900	56 (50~62)	5.5
TND07SV680KTBAAAA0	TNR7SV680K-T25	40	55	3.3	65	135	2600	68 (61~75)	5.5			
TND10SV220KTBAAAA0	TNR10SV220K-T25	12	16	500A /2 times	2.6	24	0.05	5	43	12000	22 (20~24)	6.0
TND10SV270KTBAAAA0	TNR10SV270K-T25	15	19		3.2	29			53	11000	27 (24~30)	6.0
TND10SV330KTBAAAA0	TNR10SV330K-T25	18	24		4.0	36			65	8500	33 (30~36)	6.5
TND10SV390KTBAAAA0	TNR10SV390K-T25	22	28		4.7	42			77	7600	39 (35~43)	6.0
TND10SV470KTBAAAA0	TNR10SV470K-T25	26	34		5.6	50			93	6800	47 (42~52)	6.0
TND10SV560KTBAAAA0	TNR10SV560K-T25	30	42		6.7	50			110	6000	56 (50~62)	6.5
TND10SV680KTBAAAA0	TNR10SV680K-T25	40	55	8.2	65	135	5400	68 (61~75)	6.5			
TND14SV220KTBAAAA0	TNR14SV220K-T25	12	16	1000A /2 times	5.3	24	0.1	10	43	23000	22 (20~24)	6.0
TND14SV270KTBAAAA0	TNR14SV270K-T25	15	19		6.5	29			53	21000	27 (24~30)	6.0
TND14SV330KTBAAAA0	TNR14SV330K-T25	18	24		7.9	36			65	17000	33 (30~36)	6.5
TND14SV390KTBAAAA0	TNR14SV390K-T25	22	28		9.4	42			77	16000	39 (35~43)	6.0
TND14SV470KTBAAAA0	TNR14SV470K-T25	26	34		11	50			93	14000	47 (42~52)	6.0
TND14SV560KTBAAAA0	TNR14SV560K-T25	30	42		13	50			110	13000	56 (50~62)	6.5
TND14SV680KTBAAAA0	TNR14SV680K-T25	40	55	16	65	135	11000	68 (61~75)	6.5			
TND20SV220KB00AAA0	TNR20SV220K	12	16	2000A /2 times	14	24	0.2	20	43	56000	22 (20~24)	6.0
TND20SV270KB00AAA0	TNR20SV270K	15	19		17	29			53	48000	27 (24~30)	6.0
TND20SV330KB00AAA0	TNR20SV330K	18	24		21	36			65	41000	33 (30~36)	6.5
TND20SV390KB00AAA0	TNR20SV390K	22	28		25	42			77	36000	39 (35~43)	6.0
TND20SV470KB00AAA0	TNR20SV470K	26	34		30	50			93	33000	47 (42~52)	6.0
TND20SV560KB00AAA0	TNR20SV560K	30	42		36	50			110	29000	56 (50~62)	6.5
TND20SV680KB00AAA0	TNR20SV680K	40	55	44	65	135	26000	68 (61~75)	6.5			

## ◆DIMENSION

TND05SV/TND07SV/TND10SV/TND14SV : Taping product is normal specifications.

Taping Code : TBA (T25) Unit : mm

Symbol	5SV	7SV	10SV	14SV
D	8.0 Max.	9.0 Max.	12.0 Max.	16.0 Max.
φd	0.6±0.05	←	0.8±0.05	←
P	12.7±1.0	←	25.4±1.0	←
P0	12.7±0.3	←	12.7±0.3	←
φD0	4.0±0.2	←	4.0±0.2	←
P1	3.85±0.7	←	2.6±0.5	←
P2	6.35±1.3	←	←	←
W1	9.0±0.5	←	9.0±0.5	←
F	5.0±0.8	←	←	←
F0	-	-	7.5±0.8	←
F1	-	-	5.0 Nom.	←
Δh	0±2.0	←	0±2.0	←
ΔP	0±1.0	←	0±1.0	←
W	18.0 <sup>+1.0</sup> <sub>-0.5</sub>	←	18.0 <sup>+1.0</sup> <sub>-0.5</sub>	←
W0	5.0 Min.	←	5.0 Min.	←
t1	0.6±0.3	←	0.6±0.3	←
t2	1.5 Max.	←	1.5 Max.	←
W2	3.0 Max.	←	3.0 Max.	←
H0	20.0 <sup>+1.5</sup> <sub>-1.0</sub>	←	19.0 Min.	←
H	11.0 Max.	12.0 Max.	17.0 Max.	20.0 Max.
H1	29.0 Max.	30.0 Max.	41.5 Max.	43.5 Max.
H2	3.0 Max.	←	5.0 Max.	←
J	6.0 Max.	←	6.0 Max.	←
L	11.0 Max.	←	-	-

### ●TND05SV/TND07SV

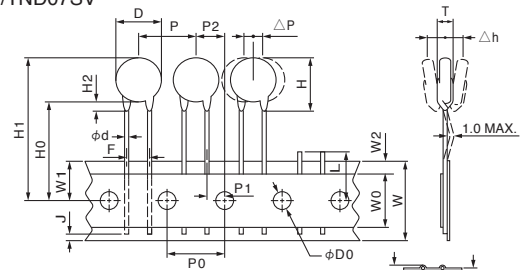

### ●TND10SV/TND14SV

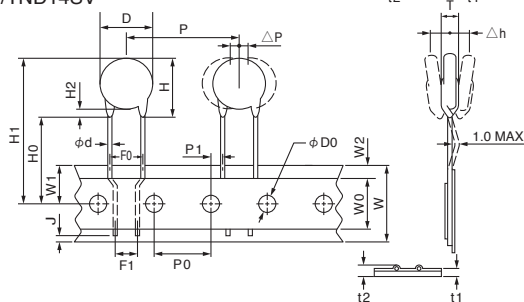



# SV Series Low varistor voltage

**◆DIMENSION**

TND20SV : Bulk only

Straight lead Type

Unit : mm

Part Number	D MAX.	H MAX.	L MIN.	$\phi d$ $\pm 0.05$	W $\pm 1.0$	E $\pm 1.0$
TND20SV220KB00AAA0	22.5	27.0	20.0	0.8	10	1.2
TND20SV270KB00AAA0						1.4
TND20SV330KB00AAA0						1.6
TND20SV390KB00AAA0						1.3
TND20SV470KB00AAA0						1.5
TND20SV560KB00AAA0						1.7
TND20SV680KB00AAA0						2.0

**◆MARKING**

EX)

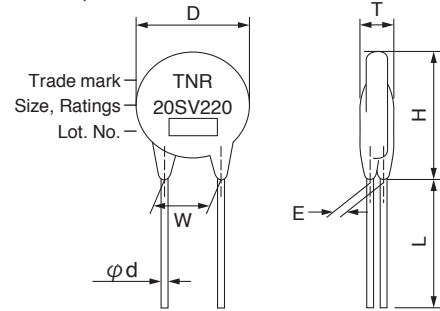
**Lead forming Type**

Part No.	TND20SV***KBESAAA0
Forming Code	BES (310)
D	refer to each spec.
T	refer to each spec.
H	30.5 MAX.
L	5.0 $\pm$ 1.0
W	10.0 $\pm$ 1.0
$\phi d$	0.8 $\pm$ 0.05
C	2.0 $\pm$ 0.5
E	refer to each spec.

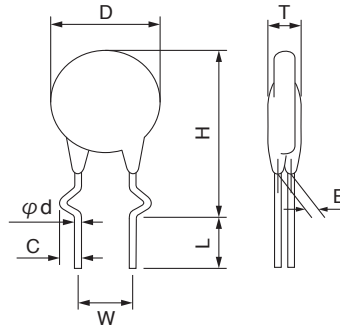
**◆V-I CURVE**

V-I characteristics and PULSE LIFE TIME RATINGS are same as those of V series.

Please see V-I CURVE and PULSE LIFE TIME RATINGS of V series.

**CROSS REFERENCE TABLE**

TNR SV SERIES	TNR V SERIES	V-I CURVE GO TO REF. PAGE	PULSE LIFE TIME RATINGS GO TO REF. PAGE
TND05SV220K	TND05V-220K	P.61	P.76
TND05SV270K	TND05V-270K		
TND05SV330K	TND05V-330K		
TND05SV390K	TND05V-390K		
TND05SV470K	TND05V-470K		
TND05SV560K	TND05V-560K		
TND05SV680K	TND05V-680K		
TND07SV220K	TND07V-220K	P.63	P.77
TND07SV270K	TND07V-270K		
TND07SV330K	TND07V-330K		
TND07SV390K	TND07V-390K		
TND07SV470K	TND07V-470K		
TND07SV560K	TND07V-560K		
TND07SV680K	TND07V-680K		
TND10SV220K	TND10V-220K	P.67	P.78
TND10SV270K	TND10V-270K		
TND10SV330K	TND10V-330K		
TND10SV390K	TND10V-390K		
TND10SV470K	TND10V-470K		
TND10SV560K	TND10V-560K		
TND10SV680K	TND10V-680K		
TND14SV220K	TND14V-220K	P.71	P.79
TND14SV270K	TND14V-270K		
TND14SV330K	TND14V-330K		
TND14SV390K	TND14V-390K		
TND14SV470K	TND14V-470K		
TND14SV560K	TND14V-560K		
TND14SV680K	TND14V-680K		
TND20SV220K	TND20V-220K	P.73	P.80
TND20SV270K	TND20V-270K		
TND20SV330K	TND20V-330K		
TND20SV390K	TND20V-390K		
TND20SV470K	TND20V-470K		
TND20SV560K	TND20V-560K		
TND20SV680K	TND20V-680K		



# SV Series Low varistor voltage

## ◆GENERAL SPECIFICATIONS

Item	Test Conditions	Specifications						
<b>Standard Test Condition</b>	20±15°C, 85%RH Max.	-						
<b>Varistor Voltage</b>	The voltage between the two terminals measured at CmA DC is called Varistor Voltage. The measurement shall be made as fast as possible to avoid heat affection.	Satisfy the specification						
	<table border="1"> <thead> <tr> <th>Type</th> <th>Current CmA</th> </tr> </thead> <tbody> <tr> <td>5SV</td> <td>0.1</td> </tr> <tr> <td>Others</td> <td>1.0</td> </tr> </tbody> </table>		Type	Current CmA	5SV	0.1	Others	1.0
	Type		Current CmA					
5SV	0.1							
Others	1.0							
<b>Maximum Allowable Voltage</b>	Maximum continuous AC voltage (50 to 60Hz/AC) and maximum DC voltage which can be applied.	Satisfy the specification						
<b>Maximum Peak Surge Current</b>	Maximum surge current (8/20µs pulse wave to be applied twice, 5 minutes apart) for varistor voltage change within ±10% of the initial value.	Satisfy the specification						
<b>Energy Rating</b>	Maximum energy (2ms square wave to be applied once) for varistor voltage change within ±10% of the initial value.	Satisfy the specification						
<b>Rated Wattage</b>	Maximum power (50 to 60Hz/AC power to be applied for 1000 hours at 125°C) for varistor voltage change within ±10% of the initial value.	Satisfy the specification						
<b>Maximum Clamping Voltage</b>	Maximum voltage across varistor when 8/20µs rated current surge is applied.	Satisfy the specification						
<b>Capacitance</b>	Varistor's capacitance at 1kHz, standard test condition.	For reference only.						
<b>Voltage Temperature Coefficient</b>	$\frac{VC \text{ at } 125^{\circ}\text{C} - VC \text{ at } 25^{\circ}\text{C}}{VC \text{ at } 25^{\circ}\text{C}} \times \frac{1}{100} \times 100 (\%/^{\circ}\text{C})$ <p style="text-align: right;">VC : Actual Varistor Voltage</p>	Within ±0.05%/°C						
<b>Maximum Applicable Voltage for a Short Period (5 minutes)</b>	Maximum DC voltage to be applied for only 5 minutes.	$\Delta V \text{ CmA} / V \text{ CmA} \leq \pm 15\%$						

## ◆ENVIRONMENTAL CHARACTERISTICS

Item	Test Conditions	Specifications
<b>High Temperature Storage (Dry heat)</b>	The specimen shall be subjected 150±2°C for 1000±12 hours without load.	$\Delta V \text{ CmA} / V \text{ CmA} \leq \pm 10\%$
<b>Low Temperature Storage</b>	The specimen shall be subjected -40±2°C for 1000±12 hours without load.	$\Delta V \text{ CmA} / V \text{ CmA} \leq \pm 5\%$
<b>Damp heat (Humidity)</b>	The specimen shall be subjected to 85±2°C, 80 to 85%RH for 1000±12 hours without load.	$\Delta V \text{ CmA} / V \text{ CmA} \leq \pm 10\%$
<b>Temperature Cycle</b>	The temperature cycle shown below shall be repeated 1000 cycles. -40±3°C, 30 minutes ⇔ +125±2°C, 30 minutes	$\Delta V \text{ CmA} / V \text{ CmA} \leq \pm 10\%$ No remarkable damage
<b>High Temperature Operating</b>	The specimen shall be subjected to 125±2°C with the maximum allowable voltage for 1000±12 hours.	$\Delta V \text{ CmA} / V \text{ CmA} \leq \pm 10\%$
<b>Damp heat Operating</b>	The specimen shall be subjected to 85±2°C, 80 to 85%RH with the maximum allowable voltage for 1000±12 hours.	$\Delta V \text{ CmA} / V \text{ CmA} \leq \pm 10\%$

Varistor voltage change of forward direction shall be measured in the test of unipolar surge life and DC load life.  
Varistor voltage change is measured after stored at Standard Test Conditions for 1 to 2 hours.



# SV Series Low varistor voltage

## ◆MECHANICAL CHARACTERISTICS

Item	Test Conditions	Specifications												
<b>Resistance to Soldering Heat</b>	<p>After V CmA is measured at room temperature, each lead shall be dipped into a solder bath at a temperature of 350±10°C to a point 2.0 to 2.5 mm from the root of the lead, and be held there for 3<sup>+1</sup><sub>0</sub> seconds, and then be stored at room temperature for 1 to 2 hours. Then, V CmA shall be examined. (Conform to JIS C 5102)</p> <p>or</p> <p>After V CmA is measured at room temperature, each lead shall be dipped into a solder bath at a temperature of 260±10°C to a point 2.0 to 2.5 mm from the root of the lead, be held there for 10±1 seconds, and then be stored at room temperature for 1 to 2 hours. Then, V CmA shall be examined. (Conform to JIS C 5102)</p>	<p>Δ V CmA/V CmA ≤ ± 5%</p> <p>No remarkable damage</p>												
<b>Solderability</b>	<p>Each lead shall be dipped into a methanol solution (about 25%) of rosin for 5 to 10 sec. Then each lead shall be dipped into a solder.</p> <table border="1"> <tr> <td>Solder</td> <td>Pb free (Sn-3.0Ag-0.5Cu)</td> <td>Eutectic (Sn/Pb)</td> </tr> <tr> <td>Solder Temp.</td> <td>245±5°C</td> <td>235±5°C</td> </tr> <tr> <td>Dipping Time</td> <td colspan="2">2±0.5sec.</td> </tr> <tr> <td>Dipping Depth</td> <td colspan="2">1.5 to 2.0mm (from the body)</td> </tr> </table>	Solder	Pb free (Sn-3.0Ag-0.5Cu)	Eutectic (Sn/Pb)	Solder Temp.	245±5°C	235±5°C	Dipping Time	2±0.5sec.		Dipping Depth	1.5 to 2.0mm (from the body)		<p>At least, 95% of the leads shall be covered with solder uniformly.</p>
Solder	Pb free (Sn-3.0Ag-0.5Cu)	Eutectic (Sn/Pb)												
Solder Temp.	245±5°C	235±5°C												
Dipping Time	2±0.5sec.													
Dipping Depth	1.5 to 2.0mm (from the body)													
<b>Lead Pull Strength</b>	<p>After gradually applying the load keeping the unit fixed for 10±5 seconds in axial direction.</p> <table border="1"> <tr> <td>Type</td> <td>Lead Diameter</td> <td>Force</td> </tr> <tr> <td>5SV,7SV</td> <td>0.6mm</td> <td>10N</td> </tr> <tr> <td>10SV,14SV,20SV</td> <td>0.8mm</td> <td>10N</td> </tr> </table>	Type	Lead Diameter	Force	5SV,7SV	0.6mm	10N	10SV,14SV,20SV	0.8mm	10N	<p>No abnormality such as disconnection.</p> <p>Δ V CmA/V CmA ≤ ± 5%</p>			
Type	Lead Diameter	Force												
5SV,7SV	0.6mm	10N												
10SV,14SV,20SV	0.8mm	10N												
<b>Lead Bend Strength</b>	<p>The unit shall be secured with its terminal kept vertical and the weight specified below be applied in the axial direction.</p> <p>The terminal shall gradually be bend by 90° in one direction then 90° in the opposite direction, and again back to original position. The damage of the terminal shall be visually examined.</p> <table border="1"> <tr> <td>Type</td> <td>Lead Diameter</td> <td>Force</td> </tr> <tr> <td>5SV,7SV</td> <td>0.6mm</td> <td>5N</td> </tr> <tr> <td>10SV,14SV,20SV</td> <td>0.8mm</td> <td>5N</td> </tr> </table>	Type	Lead Diameter	Force	5SV,7SV	0.6mm	5N	10SV,14SV,20SV	0.8mm	5N	<p>No remarkable damage as remarkable the inner ceramic element or terminal open.</p>			
Type	Lead Diameter	Force												
5SV,7SV	0.6mm	5N												
10SV,14SV,20SV	0.8mm	5N												
<b>Vibration</b>	<p>Mount varistor body on vibrator, and conduct the following vibration test.</p> <p>Peak-to-Peak amplitude : 1.5mm , Acceleration : 5G</p> <p>Vibration frequency range : 10 to 500Hz</p> <p>Sweeping time: Approximately 20 minutes for 10Hz→500Hz→10Hz</p> <p>Direction and duration of vibration : Three directions of X, Y, and Z. 2 hours each. 6 hours total.</p>	<p>No remarkable appearance abnormality.</p> <p>Δ V CmA/V CmA ≤ ± 5%</p>												
<b>Flammability test</b>	<p>The varistor shall be subjected 60 sec. applications of test flame.</p> <p>Burnar : Bunsen gas burner 9000kcal / m<sup>3</sup></p> <p>Diameter of flame nozzle : φ9.5mm</p> <p>Position : The specimen shall be fixed horizontal.</p> <p>Point of application shall be approximately center of the specimen</p>	<p>No catching fire, and no flaming drops.</p>												



- Always read "Notes on Use" before using the product in order to enable you to use the product correctly and prevent any faults and accidents from occurring.
- Request the Product Specification on the product of NIPPON CHEMI-CON CORPORATION to refer to it as well as this brochure prior to the order of the products. Some specific notes on use of the ordered product may be described in the specifications.
- The products listed in this catalog are designed and manufactured for general electronics equipment use and are not intended for use in applications that can adversely affect human life; where the malfunction of equipment may cause damage to life or property. In addition, our products are not intended to be used in specific applications that may cause a major social impact. Please consult with us in advance of usage of our products in the following listed applications. ① Aerospace equipment ② Power generation equipment such as thermal power, nuclear power etc. ③ Medical equipment ④ Transport equipment (automobiles, trains, ships, etc.) ⑤ Transportation control equipment ⑥ Disaster prevention / crime prevention equipment ⑦ Highly publicized information processing equipment ⑧ Submarine equipment ⑨ Other applications that are not considered general-purpose applications.
- The circuits described as examples in this catalog and the "delivery specifications" are featured in order to show the operations and usage of our products, however, this fact does not guarantee that the circuits are available to function in your equipment systems. We are not in any case responsible for any failures or damage caused by the use of information contained herein. You should examine our products, of which the characteristics are described in the "delivery specifications" and other documents, and determine whether or not our products suit your requirements according to the specifications of your equipment systems. Therefore, you bear final responsibility regarding the use of our products.  
Please make sure that you take appropriate safety measures such as use of redundant design and malfunction prevention measures in order to prevent fatal accidents and/or fires in the event any of our products malfunction.
- We strongly recommend our customers to purchase Nippon Chemi-Con products only through our official sales channels. We assume no responsibility for any defects or damages caused by using products purchased from outside our official sales channel or of counterfeit goods. In addition, we will ask the customer to pay the investigation cost for products purchased outside our official sales channel.
- We reserve the right to discontinue production and delivery of products. We do not guarantee that all the products included in this catalog will be available in the future.  
The aforementioned does not apply in the case of individual agreements deviating from the foregoing for customer-specific products
- We continually strive to improve the quality and reliability of our products, but in any case that our product does not meet our published specifications, please stop using it promptly and contact us immediately. As for compensation for non-conforming goods delivered by Chemi-Con, we will limit it only to goods found in non-compliance of our published specifications. This may be accomplished by a no cost replacement of non-conforming individual products, a credit of the piece price paid per each individual non-conforming product, or in other ways deemed necessary.  
In addition, we have an established system with enhanced traceability, therefore we will limit the applicable lot items for any potential compensation.

[Lead Forming Specifications](#)

[Precautions and Guidelines](#)

[Taping](#)

[Technical Terms on Varistors](#)

[Packaging • Minimum Order Quantity](#)

[Safety Standard](#)

[Technical Notes](#)