

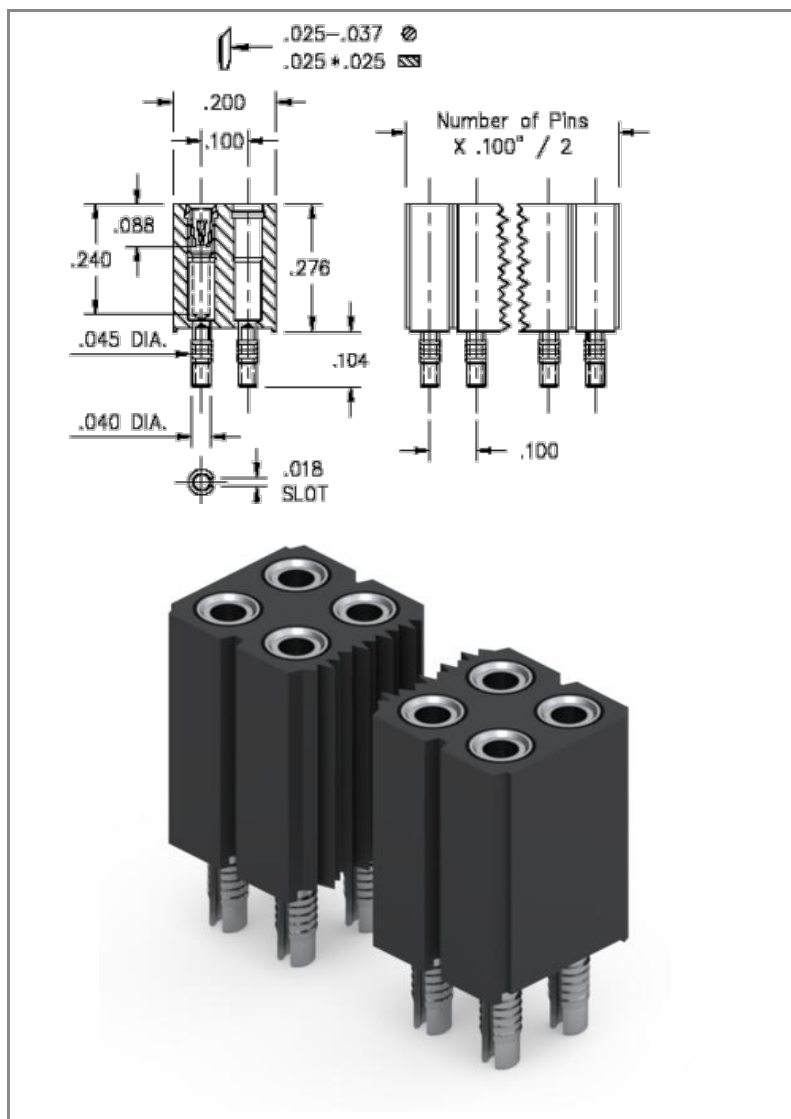

PRODUCT NUMBER: 803-99-100-61-001000

www.mill-max.com
DATA SHEET



| General Info | |
|---------------------------------|--|
| Description¹: | Compliant Tail Press Fit Socket Accepts .025"-.037" (0,635-0,940mm) dia leads |
| Type: | Interconnect |
| Category: | Machined Pin Socket |
| Mounting Style: | Press-Fit Into a Plated Through Hole |
| Tail Type: | Compliant Tail |
| # Pins: | 100 |
| Packaging²: | Packaged in Box or Tube |
| Rows: | Double Row |
| ECCN: | Contact Factory |
| HTSUS: | 8536.90.4040 |
| Product Lifecycle: | Active |
| Country Of Origin: | USA |

803-99-100-61-001000- SPECIFICATIONS

| Environmental Specs | |
|-----------------------------------|------------------|
| Temperature Range ³ : | -55/+125° C |
| Moisture Sensitivity Level (MSL): | 1 (Unlimited) |
| REACH Status: | REACH Unaffected |

| Mechanical Specs | |
|------------------|-----------------|
| Mounting Hole: | .036" (0,914mm) |

| Materials | |
|------------------------------------|--|
| Loose Pin/Receptacle # (Material): | 4614 (Brass Alloy) |
| Shell Plating: | 200 μ" Tin/Lead(93/7) over 100 μ" Nickel |
| Inner Contact #: | 47 |
| # Contact Fingers: | 6 |
| Inner Contact Material: | Beryllium Copper |
| Inner Contact Plating: | 100 μ" Tin/Lead(93/7) over 50 μ" Nickel |
| Insulator Material: | High Temp Thermoplastic |

| Technical Specs | |
|-----------------|-----------------|
| Pitch: | .100" (2,540mm) |

| Electrical Specs | |
|----------------------------------|------------------|
| Rated Voltage: | 100 VRMS/150 VDC |
| Insulation Resistance: | 10,000 MΩ min. |
| Dielectric Withstanding Voltage: | 1,000 VRMS min. |

NOTES:

- Standard Tolerances:
 Assembly tolerance: +/- .010" (.25mm)
 Insulator length: +/- .005 (.13mm)
 Insulator width: +/- .005 (.13mm)
 Insulator height: +/- .005 (.13mm)
 Pin Length: +/- .005 (.13mm)
 Pin Diameter: +/- .002 (.051mm)
 Pin Angle: +/- 2°
 Co-planarity of SMT connectors: .005" (.13mm) up to 1" (25.4mm) in connector length
 Insulator Flatness: .005" (.13mm) up to 1" (25.4mm) in connector length
- Not all part numbers in the series may be packaged in tubes. Some specific part numbers may be packaged in a box.
- Per IEC 60512-11-(4,-9,-10,-12)

ADDITIONAL NOTES AND SPECIFICATIONS

In the interest of improved design, quality and performance , Mill-Max reserves the right to make changes in its specifications without prior notice. Specifications and tolerances are provided wherever possible. The tolerance on dimensions of critical to function features is typically held tighter than the stated standard tolerances, such as press-fits, holes and lengths affecting the coplanarity of SMT products. Due to the wide variety of interconnects Mill-Max offers, the specific tolerances vary from product to product. If you need information regarding the tolerance of a particular part, please contact Technical Services.

RELATED LINKS AND DOCUMENTS

- Engineering Notebook: [Introduction to Machined Pin PCB Connectors & Interconnects](#)
- Environmental Compliance: <https://www.mill-max.com/rohs>