

© - TE Connectivity. All Rights Reserved.

REVISIONS					
P	LTR	DESCRIPTION	DATE	DWN	APVD
	U2	ECR-26-272188	27FEB2026	ABS	PS

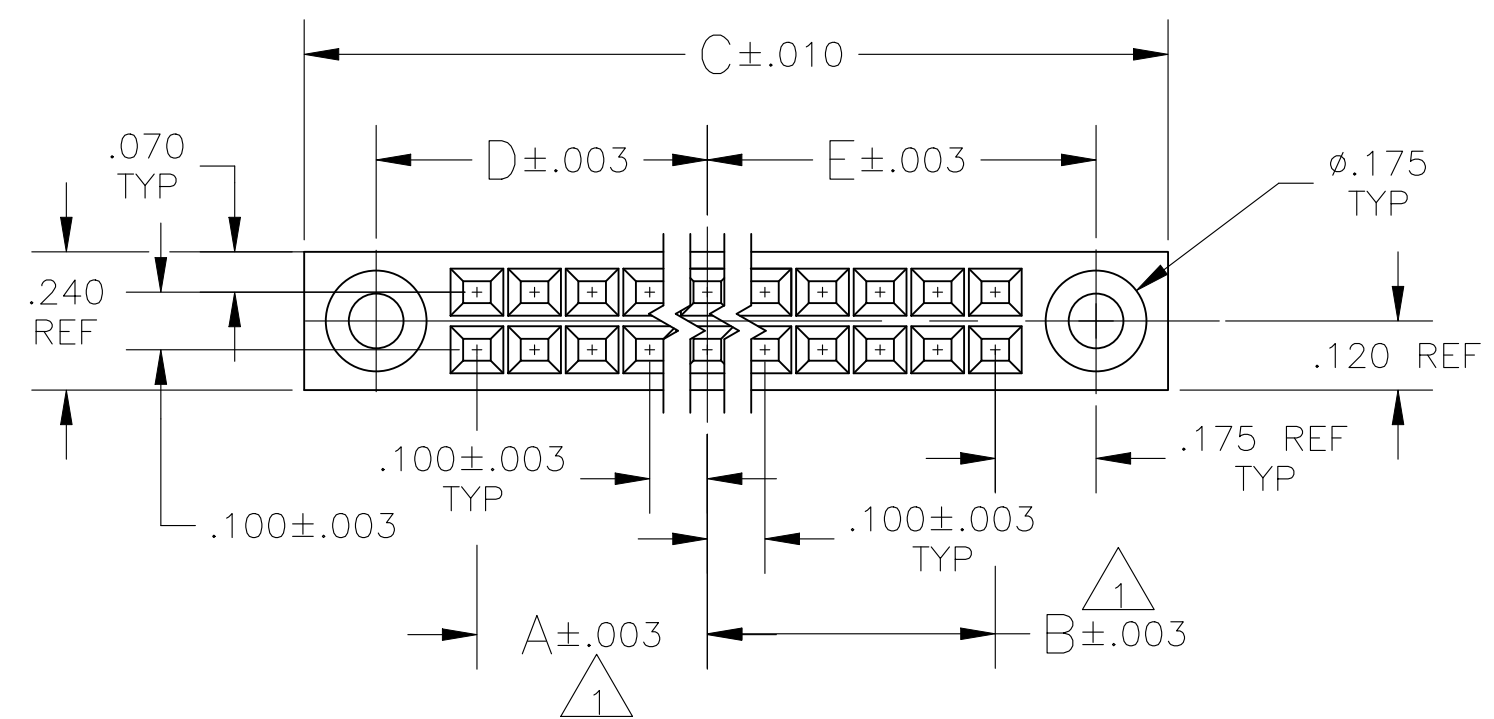

- 1 CAVITY LOCATION DIMENSIONS INCREASE IN INCREMENTS OF .100 TOLERANCE, NONCUMULATIVE.
- 2 USE EXTRACTION TOOL 91052-1 TO REMOVE RECEPTACLE CONTACTS.
- 3 SUPERSEDED BY 1-86264-0.

MARK FIRST AND EVERY FIFTH CAVITY, EITHER SIDE

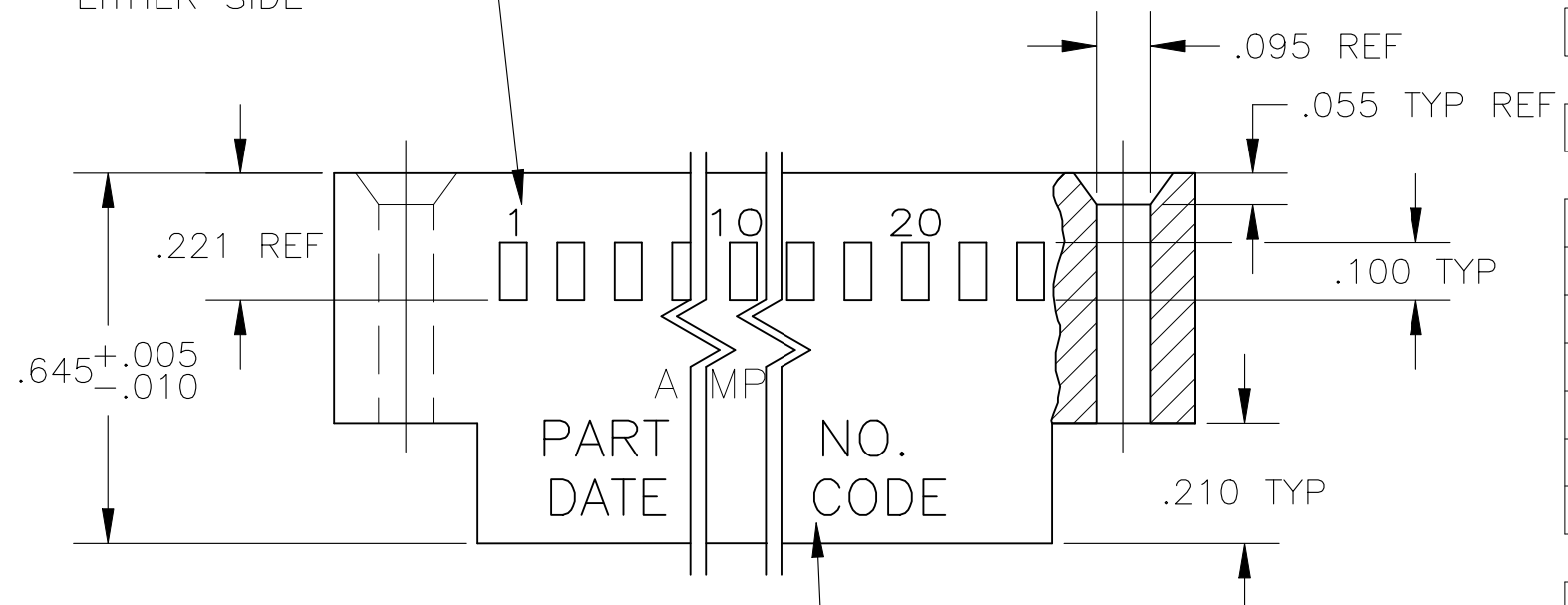

'MARK AMP', PART NO. AND DATE CODE LOCATED APPROXIMATE CENTER OF HOUSING, EITHER SIDE. PER 115-9009, AS SHOWN

OBSOLETE	.275	.375	.900	.100	.200	8	2-86256-6
	.375	.375	1.000	.200	.200	10	2-86256-5
OBSOLETE	.375	.475	1.100	.200	.300	12	2-86256-4
	.475	.575	1.300	.300	.400	16	2-86256-2
OBSOLETE	.575	.575	1.400	.400	.400	18	2-86256-1
OBSOLETE	.575	.675	1.500	.400	.500	20	2-86256-0
OBSOLETE	.675	.675	1.600	.500	.500	22	1-86256-9
OBSOLETE	.775	.775	1.800	.600	.600	26	1-86256-7
OBSOLETE	.875	.975	2.100	.700	.800	32	1-86256-4
OBSOLETE	.975	.975	2.200	.800	.800	34	1-86256-3
OBSOLETE	1.075	1.075	2.400	.900	.900	38	1-86256-1
	1.075	1.175	2.500	.900	1.000	40	1-86256-0
OBSOLETE	1.175	1.275	2.700	1.000	1.100	44	86256-8
OBSOLETE	1.375	1.475	3.100	1.200	1.300	52	86256-4

E	D	C	B	A	POS	PART NUMBER
---	---	---	---	---	-----	-------------

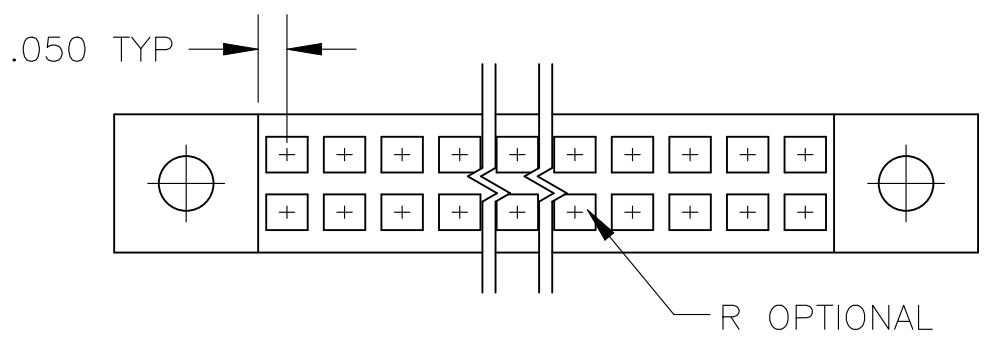

THIS DRAWING IS A CONTROLLED DOCUMENT.

DWN	BOB BOLES BG	29AUG89
CHK	J. GESFORD	12SEP89
APVD	J. GESFORD	12SEP89
PRODUCT SPEC	NAME	
APPLICATION SPEC	SIZE	
WEIGHT	CAGE CODE	DRAWING NO
MATERIAL	FINISH	RESTRICTED TO
NYLON : GLASS FILLED	-	A3 U C-86256
COLOR - BLACK		CUSTOMER DRAWING

SCALE 3:1 SHEET 1 OF 1 REV U2



CONNECTOR, MOD IV, CRIMP SNAP-IN, DOUBLE ROW, .100 CENTERS