



TAOGLAS®



Datasheet

Taoglas SMA(F)ST Adapter Series

Part No:
SMAFST.MINIUHFM.TG
SMAFST.QMAM.TG
SMAFST.TNCM.TG
SMAFST.TS9M.TG

Description:

High-performance Stainless Steel SMA(F) Adaptors

- SMA(F)ST to Mini UHF(M)ST Adapter
- SMA(F)ST to QMA(M)ST Adapter
- SMA(F)ST to TNC(M)ST Adapter
- SMA(F)ST to TS9(M)ST Adapter

Features:

Durable Stainless Steel

Reliable performance up to 8GHz

Mini UHF(M)ST Dimensions: $\varnothing 12 \times 26$ mm

QMA(M)ST Dimensions: $\varnothing 9.6 \times 21$ mm

TNC(M)ST Dimensions: $\varnothing 14.5 \times 22.9$ mm

TS9(M)ST Dimensions: $\varnothing 8 \times 14.2$ mm

RoHS & Reach Compliant

1.	Introduction	3
2.	Specifications	4
3.	Mechanical Drawing	5
4.	Packaging	6
<hr/>		
	Changelog	7

Taoglas makes no warranties based on the accuracy or completeness of the contents of this document and reserves the right to make changes to specifications and product descriptions at any time without notice. Taoglas reserves all rights to this document and the information contained herein.

Reproduction, use or disclosure to third parties without express permission is strictly prohibited.

Copyright © Taoglas Ltd.

Ireland & USA
ISO 9001:2015
Certified



Taiwan
ISO 9001:2015
Certified



1. Introduction



The Taoglas SMA(F)ST Adapter Series is a range of high-quality RF adapters designed to provide reliable interconnection between SMA female straight interfaces and commonly used RF connector types, including Mini-UHF male, QMA male, TNC male, and TS9 male. Manufactured from durable brass with nickel plating, these adapters offer robust mechanical performance and stable electrical characteristics across a wide frequency range up to 8GHz. With compact form factors, the SMA(F)ST adapter series is well suited for test equipment, RF modules, antennas, and system integration applications where dependable signal integrity and mechanical reliability are required.

SMA(F)ST Adapter SKU's and Configurations:

- **SMAFST.MINIUHFM.TG** SMA(F)ST to Mini UHF(M)ST Adapter
- **SMAFST.QMAM.TG** SMA(F)ST to QMA(M)ST Adapter
- **SMAFST.TNCM.TG** SMA(F)ST to TNC(M)ST Adapter
- **SMAFST.TS9M.TG** SMA(F)ST to TS9(M)ST Adapter

For further information please contact your regional Taoglas customer support team.

2. Specifications

Electrical	
Impedance	50Ω
VSWR	1.3 Max. @ 500 MHz – 3000 MHz 1.5 Max. @ 4000 MHz – 8000 MHz
Mechanical	
Dimensions	Ø12 x 26 mm Ø9.6 x 21 mm Ø14.5 x 22.9 mm Ø8 x 14.2 mm
Material	Brass with Nickel Plating

3. Mechanical Drawing (Units: mm)

SMAFST.MINIUHFM.TG

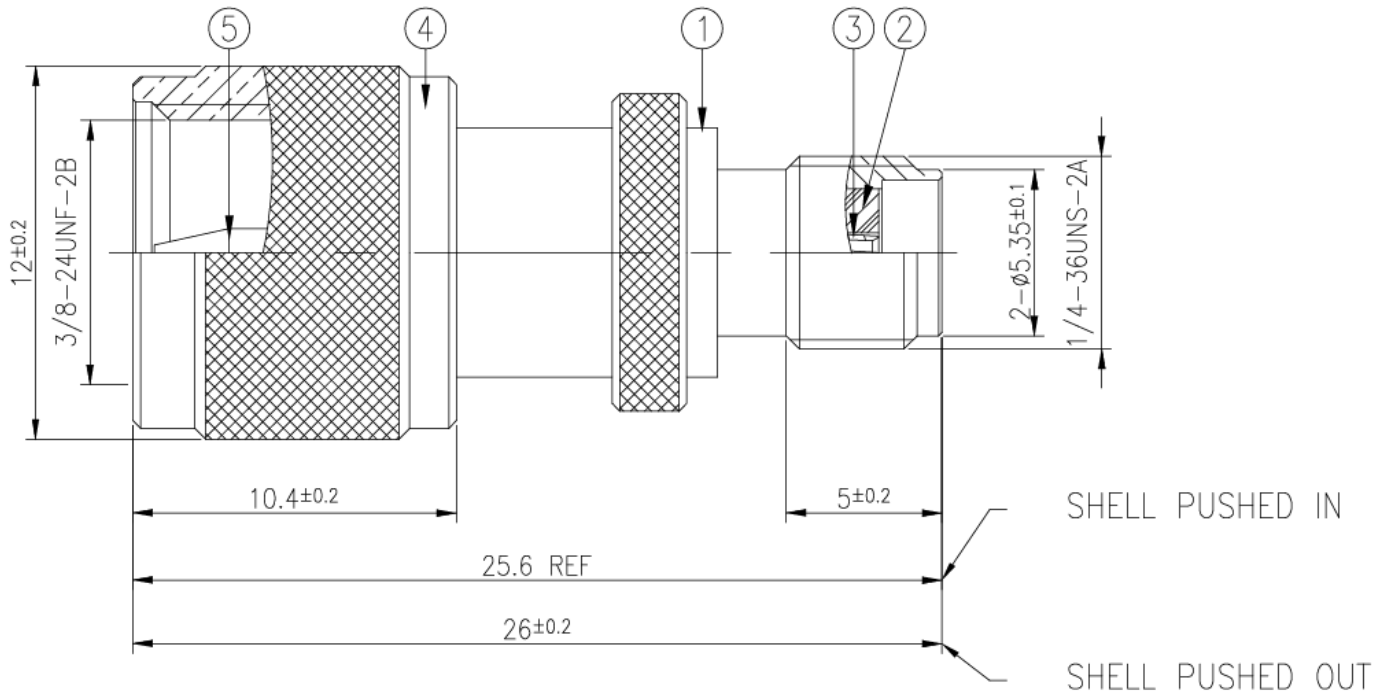

	Name	Material	Finish	QTY
1	SMA(F)ST Body	Brass	Ni Plated	1
2	SMA(F)ST Insulator	PTFE	Natural	1
3	SMA(F)ST Pin	Brass	Au Plated	1
4	Mini UHF(W)ST Body	Brass	Ni Plated	1
5	Mini UHF(W)ST Pin	Brass	Au Plated	1

SMAFST.QMAM.TG

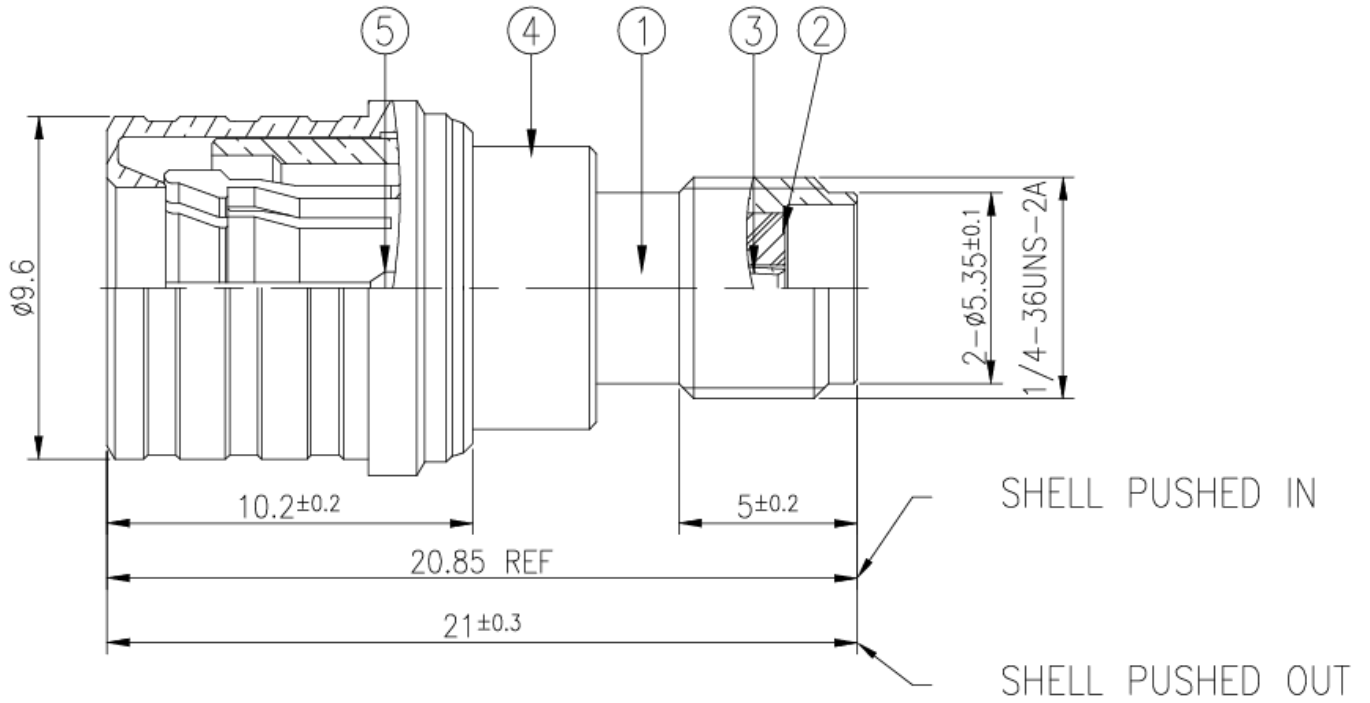

	Name	Material	Finish	QTY
1	SMA(F)ST Body	Brass	Ni Plated	1
2	SMA(F)ST Insulator	PTFE	Natural	1
3	SMA(F)ST Pin	Brass	Au Plated	1
4	QMA(M)ST Body	Brass	Ni Plated	1
5	QMA(M)ST Pin	Brass	Au Plated	1

SMAFST.TNCM.TG

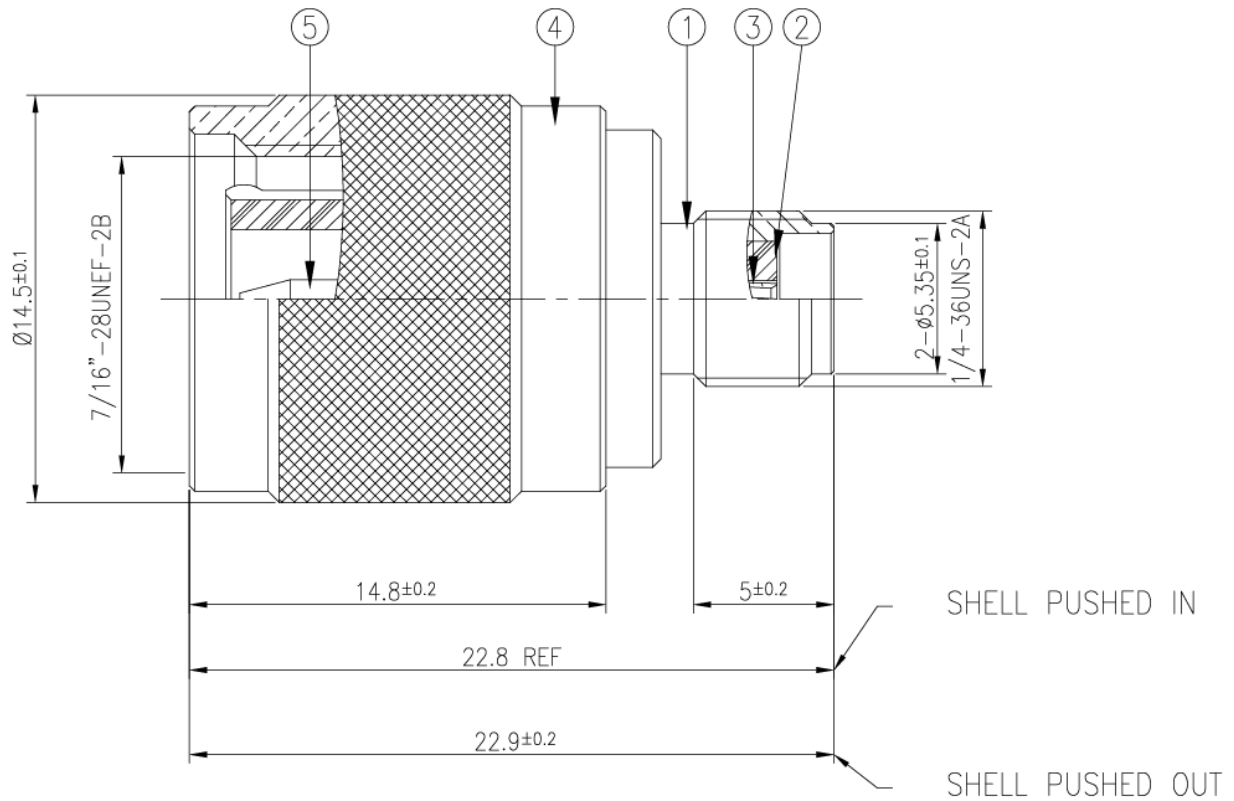

	Name	Material	Finish	QTY
1	SMAFST Body	Brass	Ni Plated	1
2	SMAFST Insulator	PTFE	Natural	1
3	SMAFST Pin	Brass	Au Plated	1
4	TNC(M)ST Body	Brass	Ni Plated	1
5	TNC(M)ST Pin	Brass	Au Plated	1

SMAFST.TS9M.TG

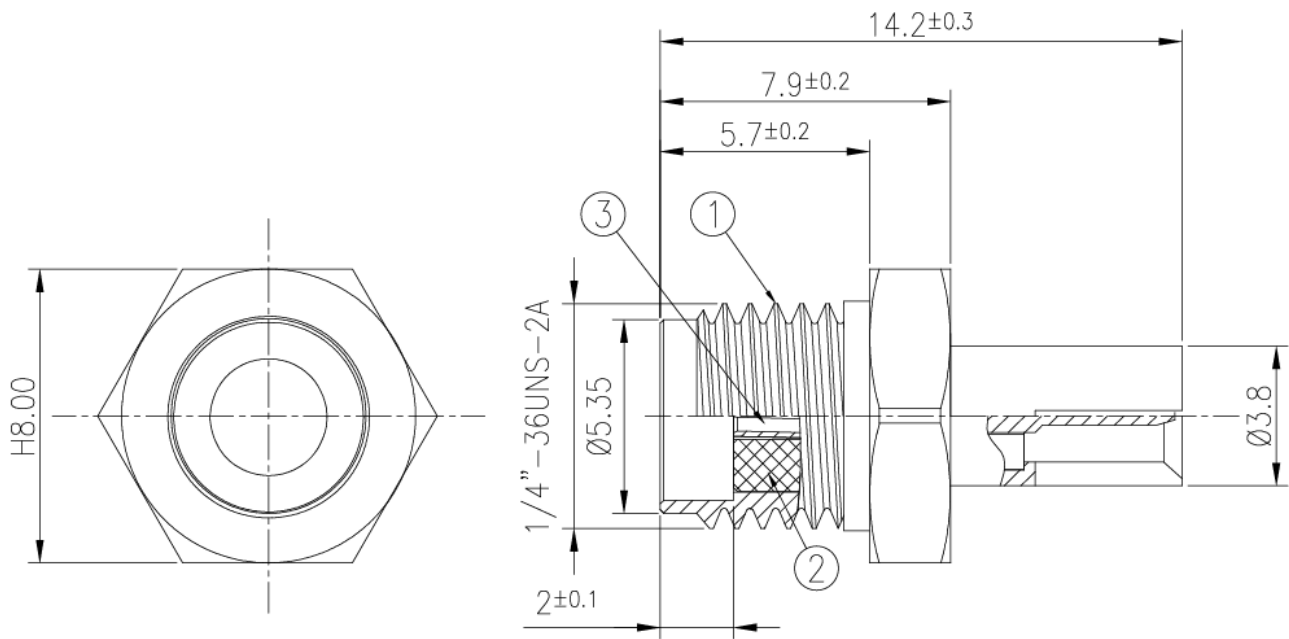

	Name	Material	Finish	QTY
1	Thread	Brass	Ni Plated	1
2	Dielectric	PTFE	White	1
3	Pin	Copper Alloy	Au Plated	1

4. Packaging

SMAFST.MINIUHFM.TG

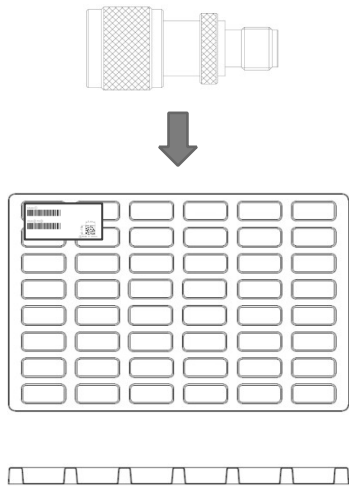

- ✓ 48 PCS / Tray
- ✓ Tray (mm): 290 x 200 x 15
- ✓ Weight (Kg): 0.42 ±3%
- ✓ SPQ Label

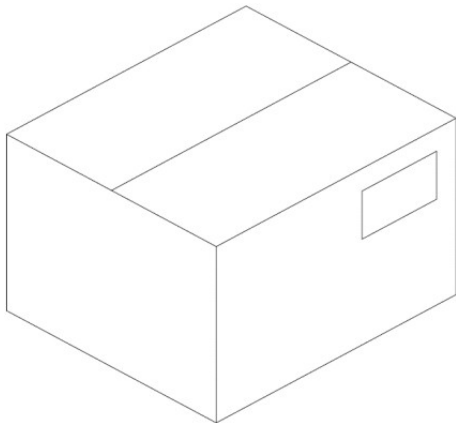

- ✓ 576 PCS / Carton
- ✓ Carton (mm): 320 x 280 x 220
- ✓ Weight (Kg): 6.5 ±3%
- ✓ Carton Label

SMAFST.QMAM.TG

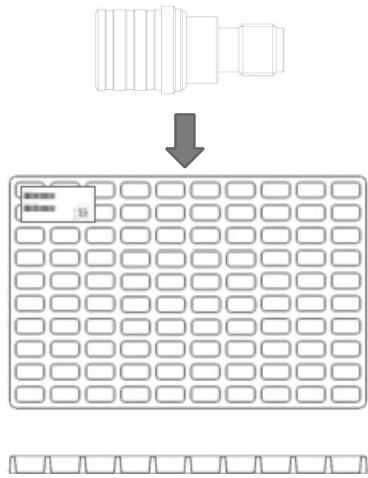

- ☑ 80 PCS / Tray
- ☑ Tray (mm): 280 x 200 x 12
- ☑ Weight (g): 0.42 ±3%
- ☑ SPQ Label

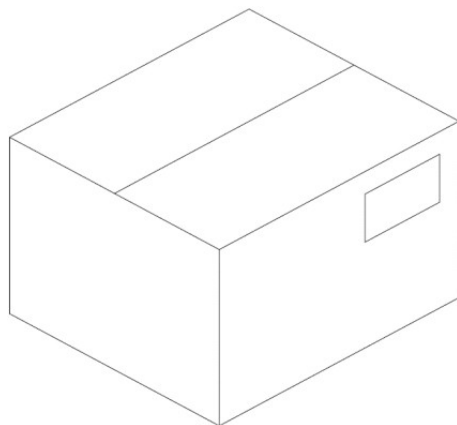

- ☑ 1440 PCS / Carton
- ☑ Carton (mm): 320 x 280 x 220
- ☑ Weight (kg): 8.7 ±3%
- ☑ Carton Label

SMAFST.TNCM.TG

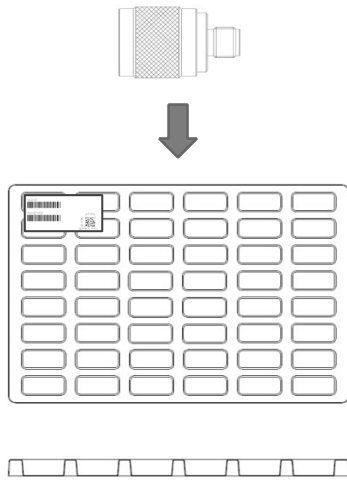

- ✓ 48 PCS / Tray
- ✓ Tray (mm): 290x200x15
- ✓ Weight (Kg): 0.65 ±3%
- ✓ SPQ Label

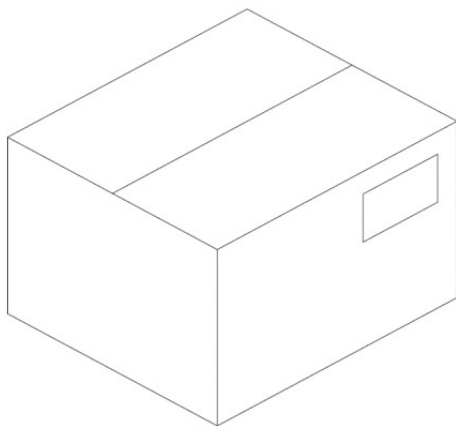

- ✓ 576 PCS / Carton
- ✓ Carton (mm): 320 x 280 x 220
- ✓ Weight (Kg): 9.4 ±3%
- ✓ Carton Label

SMAFST.TNCM.TG

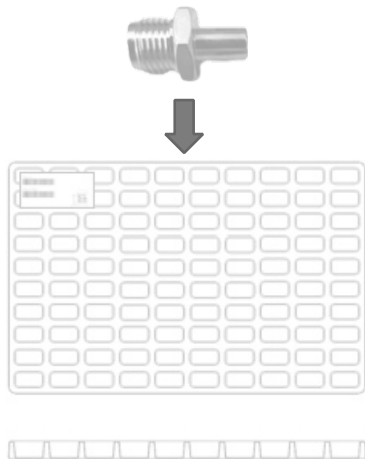

- ☑ 120 PCS / Tray
- ☑ Tray (mm): 280x210x13
- ☑ Weight (g): 0.22 ±3%
- ☑ SPQ Label

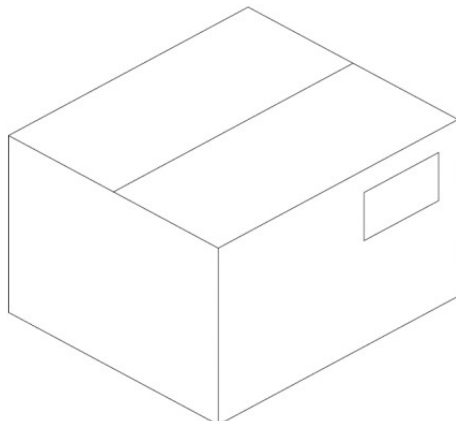

- ☑ 3000 PCS / Carton
- ☑ Carton (mm): 320x280x220
- ☑ Weight (kg): 7 ±3%
- ☑ Carton Label

Changelog for the datasheet

SPE-26-8-051 – SMAFST Adapter Series

Revision: A (Original First Release)

Date:	2026-18-03
Notes:	Initial release
Author:	Conor McGrath

Previous Revisions



TAOGLAS®

www.taoglas.com

