

Data Sheet | Item Number: 243-144

PUSH WIRE® splicing connector; for solid conductors; max. 0.5 mm Ø; 4-conductor; transparent housing; light gray cover; Surrounding air temperature: max 60°C; transparent

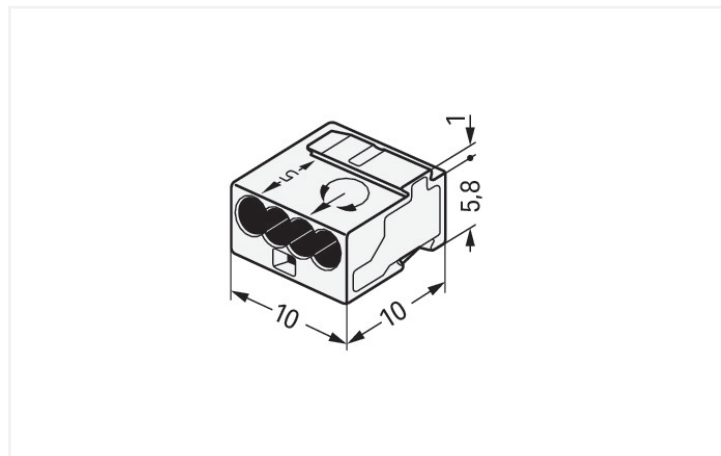

<https://www.wago.com/243-144>

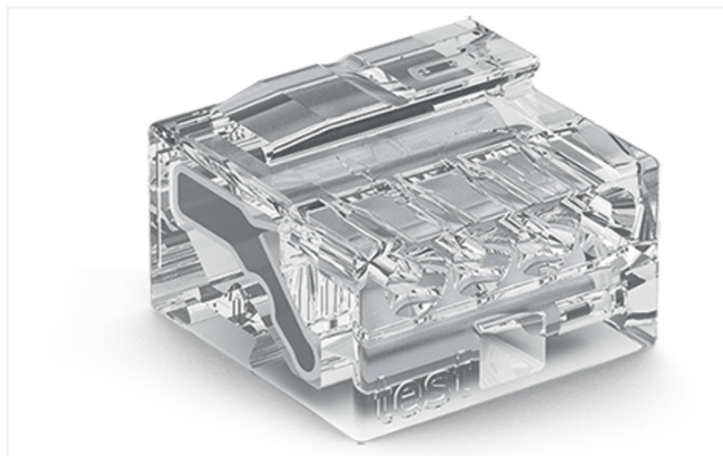

Color: transparent

Dimensions in mm

Push wire® splicing connector, 243 Series, transparent

Push wire® splicing connector (item number 243-144) simplifies electrical installations. WAGO's 243 Series MICRO PUSH WIRE® connectors for junction boxes are suitable for low-voltage building installations. Whether for bell or intercom system wiring, our MICRO junction box connectors are just right thanks to their compact design—perfect for these types of installations. Strip lengths must be between 5 and 6 mm when connecting conductors to push wire® splicing connector. This splicing connector has a rated voltage of 100 V and can handle currents up to 6 A. This product incorporates one conductor terminal and utilizes PUSH WIRE®. Our reliable PUSH WIRE® connection offers the fastest method for clamping conductors. It utilizes the conductor's stiffness to overcome the clamping spring's contact force. The item's dimensions are (10 x 6.8 x 10) mm (width x height x depth).

Notes

General safety information

NOTICE: Observe installation and safety instructions!

- **Only to be used by electricians!**
- Do not work under voltage/load!
- Use only for proper use!
- Observe national regulations/standards/guidelines!
- Observe technical specifications for the products!
- Observe the number of permissible potentials!
- Do not use damaged/dirty components!
- Observe conductor types, cross-sections and strip lengths!
- Insert conductor until it hits the product's backstop!
- Use original accessories!

To be sold only with installation instructions!

Electrical data

Ratings per	EN 60664		
Overvoltage category	III	III	II
Pollution degree	3	2	2
Nominal voltage	-	-	100 V
Rated impulse withstand voltage	-	-	1.5 kV
Rated current	-	-	6 A

General information

Wiring direction: Side-entry wiring

Connection Data

Clamping units	4
Total number of potentials	1
Number of connection types	1
Number of levels	1

Connection 1

Connection technology	PUSH WIRE®
Actuation type	Push-in
Connectable conductor materials	Copper
Solid conductor	26 ... 24 AWG
Conductor diameter	0.4 ... 0.5 mm / 26 ... 24 AWG
Strip length	5 ... 6 mm / 0.2 ... 0.24 inches
Wiring direction	Side-entry wiring

Physical data

Width	10 mm / 0.394 inches
Height	6.8 mm / 0.268 inches
Depth	10 mm / 0.394 inches

Material data

Note (material data)	Information on material specifications can be found here
Color	transparent
Cover color	light gray
Material group	IIIa
Insulation material (main housing)	Polycarbonate (PC)
Flammability class per UL94	V2
Fire load	0.013 MJ
Weight	0.9 g

Environmental requirements

Ambient temperature (operation)	+60 °C
Continuous operating temperature	105 °C

Commercial data

PU (SPU)	1000 (100) pcs
Packaging type	Box
Country of origin	DE
GTIN	4044918937788
Customs tariff number	85369010000

Product Classification

UNSPSC	39121409
eCl@ss 10.0	27-14-11-04
eCl@ss 9.0	27-14-11-04
ETIM 9.0	EC000446
ETIM 10.0	EC000446
ECCN	NO US CLASSIFICATION

Environmental Product Compliance

RoHS Compliance Status	Compliant, No Exemption
------------------------	-------------------------

Approvals / Certificates

General approvals



Approval	Standard	Certificate Name
CCA DEKRA Certification B.V.	EN 60998	NTR NL 7812
CSA DEKRA Certification B.V.	C22.2	70048857
KEMA/KEUR DEKRA Certification B.V.	EN 60998	71-112493

Approvals for marine applications



Approval	Standard	Certificate Name
LR Lloyds Register	EN 60998	LR22207029TA

Downloads

Environmental Product Compliance

Compliance Search
Environmental Product Compliance 243-144

Documentation

Bid Text			
243-144	19.02.2019	xml 3.08 KB	
243-144	17.05.2017	doc 25.00 KB	
ausschreiben.de 243-144			

CAD/CAE-Data

CAD data
2D/3D Models 243-144

CAE data
EPLAN Data Portal 243-144
WSCAD Universe 243-144
ZUKEN Portal 243-144

1 Compatible Products

1.1 Optional Accessories

1.1.1 Mounting adapter

1.1.1.1 Mounting accessories



Item No.: 243-112

Mounting carrier; for 4 connectors; 243 Series; for DIN-35 rail mounting/screw mounting; orange

Item No.: 243-113

Mounting carrier; for 6 connectors; 243 Series; for DIN-35 rail mounting/screw mounting; orange

Installation Notes

Conductor termination

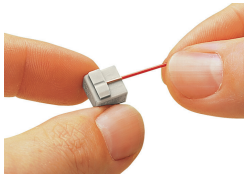

Strip solid conductors to 5 ... 6 mm (0.19 ... 0.23 inch).

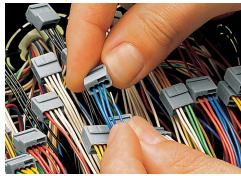

Termination: Insert the stripped solid conductor until it hits the backstop.

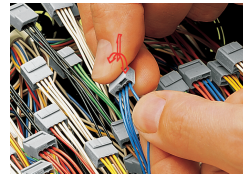

Removal: Hold conductor to be removed and twist alternately left and right while pulling the connector.

Installation



Connector strips:

Assembling modular connectors into connector strips.

Commoning



Commoned connector strips

Testing

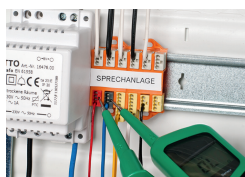

Testing via test port opposite to conductor entry.



The 243 Series can be used in both communication and alarm systems according to the VdS (German Association of Property Insurers) guidelines.

No general approval is given to PUSH WIRE® connectors by the VdS association. The connectors must be tested together with the different parts of the system.

The requirements for connectors are specified in the VdS guidelines for junction boxes (VdS 2116) in section 8.7: "The junction box connectors must be designed to guarantee a reliable and stable connection."

The verification of the fulfillment of these requirements is documented in the VDE test report No. 2574-1440-4031 for the insulated 243 Series PUSH WIRE® Connectors.