

1/2.8-inch 2 MP CMOS Digital Image Sensor with Global Shutter AR0235CS

Description

The AR0235CS is a 1/2.8-inch CMOS digital image sensor with an active-pixel array of 1920 (H) x 1200 (V). It incorporates a new innovative global shutter pixel design optimized for accurate and fast capture of moving scenes. The sensor produces clear, low noise images in both low-light and bright scenes. It includes sophisticated camera functions such as auto exposure control, windowing, row skip mode, column-skip mode, pixel-binning and both video and single frame modes. It is programmable through a simple two-wire serial interface. The AR0235CS produces extraordinarily clear, sharp digital pictures, and its ability to capture both continuous video and single frames makes it the perfect choice for a wide range of applications, including scanning and industrial inspection.

Table 1. KEY PERFORMANCE PARAMETERS

Parameter	Typical Value
Optical Format	1/2.8-inch (6.34 mm)
Active Pixels	1920 (H) x 1200 (V) not including 8 border pixels on each side
Pixel Size	2.8 μm
Color Filter Array	RGB Bayer, Monochrome
Chief Ray Angle	0 or 28°
Shutter Type	Global Shutter
Input Clock Range	10–48 MHz
Output Interface	8-bit/10-bit MIPI 1, 2, or 4-lane
Output Data Rate	Maximum Serial Output Data Rate 850 Mbps/lane
Frame Rate Full Resolution	120 fps (10-bit)
Responsivity	41.9 ke-/lux*s (Monochrome) TBD (RGB)
SNR _{MAX}	37 dB
Dynamic Range	65.3 dB
Supply Voltage	
I/O	1.8 V
Digital	1.25 V
Analog	2.8 V
Power Consumption	252 mW, at 120 fps, Full Resolution
Operating Temperature	(–30 °C < T _J < +85 °C)
Optimal Performance Temperature Range	(0 °C < T _J < +60 °C)
Package Options	7.66 x 5.64 mm 62-ball CSP θ_{JA} : 32 °C/W (Note 1) θ_{JB} : 11 °C/W
	Bare Die

1. θ_{JA} is dependent on the customer module design and should not be used for calculating junction temperature.

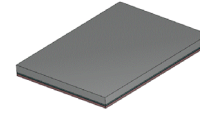

ODCSP62
CASE 570CY

ORDERING INFORMATION

See detailed ordering and shipping information on page 2 of this data sheet.

Public Data Sheet

Interested in what you see? If you would like more detailed information, please request the full version of our data sheet.

[Request Full Data Sheet](#)

Features

- Superior Low-light and IR Performance
- 8-bit/10-bit MIPI, 1/2/4-lane MIPI
- Automatic Black Level Calibration (ABLC)
- Horizontal and Vertical Mirroring, Windowing and Pixel Binning
- 5 x 5 Statistics Engine for On-chip Auto Exposure Control for Any Programmable Region of Interest (ROI)
- Flexible Control for Row and Column Skip Mode
- On-chip Trigger Mode for Synchronization
- Built in Flash Control
- Two On Chip Phase Lock Loop (PLL)
- Context Switching
- 1056 Bytes One-time Programmable Memory (OTPM)
- Simple Two-wire Fast-mode + Serial Interface

Applications

- Bar Code Scanner
- Factory Automation
- Autonomous Mobile Robot (AMR)
- Machine Vision
- 3D Scanning
- Biometrics

AR0235CS

ORDERING INFORMATION

Table 2. AVAILABLE PART NUMBERS

Part Number	Product Description	Product Attribute Description
AR0235CSSM00SMKA0-CP	Mono, 0° CRA	CSP with Protective Film
AR0235CSSM00SMKA0-CP2	Mono, 0° CRA	CSP with Protective Film, MOQ 50 Pieces
AR0235CSSM00SMKA0-CR	Mono, 0° CRA	CSP without Protective Film
AR0235CSSM00SMKAH3-GEVB	Mono, 0° CRA	Demo Board

AR0235CSSM28SMKA0-CP	Mono, 28° CRA	CSP with Protective Film
AR0235CSSM28SMKA0-CP2	Mono, 28° CRA	CSP Chip Tray with Protective Film, MOQ 50 Pieces
AR0235CSSM28SMKA0-CR	Mono, 28° CRA	CSP without Protective Film
AR0235CSSM28SMKAH3-GEVB	Mono, 28° CRA	Demo Board
PRISM1M-AR0235CSSM130110-GEVB	Mono, 28° CRA	Premier Reference Image Sensor Module (PRISM)

AR0235CSSC00SMKA0-CP	RGB, 0° CRA	CSP, with Protective Film
AR0235CSSC00SMKA0-CP2	RGB, 0° CRA	CSP, with Protective Film, MOQ 50
AR0235CSSC00SMKA0-CR	RGB, 0° CRA	CSP, without Protective Film
AR0235CSSC00SMKAH3-GEVB	RGB, 0° CRA	Demo Board

AR0235CSSC28SMKA0-CP	RGB, 28° CRA	CSP, with Protective Film
AR0235CSSC28SMKA0-CP2	RGB, 28° CRA	CSP, with Protective Film, MOQ 50
AR0235CSSC28SMKA0-CR	RGB, 28° CRA	CSP, without Protective Film
AR0235CSSC28SMKAH3-GEVB	RGB, 28° CRA	Demo Board
PRISM1M-AR0235CSSC130110-GEVB	RGB, 28° CRA	Premier Reference Image Sensor Module (PRISM)

NOTE: Refer to AR0235 Die Data Sheet for Die Part Numbers and Ordering Information.

Table 3. FRAME RATE OF DIFFERENT MODES OF OPERATION

Resolution	Mode	Frame Rate (frames per sec)
Full Resolution 1920 x 1200	Master	120
	Slave Integration Start	90
	Slave Integration Time	90
	Slave Integration Start and Readout Start	90
	Slave Integration Start and Integration	depends on exp (not constant frame rate)
2x2 Subsampling 960 x 600	Master	245
	Slave Integration Start	160
	Slave Integration Time	160
	Slave Integration Start and Readout Start	160
	Slave Integration Start and Integration	depends on exp (not constant frame rate)

AR0235CS

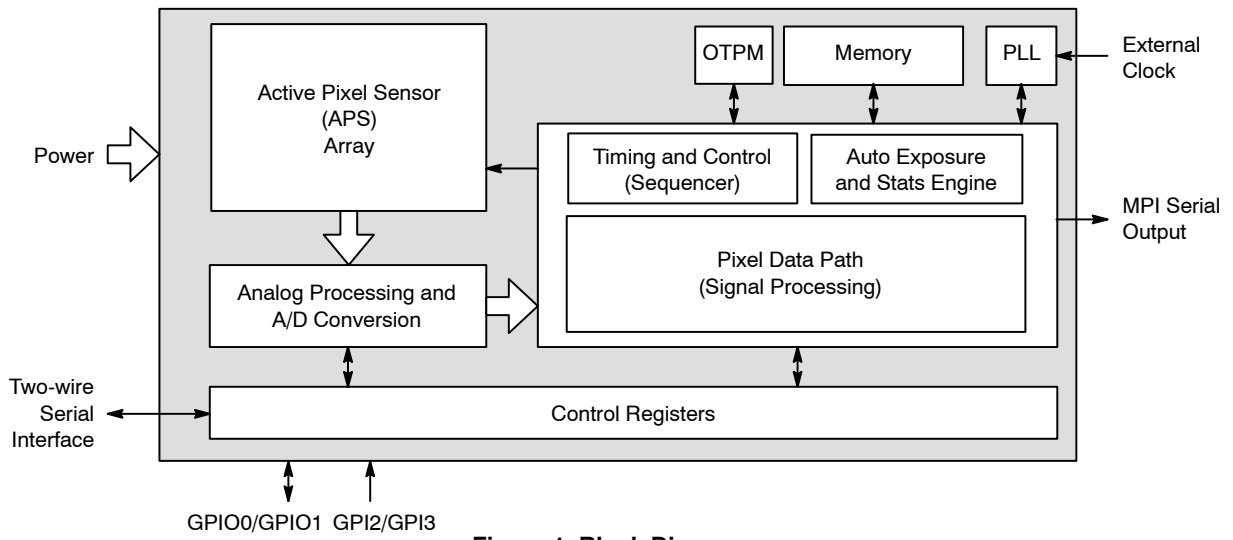
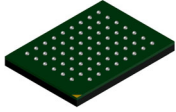
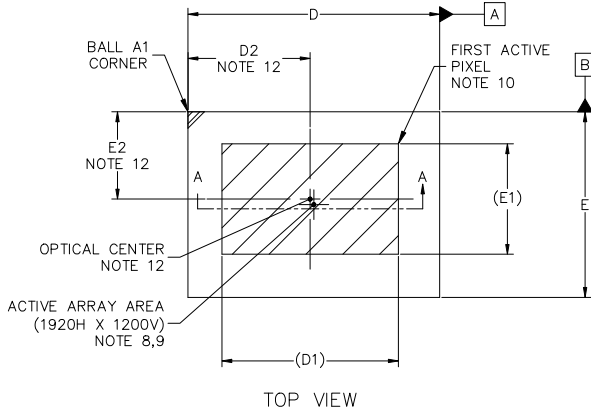

Figure 1. Block Diagram



ODCSP62 7.66x5.65x0.62, 0.70P
CASE 570CY
ISSUE B

DATE 09 DEC 2024



NOTES:

1. DIMENSIONING AND TOLERANCING PER ASME Y14.5M, 2018.
2. CONTROLLING DIMENSION: MILLIMETERS [mm].
3. SOLDER BALL DIAMETER IS MEASURED AT THE MAXIMUM SOLDER BALL DIAMETER PARALLEL TO DATUM C.
4. COPLANARITY APPLIES TO THE SPHERICAL CROWNS OF THE SOLDER BALLS.
5. DATUM C, THE SEATING PLANE IS DEFINED BY THE SPHERICAL CROWNS OF THE SOLDER BALLS.
6. GLASS: 0.400 THICKNESS; REFRACTIVE INDEX = 1.52.
7. AIR GAP BETWEEN GLASS AND PIXEL ARRAY: 0.045 THICKNESS.
8. PARALLELISM APPLIES ONLY TO THE ACTIVE ARRAY.
9. MAXIMUM ROTATION OF ACTIVE ARRAY RELATIVE TO DATUMS A AND B IS ±0.1°.
10. REFER TO THE DEVICE DATA SHEET FOR TOTAL PIXEL ARRAY DEFINITIONS.
11. PACKAGE CENTER(X, Y) = (0.000, 0.000).
12. OPTICAL CENTER RELATIVE TO PACKAGE CENTER (X, Y) = (-0.114, 0.170).

DIM	MILLIMETERS		
	MIN.	NOM.	MAX
A	----	----	0.821
A1	0.085	0.128	0.171
A2	0.430	0.445	0.460
A3	0.138	0.180	0.222
b	0.220	0.250	0.280
D	7.642	7.667	7.692
D1	5.376 REF.		
D2	3.692	3.717	3.742
E	5.626	5.651	5.676
E1	3.360 REF.		
E2	2.631	2.656	2.681
e	0.700 BSC		

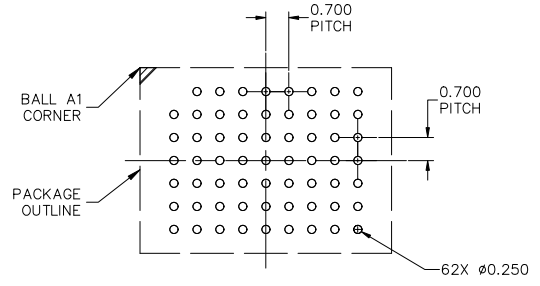
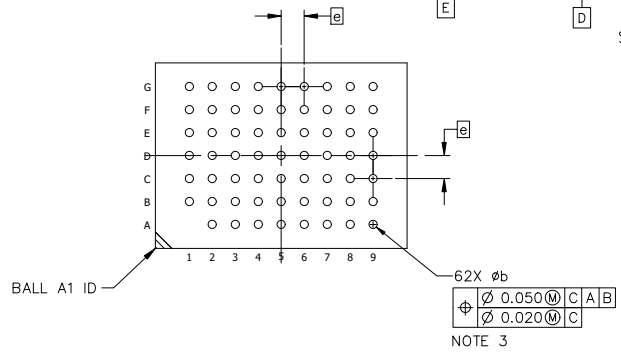
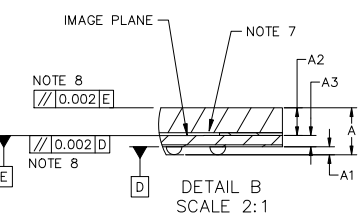
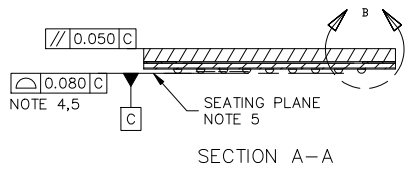

GENERIC MARKING DIAGRAM*

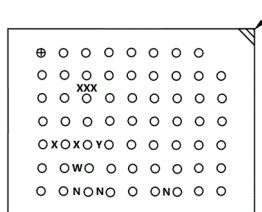

XXX = Specific Device Code
Y = Year Code
W = Work Week Code
NNN = Serial Number

*This information is generic. Please refer to device data sheet for actual part marking. Pb-Free indicator, "G" or microdot "•", may or may not be present. Some products may not follow the Generic Marking.

DOCUMENT NUMBER:	98AON25223H	Electronic versions are uncontrolled except when accessed directly from the Document Repository. Printed versions are uncontrolled except when stamped "CONTROLLED COPY" in red.
DESCRIPTION:	ODCSP62 7.66x5.65x0.62, 0.70P	PAGE 1 OF 1

onsemi and ONSEMI are trademarks of Semiconductor Components Industries, LLC dba onsemi or its subsidiaries in the United States and/or other countries. onsemi reserves the right to make changes without further notice to any products herein. onsemi makes no warranty, representation or guarantee regarding the suitability of its products for any particular purpose, nor does onsemi assume any liability arising out of the application or use of any product or circuit, and specifically disclaims any and all liability, including without limitation special, consequential or incidental damages. onsemi does not convey any license under its patent rights nor the rights of others.

onsemi, **Onsemi**, and other names, marks, and brands are registered and/or common law trademarks of Semiconductor Components Industries, LLC dba "**onsemi**" or its affiliates and/or subsidiaries in the United States and/or other countries. **onsemi** owns the rights to a number of patents, trademarks, copyrights, trade secrets, and other intellectual property. A listing of **onsemi**'s product/patent coverage may be accessed at www.onsemi.com/site/pdf/Patent-Marking.pdf. **onsemi** reserves the right to make changes at any time to any products or information herein, without notice. The information herein is provided "as-is" and **onsemi** makes no warranty, representation or guarantee regarding the accuracy of the information, product features, availability, functionality, or suitability of its products for any particular purpose, nor does **onsemi** assume any liability arising out of the application or use of any product or circuit, and specifically disclaims any and all liability, including without limitation special, consequential or incidental damages. Buyer is responsible for its products and applications using **onsemi** products, including compliance with all laws, regulations and safety requirements or standards, regardless of any support or applications information provided by **onsemi**. "Typical" parameters which may be provided in **onsemi** data sheets and/or specifications can and do vary in different applications and actual performance may vary over time. All operating parameters, including "Typicals" must be validated for each customer application by customer's technical experts. **onsemi** does not convey any license under any of its intellectual property rights nor the rights of others. **onsemi** products are not designed, intended, or authorized for use as a critical component in life support systems or any FDA Class 3 medical devices or medical devices with a same or similar classification in a foreign jurisdiction or any devices intended for implantation in the human body. Should Buyer purchase or use **onsemi** products for any such unintended or unauthorized application, Buyer shall indemnify and hold **onsemi** and its officers, employees, subsidiaries, affiliates, and distributors harmless against all claims, costs, damages, and expenses, and reasonable attorney fees arising out of, directly or indirectly, any claim of personal injury or death associated with such unintended or unauthorized use, even if such claim alleges that **onsemi** was negligent regarding the design or manufacture of the part. **onsemi** is an Equal Opportunity/Affirmative Action Employer. This literature is subject to all applicable copyright laws and is not for resale in any manner.

ADDITIONAL INFORMATION

TECHNICAL PUBLICATIONS:

Technical Library: www.onsemi.com/design/resources/technical-documentation
onsemi Website: www.onsemi.com

ONLINE SUPPORT: www.onsemi.com/support

For additional information, please contact your local Sales Representative at www.onsemi.com/support/sales

