

# HCPL-M452/HCPL-M453

## Small Outline, 5-Lead, High-Speed Optocouplers

### Description

The Broadcom<sup>®</sup> HCPL-M452/HCPL-M453 small outline high CMR, high-speed, diode-transistor optocouplers are single-channel devices in a five-lead miniature footprint.

The SO-5 JEDEC registered (MO-155) package outline does not require *through holes* in a PCB. This package occupies approximately one-fourth the footprint area of the standard dual-inline package. The lead profile is designed to be compatible with standard surface-mount processes.

These diode-transistor optocouplers use an insulating layer between the LED and an integrated photon detector to provide electrical insulation between input and output. Separate connections for the photodiode bias and output transistor collector increase the speed up to a hundred times over that of a conventional phototransistor coupler by reducing the base-collector capacitance.

The HCPL-M452 is designed for high-speed TTL/TTL applications. A standard 16-mA TTL sink current through the input LED provides enough output current for 1 TTL load and a 5.6 k $\Omega$  pull-up resistor. CTR of the HCPL-M452 is 19% minimum at  $I_F = 16$  mA.

The HCPL-M453 is an HCPL-M452 with increased common mode transient immunity of 15,000 V/ $\mu$ s minimum at  $V_{CM} = 1500$ V guaranteed.

### Features

- Surface mountable
- Very small, low-profile JEDEC registered package outline
- Compatible with infrared vapor phase reflow and wave soldering processes
- Very high common mode transient immunity: 1,5000 V/ $\mu$ s at  $V_{CM} = 1500$ V guaranteed (HCPL-M453)
- High speed: 1 Mb/s
- TTL compatible
- Open collector output
- Worldwide safety approval:
  - UL1577 recognized, 3750Vrms/1min
  - CSA approved
- Lead-free option

### Applications

- Line receivers: High common mode transient immunity (>1000 V/ $\mu$ s) and low input-output capacitance (0.6 pF).
- High-speed logic ground isolation: TTL/TTL, TTL/LTTL, TTL/CMOS, TTL/LSTTL
- Replace slow phototransistor optocouplers
- Replace pulse transformers: save board space and weight
- Analog signal ground isolation: integrated photon detector provides improved linearity over phototransistor type

**CAUTION!** The small device geometries inherent to the design of this bipolar component increase the component's susceptibility to damage from electrostatic discharge (ESD). Take normal static precautions in handling and assembly of this component to prevent damage and/or degradation which may be induced by ESD.

## Ordering Options

SO-5 Package	Standard DIP	SO-8 Package
HCPL-M452	HCPL-4502	HCPL-0452
HCPL-M453	HCPL-4503	HCPL-0453

**NOTE:** These devices equivalent to 6N135/6N136 devices but without the base lead.

## Ordering Information

HCPL-M452 and HCPL-M453 are UL Recognized with 3750 Vrms for 1 minute per UL1577.

Part Number	Option		Package	Surface Mount	Tape and Reel	Quantity
	RoHS Compliant	non-RoHS Compliant				
HCPL-M452/HCPL-M453	-000E	No option	SO-5	X		100 per tube
	-500E	#500		X	X	1500 per reel

To order, choose a part number from the part number column and combine with the desired option from the option column to form an order entry.

### Example 1:

HCPL-M452-500E to order product of SO-5 surface mount package in tape and reel packaging and RoHS compliant.

### Example 2:

HCPL-M452 to order product of SO-5 surface mount package in tube packaging and non-RoHS compliant.

Option data sheets are available. Contact your Broadcom sales representative or authorized distributor for information

**NOTE:** The notation '#XXX' is used for existing products, while (new) products launched since July 15, 2001 and RoHS compliant will use '-XXXE'.

# Outline Drawing (JEDEC MO-155)

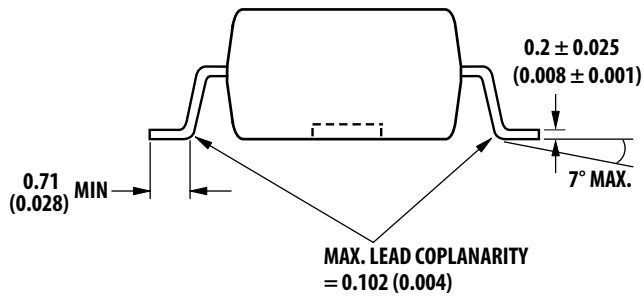
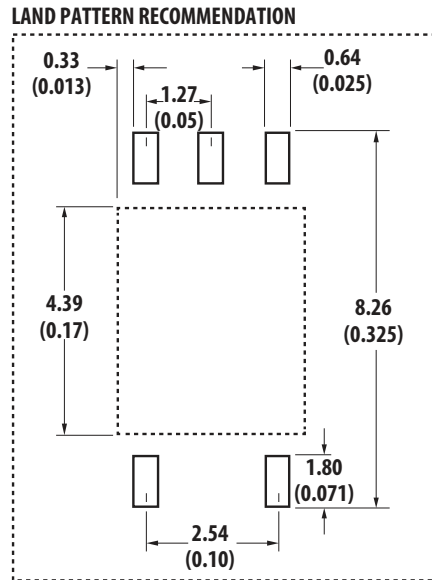
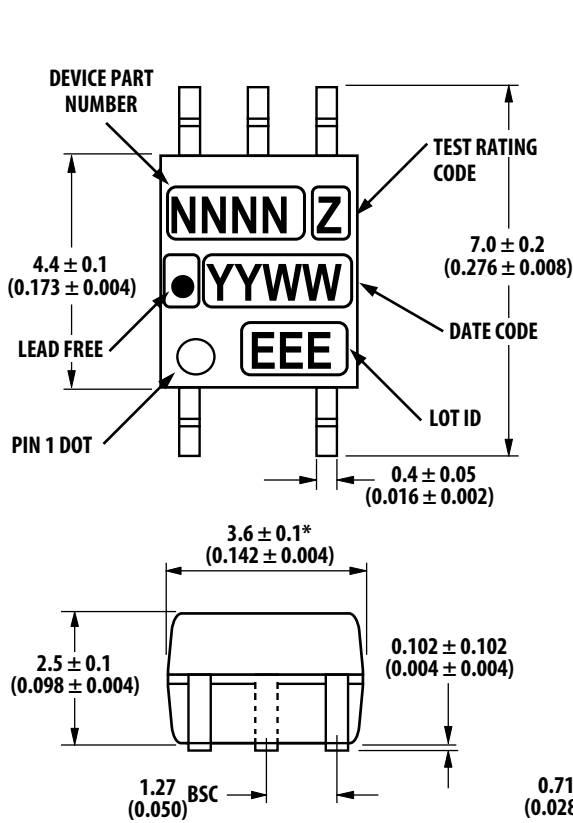

Dimensions in millimeters (inches).  
 Note: Floating Lead Protrusion is 0.15 mm (6 mils) max.  
 \* Maximum Mold flash on each side is 0.15 mm (0.006).

## Schematic

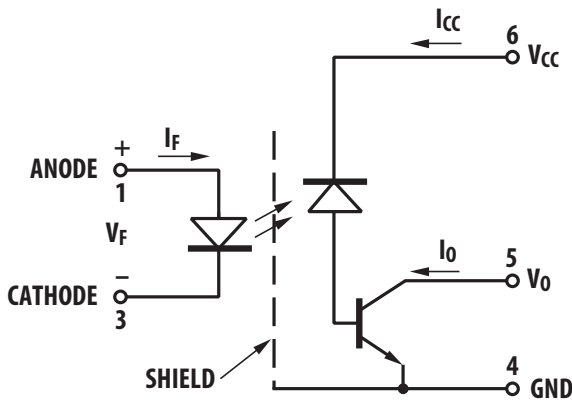

## Land Pattern Recommendation

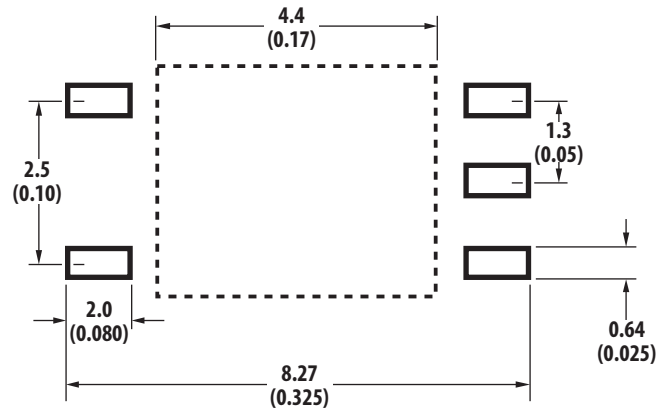

Dimensions in millimeters and (in.).

# Solder Reflow Thermal Profile

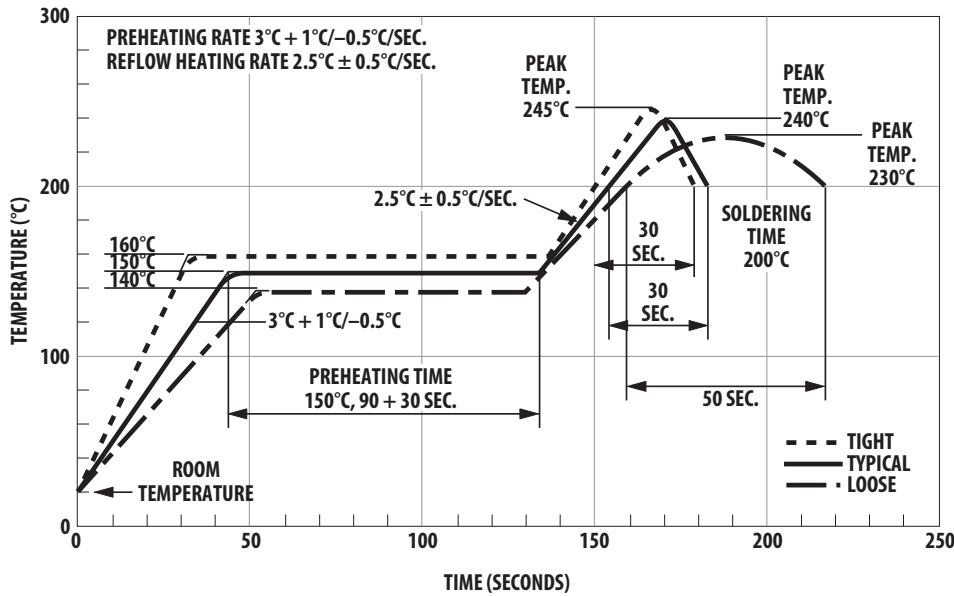

**NOTE:** Note: Non-halide flux should be used.

## Recommended Pb-Free IR Profile

The recommended reflow condition as per JEDEC Standard, J-STD-020 (latest revision).

Non-halide flux should be used.

## Regulatory Information

The HCPL-M452/M453 are approved by the following organizations:

<b>UL</b>	Approved under UL 1577, component recognition program up to $V_{ISO} = 3750 V_{RMS}$ expected prior to product release.
<b>CSA</b>	Approved under CSA Component Acceptance Notice #5.

## Insulation Related Specifications

Parameter	Symbol	Value	Units	Conditions
Min External Air Gap (Clearance)	L(IO1)	≥ 5	mm	Measured from input terminals to output terminals
Min. External Tracking Path (Creepage)	L(IO2)	≥ 5	mm	Measured from input terminals to output terminals
Min. Internal Plastic Gap (Clearance)		0.08	mm	Through insulation distance conductor to conductor
Tracking Resistance	CTI	175	V	DIN IEC 112/VDE 0303 Part 1
Isolation Group (per DIN VDE 0109)		IIIa		Material Group DIN VDE 0109

## Absolute Maximum Ratings

No derating required up to 85°C.

Storage Temperature	-55°C to +125°C
Operating Temperature	-55°C to +100°C
Average Input Current – $I_F$	25 mA <sup>a</sup>
Peak Input Current – $I_F$	50 mA <sup>b</sup> (50% duty cycle, 1 ms pulse width)
Peak Transient Input Current – $I_F$	1.0A (1 μs pulse width, 300 pps)
Reverse Input Voltage – $V_R$ (Pin3-1)	5V
Input Power Dissipation	45 mW <sup>c</sup>
Average Output Current – $I_O$ (Pin 5)	8 mA
Peak Output Current	16 mA
Output Voltage – $V_O$ (Pin 5-4)	-0.5V to 20V
Supply Voltage – $V_{CC}$ (Pin 6-4)	-0.5V to 30V
Output Power Dissipation	100 mW <sup>d</sup>
Infrared and Vapor Phase Reflow Temperature	See below

- Derate linearly above 85°C free-air temperature at a rate of 0.5 mA/°C.
- Derate linearly above 85°C free-air temperature at a rate of 1.0 mA/°C.
- Derate linearly above 85°C free-air temperature at a rate of 1.1 mW/°C.
- Derate linearly above 85°C free-air temperature at a rate of 2.3 mW/°C.

## Electrical Specifications

Over recommended temperature ( $T_A = 0^\circ\text{C}$  to  $70^\circ\text{C}$ ) unless otherwise specified.

**NOTE:** Use of a 0.1- $\mu\text{F}$  bypass capacitor connected between pins 4 and 6 is recommended.

Parameter	Symbol	Min.	Typ. <sup>a</sup>	Max.	Units	Test Conditions			Figure	Note
Current Transfer Ratio	CTR	20	24	50	%	$T_A = 25^\circ\text{C}$	$V_O = 0.4\text{V}$	$V_{CC} = 4.5\text{V}$	1, 2, 4	b
		15	25	—			$V_O = 0.5\text{V}$	$I_F = 16\text{ mA}$		
Logic Low Output Voltage	$V_{OL}$	—	0.1	0.4	V	$T_A = 25^\circ\text{C}$	$I_O = 3.0\text{ mA}$	$I_F = 16\text{ mA}$		
		—	—	0.5			$I_O = 2.4\text{ mA}$			
Logic High Output Current	$I_{OH}$	—	0.003	0.5	$\mu\text{A}$	$T_A = 25^\circ\text{C}$	$V_O = V_{CC} = 5.5\text{V}$	$I_F = 0\text{ mA}$	7	
		—	0.01	1.0			$V_O = V_{CC} = 5.5\text{V}$			
		—	—	50						
Logic Low Supply Current	$I_{CCL}$	—	50	200		$I_F = 16\text{ mA}$	$V_O = \text{Open}$	$V_{CC} = 15\text{V}$		c
Logic High Supply Current	$I_{CCH}$	—	0.02	1		$T_A = 25^\circ\text{C}$	$I_F = 0\text{ mA}$	$V_{CC} = 15\text{V}$		c
		—	0.02	2	$V_O = \text{open}$					
Input Forward Voltage	$V_F$	—	1.5	1.7	V	$T_A = 25^\circ\text{C}$	$I_F = 16\text{ mA}$		3	
		—	1.5	1.8						
Input Reverse Breakdown Current	$BV_R$	5	—	—	V	$I_R = 10\text{ }\mu\text{A}$				
Temperature Coefficient of Forward Voltage	$\Delta V_F/\Delta T_A$	—	-1.6	—	$\text{mV}/^\circ\text{C}$	$I_F = 16\text{ mA}$				
Input Capacitance	$C_{IN}$	—	60	—	$\text{pF}$	$f = 1\text{ MHz}$	$V_F = 0\text{V}$			
Input-Output Insulation Voltage	$V_{ISO}$	3750	—	—	$V_{RMS}$		$RH < 50\%$	$t = 1\text{ min}$		d, e
Resistance (Input-Output)	$R_{I-O}$	—	$10^{12}$	—	$\Omega$	$V_{I-O} = 500\text{ Vdc}$				d
Capacitance (Input-Output)	$C_{I-O}$	—	0.6	—	$\text{pF}$	$f = 1\text{ MHz}$				d

a. All typicals at  $T_A = 25^\circ\text{C}$ .

b. CURRENT TRANSFER RATIO in percent is defined as the ratio of output collector current,  $I_O$ , to the forward LED input current,  $I_F$ , times 100.

c. Use of a 0.1- $\mu\text{F}$  bypass capacitor connected between pins 4 and 6 is recommended.

d. Device considered a two-terminal device: Pins 1 and 3 shorted together and Pins 4, 5 and 6 shorted together.

e. In accordance with UL 1577, each optocoupler is proof tested by applying an insulation test voltage  $\geq 4500\text{ V}_{RMS}$  for 1 second (leakage detection current limit,  $I_{I-e} \leq 5\text{ }\mu\text{A}$ ).

# Switching Specifications

Over recommended temperature ( $T_A = 0^\circ\text{C}$  to  $70^\circ\text{C}$ )  $V_{CC} = 5\text{V}$ ,  $I_F = 16\text{ mA}$  unless otherwise specified.

Parameter	Symbol	Device	Min.	Typ. <sup>a</sup>	Max.	Units	Test Conditions		Figure	Note
Propagation Delay Time to Logic Low at Output	$t_{PHL}$	HCPL-M452	—	0.2	0.8	$\mu\text{s}$	$T_A = 25^\circ\text{C}$	$R_L = 1.9\text{k}\Omega$	5., 6, 10	b
		HCPL-M453	—	0.2	1.0					
Propagation Delay Time to Logic High at Output	$t_{PLH}$	HCPL-M452	—	0.6	0.8	$\mu\text{s}$	$T_A = 25^\circ\text{C}$	$R_L = 1.9\text{k}\Omega$	5, 6, 10	b
		HCPL-M453	—	0.6	1.0					
Common Mode Transient Immunity at Logic High Level Output	$ CM_H $	HCPL-M452	—	1	—	$\text{kV}/\mu\text{s}$	$T_A = 25^\circ\text{C}$	$V_{CM} = 10\text{ V}_{P-P}$	11	b, c
		HCPL-M453	15	30	—			$V_{CM} = 1500\text{ V}_{P-P}$		
Common Mode Transient Immunity at Logic Low Level Output	$ CM_L $	HCPL-M452	—	1	—	$\text{kV}/\mu\text{s}$	$T_A = 25^\circ\text{C}$	$V_{CM} = 10\text{ V}_{P-P}$	11	b, c
		HCPL-M433	15	30	—			$V_{CM} = 1500\text{ V}_{P-P}$		
Bandwidth	BW		—	3	—	MHz	$R_L = 100\text{ k}\Omega$ See Test Circuit		8, 9	d

- a. All typicals at  $T_A = 25^\circ\text{C}$ .
- b. The 1.9 k $\Omega$  load represents 1 TTL unit load of 1.6 mA and the 5.6 k $\Omega$  pull-up resistor.
- c. Common transient immunity in a Logic High level is the maximum tolerable (positive)  $dV_{CM}/dt$  on the rising edge of the common mode pulse,  $V_{CM}$ , to assure that the output will remain in a Logic High state (that is,  $V_O > 2.0\text{V}$ ). Common mode transient immunity in a Logic Low level is the maximum tolerable (negative)  $dV_{CM}/dt$  on the falling edge of the common mode pulse signal,  $V_{CM}$  to assure that the output will remain in a Logic Low state (that is,  $V_O < 0.8\text{V}$ ).
- d. The frequency at which the ac output voltage is 3 dB below its mid-frequency value.

Figure 1: dc and Pulsed Transfer Characteristics

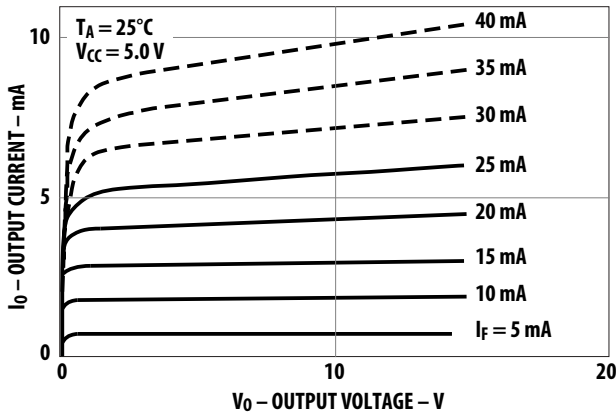

Figure 2: Current Transfer Ratio vs. Input Current

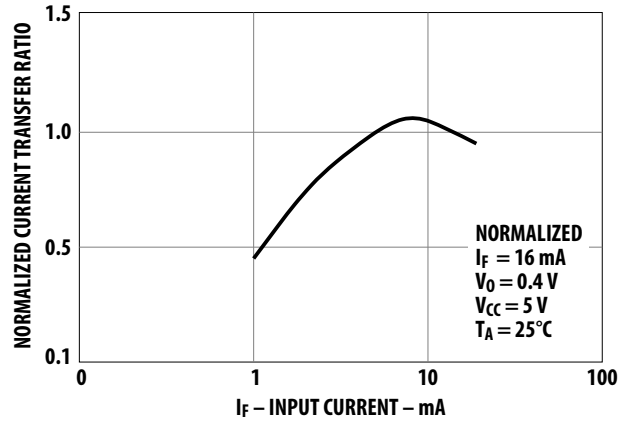

Figure 3: Input Current vs. Forward Voltage

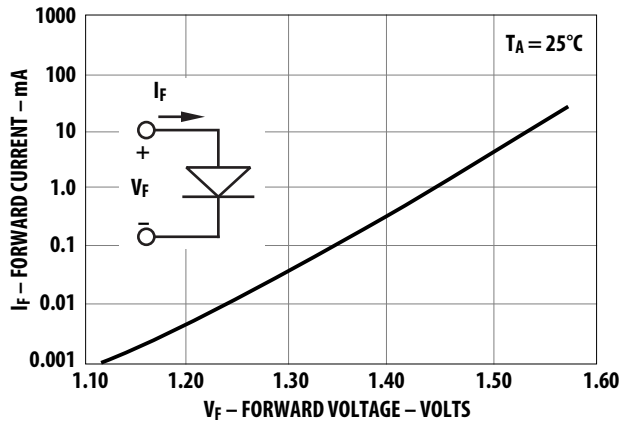

Figure 4: Current Transfer Ratio vs. Temperature

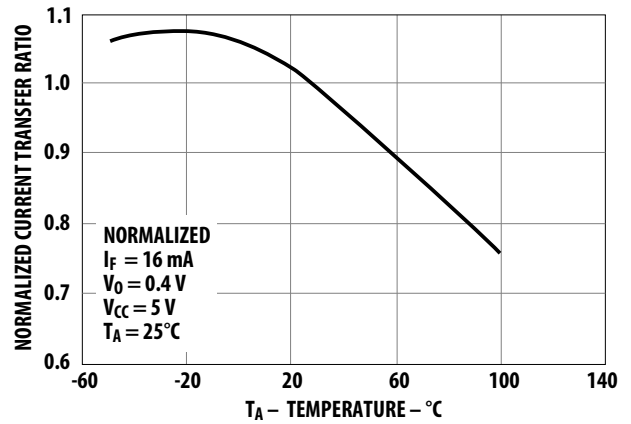

Figure 5: Propagation Delay vs. Temperature

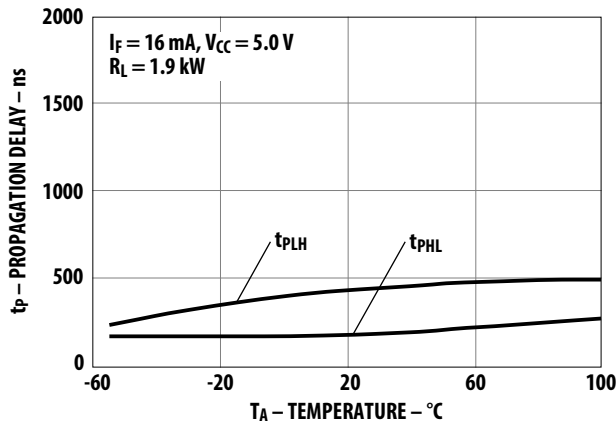

Figure 6: Propagation Delay Time vs. Load Resistance

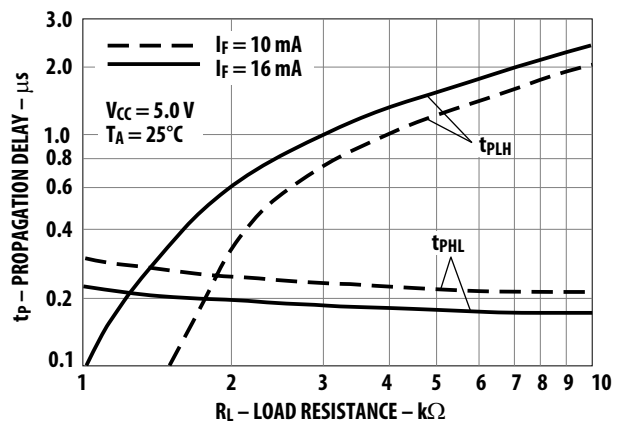

Figure 7: Logic High Output Current vs. Temperature

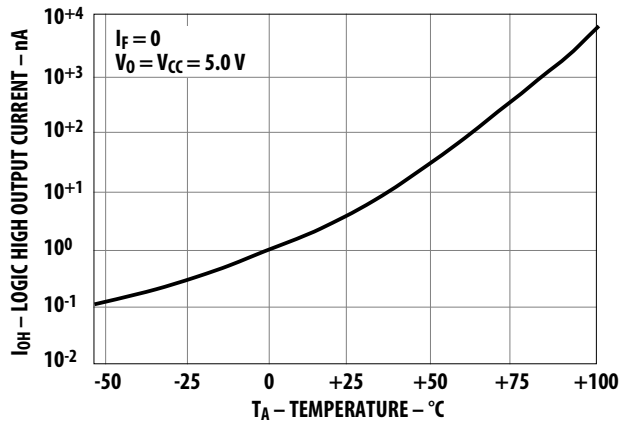

Figure 8: Small-Signal Current Transfer Ratio vs. Quiescent Input Current

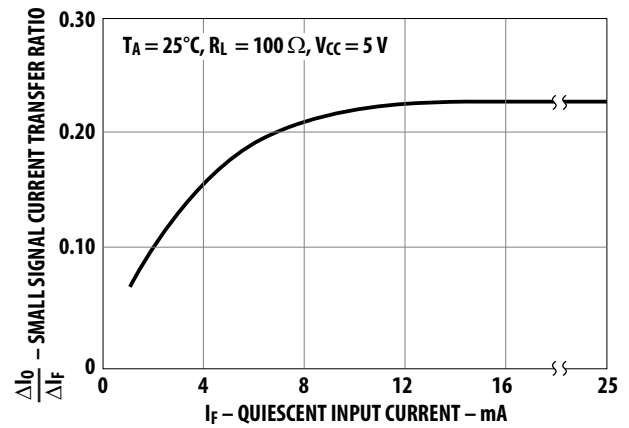

Figure 9: Frequency Response

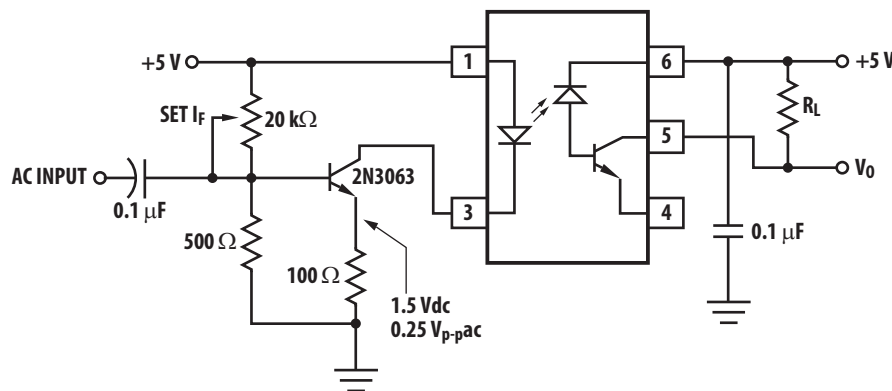
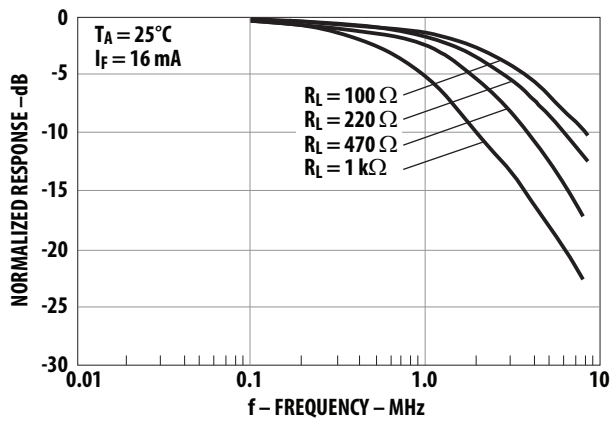

Figure 10: Switching Test Circuit

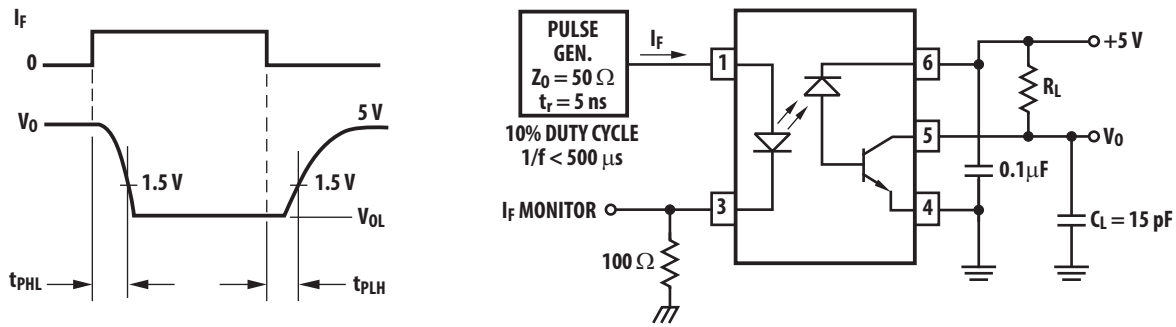
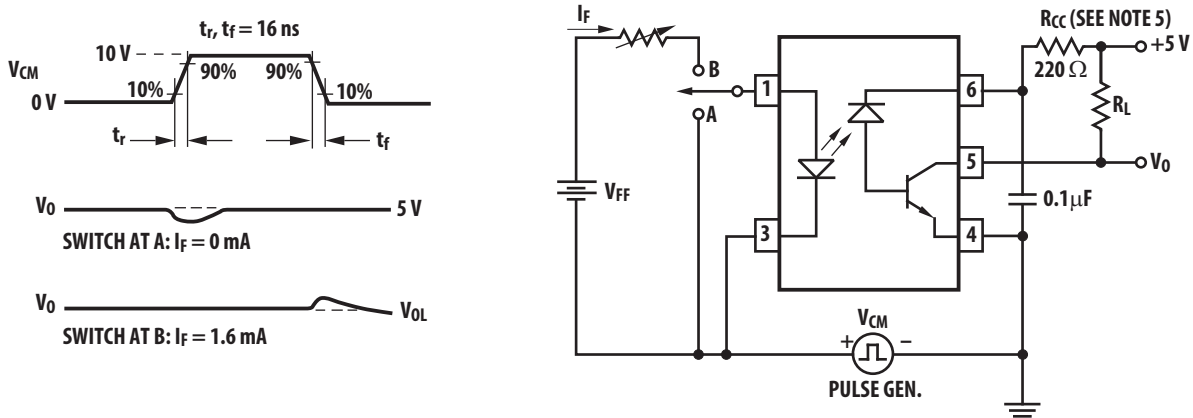

Figure 11: Test Circuit for Transient Immunity and Typical Waveforms



Copyright © 2015–2022 Broadcom. All Rights Reserved. The term “Broadcom” refers to Broadcom Inc. and/or its subsidiaries. For more information, go to [www.broadcom.com](http://www.broadcom.com). All trademarks, trade names, service marks, and logos referenced herein belong to their respective companies.

Broadcom reserves the right to make changes without further notice to any products or data herein to improve reliability, function, or design. Information furnished by Broadcom is believed to be accurate and reliable. However, Broadcom does not assume any liability arising out of the application or use of this information, nor the application or use of any product or circuit described herein, neither does it convey any license under its patent rights nor the rights of others.

