

CY8CKIT-062S2-AI PSOC™ 6 AI Evaluation Kit guide

About this document

Scope and purpose

This guide provides the information about the PSOC™ 6 AI Evaluation Kit contents. This guide also provides the information on how to use the out-of-the-box application and collect real time sensor data, data labeling from DEEPCRAFT™ Studio, and hardware details of the evaluation kit.

Intended audience

This evaluation board is intended for customers who want to create a machine learning model using sensors present in Infineon PSOC™ 6 AI Evaluation Board.

Important notice**Important notice**

“Evaluation Boards and Reference Boards” shall mean products embedded on a printed circuit board (PCB) for demonstration and/or evaluation purposes, which include, without limitation, demonstration, reference and evaluation boards, kits and design (collectively referred to as “Reference Board”).

Environmental conditions have been considered in the design of the Evaluation Boards and Reference Boards provided by Infineon Technologies. The design of the Evaluation Boards and Reference Boards has been tested by Infineon Technologies only as described in this document. The design is not qualified in terms of safety requirements, manufacturing and operation over the entire operating temperature range or lifetime.

The Evaluation Boards and Reference Boards provided by Infineon Technologies are subject to functional testing only under typical load conditions. Evaluation Boards and Reference Boards are not subject to the same procedures as regular products regarding returned material analysis (RMA), process change notification (PCN) and product discontinuation (PD).

Evaluation Boards and Reference Boards are not commercialized products, and are solely intended for evaluation and testing purposes. In particular, they shall not be used for reliability testing or production. The Evaluation Boards and Reference Boards may therefore not comply with CE or similar standards (including but not limited to the EMC Directive 2004/EC/108 and the EMC Act) and may not fulfill other requirements of the country in which they are operated by the customer. The customer shall ensure that all Evaluation Boards and Reference Boards will be handled in a way which is compliant with the relevant requirements and standards of the country in which they are operated.

The Evaluation Boards and Reference Boards as well as the information provided in this document are addressed only to qualified and skilled technical staff, for laboratory usage, and shall be used and managed according to the terms and conditions set forth in this document and in other related documentation supplied with the respective Evaluation Board or Reference Board.

It is the responsibility of the customer’s technical departments to evaluate the suitability of the Evaluation Boards and Reference Boards for the intended application, and to evaluate the completeness and correctness of the information provided in this document with respect to such application.

The customer is obliged to ensure that the use of the Evaluation Boards and Reference Boards does not cause any harm to persons or third party property.

The Evaluation Boards and Reference Boards and any information in this document is provided "as is" and Infineon Technologies disclaims any warranties, express or implied, including but not limited to warranties of non-infringement of third party rights and implied warranties of fitness for any purpose, or for merchantability.

Infineon Technologies shall not be responsible for any damages resulting from the use of the Evaluation Boards and Reference Boards and/or from any information provided in this document. The customer is obliged to defend, indemnify and hold Infineon Technologies harmless from and against any claims or damages arising out of or resulting from any use thereof.

Infineon Technologies reserves the right to modify this document and/or any information provided herein at any time without further notice.

Safety precautions**Safety precautions**

Note: Please note the following warnings regarding the hazards associated with development systems

Table 1 **Safety precautions**

Caution: The evaluation or reference board contains parts and assemblies sensitive to electrostatic discharge (ESD). Electrostatic control precautions are required when installing, testing, servicing or repairing the assembly. Component damage may result if ESD control procedures are not followed. If you are not familiar with electrostatic control procedures, refer to the applicable ESD protection handbooks and guidelines.

Table of contents

Table of contents

- About this document** 1
- Important notice** 2
- Safety precautions** 3
- Table of contents** 4
- 1 Introduction** 6
 - 1.1 Kit contents 6
 - 1.2 Getting started 8
 - 1.3 Board details 9
 - 1.4 Additional learning resources 11
 - 1.5 Technical support 11
 - 1.6 Documentation conventions 12
- 2 Kit operation** 13
 - 2.1 Theory of operation 13
 - 2.2 Using the OOB example 18
 - 2.3 Creating a project and program/debug using ModusToolbox™ software 18
- 3 Hardware** 23
 - 3.1 Schematics 23
 - 3.2 Hardware functional description 23
 - 3.2.1 Power supply system 23
 - 3.2.1.1 Power supply inputs 23
 - 3.2.1.2 Voltage regulators 26
 - 3.2.2 PSOC™ 5LP based KitProg3 programmer and debugger 28
 - 3.2.2.1 PSOC™ 5LP based KitProg3 28
 - 3.2.2.2 KitProg3 serial interface with PSOC™ 6 30
 - 3.2.2.3 KitProg3 based voltage measurement 30
 - 3.2.2.4 KitProg3 programming mode selection button and status LED 31
 - 3.2.3 PSOC™ 6 MCU features 31
 - 3.2.3.1 PSOC™ 6 MCU power supply 32
 - 3.2.3.2 PSOC™ 6 MCU IO signals 33
 - 3.2.3.3 PSOC™ 6 MCU clock sources 35
 - 3.2.3.4 PSOC™ 6 device external programming/debugging header 35
 - 3.2.3.5 PSOC™ 6 USB device 36
 - 3.2.4 User LEDs and power LED 37
 - 3.2.5 Reset and user buttons 38
 - 3.2.6 XENSIV™ digital barometric pressure sensor 39
 - 3.2.7 XENSIV™ MEMS digital microphones 39
 - 3.2.8 XENSIV™ 60 GHz RADAR sensor 40
 - 3.2.9 6-axis IMU (accelerometer + gyroscope) 42



Table of contents

3.2.10	3-axis magnetometer	43
3.2.11	QSPI flash memory	44
3.2.12	Wi-Fi + Bluetooth® module interface	45
3.2.13	IO Expansion header	48
3.2.13.1	Expansion headers	48
3.2.13.2	I2C interface connector	50
3.3	Bill of materials	51
	Glossary	52
	Revision history	54
	Trademarks	55
	Disclaimer	56

1 Introduction

1 Introduction

The PSOC™ 6 AI Evaluation Kit enables you to evaluate and develop your applications using the [PSOC™ 62 Series MCU](#) (hereafter called “PSOC™ 6 MCU”) and AIROC™ CYW43439 Wi-Fi & Bluetooth® combo device.

The PSOC™ 6 AI Evaluation Board features a PSOC™ 6 MCU and a CYW43439 Wi-Fi & Bluetooth® combo module, a 512 Mb NOR flash, an onboard programmer/debugger (KitProg3), two user LEDs, USB host, and device features and one push button. The board supports operating voltages from 1.8 V to 3.3 V for the PSOC™ 6 MCU.

PSOC™ 6 is Infineon’s latest ultra-low-power PSOC™, specifically designed for wearables and IoT products. PSOC™ 6 MCU is a true programmable embedded system-on-chip, integrating a 150 MHz Arm® Cortex®-M4. This primary application processor is a 100 MHz Arm® Cortex®-M0+, which supports low-power operations up to 2 MB flash and 1 MB of SRAM, Secure Digital Host Controller (SDHC) supporting SD/SDIO/eMMC interfaces, CAPSENSE™ touch-sensing, and programmable analog and digital peripherals that allow higher flexibility, in-field tuning of the design, and faster time-to-market.

You can use ModusToolbox™ to develop and debug your PSOC™ 6 MCU projects. [ModusToolbox™ software](#) is a set of tools that enable you to integrate Infineon devices into your existing development methodology.

If you are new to PSOC™ 6 MCU, and ModusToolbox™ IDE, see the application note [AN228571 - Getting Started with PSOC™ 6 MCU on ModusToolbox™ software](#) to help you familiarize with the PSOC™ 6 MCU and help you create your own design using the ModusToolbox™ IDE.

1.1 Kit contents

CY8CKIT-062S2-AI PSOC™ 6 AI Evaluation Kit includes:

- PSOC™ 6 AI Evaluation Board
- Inlay card (a printed QR code points to a getting started webpage)

1 Introduction

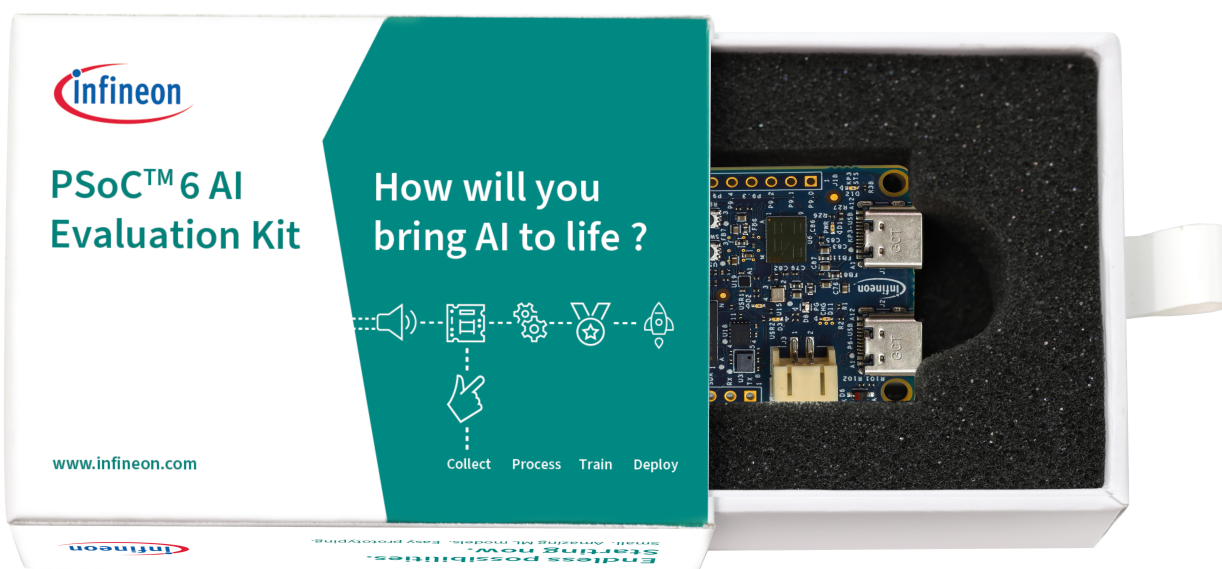
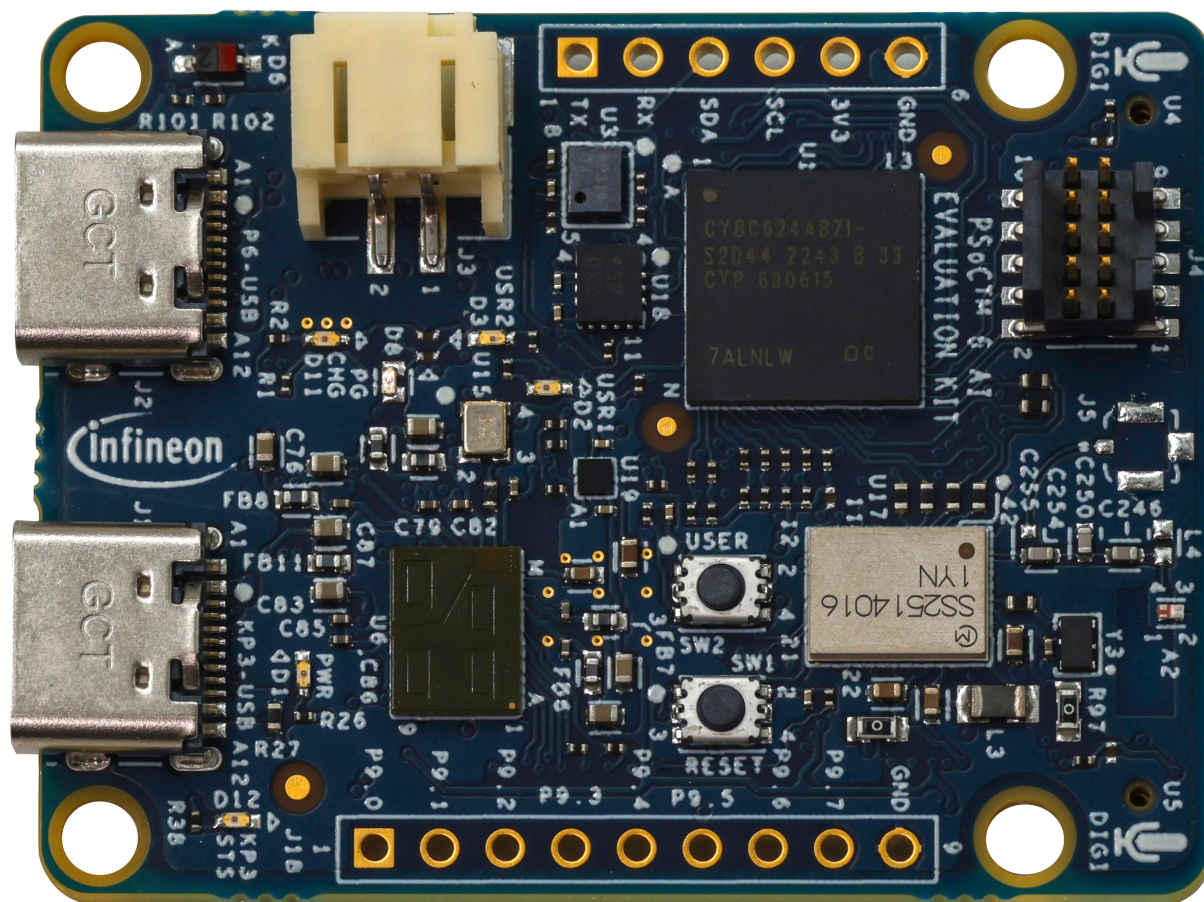

1 Introduction



Figure 1 Kit contents

1.2 Getting started

This guide will help you get acquainted with this evaluation kit:

- The [Kit operation](#) chapter describes the major features of the PSOC™ 6 AI Evaluation Board and its functionalities, such as programming and debugging
- The [Hardware](#) chapter provides a detailed hardware description, kit schematics, and the bill of materials (BOM)
- Application development using PSOC™ 6 AI Evaluation Board is supported in ModusToolbox™ software. For the latest software support for this development kit, including the different development ecosystems, see the [AN228571 - Getting Started with PSOC™ 6 MCU on ModusToolbox™ software](#).
 - ModusToolbox™ software is a free development ecosystem that includes the ModusToolbox™ IDE. Using ModusToolbox™ IDE, you can enable and configure device resources, middleware libraries, program and debug the device. You can download the software from the [ModusToolbox™ home page](#)
- [DEEPCRAFT™ Studio](#) supports the development of machine learning models. DEEPCRAFT™ Studio is a development platform for machine learning on edge devices. Its work flow is optimized for embedded devices
- There are various code examples to evaluate the PSOC™ 6 AI Evaluation Board, which familiarizes you with PSOC™ 6 MCU and creates your own design. These examples can be accessed through ModusToolbox™

1 Introduction

Project Creator tool. Alternatively, you can visit [Code examples for ModusToolbox™ software](#) page to access these examples

1.3 Board details

The PSoC™ 6 AI Evaluation Board has the following features:

- PSoC™ 6 MCU – CY8C624ABZI-S2D44. See the device [datasheet](#)
- Murata LBEE5KL1YN module and Bluetooth® functionality based on CYW43439
- 512 Mbit external Quad SPI NOR flash that provides fast, expandable memory for data and code
- 6-axis motion sensor (BMI270), magnetometer (BMM350), barometric pressure sensor (DPS368), and RADAR sensor (BGT60TR13C) for data collection
- KitProg3 onboard SWD programmer/debugger with USB-UART and USB-I2C bridge functionality
- Supports 1.8 V and 3.3 V operation of PSoC™ 6 MCU
- Two user LEDs, a user button, and a reset button for PSoC™ 6 MCU
- One mode selection button and one Status LED for KitProg3

The following figure shows the pinout of the evaluation board.

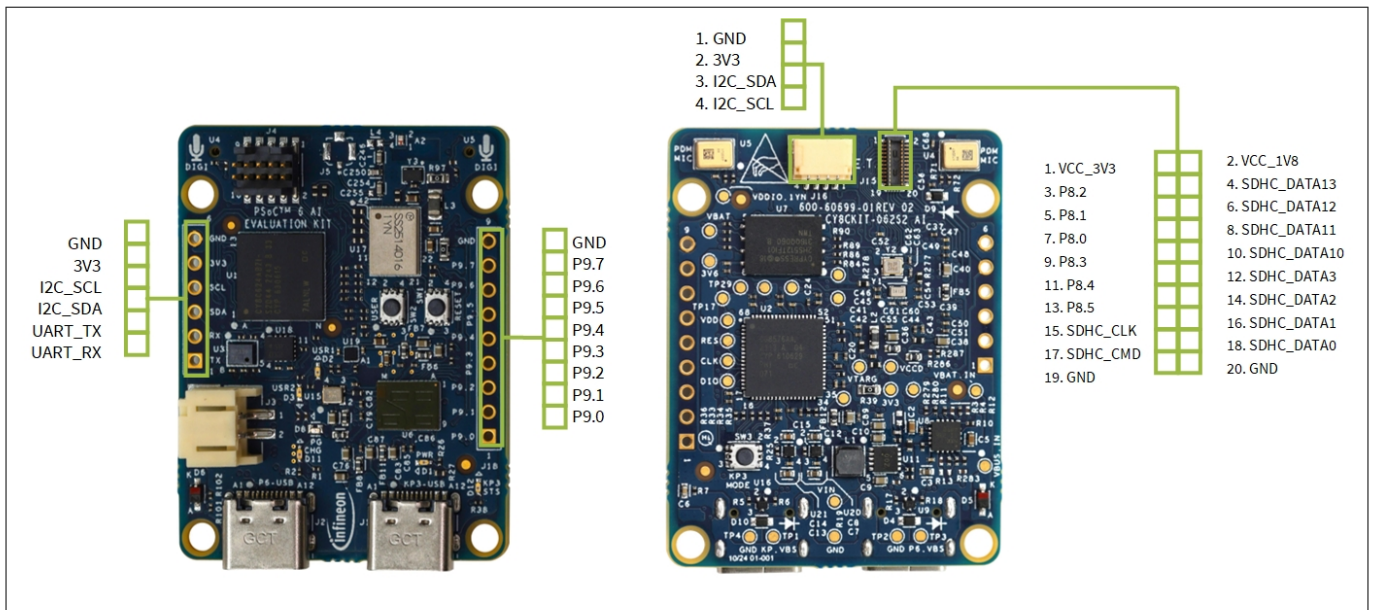

Figure 2 Board pinout

Table 2 Board pinout

PSOC™ 6 pin	Primary onboard function	Secondary onboard function	Connection details
XRES	Hardware Reset	-	-
P0.0	WCO IN	-	-
P0.1	WCO OUT	-	-
P0.2	I2C SCL	-	-
P0.3	I2C SDA	-	-
P0.4	INT Pin for IMU sensor	-	-

(table continues...)

1 Introduction

Table 2 (continued) Board pinout

PSOC™ 6 pin	Primary onboard function	Secondary onboard function	Connection details
P1.0	INT Pin for magnetometer	-	-
P1.4	INT Pin for Pressure sensor	-	-
P1.5	INT Pin for IMU sensor	-	-
P2.0	SDIO DATA0	-	-
P2.1	SDIO DATA1	-	-
P2.2	SDIO DATA2	-	-
P2.3	SDIO DATA3	-	-
P2.4	SDIO CMD	-	-
P2.5	SDIO CLK	-	-
P3.0	BT UART TXD	-	BT UART TXD pin of the Wi-Fi/Bluetooth® module
P3.1	BT UART RXD	-	BT UART RXD pin of the Wi-Fi/Bluetooth® module
P3.2	BT UART CTS	-	BT UART CTS pin of the Wi-Fi/Bluetooth® module
P3.3	BT UART RTS	-	BT UART RTS pin of the Wi-Fi/Bluetooth® module
P3.4	BT REG ON	-	BT REG ON pin of the Bluetooth® module
P3.5	BT DEV WAKE	-	BT DEV WAKE pin of the Wi-Fi/Bluetooth® module
P3.6	WL REG ON	-	WL REG ON pin of the Wi-Fi module
P4.0	BT HOST WAKE	-	BT HOST WAKE pin of the Wi-Fi/Bluetooth® module
P4.1	WL HOST WAKE	-	WL HOST WAKE pin of the Wi-Fi/Bluetooth® module
P5.0	UART_RX	-	-
P5.1	UART_TX	-	-
P5.2	User button	-	-
P5.3	User LED (red)	-	-
P5.4	User LED (red)	-	-
P6.4	PSOC™ 6 MCU JTAG TDO/SWD SWO	-	-

(table continues...)

1 Introduction

Table 2 (continued) Board pinout

PSOC™ 6 pin	Primary onboard function	Secondary onboard function	Connection details
P6.6	PSOC™ 6 MCU JTAG TMS/SWD SWDIO	-	-
P6.7	PSOC™ 6 MCU JTAG TCK/SWD SWCLK	-	-
P10.4	PDM Clock	-	-
P10.5	PDM DATA	-	-
P11.0	RSPI_IRQ	-	IRQ for Radar
P11.1	RXRES_L	-	Reset for Radar
P11.2	QSPI_SS	-	-
P11.3	QSPI FLASH DATA3	-	-
P11.4	QSPI FLASH DATA2	-	-
P11.5	QSPI FLASH DATA1	-	-
P11.6	QSPI FLASH DATA0	-	-
P11.7	QSPI FLASH CLK	-	-
P12.0	RSPI_MOSI	-	MOSI Pin for Radar sensor
P12.1	RSPI_MISO	-	MISO Pin for Radar sensor
P12.2	RSPI_CLK	-	CLK Pin for Radar sensor
P12.3	RSPI_CS	-	CS Pin for Radar sensor
P12.6	ECO IN	-	-
P12.7	ECO OUT	-	-

1.4 Additional learning resources

- Infineon provides a wealth of data at [PSOC™ 6 Arm™ Cortex® -M4/M0+](#) to help you select the right PSOC™ device for your design and to help you quickly and effectively integrate the device into your design
- Depending on the use case, DEEPCRAFT™ Studio supports the creation of a new [machine learning model](#)

1.5 Technical support

For assistance, go to [Infineon support](#). Visit community.infineon.com to ask your questions in the Infineon developer community.

You can also use the [Self-help \(Technical Documents\)](#) support resources for quick assistance.

1 Introduction

1.6 Documentation conventions

Table 3 Document conventions for guide

Convention	Usage
Courier New	Displays file locations, user entered text, and source code: C:\...cd\icc\
Italics	Displays file names and reference documentation: Read about the <i>sourcefile.hex</i> file in the PSOC™ Creator user guide.
File > Open	Represents menu paths: File > Open > New Project
Bold	Displays commands, menu paths, and icon names in procedures: Click File icon and then click Open .
Times New Roman	Displays an equation: $2 + 2 = 4$
Text in gray boxes	Describes cautions or unique functionality of the product

2 Kit operation

2 Kit operation

This chapter introduces you to various features of the PSOC™ 6 AI Evaluation board, including the theory of operation and the onboard KitProg3 programming and debugging functionality, USB-UART, and USB-I2C bridges.

2.1 Theory of operation

The PSOC™ 6 AI Evaluation Board is built around a PSOC™ 6 MCU. The following figure shows the block diagram of the PSOC™ 6 MCU device used on the board. For details on device features, see the [device datasheet](#).

2 Kit operation

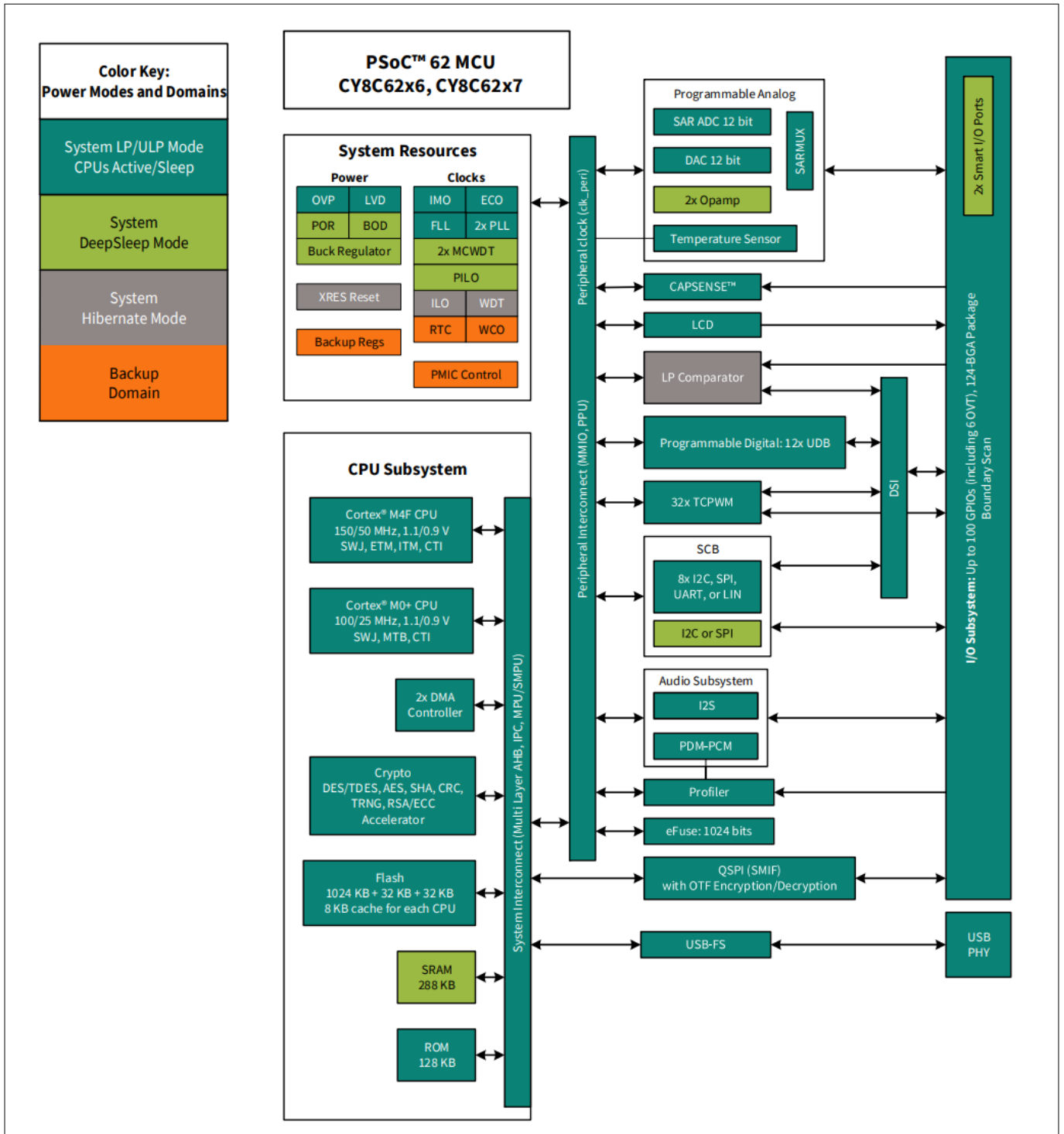

Figure 3 PSOC™ 6 MCU block diagram

The following figure shows the block diagram of the AI evaluation board.

2 Kit operation

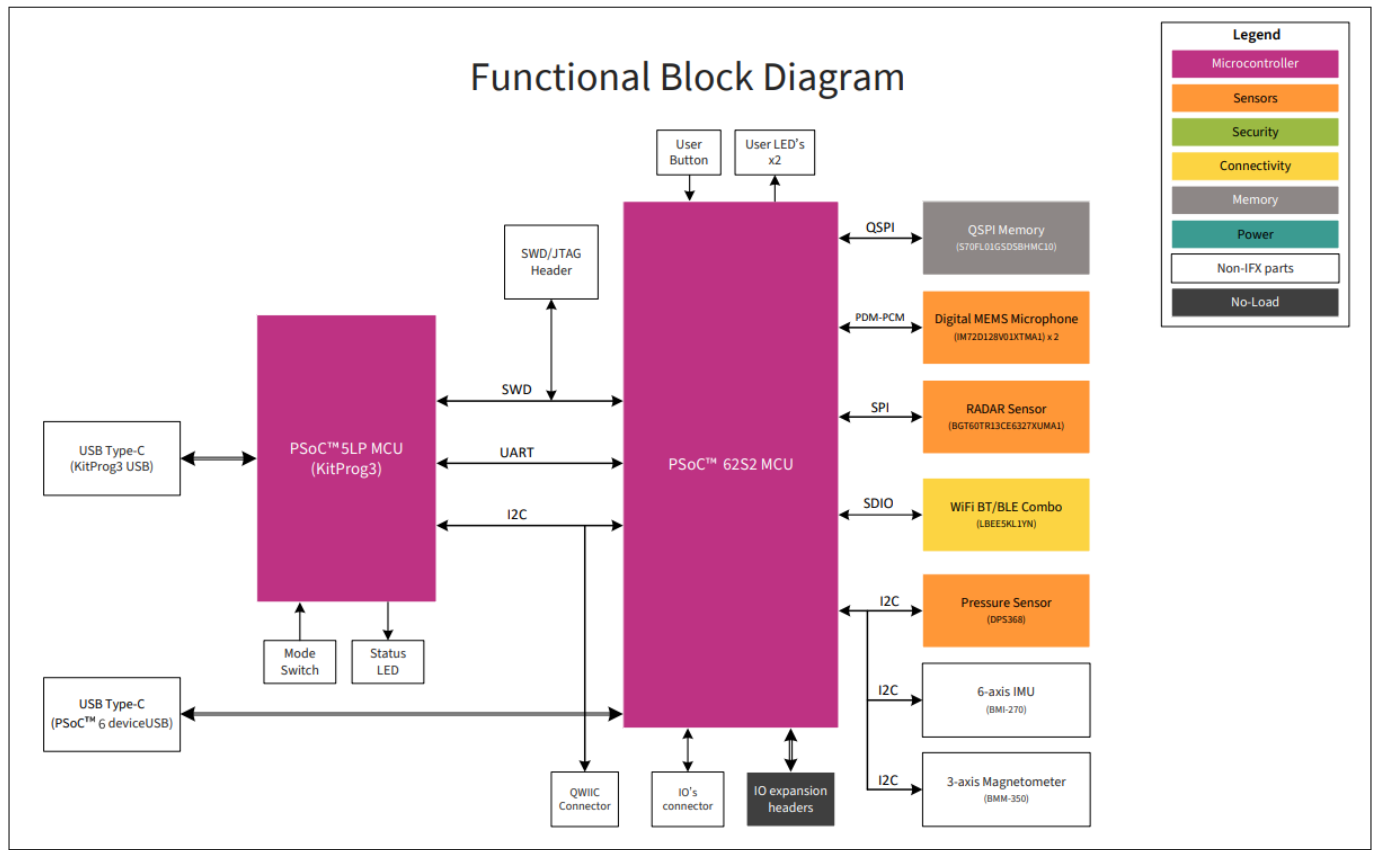

Figure 4 PSoC™ 6 AI Evaluation Kit block diagram

Figure 5 and Figure 6 show the markup of the evaluation board.

2 Kit operation

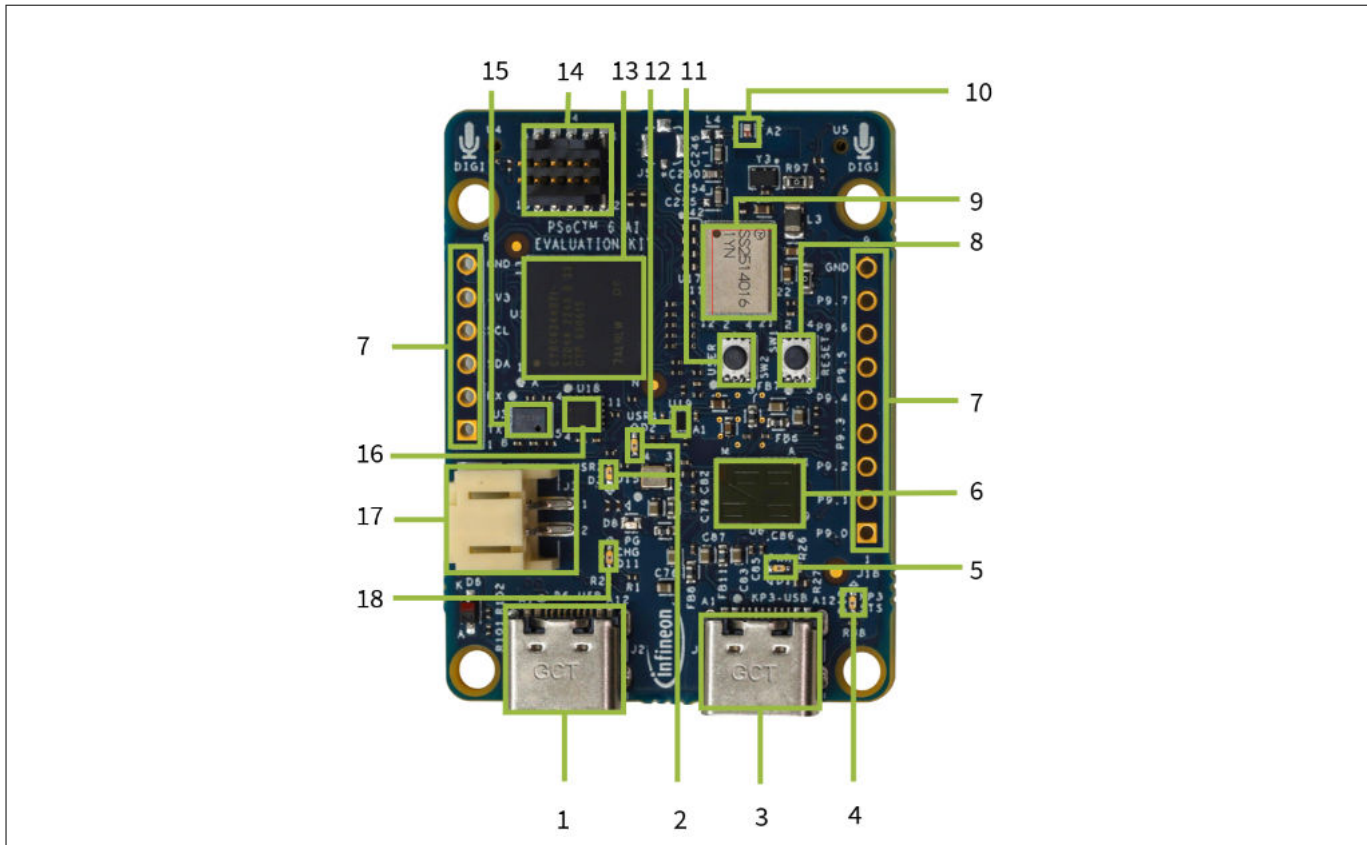

Figure 5 PSOC™ 6 AI Evaluation Board - Top view

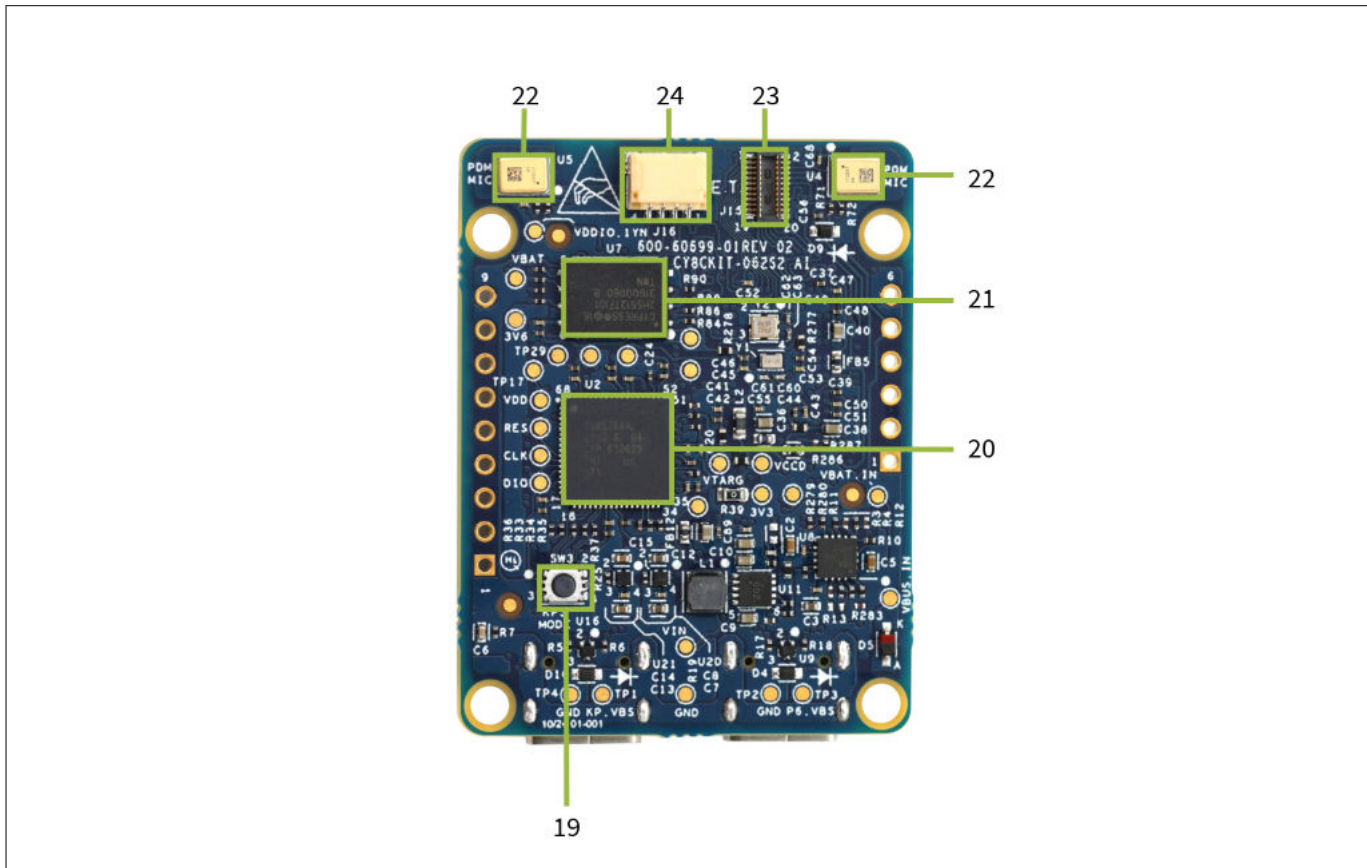

Figure 6 PSOC™ 6 AI Evaluation Board - Bottom view

2 Kit operation

PSOC™ 6 AI Evaluation Board has the following peripherals:

1. **PSOC™ 6 USB device connector (J2):** The USB cable can be connected between this USB connector and the PC to use the PSOC™ 6 MCU USB device application.
2. **User LEDs (D2, D3):** These onboard LEDs can be controlled by the PSOC™ 6 MCU. The LEDs are active HIGH, so the pins must be driven to high for turning on the LEDs.
3. **KitProg3 USB connector (J1):** The USB cable connects between this USB connector and the PC to use the KitProg3 onboard programmer and debugger, and to provide power to the board.
4. **KitProg3 status LED (D12):** This red LED indicates the status of KitProg3. For details on the KitProg3 status, see the [KitProg3 User Guide](#).
5. **Power LED (D1):** This red LED indicates the status of power supplied to the board.
6. **RADAR sensor (U6):** The kit comprises the XENSIV™ BGT60TR13C radar sensor.
7. **Expansion IO headers (J17, J18):** This header brings out a few IOs for general purpose applications.
8. **PSOC™ 6 MCU reset button (SW1):** This button is used to reset PSOC™ 6 MCU. It connects the PSOC™ 6 MCU reset (XRES) pin to the ground.
9. **CYW43439-based Murata Type 1YN module:** The Type 1YN module supports Wi-Fi 802.11b/g/n + Bluetooth® 5.2 BR/EDR/LE up to 65 Mbps PHY data rate on Wi-Fi and 3 Mbps PHY data rate on Bluetooth®. The WLAN section supports the SDIO v2.0 interface, and the Bluetooth® section supports high-speed 4-wire UART interface and PCM for audio data. Type 1YN module facilitates integration into size and power-sensitive applications, such as IoT applications, handheld wireless systems, gateway.
10. **Wi-Fi/BT antenna:** This is the onboard antenna connected to the Wi-Fi and Bluetooth® module.
11. **PSOC™ 6 MCU user button (SW2):** This button can be used to provide input to the PSOC™ 6 MCU. Note that by default, this button connect the PSOC™ 6 MCU pin to ground when pressed; hence, you need to configure the PSOC™ 6 MCU pin as a digital input with a resistive pull-up for detecting the button press. It also provides a wake-up source in low-power modes of the device.
12. **3-axis magnetometer (U19):** This kit contains a motion sensor with a 3-axis magnetometer, which can be interfaced with a PSOC™ 6 MCU via I2C.
13. **PSOC™ 6 MCU (U1):** This kit is designed to highlight the features of the PSOC™ 6 MCU.
14. **PSOC™ 6 MCU program and debug header (J4):** This 10-pin header allows you to program and debug the PSOC™ 6 MCU using an external programmer such as [MiniProg4](#).
15. **XENSIV™ digital barometric air pressure sensor (U3):** This is an Infineon digital MEMS barometric pressure sensor (DPS368) with a built-in temperature sensor. This sensor uses I2C to transfer the sensor data.
16. **6-axis IMU (U18):** This kit contains a BMI270 motion sensor with a 6-axis accelerometer and gyroscope. It can interface via I2C with a PSOC™ 6 MCU.
17. **Li-ion battery connector (J3):** This is used for connecting a Li-ion battery.
18. **Charging LED:** LED that indicates the Li-ion battery charging status by glowing continuously. If the Li-ion battery is not connected, and this LED does not glow.
19. **KitProg3 programming mode selection button (SW3):** This button allows you to switch between various modes of operation of KitProg3 (CMSIS-DAP BULK, CMSIS-DAP HID). For more details, see the [KitProg3 User Guide](#).
20. **KitProg3 (PSOC™ 5LP) programmer and debugger (CY8C5868LTI-LP039, U2):** The PSOC™ 5LP device (CY8C5868LTI-LP039), serving as KitProg3, is a multi-functional system that includes a SWD programmer, debugger, USB-I2C bridge, and USB-UART bridge. For more details, see the [KitProg3 User Guide](#).
21. **512 Mbit Quad-SPI NOR flash (U7):** The S25HS512T NOR flash of 512 Mbit capacity is connected to the Quad SPI interface of the PSOC™ 6 MCU.
22. **XENSIV™ digital MEMS microphones (U4, U5):** These are two Infineon digital MEMS microphones that are used to capture sound and generate digital audio data, which is transferred through the PDM interface.

2 Kit operation

23. **Expansion IO connectors (J15):** This connector brings out a few IOs for general purpose applications.
24. **I2C interface (J16):** This kit contains a QWIIC interface, which can use the I2C protocol to allow multiple “slave” digital integrated circuits (“chips”) to communicate with one or more “master” chips with a mere two wires.

2.2 Using the OOB example

DEEPCRAFT™ streaming protocol for ModusToolbox™/PSOC™ 6.

The kit includes a preprogrammed code example that allows for the collection of data from the USB port and storage of this data in DEEPCRAFT™ Studio. This code example supports collecting data from an IMU, microphone, magnetometer, barometric pressure sensor, and radar using DEEPCRAFT™ Studio.

After flashing the streaming firmware, you can collect various types of data from multiple sensors, including:

- **Audio data:** Pulse density modulation (PDM) and pulse code modulation (PCM) audio data can be collected from the microphone at sample rates of 8 kHz or 16 kHz
- **Inertial Measurement Unit (IMU) data:** Data from the 6-axis IMU (accelerometer and gyroscope) can be sampled at frequencies of 50 Hz, 100 Hz, 200 Hz, or 400 Hz. This allows for acceleration and gyroscopic angular rate sensing in each spatial direction. The IMU sensor can be configured to collect data from only the accelerometer, only the gyroscope, or both
- **Magnetometer data:** The 3-axis magnetometer provides data at a sample rate of 50 Hz, 100 Hz, 200 Hz, or 400 Hz, enabling geomagnetic field direction and strength sensing
- **Barometric pressure data:** Data from the barometric pressure sensor can be sampled at a frequency of 8 Hz, 16 Hz, 32 Hz, 64 Hz, or 128 Hz, capturing changes in atmospheric pressure
- **Radar data:** Radar data can be utilized for various applications, including macro presence detection, micro presence detection, gesture recognition, and other use cases

For using the OOB example, see [Getting Started With AI Evaluation Kit](#).

2.3 Creating a project and program/debug using ModusToolbox™ software

The PSOC™ 6 AI Evaluation Board can be programmed and debugged using the onboard KitProg3. KitProg3 is an onboard programmer/debugger with USB-UART and USB-I2C functionality. Infineon's PSOC™ 5LP device is used to implement KitProg3 functionality. For more details on the KitProg3 functionality, see [KitProg3 User Guide](#).

Programming and debugging using ModusToolbox™

This section gives a quick overview of programming and debugging using ModusToolbox™. For detailed instructions, see **Help > ModusToolbox IDE Documentation > User Guide**.

1. Connect the board (**J1**) to the PC using the USB cable. It enumerates as a USB composite device if you are connecting it to your PC for the first time. KitProg3 can operate either in CMSIS-DAP Bulk mode (default) or in CMSIS-DAP HID mode. KitProg3 also supports CMSIS-DAP Bulk mode with two UARTs. Programming is faster with the Bulk mode. The status LED is always ON in Bulk mode; ramping at 1 Hz rate in HID mode. Press and release the mode select button (SW3) to switch between these modes. If you do not see the desired LED status, see the [KitProg3 user guide](#) for details on the KitProg3 status and troubleshooting instructions.

Note:- By default only Bulk mode is enabled.

2. In the ModusToolbox™ IDE, import the desired code example (application) into a new workspace.
 - a. Click **New Application** from **Quick Panel**

2 Kit operation

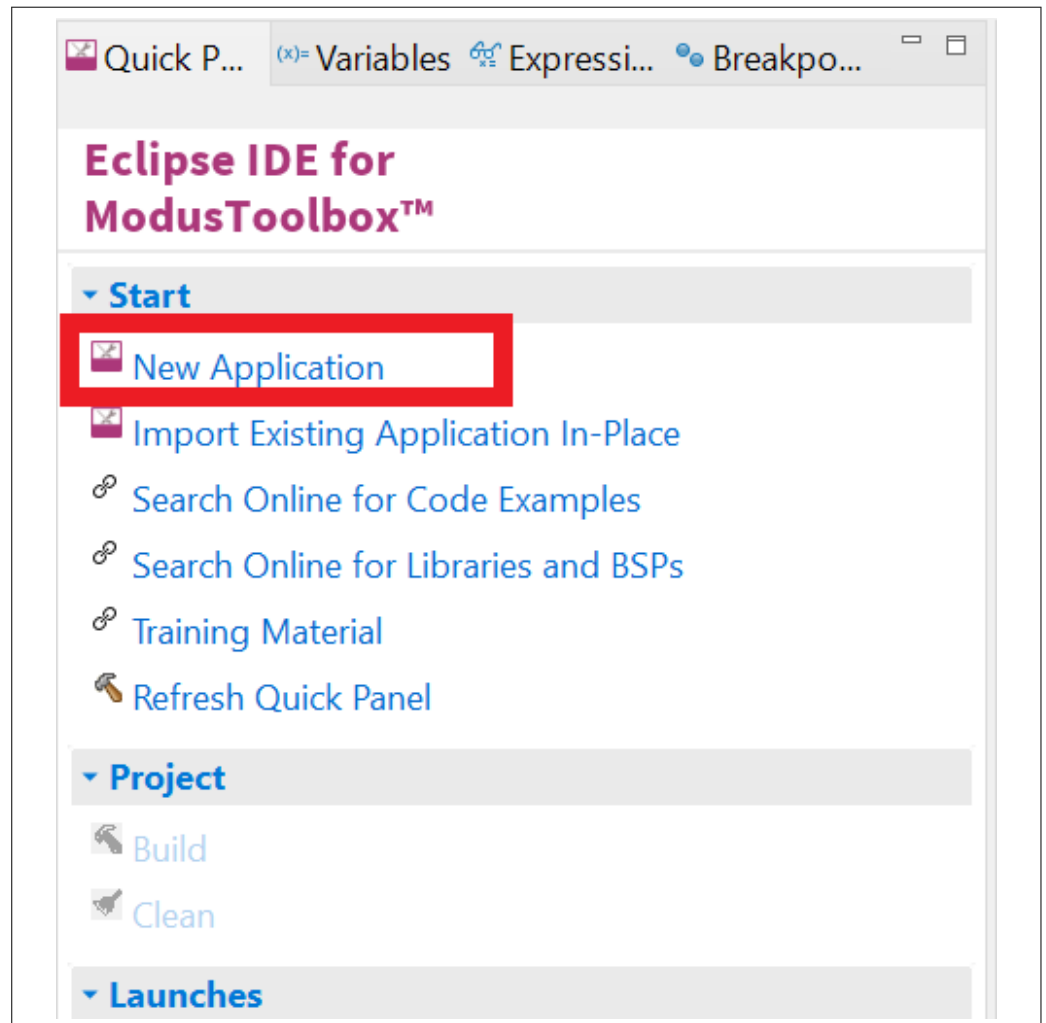

Figure 7 Create new application

- b. Select the CY8CKIT-062S2-AI in the **Choose BSP Target** window and click **Next**.

2 Kit operation

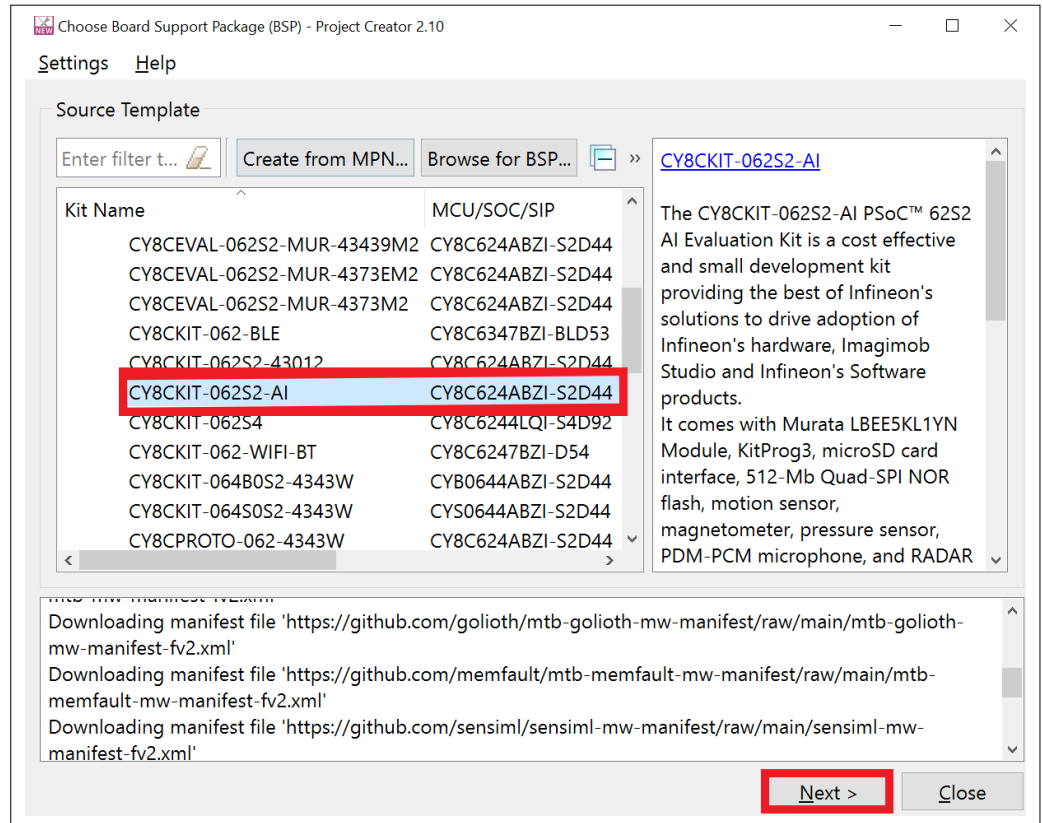

Figure 8 New application creation: Choose target BSP

- c. Select the application in the **Select Application** window and click **Create**.

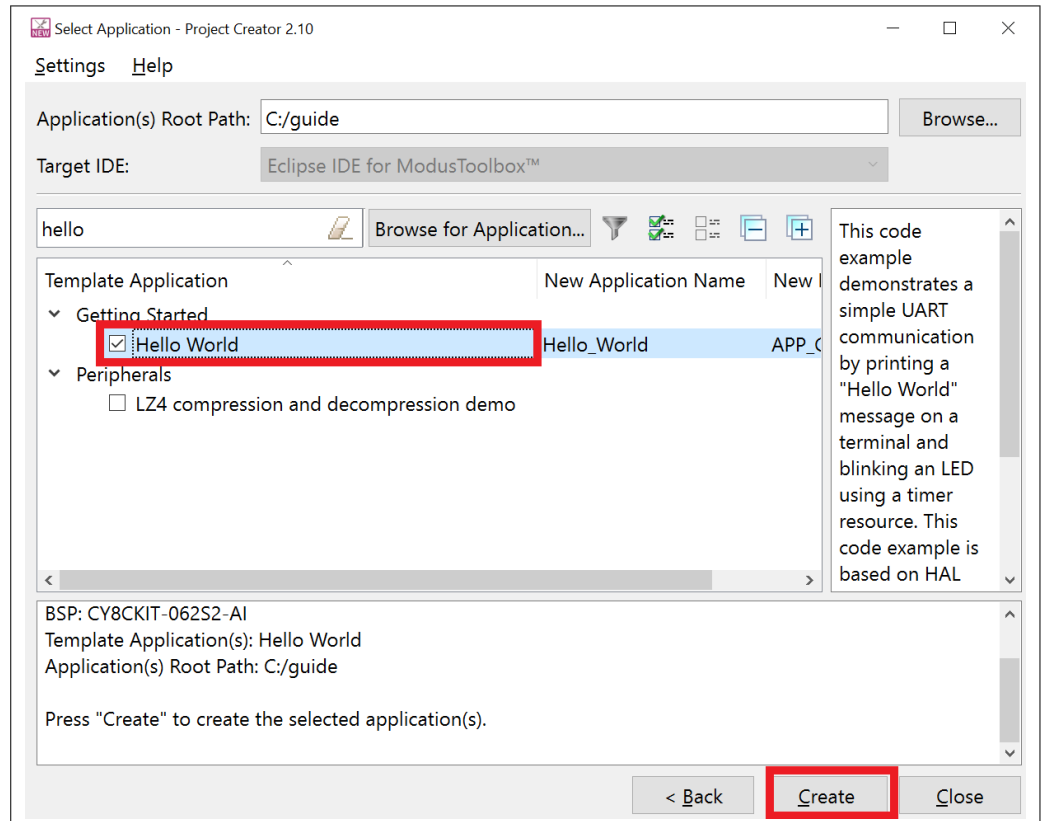

Figure 9 New application creation

2 Kit operation

- 3. To build and program a PSOC™ 6 MCU application in the Project Explorer, select **<App_Name> project**. In the **Quick Panel**, scroll to the **Launches** section and click the **<App_Name> Program (KitProg3_MiniProg4)** configuration, as shown in the following figure.

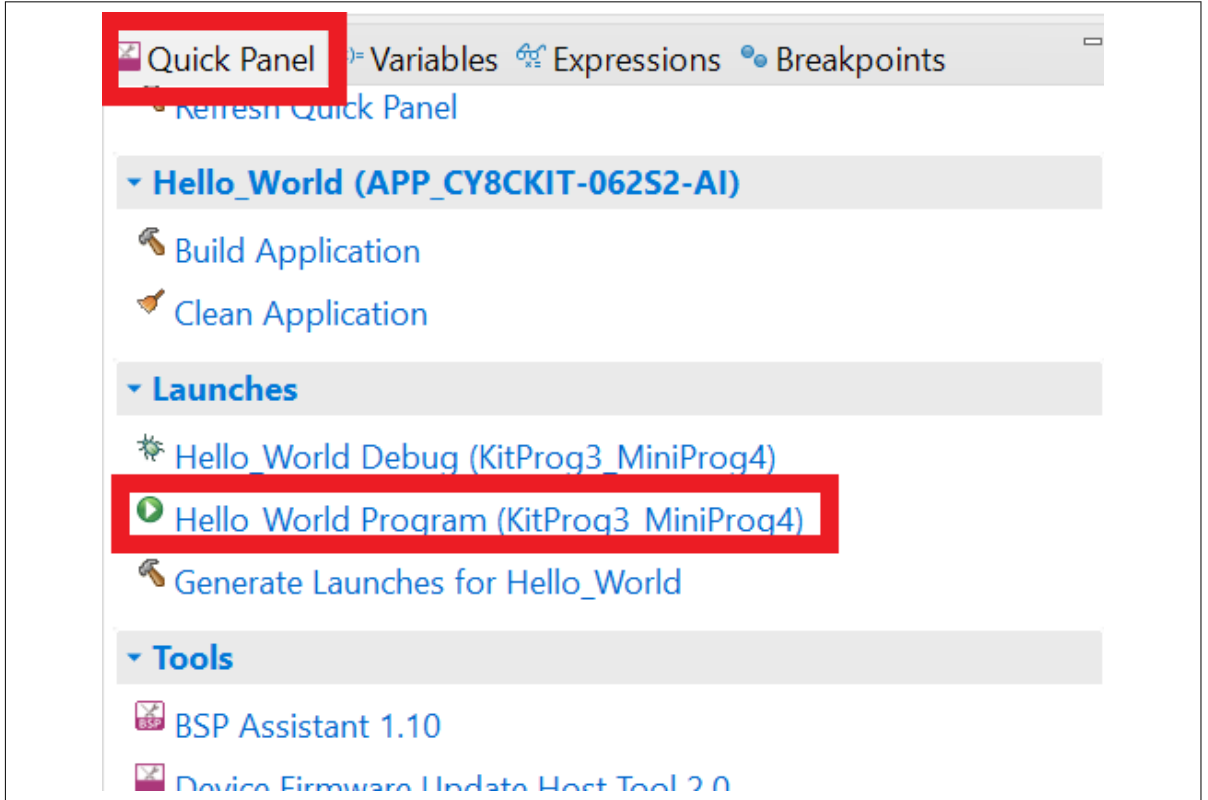

Figure 10 Programming in ModusToolbox™

- 4. ModusToolbox™ has an integrated debugger. To debug a PSOC™ 6 MCU application in the Project Explorer, select the **<App_Name> project**. In the **Quick Panel**, scroll to the **Launches** section and click the **<App_Name> Debug (KitProg3_MiniProg4)** configuration as shown in the following figure. For a detailed explanation on how to debug using ModusToolbox™, refer [ModusToolbox™ user guide](#).

2 Kit operation

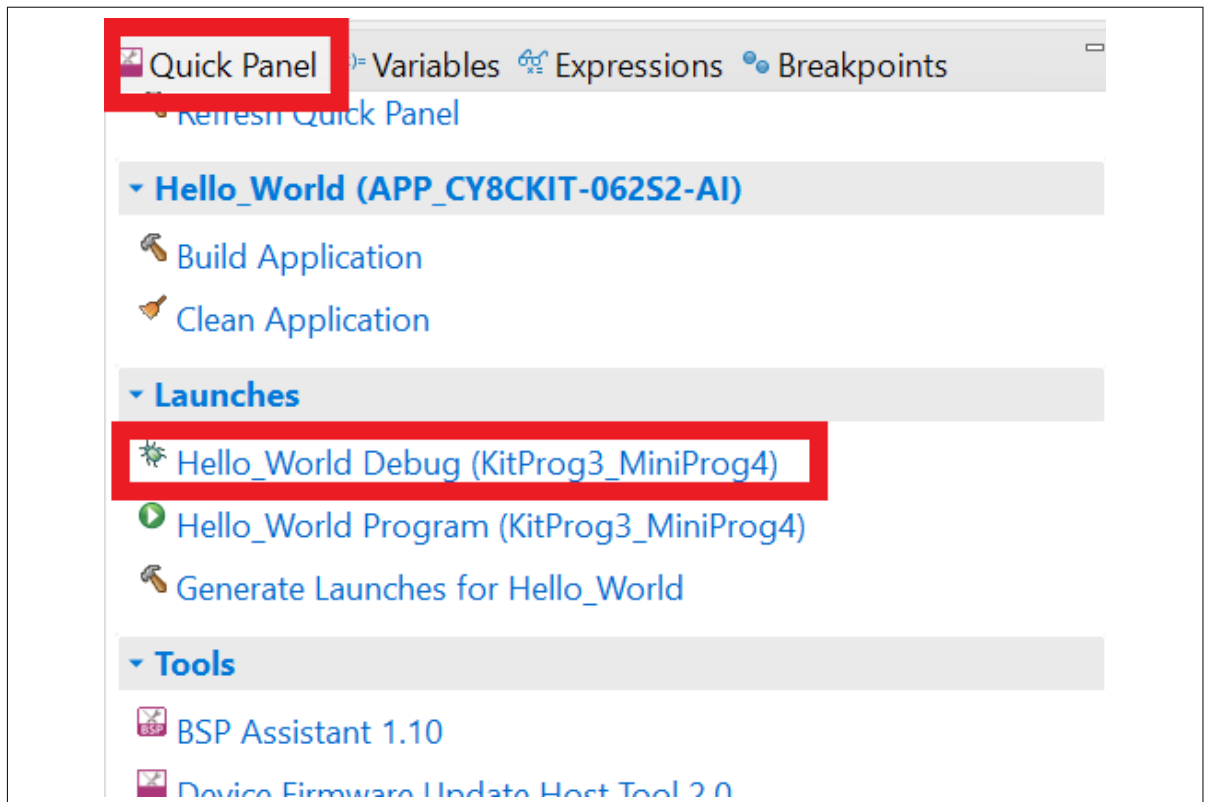

Figure 11 Debugging in ModusToolbox™

3 Hardware

3 Hardware

3.1 Schematics

Refer to the schematic files available on the [kit webpage](#).

3.2 Hardware functional description

3.2.1 Power supply system

3.2.1.1 Power supply inputs

Power supply input options for the kit.

The power supply system on this board is versatile, allowing the board to be supplied from any of the following sources:

- 5 V input from onboard KitProg3 Type-C USB connector (**J1**)
- 5 V input from the PSOC™ 6 MCU Type-C USB connector (**J2**)
- 3.6 V-4.2 V from the battery input connector supporting Li-ion for charging (**J3**)

The power supply system is designed to provide 3.3 V (core and I/O), 1.8 V (I/O), and 2.7 V-4.2 V (VBAT) operating voltages to the PSOC™ 6 MCU and 5 V for the PSOC™ 5LP based KitProg3 operation. In addition, the voltages of 1.8 V, 3.3 V, and 5 V rails are also used for the operation of PSOC™ 6 MCU, memory, and various sensors available on the kit.

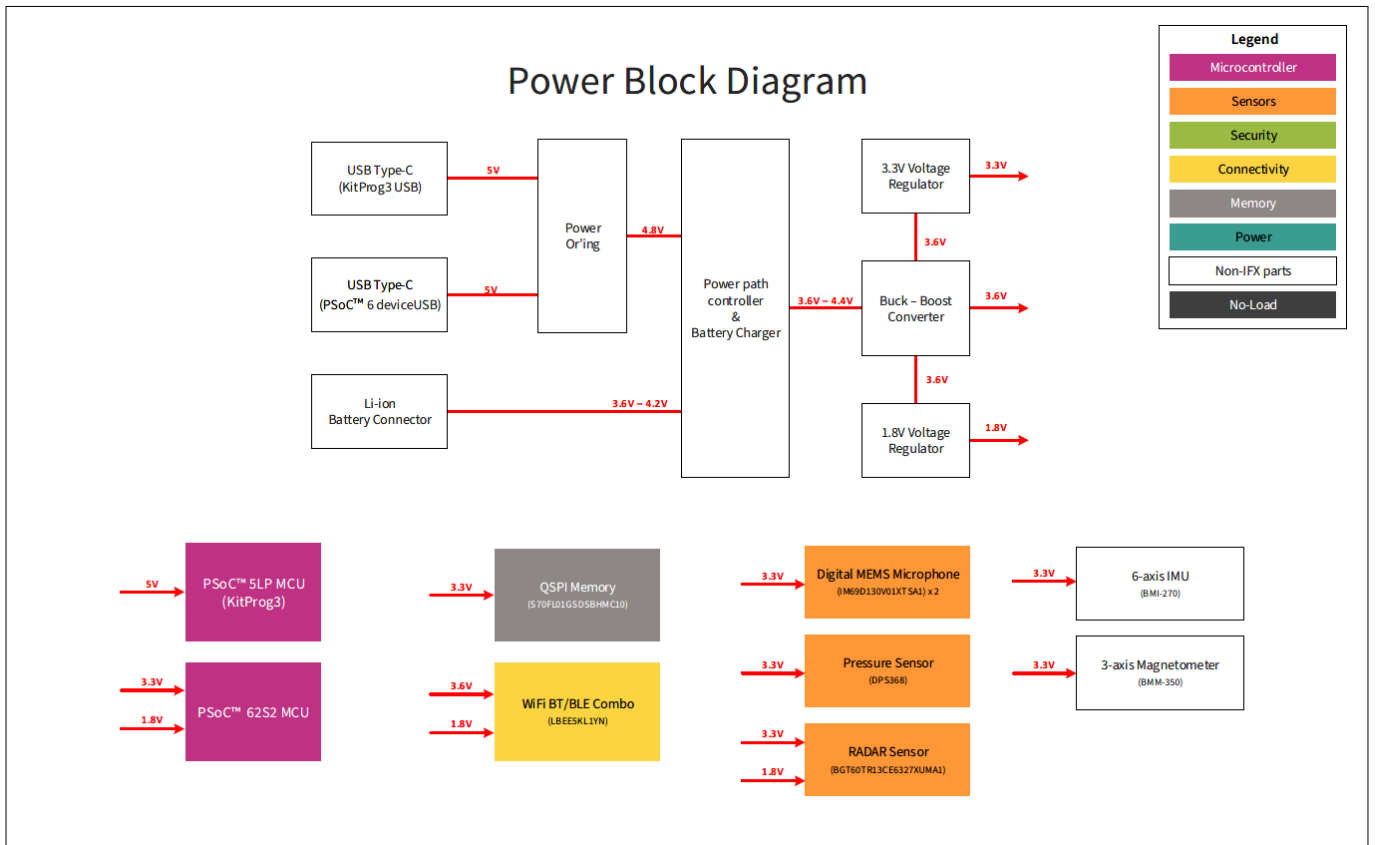
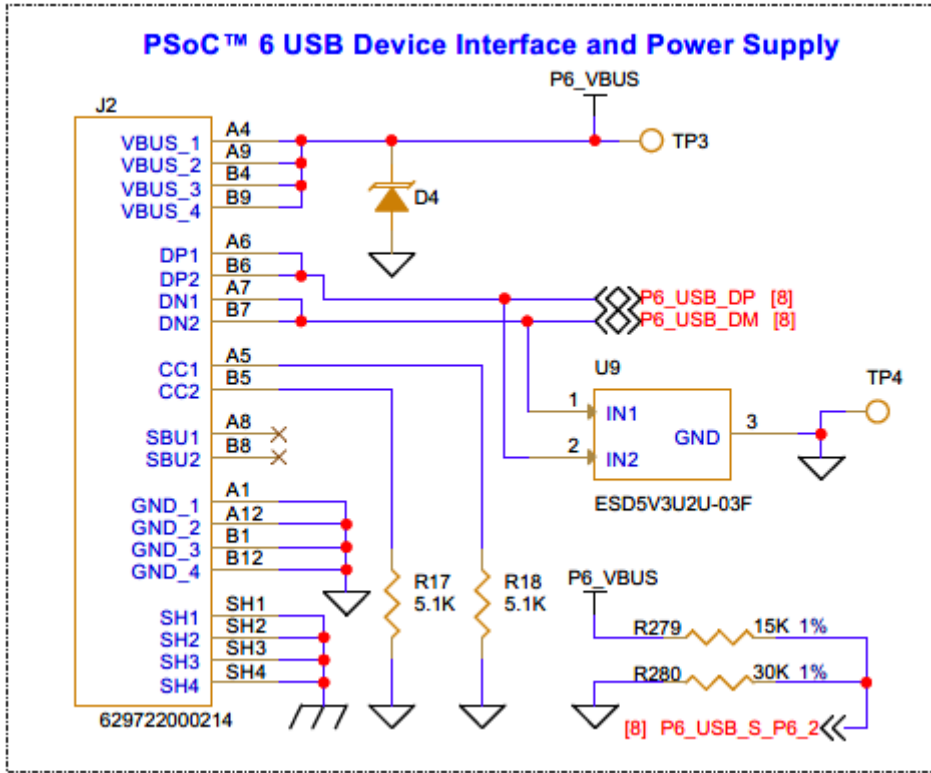
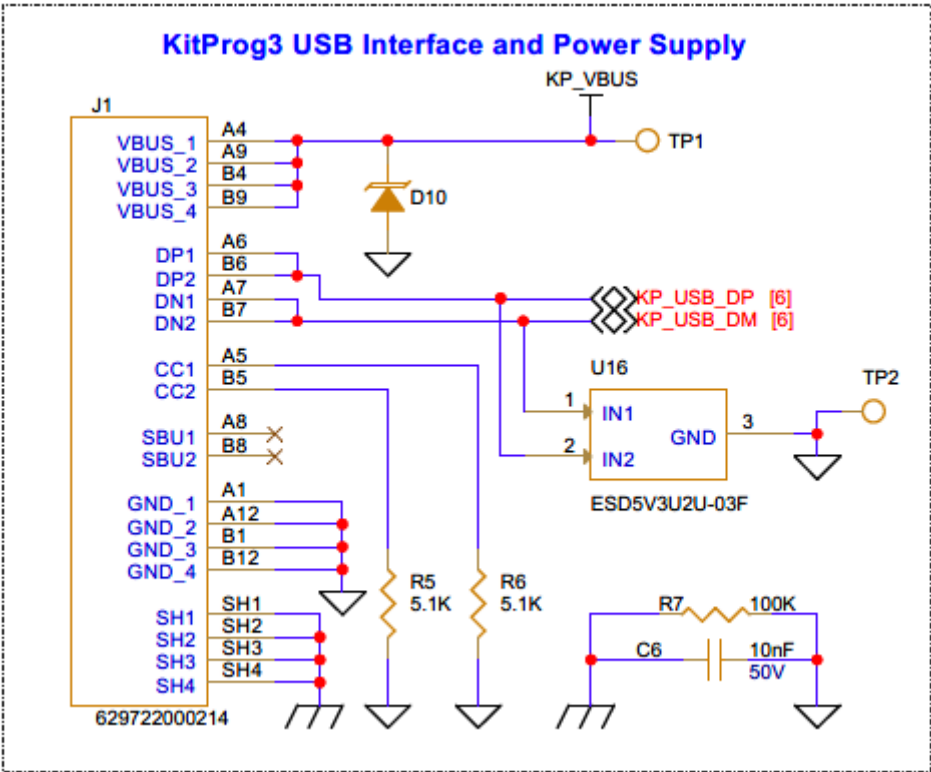

Figure 12 Block diagram of power architecture

3 Hardware



3 Hardware

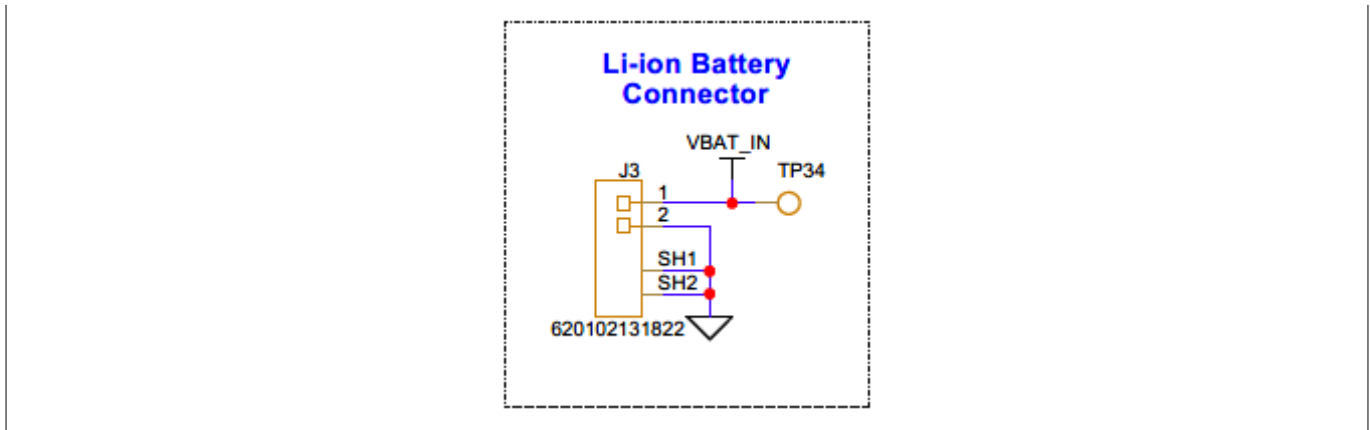

Figure 13 Schematic of power supply inputs of evaluation kit

The KitProg3 Type-C USB connector (**J1**) and PSOC™ 6 device USB connector (**J2**) can only provide 5 V/3 A, as it is hard configured by pulling the CC1 and CC2 lines to GND by the 5.1 KΩ pull-down resistor (**R5**, **R6** and **R17**, **R18**).

Note: This current rating of 5 V/3 A from **J1** or **J2** is limited to **1A** by the power path controller **U8** and the host power rating capability.

The supply rails KP_VBUS (5 V from **J1**) and P6_VBUS (5 V from **J2**) are combined into VBUS_IN through ‘OR’ing diodes (**D5**, **D6**), as shown in the following figure.

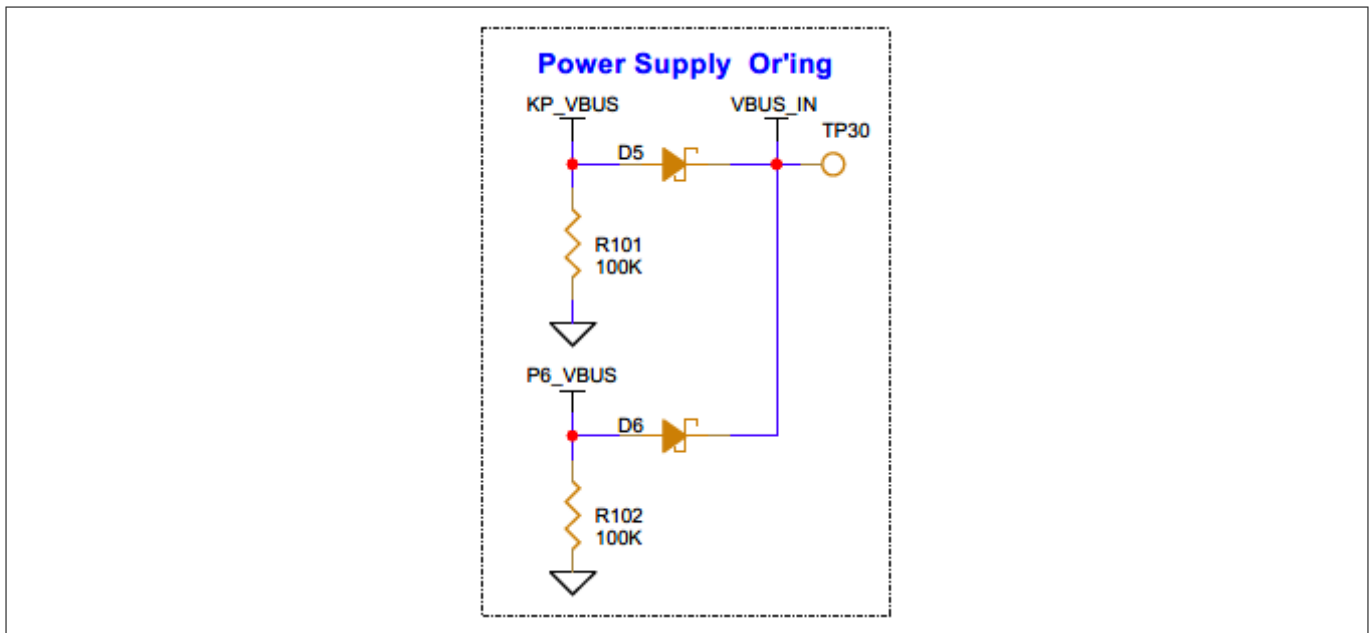

Figure 14 Schematic of power supply Or'ing

The VBUS_IN supply rail serves as an input to the power pathway with a Li-Ion battery charger (**U8**). This pathway is set up with a current limit of **1 A**. If the drawn input current is under this limit, additional current will be utilized to charge the battery connected at **J3**. However, if the drawn input current exceeds this limit, the battery will supply the necessary excess current. The power pathway cannot source this excess without the battery connected, leading to a reduced output voltage. The battery's maximum charging current is **190 mA**.

3 Hardware

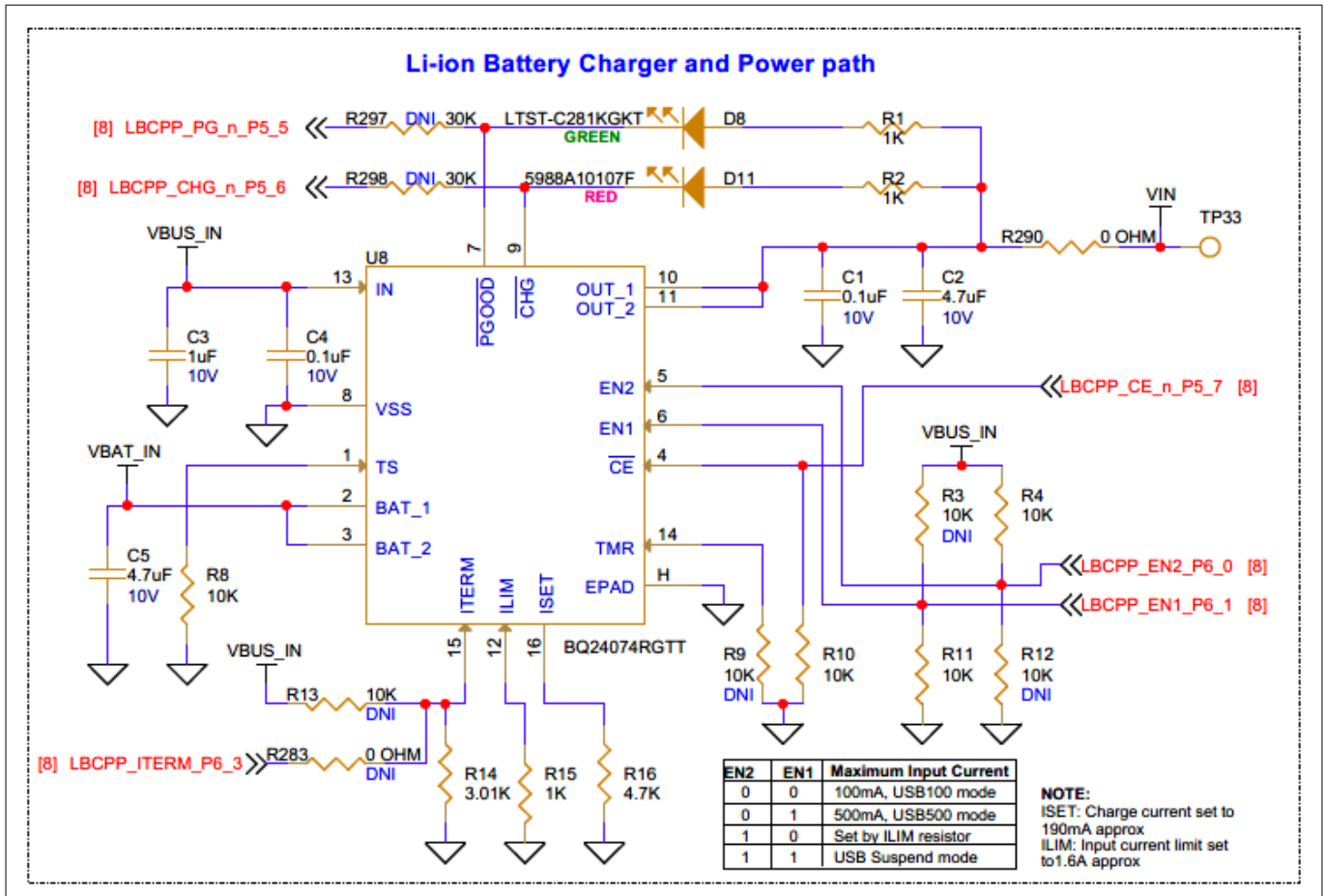

Figure 15 Schematic of Li-Ion battery charger with power path (U8)

LEDs **D8** and **D11** indicate the status of PGOOD (power good) signal (using **D8**) and battery charging (using **D11**).

3.2.1.2 Voltage regulators

Onboard voltage regulators for the power supply system.

There are three voltage regulators on the board:

- 3.6 V buck-boost regulator (**U11**): Powers the Wi-Fi & Bluetooth® module VBAT power supply
- 3.3 V LDO linear voltage regulator (**U20**): Powers the PSOC™ 6 MCU (core and IO domain) and onboard peripherals
- 1.8 V LDO linear voltage regulator (**U21**): Powers the PSOC™ 6 MCU (IO domain) and onboard peripherals

VIN rail powers the 3.6 V buck-boost (**U11**). The VCC3_3V6 rail powers a 3.3 V LDO linear voltage regulator (**U20**) and 1.8 V LDO linear voltage regulator (**U21**).

3 Hardware

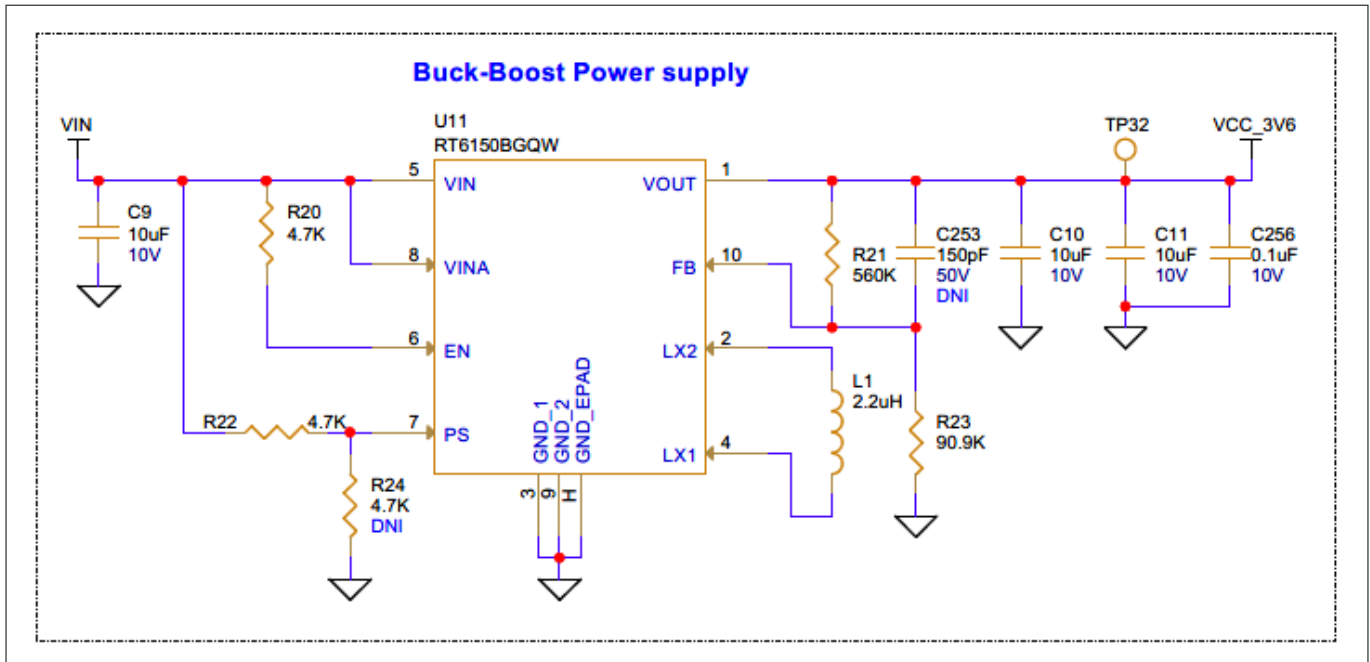

Figure 16 Schematic of buck-boost power supply regulator (U11)

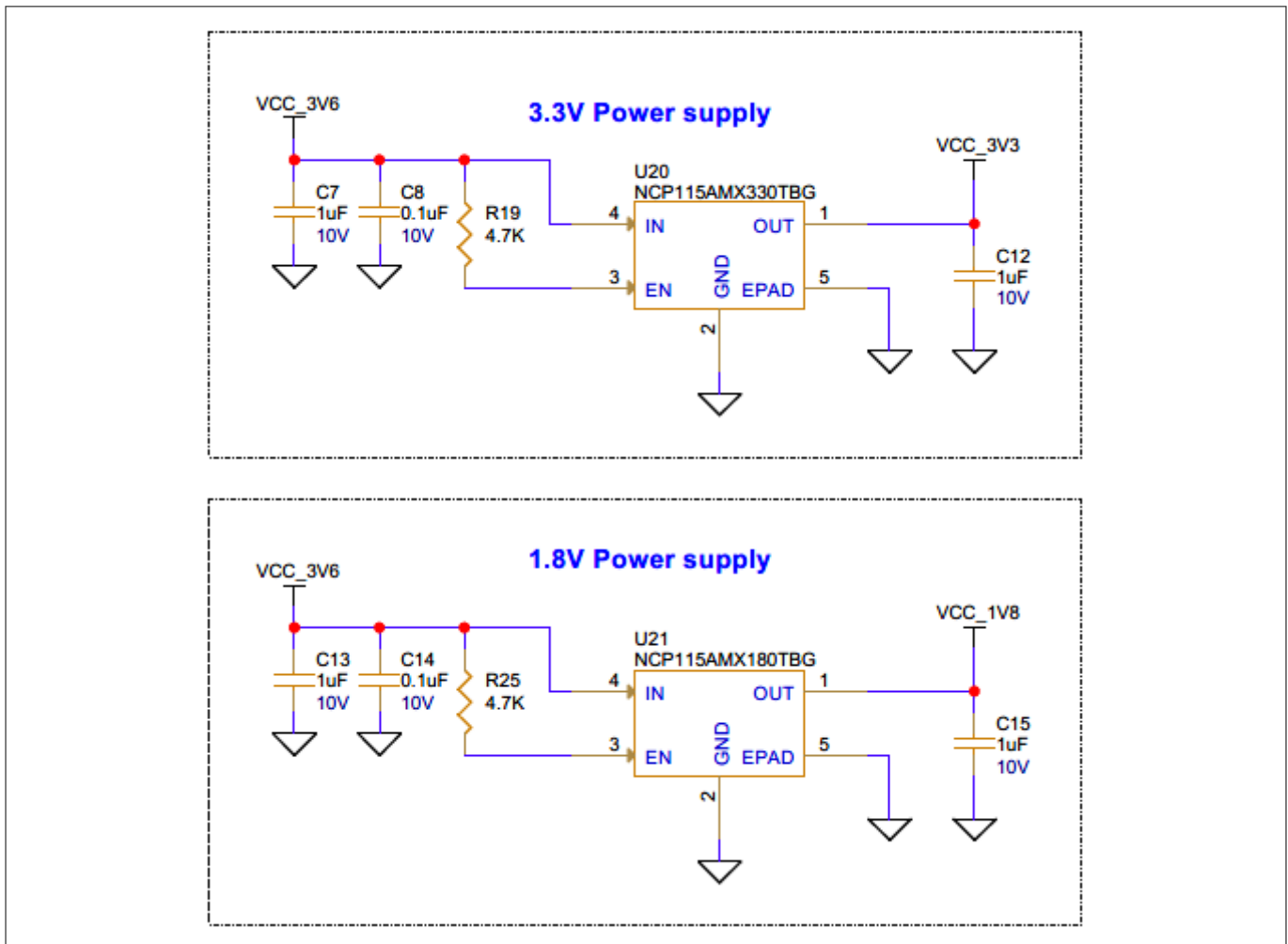

Figure 17 Schematic of 3.3 V and 1.8 V LDO linear voltage regulators (U20, U21)

3 Hardware

3.2.2 PSOC™ 5LP based KitProg3 programmer and debugger

3.2.2.1 PSOC™ 5LP based KitProg3

PSOC™ 5LP based KitProg3 to program and debug the PSOC™ 6 MCU.

The onboard PSOC™ 5LP (CY8C5868LTI-LP039 - U2) device is used as the KitProg3 programmer/debugger to program and debug the PSOC™ 6 MCU. PSOC™ 5LP device is connected to the USB port of a PC through a Type-C USB connector, and to the SWD and other communication interfaces of the PSOC™ 6 MCU.

For more information, see the following:

- [PSOC™ 5LP webpage](#)
- [CY8C58LPxx family datasheet](#)

3 Hardware

3.2.2.2 KitProg3 serial interface with PSOC™ 6

I2C and UART interface between the PSOC™ 5LP of KitProg3 and PSOC™ 6 MCU

In addition to being used as an onboard programmer/debugger using the SWD/JTAG interface, the PSOC™ 5LP device also functions as an interface for the USB-UART and USB-I2C bridges. The PSOC™ 5LP device also functions as an interface for the USB-UART and USB-I2C bridges. The USB-Serial pins of the PSOC™ 5LP devices are hard-wired to the I2C/UART pins of the PSOC™ 6 MCU. The I2C pins are also available on the expansion I/O header, and connected to all I2C interface-based sensors. Therefore, the PSOC™ 5LP device can be used to control a sensor with the I2C interface and PSOC™ 6 MCU.

Table 4 Pin assignments of serial interface between PSOC™ 5LP and PSOC™ 6

PSOC™ 5LP signal	PSOC™ 6 I/O (signal)	Logic level
P6_SWCLK_P6_7	P6[7]	3.3 V
P6_SWDIO_P6_6	P6[6]	3.3 V
P6_RESET_L	XRES	3.3 V
I2C_SDA_P0_3	P0[3]	3.3 V
I2C_SCL_P0_2	P0[2]	3.3 V
KP_UART_TX_P5_0	P5[0]	3.3 V
KP_UART_RX_P5_1	P5[1]	3.3 V

3.2.2.3 KitProg3 based voltage measurement

PSOC™ 5LP of KitProg3 uses an ADC to measure the onboard target voltage. Before the ADC input, there is a voltage divider to bring the target voltage within the dynamic range.

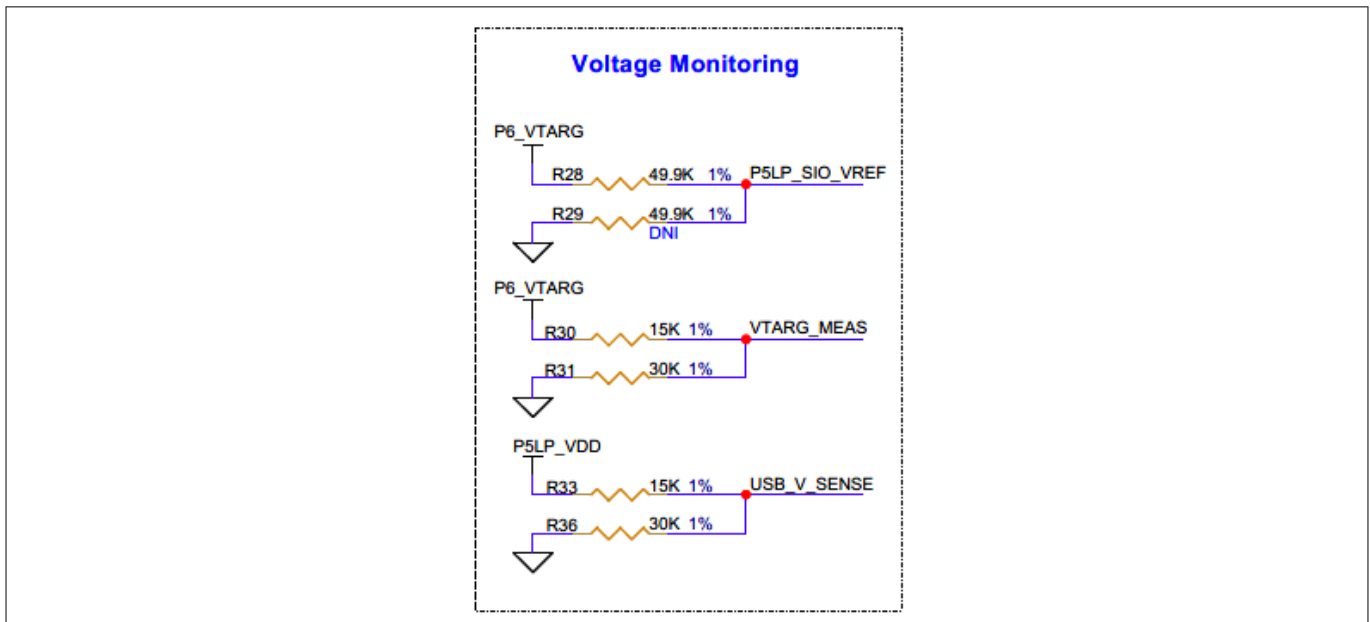

Figure 19 Schematic of KitProg3 onboard target voltage monitoring circuit

This feature allows you to measure the target MCU voltage through KitProg3 using PSOC™ or ModusToolbox™ programmer tools.

3 Hardware

3.2.2.4 KitProg3 programming mode selection button and status LED

There is a mode selection button (SW3) connected to the P1[2] pin of the PSOC™ 5LP device for programming mode selection. This button can be used to switch between Bulk and HID modes (see the [KitProg3 user guide](#) for details). The button works in an active LOW configuration and is shorted to GND when pressed.

PSOC™ 5LP has a status LED (D12, red) connected to its P1[4] pin of the PSOC™ 5LP device, which indicates the programming status. See the following table for a summary of the LED status:

Table 5 KitProg3 mode switching

KitProg3 programming modes	Status LED (D2)
CMSIS-DAP/Bulk mode (default)	ON
CMSIS-DAP/HID mode	RAMPING at 1 Hz

Note: Switching between the programming modes can be done through the [Firmware-loader tool](#). For details, see Section Mode Switching in the [KitProg3 user guide](#).

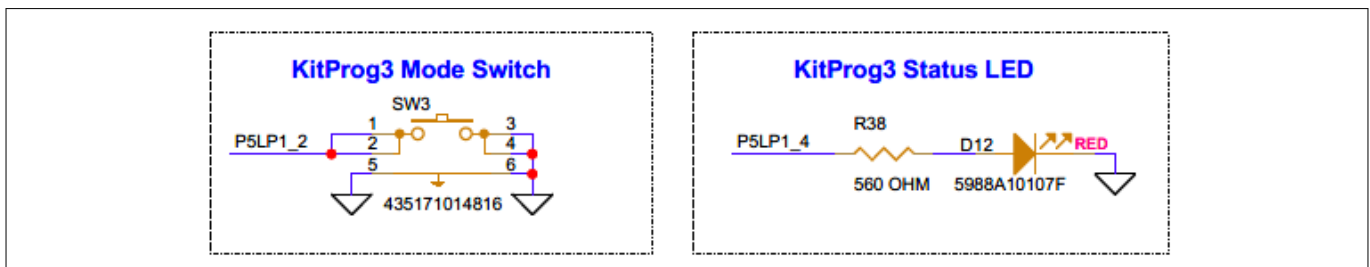

Figure 20 Schematic of KitProg3 mode selection button (SW3) and status LED (D12)

3.2.3 PSOC™ 6 MCU features

PSOC™ 6 MCU is a high-performance, ultra-low-power, and secured MCU platform, purpose-built for IoT applications. The CY8C62x8/A product line, based on the PSOC™ 6 MCU platform, is a combination of a dual-CPU microcontroller with low-power flash technology, digital programmable logic, high-performance analog-to-digital conversion, and standard communication and timing peripherals.

PSOC™ 6 MCU has the following features:

- **Dual CPU subsystem:** efficient parallel processing with a 150 MHz Arm® Cortex®-M4F and a 100-MHz Cortex-M0+ CPU
- **Memory subsystem:** large memory capacity with 2048 KB application flash, 32 KB auxiliary flash, 32 KB supervisory flash, and 1024 KB SRAM
- **Low-power operation:** operates at 1.7 V to 3.6 V with a Deep Sleep mode current of 7 µA, conserving power for battery-powered applications
- **Flexible clocking options:** offers a range of clocking options for efficient timing control
- **Quad-SPI (QSPI)/Serial Memory Interface (SMIF):** Supports high-speed data access and processing with XIP, encryption/decryption, and a 4 KB cache
- **Serial communication:** features configurable SCBs, USB full-speed device interface, and SD Host Controller/eMMC/SD controllers for efficient data transfer and communication
- **Programmable analog:** includes a 12-bit 2-Msps SAR ADC for analog processing and low-power comparators for the system's Deep Sleep and Hibernate modes
- **Programmable GPIOs:** offers 102 programmable GPIOs with smart I/O ports for Boolean operations and customizable drive modes, strengths, and slew rates

3 Hardware

PSOC™ 6 MCU offers several key features that enable it to run the machine learning algorithms efficiently. These include a dual CPU subsystem for parallel processing, a large memory capacity for storing and processing datasets, low-power operation for battery-powered applications, flexible clocking options for timing control, high-speed data access and communication, analog processing capabilities, and programmable GPIOs for hardware control. For more details, see the [PSOC™ 6 MCU datasheet](#).

In addition, Infineon's broad portfolio of hardware, software, and tool solutions, combined with DEEPCRAFT™'s expertise in developing robust machine learning solutions for edge devices, making it easier to leverage the advanced opportunities from AI/ML. DEEPCRAFT™ Studio, an end-to-end development platform, is planned for ML model creation, training, and deployment. This platform will enable you to bring AI into various embedded applications, enhancing functionalities, control, energy efficiency, and privacy. With DEEPCRAFT™ AI, you can benefit from a faster time to market, serving a wide range of applications for global customers.

3.2.3.1 PSOC™ 6 MCU power supply

PSOC™ 6 MCU is designed to operate at low power, making it suitable for battery-powered applications. The powering section of the board includes the core and IO domain power connections, decoupling capacitors, and ferrite beads to isolate the digital and analog domains.

The core and IO domain power connections are designed to provide a stable and efficient power supply to the PSOC™ 6 MCU. The core power supply is connected to the VCC_3V3 rail, while the IO power supply is connected to both the VCC_3V3 and VCC_1V8 power rails. These power rails are designed to provide the required voltage levels for the core and IO operations.

Table 6 PSOC™ 6 MCU power rail details

PSOC™ 6 MCU power rail	Supply voltage rail
VDDD	VCC_3V3 (3.3 V)
VDDA, VDDIOA	VCC_3V3 (3.3 V)
VDDUSB	VCC_3V3 (3.3 V)
VBACKUP	VCC_3V3 (3.3 V)
VDDIO0	VCC_1V8 (1.8 V)
VDDIO1	VCC_3V3 (3.3 V)
VDDIO2	VCC_1V8 (1.8 V)
VDD_NS	VCC_3V3 (3.3 V)
VCCD	1.1 V/0.9 V (internal LDO or Buck)

3 Hardware

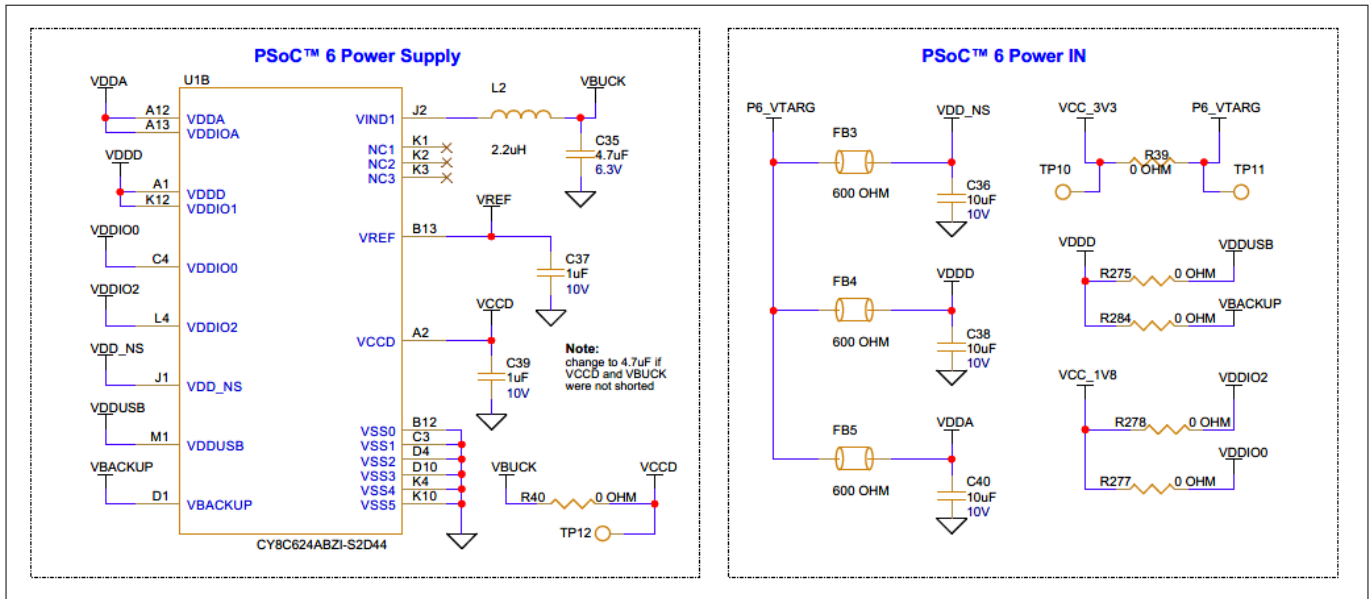

Figure 21 Schematic for PSoC™ 6 MCU power rail connections

Note: R40 resistor is populated to enable the connection between the VCCD and VBUCK power supplies to bypass the internal LDO and connect the VBUCK supply to the VCCD. For using internal LDO for VCCD, remove the R40.

Ferrite beads are used to isolate the digital and analog domains, preventing interference between these two domains. They are placed on the power lines connecting the digital and analog domains, ensuring that the power supply remains stable and free from interference.

Decoupling capacitors are placed close to the power pins of the MCU to filter out high-frequency noise and prevent it from affecting the operation of the MCU. These capacitors maintain a stable power supply and improve the system's performance.

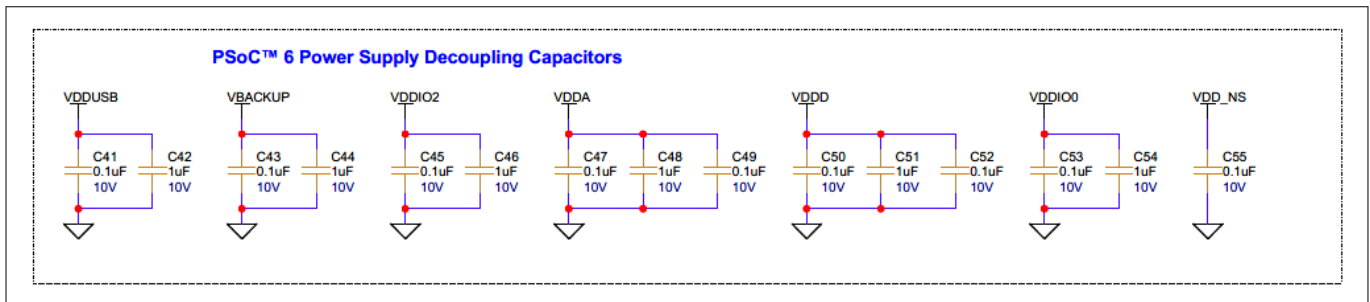

Figure 22 Schematic for decoupling capacitors of PSoC™ 6 MCU power rails

3.2.3.2 PSoC™ 6 MCU IO signals

Configurable IO ports of the PSoC™ 6 MCU for easy interfacing with peripherals and sensors. The PSoC™ 6 MCU features a comprehensive set of IO ports designed to facilitate easy interfacing with various sensors and peripherals. PSoC™ 6 MCU has **15 IO ports**, each of which can be configured with different functions based on the application requirements (refer to the [datasheet](#) for the list of alternate functions supported by the IOs of each port). Each IO port of the PSoC™ 6 MCU is associated with a dedicated power supply, enabling users to configure different IO ports at different logic levels.

3 Hardware

Table 7 PSOC™ 6 MCU IO ports and associated power rails

PSOC™ 6 MCU IO ports	PSOC™ 6 MCU power rail	Logic level
P0	VBACKUP (VCC_3V3)	3.3 V
P1	VDDD (VCC_3V3)	3.3 V
P2, P3, P4	VDDIO2 (VCC_1V8)	1.8 V
P5, P6, P7, P8	VDDIO1 (VCC_3V3)	3.3 V
P9, P10	VDDIOA, VDDA (VCC_3V3)	3.3 V
P11, P12, P13	VDDIO0 (VCC_1V8)	1.8 V
P14	VDDUSB (VCC_3V3)	3.3 V

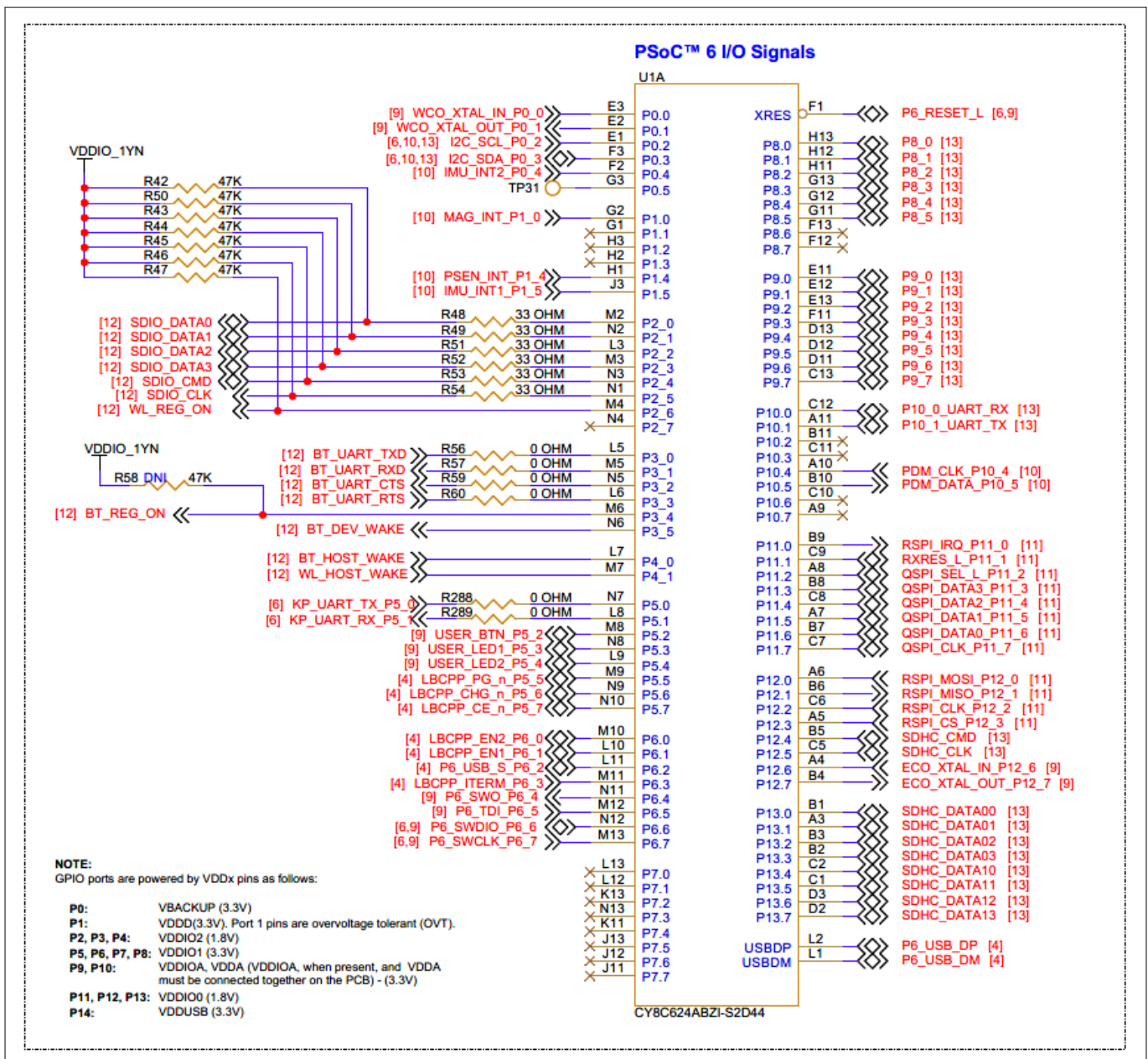

Figure 23 Schematic of PSOC™ 6 MCU IO signals

3 Hardware

3.2.3.3 PSOC™ 6 MCU clock sources

The PSOC™ 6 AI Evaluation Kit is designed to support advanced applications with its hardware features. It includes a **24 MHz** crystal (Y2) connected to **P12[6]** and **P12[7]**. A **32.768 KHz** crystal (Y1) is connected to **P0[0]**, **P0[1]** to enable the ECO (External Crystal Oscillator) and WCO (Watch Crystal Oscillator) modes of the PSOC™ 6 MCU.

The ECO mode is used for high-performance clock generation, which is crucial for applications that require fast processing speeds. The WCO mode, on the other hand, is used for low-power operation, allowing the device to run at reduced power consumption while still maintaining accurate timekeeping.

For USB functionality, it is recommended to use an external clock source for precise clock generation. This is because USB communication requires a stable and precise clock signal to ensure reliable data transfer. The external clock source can be connected to the PSOC™ 6 MCU's USB clock input, providing the necessary clock signal for USB operation.

By utilizing these features, the PSOC™ 6 AI Evaluation Kit provides high-performance clock generation, low-power operation, and reliable USB communication, making it suitable for advanced applications.

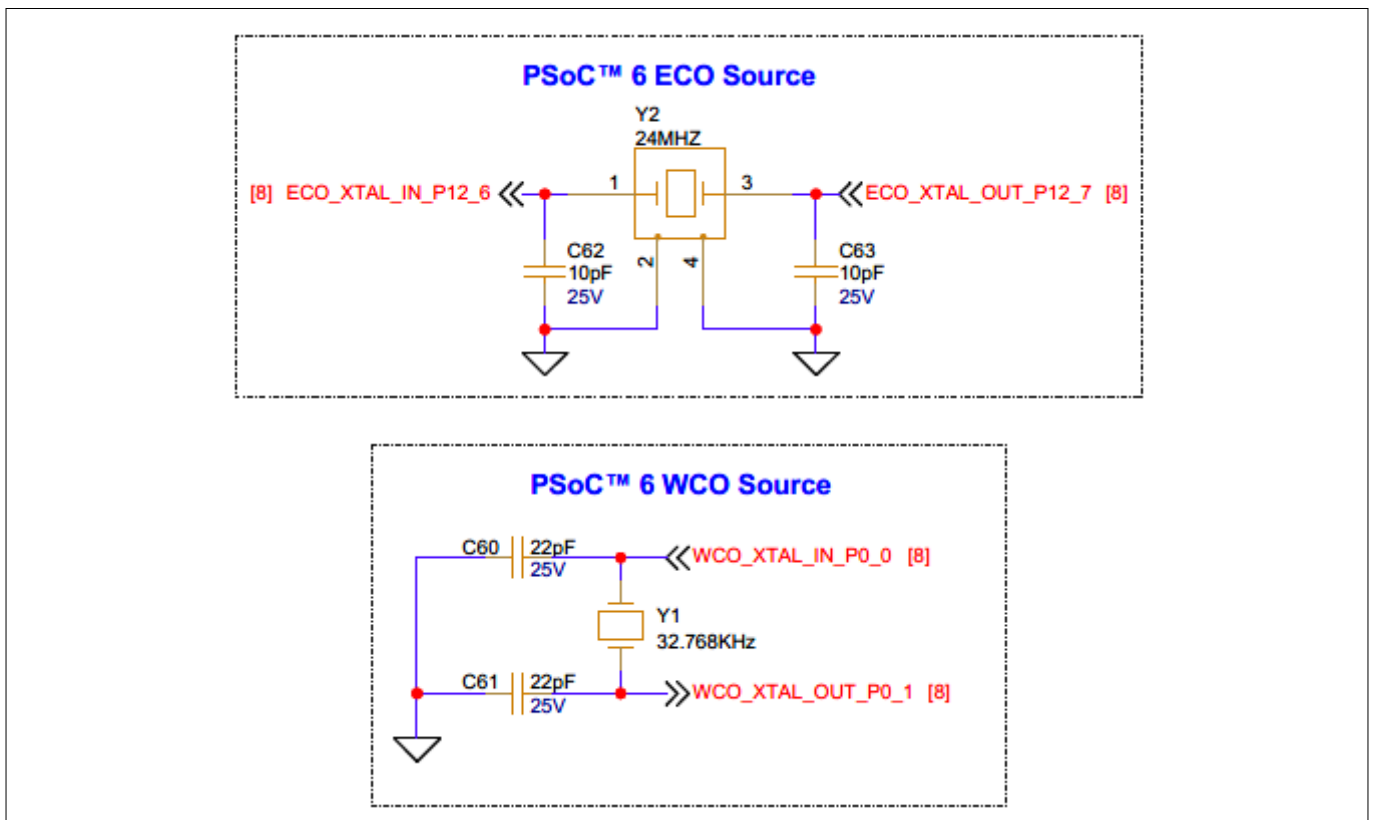

Figure 24 Schematic of clock sources for ECO and WCO of PSOC™ 6 MCU

3.2.3.4 PSOC™ 6 device external programming/debugging header

In the PSOC™ 6 AI Evaluation Board, a default programming/debugging interface is through the onboard KitProg3 programmer/debugger. In addition, you can use an external programmer like MiniProg4 to program/debug PSOC™ 6 device through this 10-pin header (J4).

3 Hardware

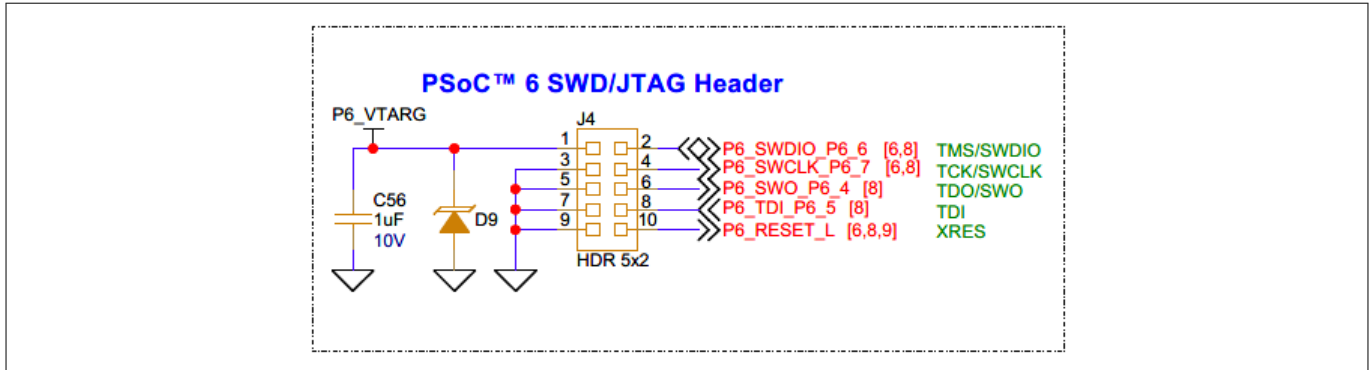

Figure 25 PSOC™ 6 SWD/JTAG header interface schematic

The interface circuit D9 provides ESD protection, and C56 provides filtered reference voltage for external programmer to detect the target voltage of the PSOC™ 6 device.

Note: Do not feed power to the board through this header. The **J4.1** needs to be used only for taking the target voltage reference.

3.2.3.5 PSOC™ 6 USB device

The PSOC™ 6 AI Evaluation Kit consists of a device Type-C USB (**J2**) for the PSOC™ 6 MCU, which can also be used as a power source for the board, as mentioned in section *Power inputs and overvoltage protection*. The device USB lines are connected to the PSOC™ 6 MCU through an ESD protection (**U9**).

Table 8 PSOC™ 6 USB device interface pin assignments

Signal name	PSOC™ 6 MCU IO
P6_USB_DP	USBDP
P6_USB_DM	USBDM

3 Hardware

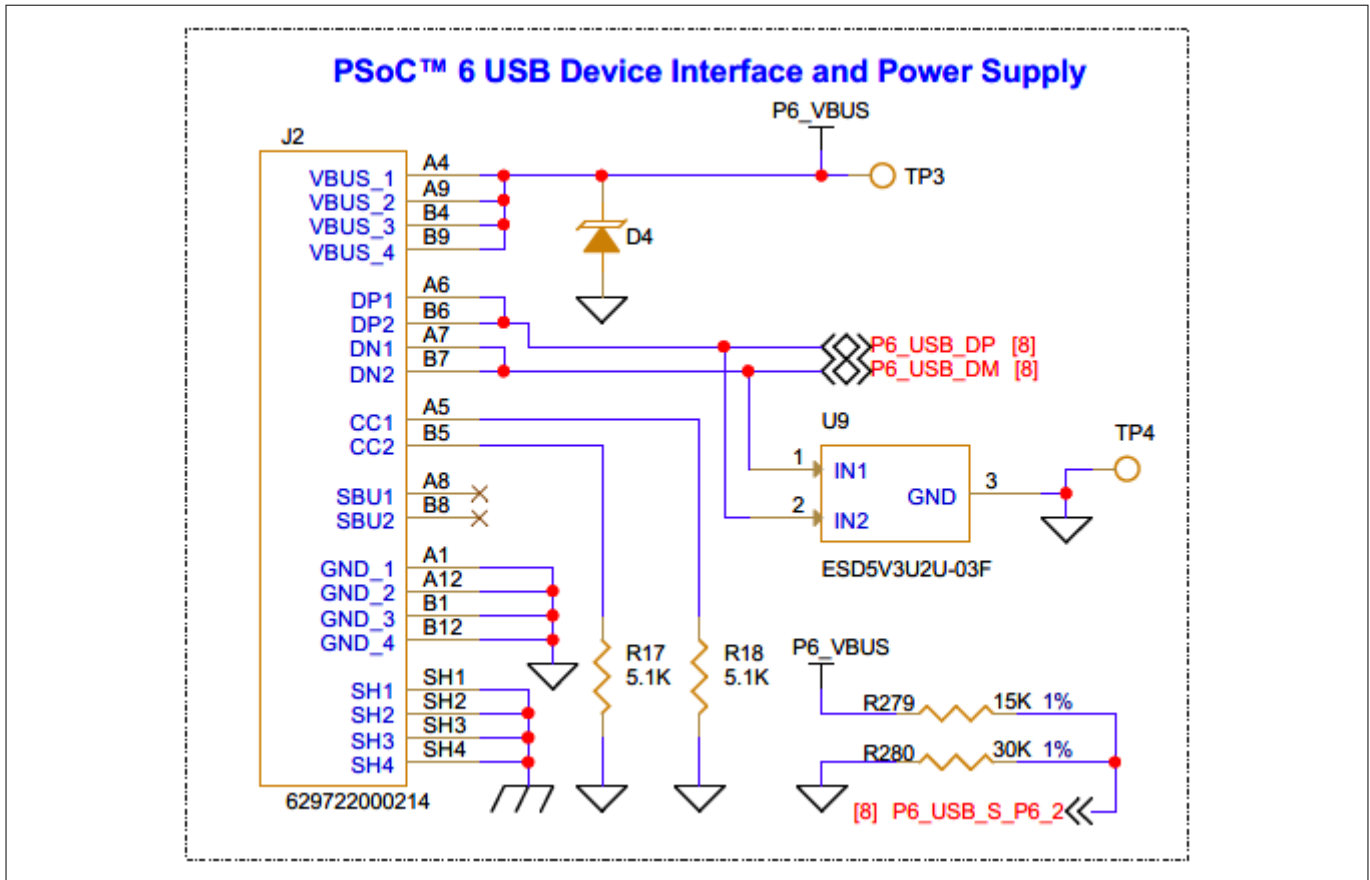

Figure 26 Schematic for PSOC™ 6 USB device interface and power supply

3.2.4 User LEDs and power LED

The kit contains two discrete user LEDs: **D2**, **D3** (red), and a power LED **D1** (red) for indication. The power LED (**D1**) indicates that the board is powered from either the onboard KitProg3 Type-C USB connector (**J1**), device Type-C USB connector (**J2**), or battery connector (**J3**).

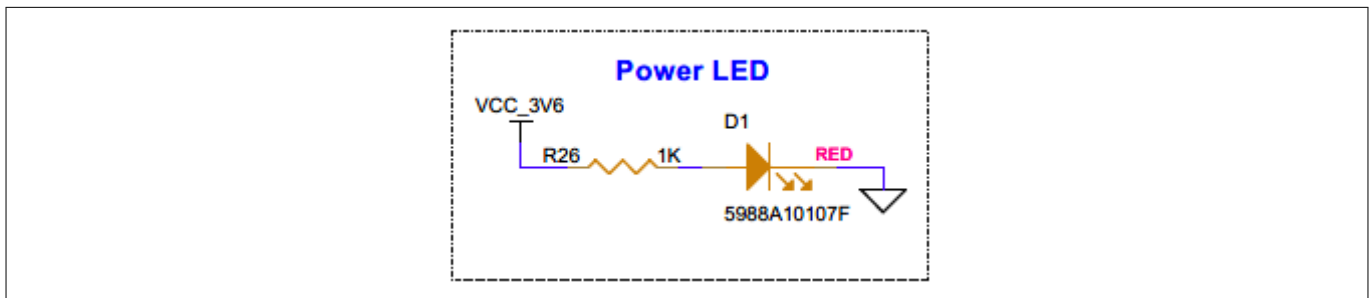

Figure 27 Schematic for power LED

The user LEDs (**D2** and **D3**) are connected to P5[3] and P5[4] GPIOs of the PSOC™ 6 MCU, respectively. The user LEDs are active HIGH, so the pins must be driven HIGH to turn ON the LEDs.

Table 9 Pin assignments for user LEDs

Signal name	PSOC™ 6 I/O	Logic level
USER_LED1_P5_3	P5[3]	3.3 V
USER_LED2_P5_4	P5[4]	3.3 V

3 Hardware

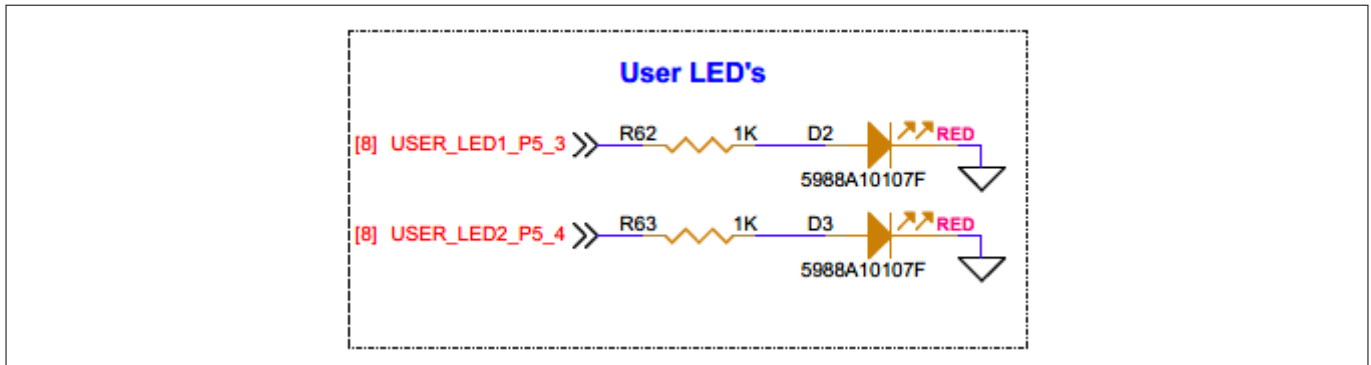

Figure 28 Schematic of user LEDs

3.2.5 Reset and user buttons

The board contains one reset button (**SW1**) for resetting the PSOC™ 6 MCU. When this SW1 button is pressed, the **P6_RESET_L** line of the PSOC™ 6 MCU is pulled to the ground, which in turn resets the target device. The pull-up resistor on the **P6_RESET_L** is populated on the kit.

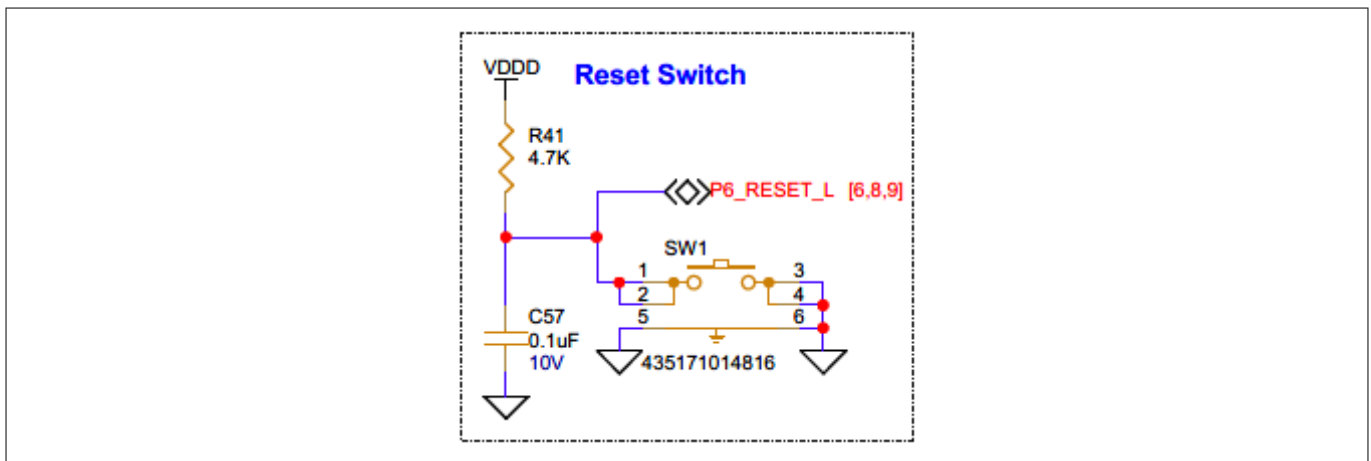

Figure 29 Schematic for Reset button interface

The board features a user button SW2, which serves as a general user input or for controlling different application states. The PSOC™ 6 MCU pin connected to user button SW2 is pulled to the ground through a **1K** resistor when this button is pressed.

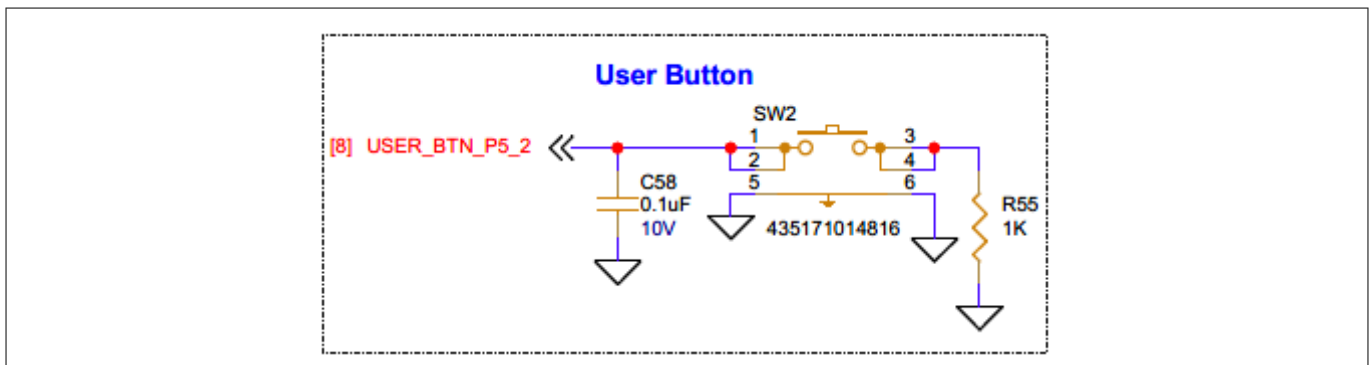

Figure 30 Schematic for User button interface

3 Hardware

3.2.6 XENSIV™ digital barometric pressure sensor

The PSOC™ 6 AI Evaluation Kit contains Infineon's digital barometric pressure sensor (U3) **DPS368XTSA1**. The sensor uses an I2C interface to communicate, along with an interrupt signal, **PSEN_INT_P1_4**. The default I2C secondary address is **0x77**. To change the address to **0x76**, populate **R66**.

Table 10 Pin assignment for digital XENSIV™ barometric pressure sensor interface signals

Signal name	PSOC™ 6 I/O	Logic level
I2C_SDA_P0_3	P0[3]	3.3 V
I2C_SCL_P0_2	P0[2]	3.3 V
PSEN_INT_P1_4	P1[4]	3.3 V

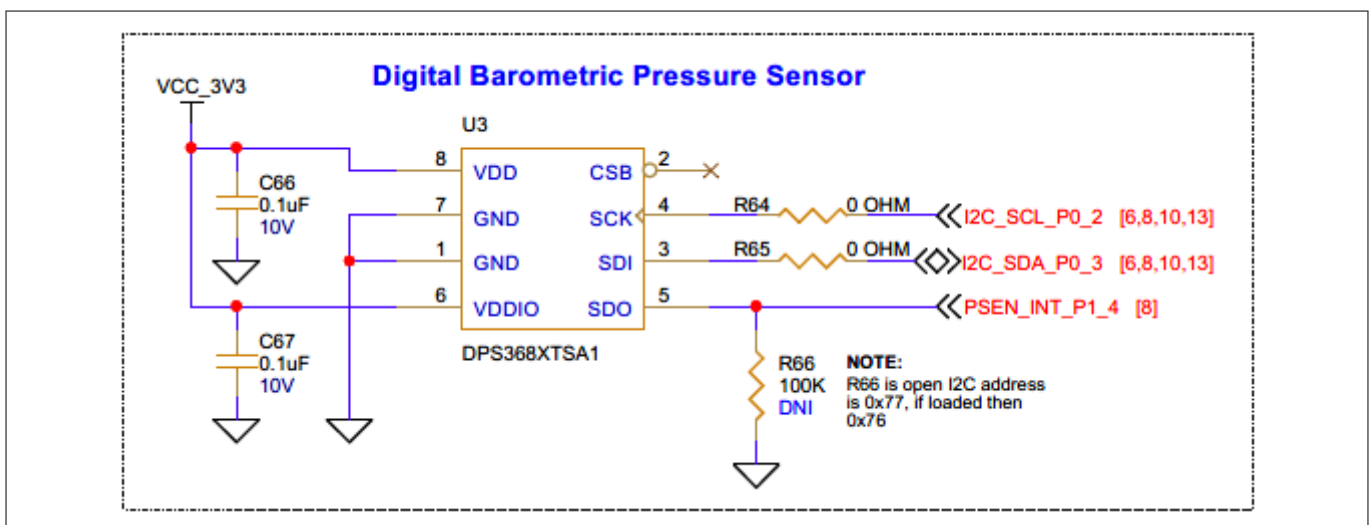

Figure 31 Schematic of digital XENSIV™ barometric pressure sensor interface

3.2.7 XENSIV™ MEMS digital microphones

The PSOC™ 6 AI Evaluation Kit contains Infineon's two digital PDM MEMS microphones (**U4**, **U5**) **IM72D128V01XTMA1** which share the same PDM bus.

Each PDM microphone has a SELECT pin. If this pin is connected to GND, the PDM data is available on the falling edge of the PDM clock. If this pin is connected to VDD, the PDM data is available on the rising edge of the PDM clock.

The left PDM microphone (**U4**) data is available on the falling edge of the PDM_CLK, as the SELECT pin is tied to GND. The right PDM microphone (**U5**) data is available on the rising edge of the PDM_CLK, as the SELECT pin is tied to VCC_3V3. The microphones are placed ~27 mm apart and are supplied from a 3.3 V (VCC_3V3) rail.

Table 11 Pin assignment of microphones PDM interface

Signal name	PSOC™ 6 I/O	Logic level
PDM_CLK	P10[4]	3.3 V
PDM_DATA	P10[5]	3.3 V

3 Hardware

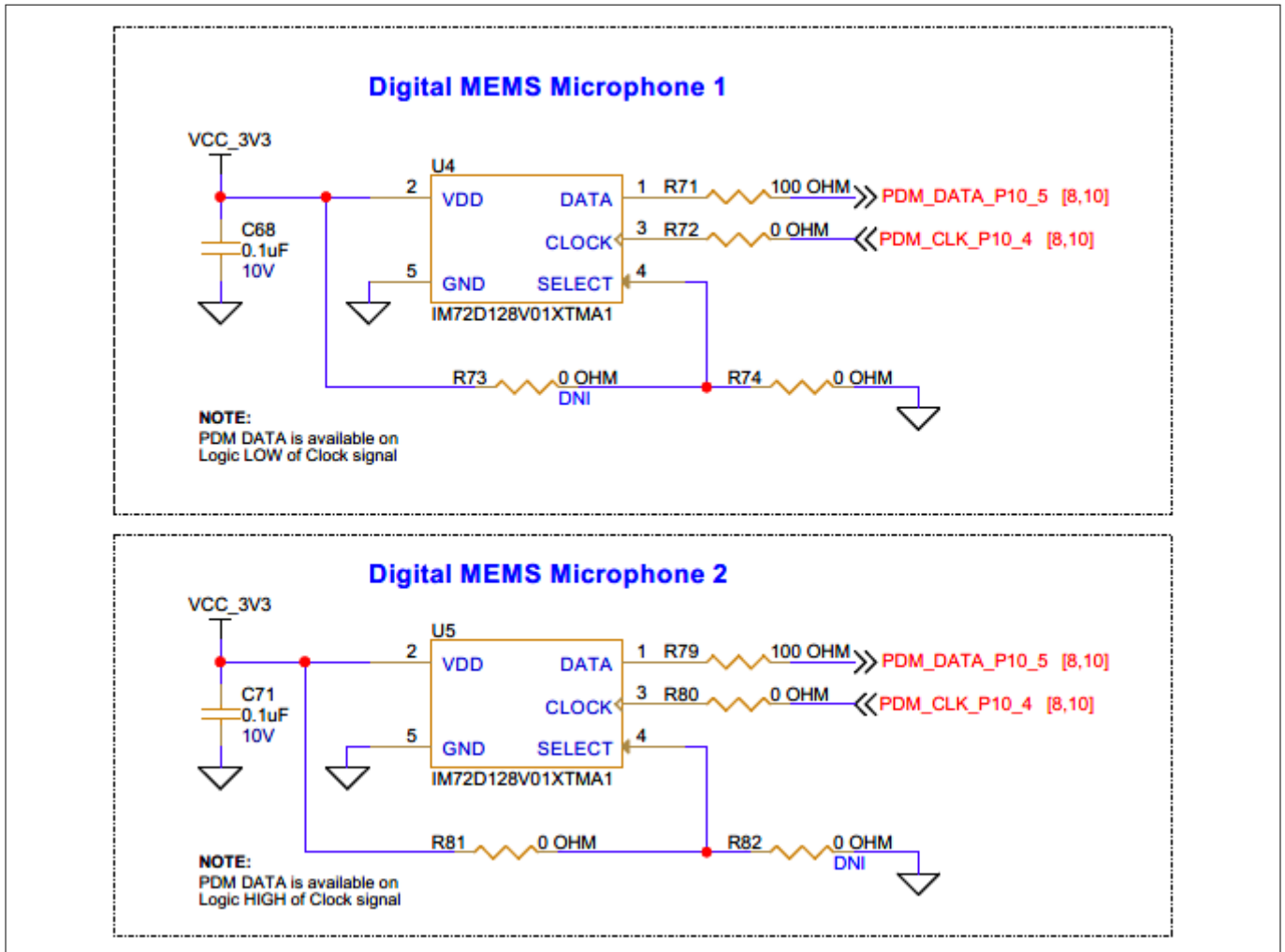

Figure 32 Schematic of digital microphones interface

3.2.8 XENSIV™ 60 GHz RADAR sensor

The PSOC™ 6 AI Evaluation Kit contains Infineon's XENSIV™ 60 GHz RADAR sensor (U6) BGT60TR13CE6327XUMA1. The BGT60TR13C MMIC is a 60 GHz radar sensor with integrated antennas; one transmitting and three receiving antennas. The sensor incorporates an L-shaped antenna array, ensuring both horizontal and vertical angular measurements. This sensor comes with an Antennas in Package (AIP) concept, which eliminates the antenna design complexity at the user end, and the PCB can be designed with standard FR4 materials. For more details, see the [RADAR sensor webpage](#). The RADAR sensor uses an SPI interface to communicate, along with an interrupt signal (RSPI_IRQ_P11_0) and reset signal (RXRES_L_P11_1).

Table 12 Pin assignment details for RADAR sensor interface

Signal name	PSOC™ 6 IO	Logic level
RSPI_CS_P12_3	P12[3]	1.8 V
RSPI_CLK_P12_2	P12[2]	1.8 V
RSPI_MOSI_P12_0	P12[0]	1.8 V
RSPI_MISO_P12_1	P12[1]	1.8 V
RSPI_IRQ_P11_0	P11[0]	1.8 V
RXRES_L_P11_1	P11[1]	1.8 V

3 Hardware

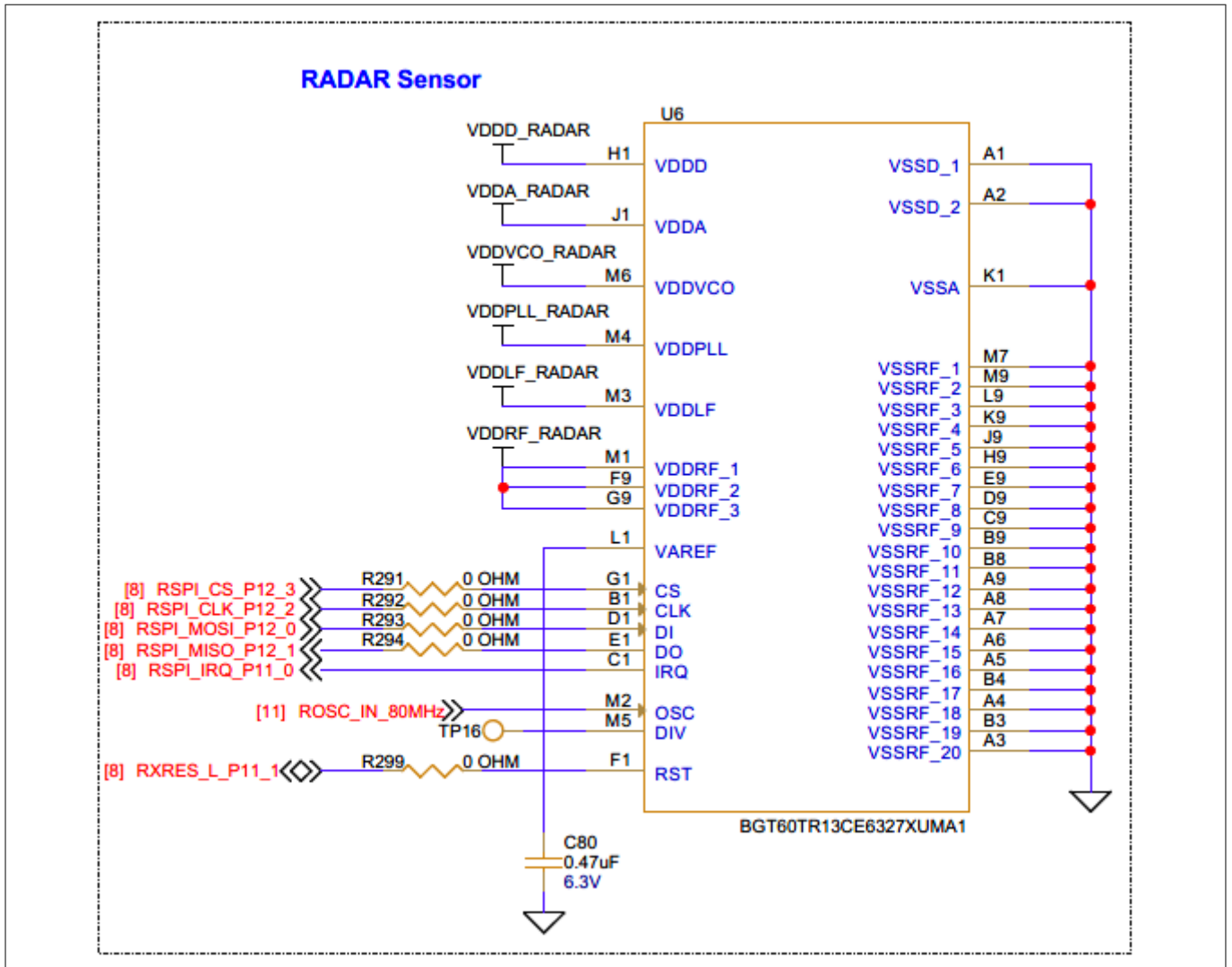

Figure 33 Schematic of RADAR sensor interface

The RADAR sensor uses power supply filters, including ferrite beads and various capacitors, as shown in the following figure.

3 Hardware

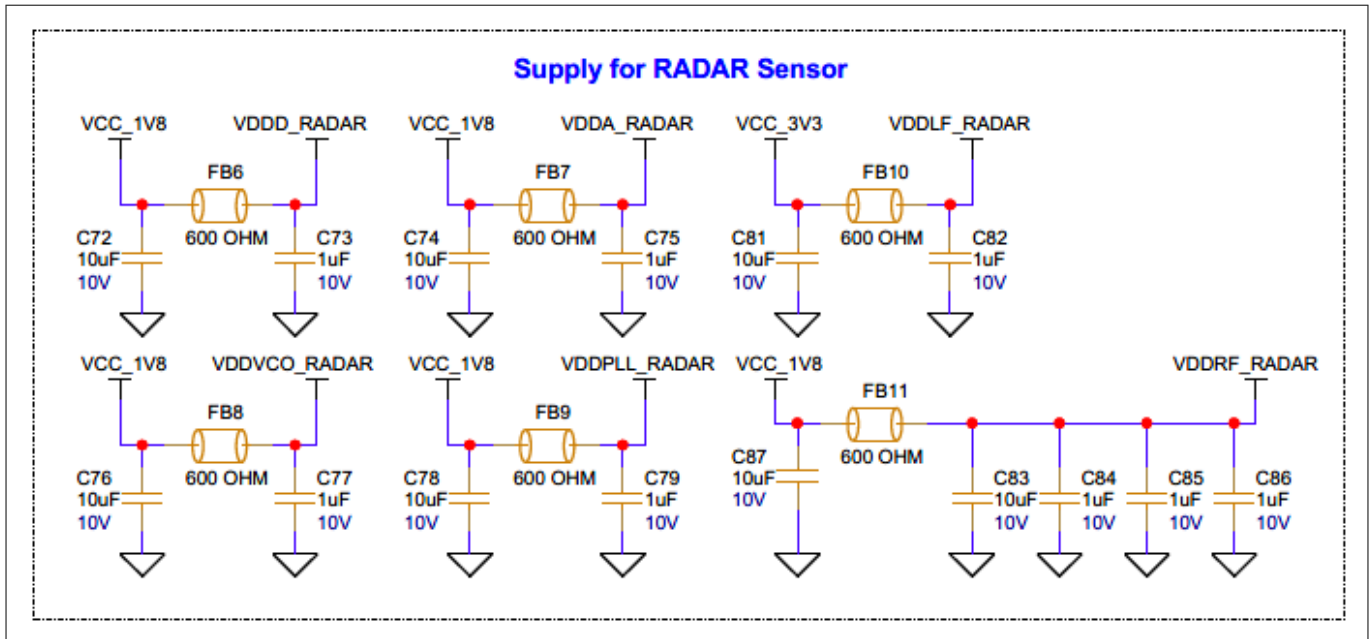

Figure 34 Schematic RADAR sensor power supply filtering

The following figure shows how an onboard crystal oscillator (U15) feeds 80 MHz clock input to the RADAR sensor.

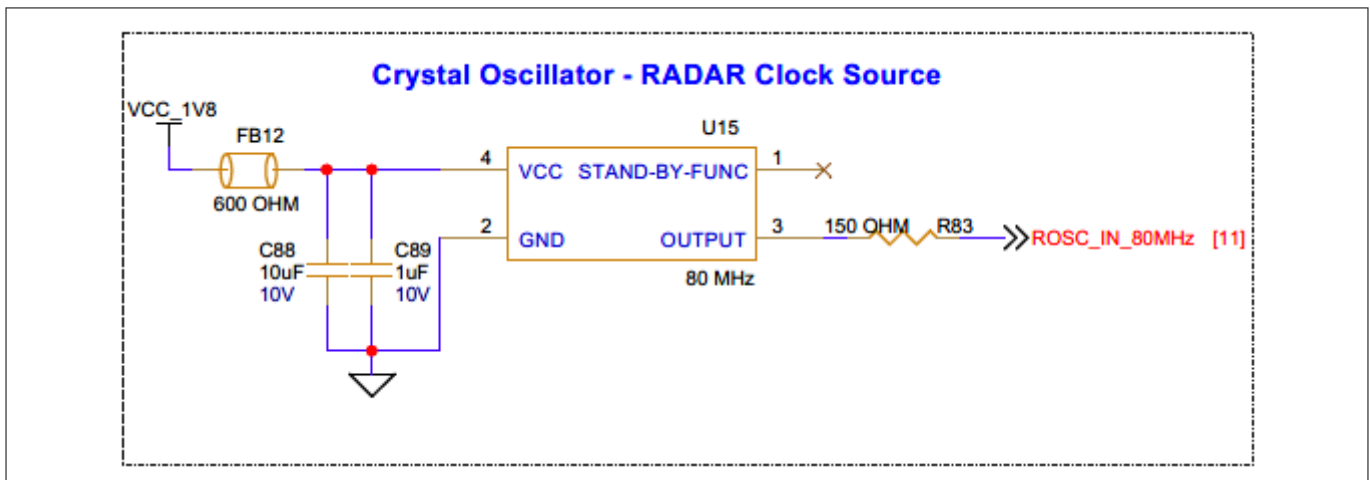

Figure 35 Schematic of crystal oscillator for RADAR sensor clock input

3.2.9 6-axis IMU (accelerometer + gyroscope)

6-axis IMU (accelerometer + gyroscope) for acceleration and gyroscopic angular rate sensing in each spatial direction.

This kit contains a 6-axis motion sensor (U18), also known as the inertial measurement unit (IMU), which provides precise 3-axis acceleration and 3-axis gyroscopic angular rate data in each spatial direction. The sensor uses an I2C interface to communicate, along with two interrupt signals, which are connected to the INT1 and INT2 pins of the sensor to the PSOC™ 6 MCU by default. The default I2C secondary address is 0x68 (also configurable to 0x69 by removing R287 and populating R286).

3 Hardware

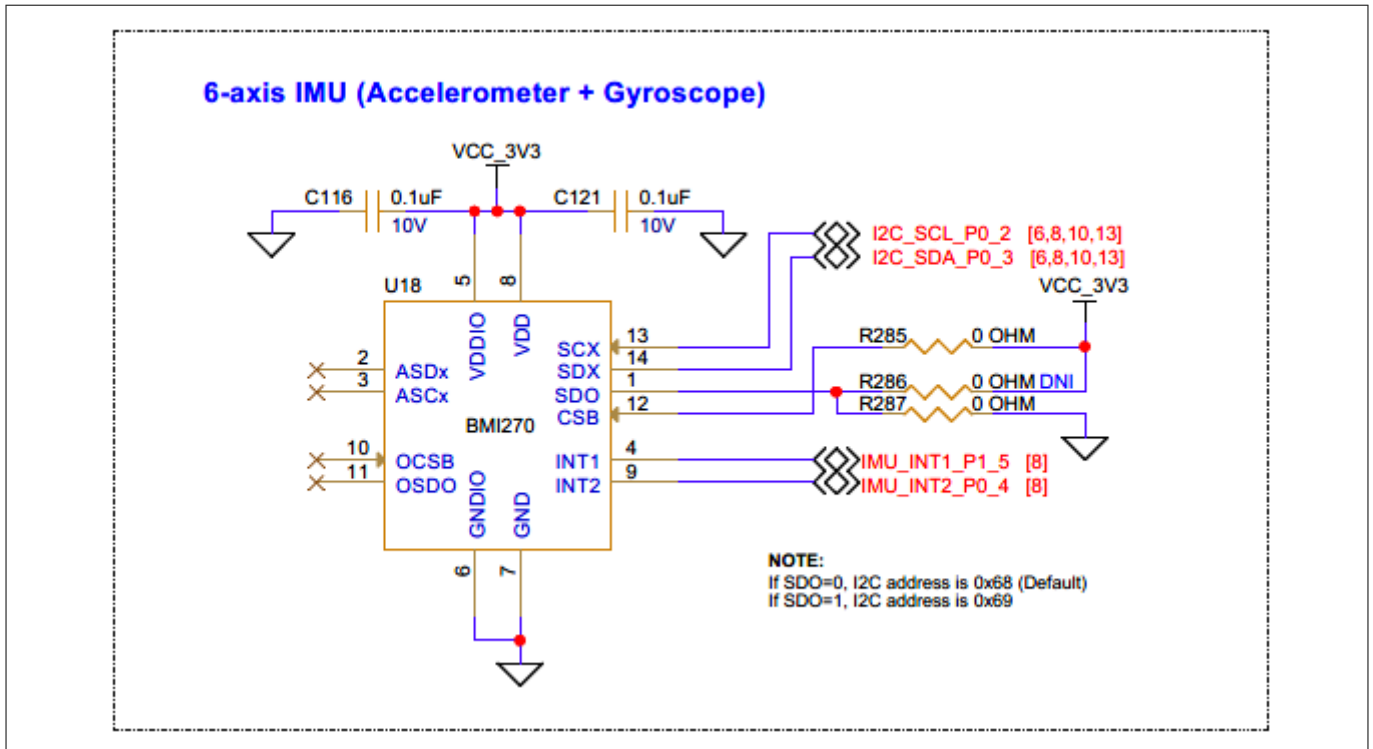

Figure 36 Schematic of 6-axis IMU (accelerometer + gyroscope)

3.2.10 3-axis magnetometer

3-axis magnetometer for geomagnetic field direction and strength sensing

This kit contains a 3-axis magnetometer sensor (U19), which is for sensing the direction and strength of the geomagnetic field. The sensor uses an I2C interface to communicate, along with an interrupt signal MAG_INT_P1_0. The default I2C secondary address is 0x15.

Table 13 Pin assignment for 3-axis magnetometer interface signals

Signal name	PSOC™ 6 I/O	Logic level
I2C_SDA_P0_3	P0[3]	3.3 V
I2C_SCL_P0_2	P0[2]	3.3 V
MAG_INT_P1_0	P1[0]	3.3 V

3 Hardware

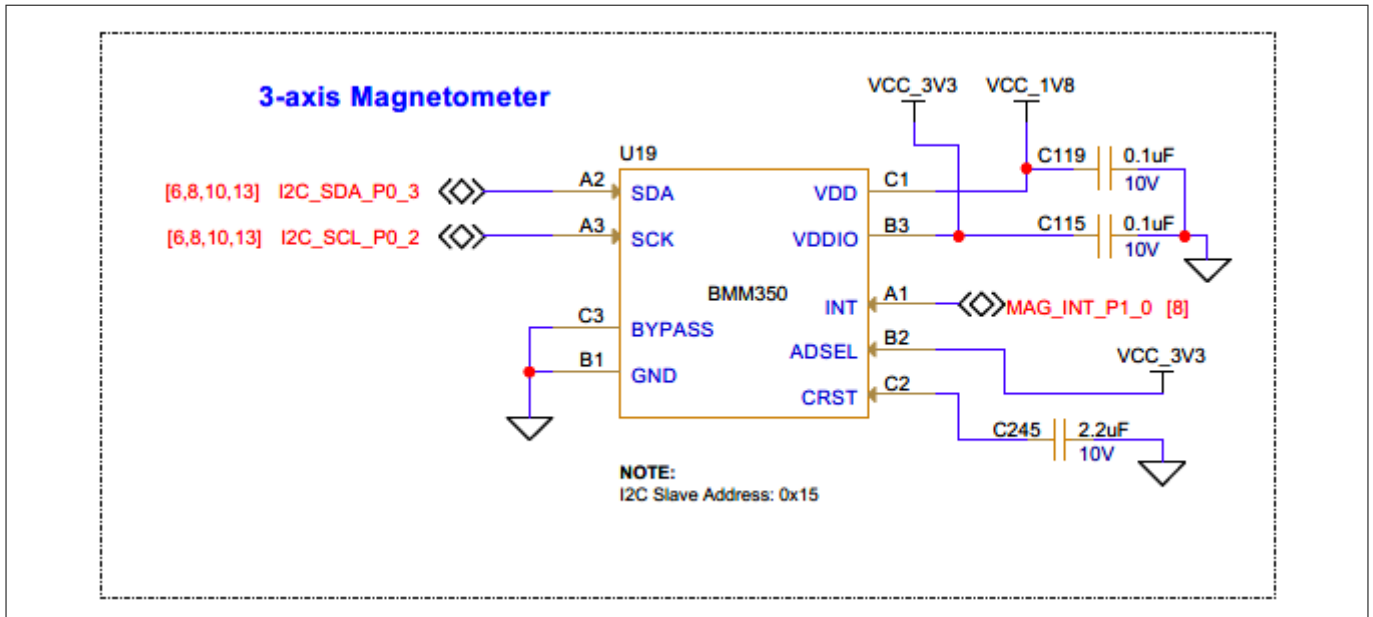

Figure 37 Schematic of a 3-axis magnetometer

3.2.11 QSPI flash memory

PSOC™ 6 AI Evaluation Kit has Infineon's onboard Quad SPI NOR flash memory **S25HS512TFANHI010 (U7)** of 512 Mb. The NOR flash is connected to the Quad SPI interface of the PSOC™ 6 MCU. The NOR flash device supports 4-bit (Quad I/O) serial commands. The NOR flash device can be used for both data and code memory with execute-in-place (XIP) support and encryption.

Table 14 Pin assignments of QSPI flash memory interface

Signal name	PSOC™ 6 IO	Logic level
QSPI_DATA0_P11_6	P11[6]	1.8 V
QSPI_DATA1_P11_5	P11[5]	1.8 V
QSPI_DATA2_P11_4	P11[4]	1.8 V
QSPI_DATA3_P11_3	P11[3]	1.8 V
QSPI_CLK_P11_7	P11[7]	1.8 V
QSPI_SEL_L_P11_2	P11[2]	1.8 V

3 Hardware

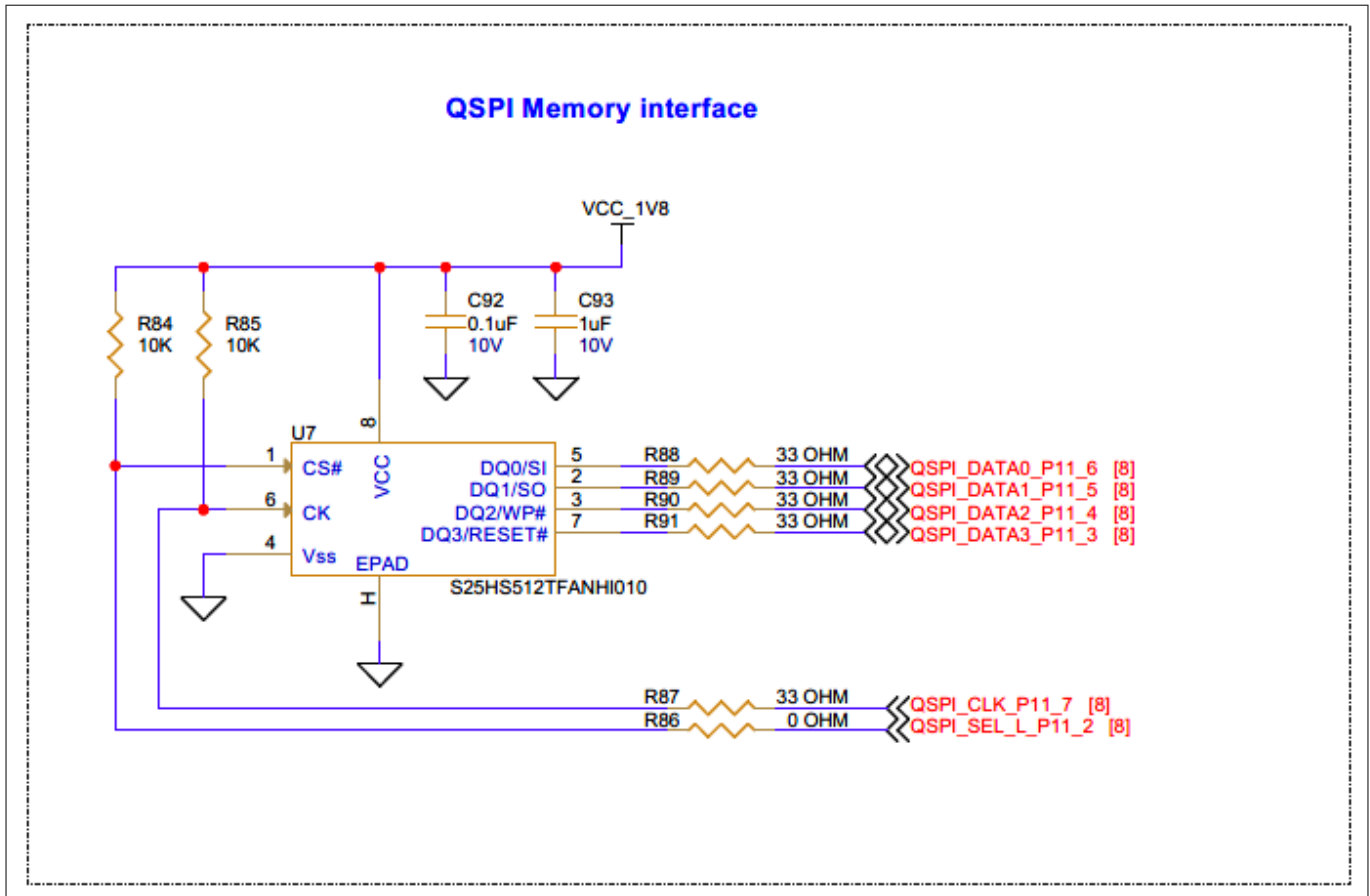

Figure 38 Schematic of QSPI flash memory interface

3.2.12 Wi-Fi + Bluetooth® module interface

The LBEE5KL1YN-814 SiP (system-in-package) module (1YN module), powered by the Infineon CYW43439 chipset, is a dual-mode wireless solution that offers 802.11b/g/n Wi-Fi and Bluetooth® 5.2 capabilities. This module is designed for easy integration into various applications, providing reliable and high-speed wireless connectivity.

The 1YN module is powered with an external VBAT supply voltage of 3.6 V and an IO's supply voltage of 1.8 V for interface IOs.

3 Hardware

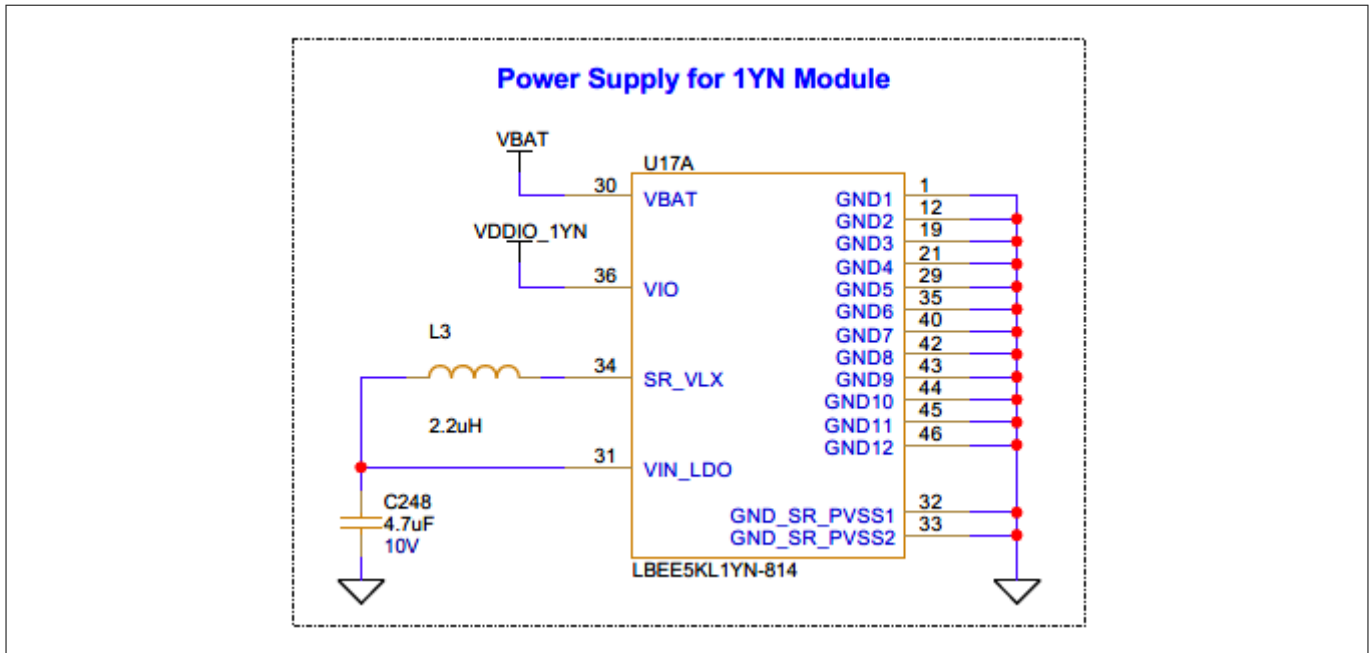

Figure 39 1YN module power supply schematic

PSOC™ 6 device communicates to 1YN module using a standard SDIO interface for WLAN and UART interface for Bluetooth® operation. PSOC™ 6 device interface with 1YN module supports the following features.

Table 15 PSOC™ 6 and 1YN module interface details

1YN module signal	PSOC™ 6 device Pin	Description
BT_REG_ON	P3[4]	BT_REG_ON signal controlled by PSOC™ 6 device IO used to power up or power down the internal regulators used by the Bluetooth® section. Also, when deasserted, this pin holds the Bluetooth® section in reset. This pin has an internal 200 kΩ pull-down resistor that is enabled by default. It can be disabled through programming.
WL_REG_ON	P2[6]	WL_REG_ON signal controlled by PSOC™ 6 device IO used to power up or power down the internal regulators used by the WLAN section. Also, when deasserted, this pin holds the WLAN section in reset. This pin has an internal 200 kΩ pull-down resistor that is enabled by default. It can be disabled through programming.
WL_HOST_WAKE	P4[1]	Wi-Fi HOST_WAKE or general-purpose I/O signal
BT_HOST_WAKE	P4[0]	Bluetooth® HOST_WAKE or general-purpose I/O signal
BT_DEV_WAKE	P3[5]	DEV_WAKE or general-purpose I/O signal
SDIO_CLK	P2[5]	SDIO clock input
SDIO_CMD	P2[4]	SDIO command line
SDIO_DATA[0:3]	P2[0:3]	SDIO Data lines

(table continues...)

3 Hardware

Table 15 (continued) PSOC™ 6 and 1YN module interface details

1YN module signal	PSOC™ 6 device Pin	Description
BT_UART_TXD	P3[0]	UART serial output. Serial data output for the HCI UART interface.
BT_UART_RXD	P3[1]	UART serial input. Serial data input for the HCI UART interface.
BT_UART_CTS	P3[2]	UART clear-to-send. Active-low clear-to-send signal for the HCI UART interface.
BT_UART_RTS	P3[3]	UART request-to-send. Active-low request to send signal for the HCI UART interface.

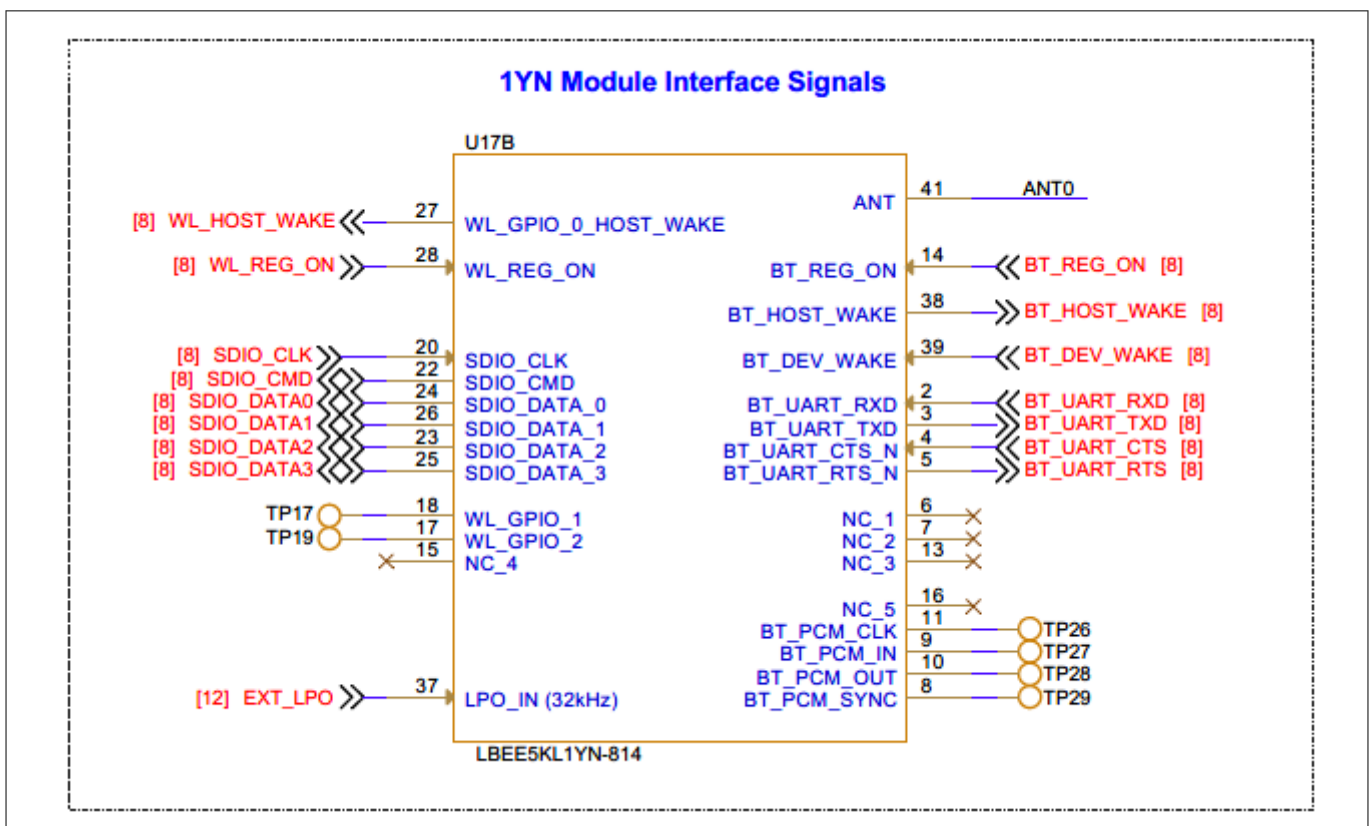

Figure 40 1YN module interface schematic

An onboard oscillator (Y3) of 32.768 KHz is used to provide external sleep clock input (LPO_IN) to the 1YN module.

3 Hardware

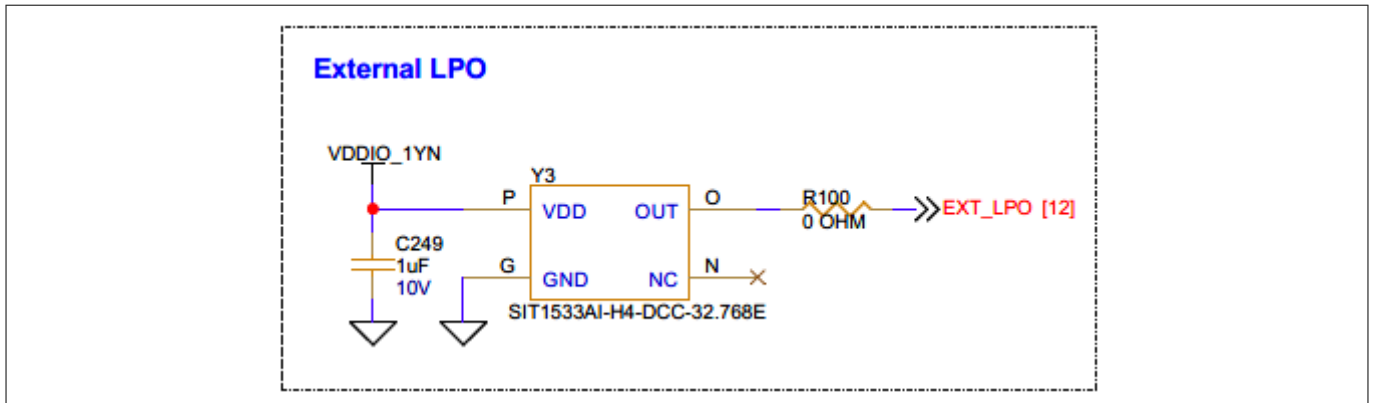

Figure 41 External LPO schematic

1YN module antenna output is connected to an onboard chip antenna with a matching circuit, as shown in the following figure.

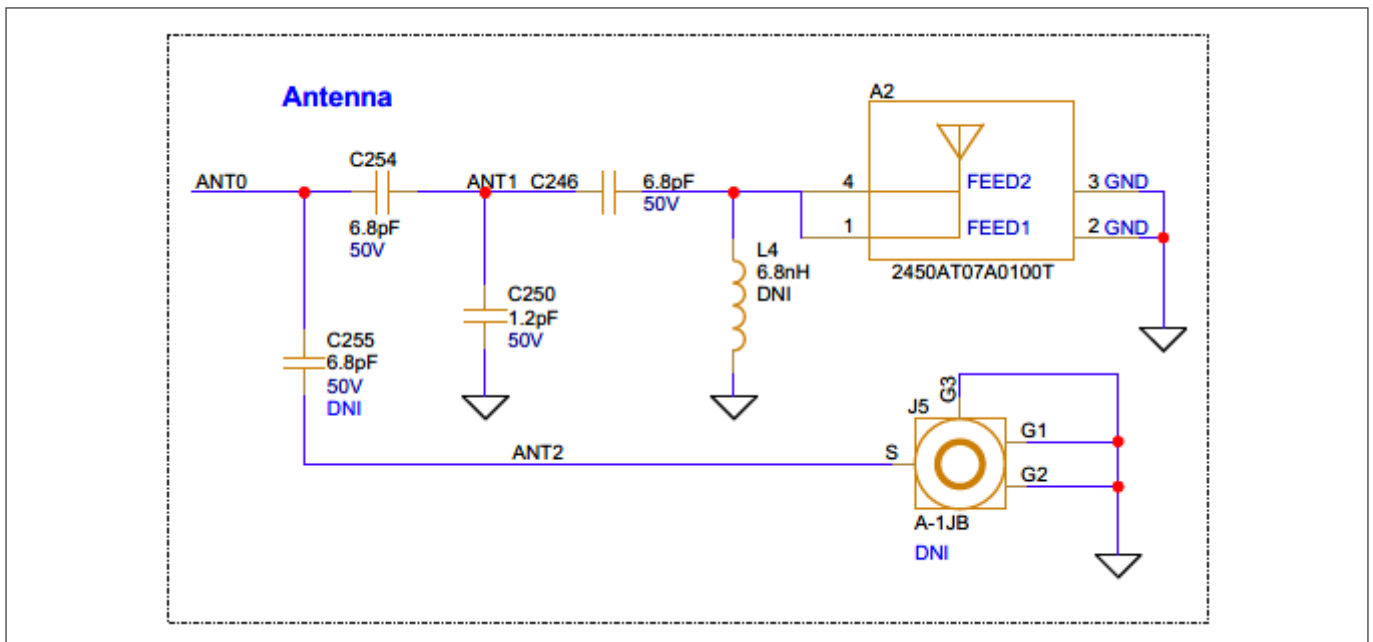

Figure 42 1YN module RF front-end schematic

3.2.13 IO Expansion header

3.2.13.1 Expansion headers

There are two 100 mil pitch expansion headers (**J17** and **J18**) and a low-profile connector (**J15**), which provide connectivity to a few of the PSOC™ 6 MCU GPIOs, whose pin details and IO levels are as follows:

Note: By default, expansion headers **J17** and **J18** are not populated.

3 Hardware

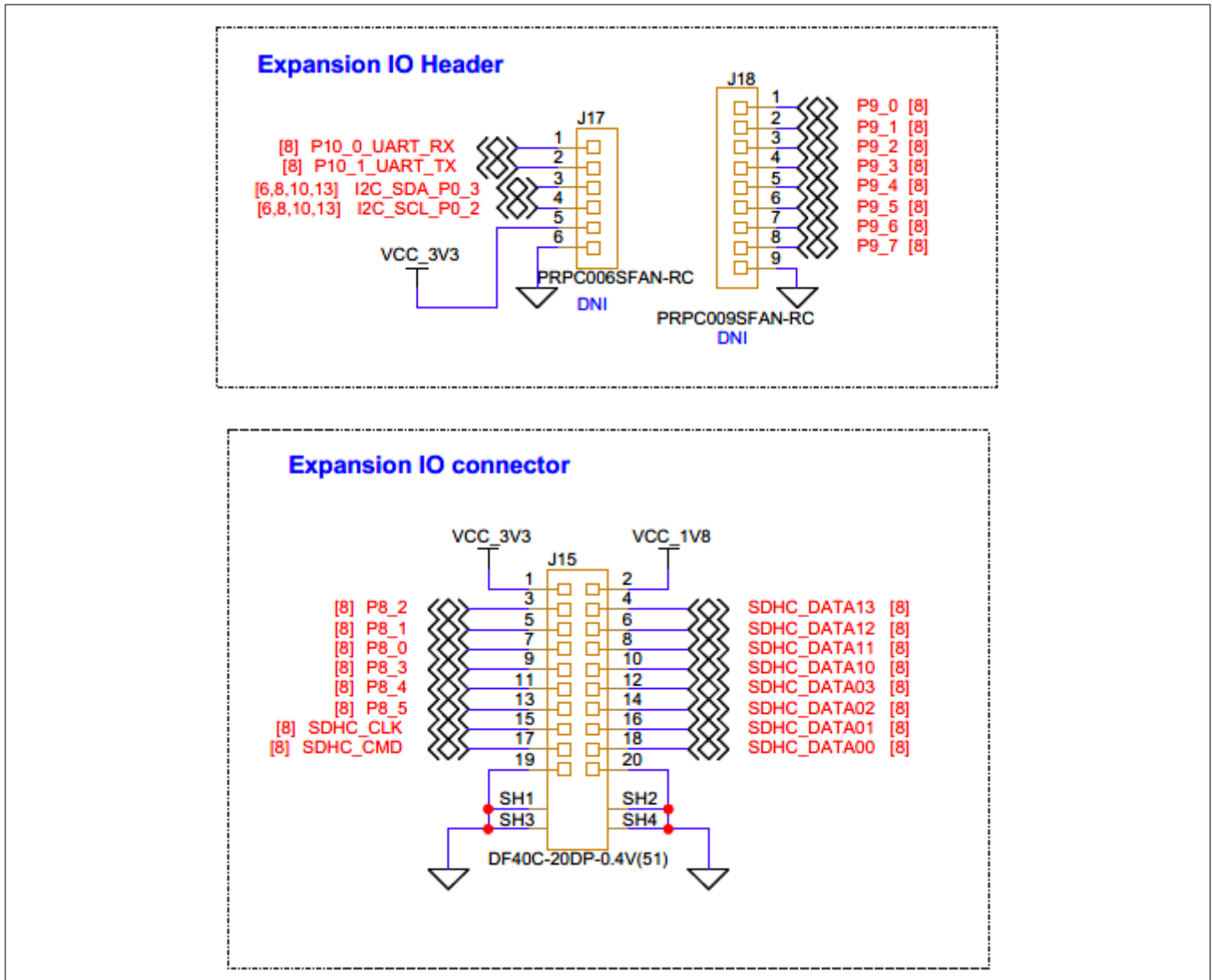

Figure 43 Schematic of the expansion header

Table 16 Pin details of expansion header - J15

Pin details	PSOC™ 6 I/O	Logic level
J15.3	P8[2]	3.3 V
J15.4	P13[7] (SDHC_DATA13)	1.8 V
J15.5	P8[1]	3.3 V
J15.6	P13[6] (SDHC_DATA12)	1.8 V
J15.7	P8[0]	3.3 V
J15.8	P13[5] (SDHC_DATA11)	1.8 V
J15.9	P8[3]	3.3 V
J15.10	P13[4] (SDHC_DATA10)	1.8 V
J15.11	P8[4]	3.3 V
J15.12	P13[3] (SDHC_DATA03)	1.8 V

(table continues...)

3 Hardware

Table 16 (continued) Pin details of expansion header - J15

Pin details	PSOC™ 6 I/O	Logic level
J15.13	P8[5]	3.3 V
J15.14	P13[2] (SDHC_DATA02)	1.8 V
J15.15	P12[5] (SDHC_CLK)	1.8 V
J15.16	P13[1] (SDHC_DATA01)	1.8 V
J15.17	P12[4] (SDHC_CMD)	1.8 V
J15.18	P13[0] (SDHC_DATA00)	1.8 V

Table 17 Pin details of expansion header - J16, J17

Pin details	PSOC™ 6 I/O	Logic level
J17.1	P10[0]	3.3 V
J17.2	P10[1]	3.3 V
J17.3	P0[3]	3.3 V
J17.4	P0[2]	3.3 V
J18.1	P9[0]	3.3 V
J18.2	P9[1]	3.3 V
J18.3	P9[2]	3.3 V
J18.4	P9[3]	3.3 V
J18.5	P9[4]	3.3 V
J18.6	P9[5]	3.3 V
J18.7	P9[6]	3.3 V
J18.8	P9[7]	3.3 V

3.2.13.2 I2C interface connector

The evaluation kit comes with a 4-pin connector designed to extend the I2C interface from the PSOC™ 6 MCU. The extension capability is specifically for adding I2C-based add-on boards.

This interface connector is compatible with QWIIC connection system boards, a product of SparkFun. By using the 4-pin connector, you can attach the QWIIC boards to the PSOC™ 6 MCU. This expands the functionality of the PSOC™ 6 MCU, as it allows it to connect and interact with multiple system boards that support the QWIIC system.

3 Hardware

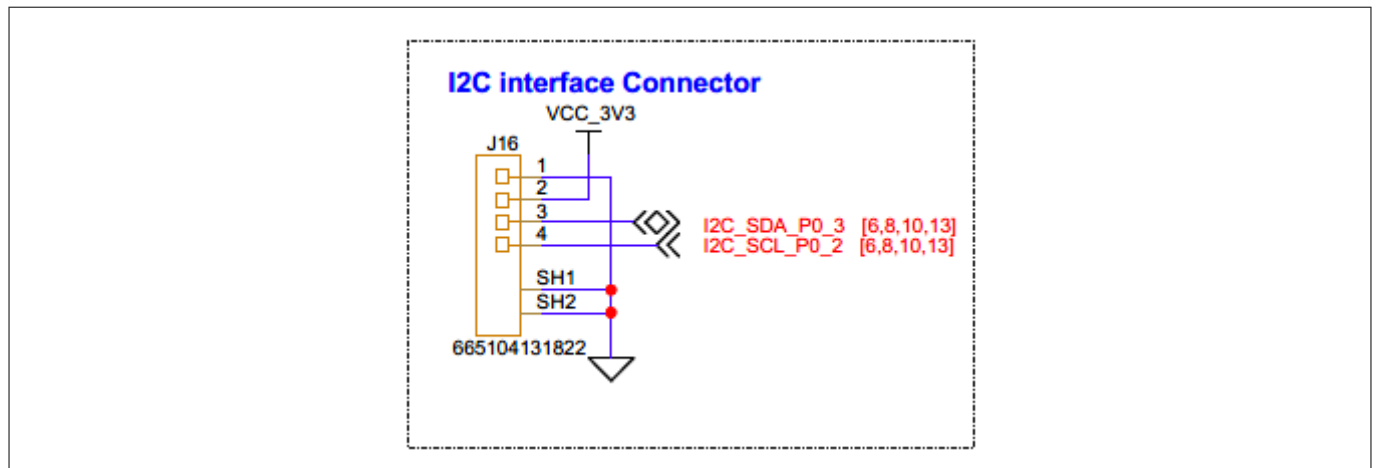

Figure 44 Schematic of I2C interface connector

Table 18 Pin assignment details of I2C interface connector

Pin details	PSOC™ 6 I/O	Logic level
J16.3	P0[3] (I2C_SDA)	3.3 V
J16.4	P0[2] (I2C_SCL)	3.3 V

3.3 Bill of materials

See the bill of materials available on the [kit webpage](#).

Glossary

Glossary

ADC

analog-to-digital converter

BOM

bill of materials

DC

direct current

ECO

external crystal oscillator

ESD

electrostatic discharge

GPIO

general purpose I/O

IC

integrated circuit

IDE

integrated development environment

IoT

internet of things

I2C

inter-integrated circuit

I2S

inter-IC sound

LED

light emitting diode

LPO

low-power oscillator

PC

personal computer

PDL

peripheral driver library

PDM

pulse density modulation

PSOC™

programmable system-on-chip

QSPI

quad serial peripheral interface

SDHC

secure digital host controller

SDIO

secure digital input output

SDK

software development kit

SMIF

serial memory interface

Glossary

SPI

serial peripheral interconnect

SRAM

static random-access memory

SWD

single wire debug

UART

universal asynchronous receiver/transmitter

USB

universal serial bus

WCO

watch crystal oscillator

Revision history**Revision history**

Document revision	Date	Description of changes
**	2024-04-19	Initial release
*A	2025-03-03	Updated Using the OOB example Updated PSoC™ to PSOC™ Changed 'imagimob' to 'DEEPCRAFT™'
*B	2025-12-17	Updated links in the Using the OOB example and Creating a project and program/debug using ModusToolbox™ software sections

Trademarks

Trademarks

The Bluetooth® word mark and logos are registered trademarks owned by Bluetooth SIG, Inc., and any use of such marks by Infineon is under license.

PSOC™, formerly known as PSoC™, is a trademark of Infineon Technologies. Any references to PSoC™ in this document or others shall be deemed to refer to PSOC™.

Trademarks

All referenced product or service names and trademarks are the property of their respective owners.

Edition 2025-12-17

Published by

Infineon Technologies AG

81726 Munich, Germany

© 2025 Infineon Technologies AG

All Rights Reserved.

Do you have a question about any aspect of this document?

Email: erratum@infineon.com

Document reference

IFX-zki1708410577377

For further information on the product, technology, delivery terms and conditions and prices please contact your nearest Infineon Technologies office (www.infineon.com)

Warnings

Due to technical requirements products may contain dangerous substances. For information on the types in question please contact your nearest Infineon Technologies office.

Except as otherwise explicitly approved by Infineon Technologies in a written document signed by authorized representatives of Infineon Technologies, Infineon Technologies' products may not be used in any applications where a failure of the product or any consequences of the use thereof can reasonably be expected to result in personal injury.