

# PRODUCT DATA DRAWING

REVISION HISTORY			
REV	DESCRIPTION	DATE	APPROVED
-	DCN 46856	9/17	FSG

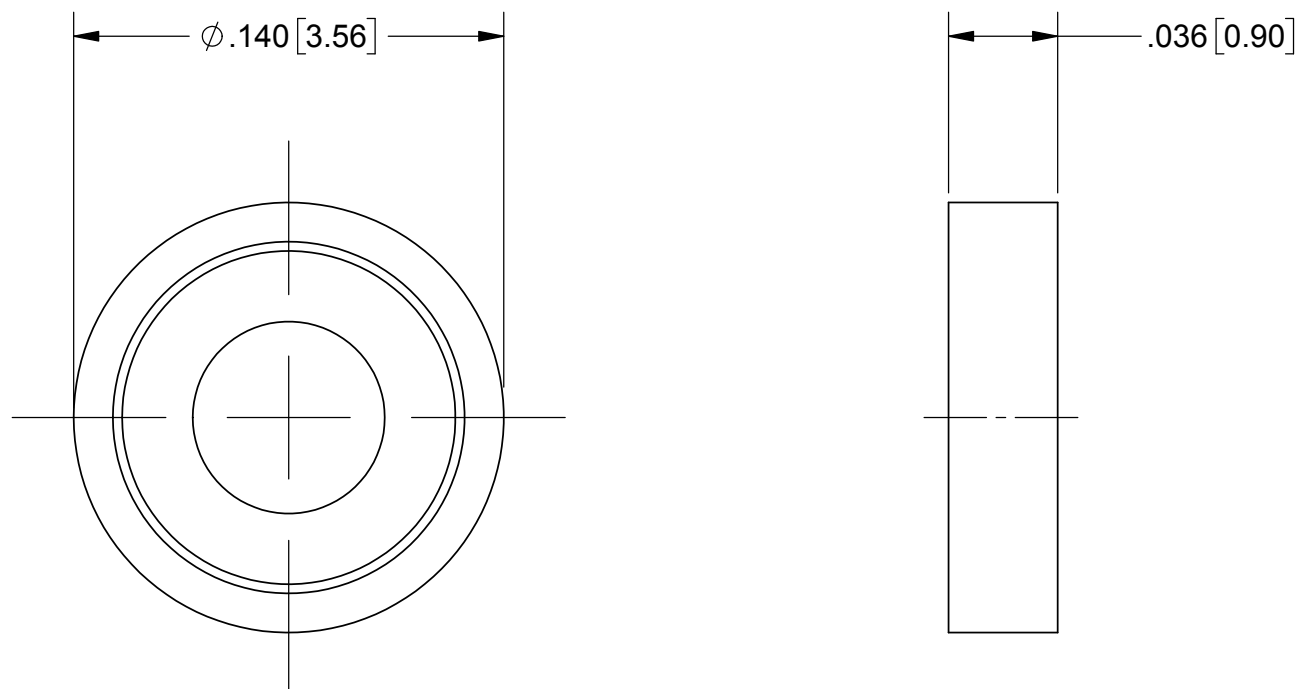
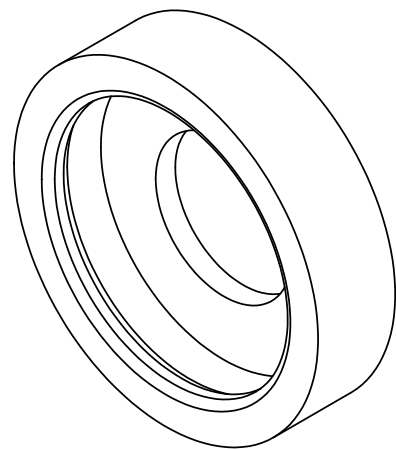

**MATERIAL:**

STAINLESS STEEL PER AMS-5640,  
ALLOY UNS S30300, TYPE 1;  
OR ASTM A582 TYPE 303, COND. A

**FINISH:**

GOLD PER ASTM B488, TYPE II,  
CODE C, CLASS .76, OVER NICKEL  
PER AMS-QQ-N-290, CLASS 1, .00005" MIN.

MATERIAL: SEE NOTES	DIMENSIONS ARE IN INCHES TOLERANCES: FRACTIONAL: ±1/64 ANGULAR: X° ±1'0" X°X' ±15'	UNLESS OTHERWISE SPECIFIED 1) ALL DIMENSIONS ARE IN INCHES (MILLIMETERS) 2) ALL DIMENSIONS ARE AFTER PLATING. 3) BREAK CORNERS & EDGES .005 R. MAX. 4) CHAM. 1ST & LAST THREADS. 5) SURFACE ROUGHNESS 63-MIL-STD-10. 6) DIA.'S ON COMMON CENTERS TO BE CONCENTRIC WITHIN .004 T.I.R. 7) REMOVE ALL BURRS	 Amphenol 2400 Centrepark West Drive, Suite 100 West Palm Beach, FL 33409
FINISH: SEE NOTES	DECIMAL: X ±.030 .XX ±.010 .XXX ±.005		
SURFACE AREA: N/A	INTERPRET DIMENSIONS AND TOLERANCES PER ASME Y14.5M - 1994	DRAWN: GPF 9/26/17 CHECKED: FSG 9/26/17 APPROVED: FSG 9/26/17	TITLE: <b>3mm DETENT SHROUD</b>
PROPRIETARY THE INFORMATION CONTAINED IN THIS DRAWING IS THE SOLE PROPERTY OF SV MICROWAVE, INC. ANY REPRODUCTION IN PART OR AS A WHOLE WITHOUT THE WRITTEN PERMISSION OF SV MICROWAVE, INC IS PROHIBITED.	THIRD ANGLE PROJECTION 		SIZE: <b>B</b> CAGE CODE: <b>95077</b> DWG. NO.: <b>012-80-484/185</b> SCALE: 16:1 SHEET 1 OF 1