

DESCRIPTION

The MP3302 is a step-up converter designed for driving arrays of WLEDs from a single cell Lithium Ion battery. The MP3302 uses current mode, fixed frequency architecture to regulate the LED current, which is measured through an external current sense resistor. Its low 200mV feedback voltage reduces power loss and improves efficiency. The MP3302 is turned off if an over-voltage condition is present due to an open circuit condition.

The MP3302 includes under-voltage lockout, current limiting and thermal overload protection preventing damage in the event of an output overload.

The MP3302 is available in small 5-pin TSOT23 and 8-pin QFN (2mm x 3mm) packages.

FEATURES

- Internal Power MOSFET
- Drives up to 10 Series White LEDs
- Up to 87% Efficiency
- Single Wire Dimming Control
- 1.3MHz Fixed Switching Frequency
- Open Load Shutdown
- Low 200mV Feedback Voltage
- UVLO, Thermal Shutdown
- Internal 1.3A Current Limit
- Available in TSOT23-5 and 2mm x 3mm QFN8 Packages

APPLICATIONS

- 5" ~ 7" LCD Panels
- Handheld Computers and PDAs
- Digital Still Cameras
- Small LCD Displays

"Monolithic Power Systems", "MPS", and "The Future of Analog IC Technology" are Registered Trademarks of Monolithic Power Systems, Inc.

TYPICAL APPLICATION

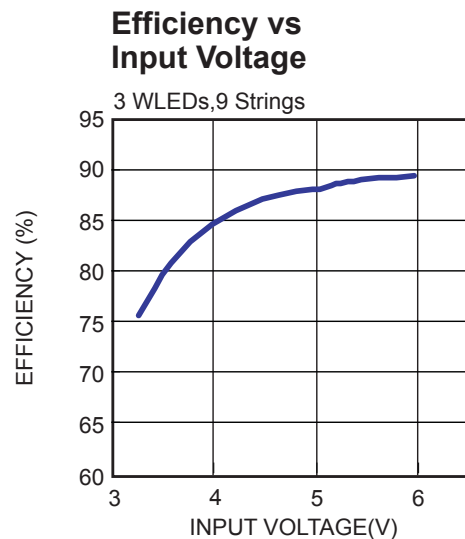
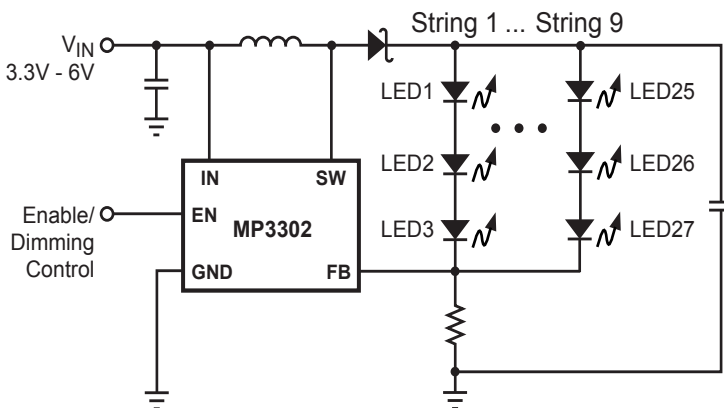

ORDERING INFORMATION

Part Number	Package	Top Marking	Free Air Temperature (T _A)
MP3302DJ*	TSOT23-5	N6	–40°C to +85°C
MP3302DD**	QFN8 (2mm x 3mm)	N7	–40°C to +85°C

* For Tape & Reel, add suffix –Z (e.g. MP3302DJ–Z);
For RoHS Compliant Packaging, add suffix –LF (e.g. MP3302DJ–LF–Z).

** For Tape & Reel, add suffix –Z (e.g. MP3302DD–Z);
For RoHS Compliant Packaging, add suffix –LF (e.g. MP3302DD–LF–Z)

PACKAGE REFERENCE

<p style="text-align: center;">TOP VIEW</p> <p style="text-align: center;">TSOT23-5</p>	<p style="text-align: center;">TOP VIEW</p> <p style="text-align: center;">Exposed Pad Connect to GND</p> <p style="text-align: center;">QFN8 (2mm x 3mm)</p>
---	---

ABSOLUTE MAXIMUM RATINGS ⁽¹⁾

SW Pin	–0.5V to +44V
All Other Pins	–0.3V to +6.5V
Continuous Power Dissipation... (T _A = +25°C) ⁽²⁾	
TSOT23-5	0.57W
QFN8 (2mm x 3mm)	1.56W
Storage Temperature	–55°C to +150°C

Recommended Operating Conditions ⁽³⁾

IN Supply Voltage	2.5V to 6V
SW Pin	V _{IN} to 36V
Operating Junction Temp. (T _J)	–40°C to +125°C

Thermal Resistance ⁽⁴⁾	θ _{JA}	θ _{JC}
TSOT23-5	220	110
QFN8 (2mm x 3mm)	80	16

Notes:

- Exceeding these ratings may damage the device.
- The maximum allowable power dissipation is a function of the maximum junction temperature T_J (MAX), the junction-to-ambient thermal resistance θ_{JA}, and the ambient temperature T_A. The maximum allowable continuous power dissipation at any ambient temperature is calculated by P_D (MAX) = (T_J (MAX)–T_A)/θ_{JA}. Exceeding the maximum allowable power dissipation will cause excessive die temperature, and the regulator will go into thermal shutdown. Internal thermal shutdown circuitry protects the device from permanent damage.
- The device is not guaranteed to function outside of its operating conditions.
- Measured on approximately 1" square of 1 oz copper.

ELECTRICAL CHARACTERISTICS

$V_{IN} = V_{EN} = 5V$, $T_A = +25^{\circ}C$, unless otherwise noted.

Parameters	Symbol	Condition	Min	Typ	Max	Units
Operating Input Voltage	V_{IN}		2.5		6	V
Supply Current (Shutdown)		$V_{EN} = 0V$		4	8	μA
Supply Current (Quiescent)		$V_{FB} = 0.15V$		690	850	μA
Switching Frequency	f_{SW}		1.0	1.3	1.5	MHz
Maximum Duty Cycle		$V_{FB} = 0V$	92			%
Under Voltage Lockout						
IN Under Voltage Lockout	UVLO	V_{IN} Rising		2.25	2.45	V
Under Voltage Lockout Hysteresis				92		mV
Open Lamp Shutdown Threshold	V_{OV}	V_{OV} Rising	40	42	44	V
Enable						
EN OFF Threshold		V_{EN} Falling	0.4			V
EN ON Threshold		V_{EN} Rising			0.6	V
Minimum EN Dimming Threshold		$V_{FB} = 0V$	0.655	0.7	0.845	V
Maximum EN Dimming Threshold		$V_{FB} = 0.2V$	1.275	1.4	1.425	V
Feedback						
FB Voltage		$V_{EN} = 1.5V$	185	200	215	mV
FB Input Bias Current		$V_{FB} = 0.1V$	-600	-300		nA
Output Switch						
SW On-Resistance ⁽⁵⁾	R_{ON}			0.5		Ω
SW Current Limit ⁽⁵⁾		Duty Cycle = 60%		1.33		A
Thermal Shutdown ⁽⁵⁾				150		$^{\circ}C$

Notes:

5) Guaranteed by design.

PIN FUNCTIONS

TSOT23-5 Pin #	QFN8 Pin #	Name	Pin Function
1	8	SW	Power Switch Output. SW is the drain of the internal MOSFET switch. Connect the power inductor and output rectifier to SW. SW can swing between GND and 36V.
2	1, 5	GND, Exposed Pad	Ground. Connect exposed pad to GND plane for proper thermal performance.
3	6	FB	Feedback Input. The MP3302 regulates the voltage across the current sense resistor between FB and GND. Connect a current sense resistor from the bottom of the LED string to GND. Connect the bottom of the LED string to FB. The regulation voltage is 200mV.
4	4	EN	ON/OFF Control and Dimming Command Input. A voltage greater than 0.6V will turn the part on and less than 0.4V will turn the part off. If the EN pin voltage is between 0.7V and 1.4V, V_{FB} is regulated between 0V and 200mV. To use PWM dimming, apply a 200Hz to 1KHz square wave signal with amplitude greater than 1.5V to this pin.
5	2	IN	Input Supply Pin. Must be locally bypassed.
	3	NC	No Connect.

TYPICAL PERFORMANCE CHARACTERISTICS

$V_{IN} = 5V$, 3WLEDs 9Strings, unless otherwise noted.

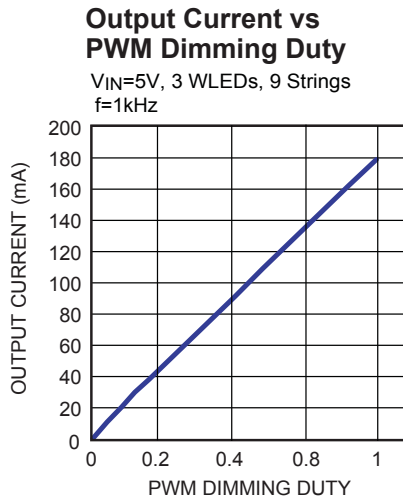
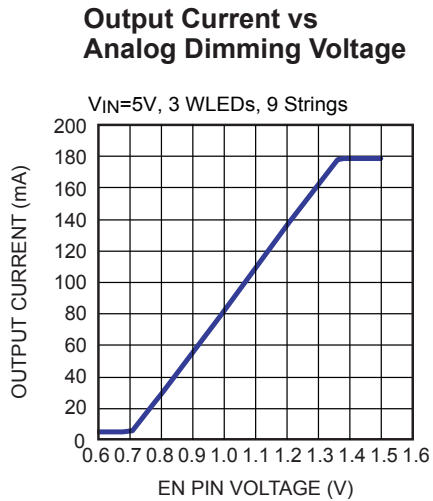
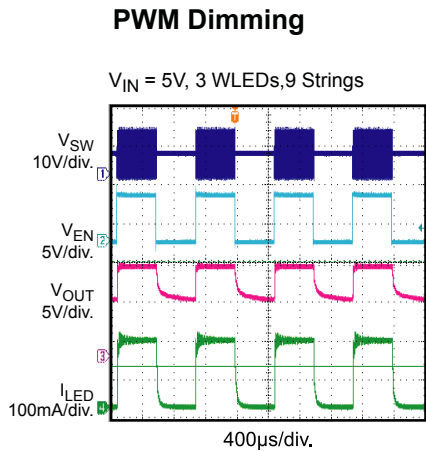
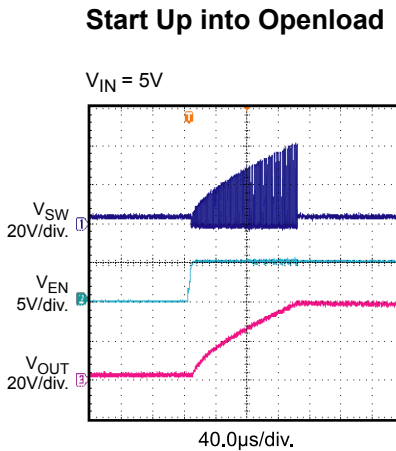
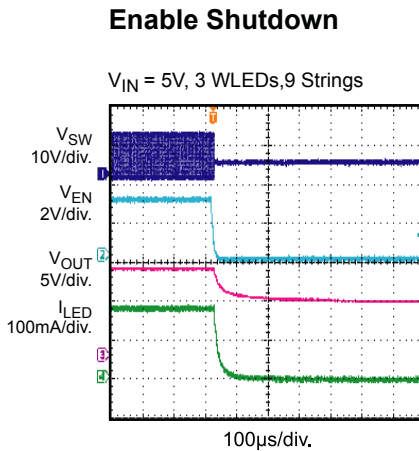
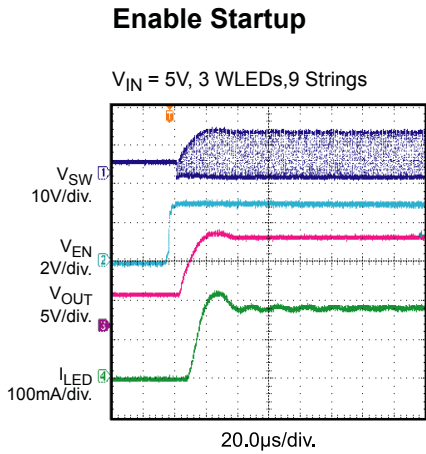
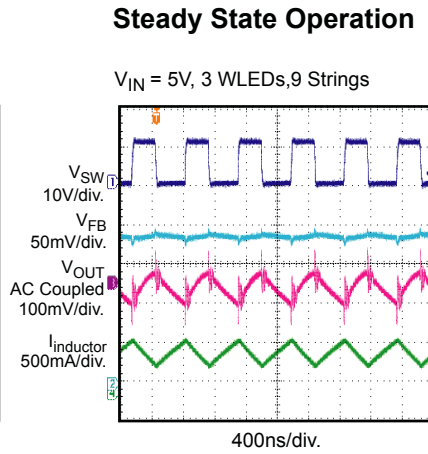
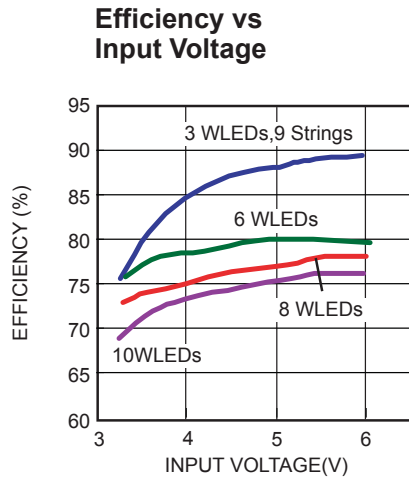

OPERATION

The MP3302 uses a constant frequency, peak current mode boost regulator architecture to regulate the series string of white LEDs. The operation of the MP3302 can be understood by referring to the block diagram of Figure 1.

At the start of each oscillator cycle the FET is turned on through the control circuitry. To prevent sub-harmonic oscillations at duty cycles greater than 50 percent, a stabilizing ramp is added to the output of the current sense amplifier and the result is fed into the positive input of the PWM comparator. When this voltage equals the output voltage of the error amplifier the power FET is turned off.

The voltage at the output of the error amplifier is an amplified version of the difference between the 200mV reference voltage and the feedback voltage. In this way the peak current level keeps the output in regulation.

If the feedback voltage starts to drop, the output of the error amplifier increases. This results in more current flowing through the power FET, thus increasing the power delivered to the output.

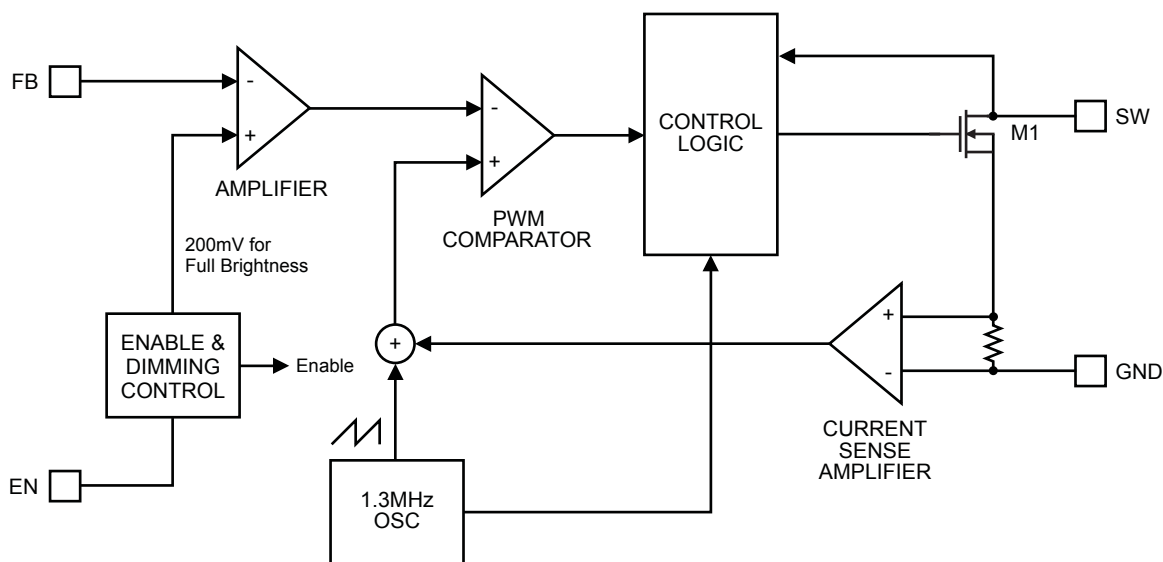

Figure 1—Functional Block Diagram

APPLICATION INFORMATION

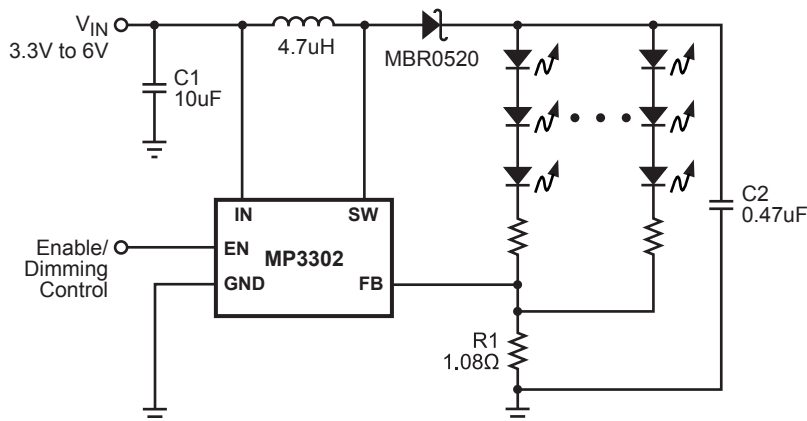

Figure 2—Circuit for Driving 9 Strings of 3 WLEDs

A typical application circuit can be seen in Figure 2. The 9 strings of 3 white LEDs can be driven from a voltage supply range of 3.3V to 6V at an output current of 180mA. A 0.47µF output capacitor is sufficient for most applications. A 4.7µH inductor with low DCR (Inductor DC resistance) is recommended to improve efficiency. A 10µF ceramic capacitor is recommended for the input capacitance in the real system. Schottky diodes have fast recovery and a low forward voltage and are recommended. Schottky diodes rated with 500mA are sufficient for the MP3302. The MP3302 has internal soft-start to limit the amount of current through VIN at startup and to also limit the amount of overshoot on the output.

The ramped voltage that is added to the current sense amplifier reduces the current output as the duty cycle increases. As more LEDs are added, the output voltage rises but the current that can be delivered to the load is reduced as well.

Setting the LED Current

The LED current is controlled by the feedback resistor, R1. The current through the LEDs is given by the equation $200\text{mV}/R1$. Table 1 shows the selection of resistors for a given LED current.

Table 1— I_{LED} vs. R1

I_{LED} (mA)	R1 (Ω)
1	200
5	40
10	20
20	10
60	3.33
180	1.11

LED Current Programming

Applying a DC voltage between 0.7V and 1.4V to EN pin programs a feedback voltage between 0V and 200mV. Thus the analog dimming of LED current can be achieved. The DC dimming voltage must be locally bypassed to prevent noise interfering with the feedback reference level.

PWM Dimming

Apply a 200Hz to 1kHz square waveform to the EN pin to implement PWM dimming of the LEDs. The minimum recommended amplitude of the PWM signal is 1.5V.

For high frequency PWM dimming (>1kHz), it is also recommended that the dimming control be implemented as shown in Figure 3. The cut off frequency of the RC filter should be 10 times lower than that of the input PWM signal. For example, when the PWM frequency is 20kHz, a 20kΩ resistor and 100nF capacitor can be used. The DC voltage on EN pin is then equal to the PWM high level voltage multiplies the PWM duty. The DC voltage from 0.7V to 1.4V programs the output current from 0~100%.

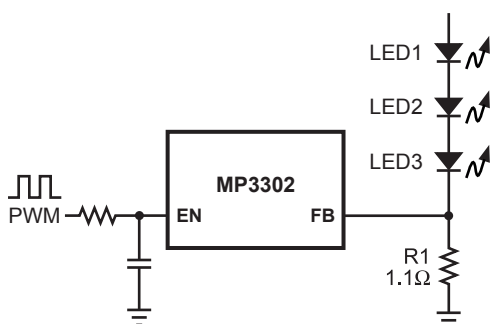

Figure 3—High Frequency PWM Dimming Control

Open Load Protection

Open Load protection will shut off the MP3302 if the output voltage goes too high. In some cases an LED may fail, this will result in the feedback voltage always being zero. The part will run at maximum duty cycle boosting the output voltage higher and higher. If the output ever exceeds 42V, the MP3302 will shut down. The part will not switch again until the power is recycled.

Layout Considerations

Careful attention must be paid to the PCB board layout and components placement. Proper layout of the high frequency switching path is critical to prevent noise and electromagnetic interference problems. The current loop of IC, output diode, and output capacitor should be as short as possible.

The IN pin of the IC must be locally bypassed. A RC filter is highly recommended for eliminating the noise on IN pin. It could be implemented as shown in Figure 4.

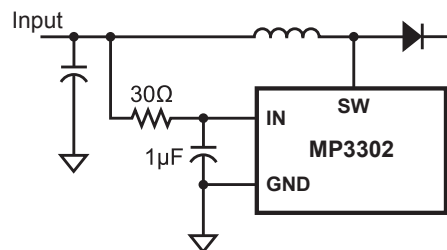

Figure 4—Input Bias Filtering

TYPICAL APPLICATION CIRCUITS

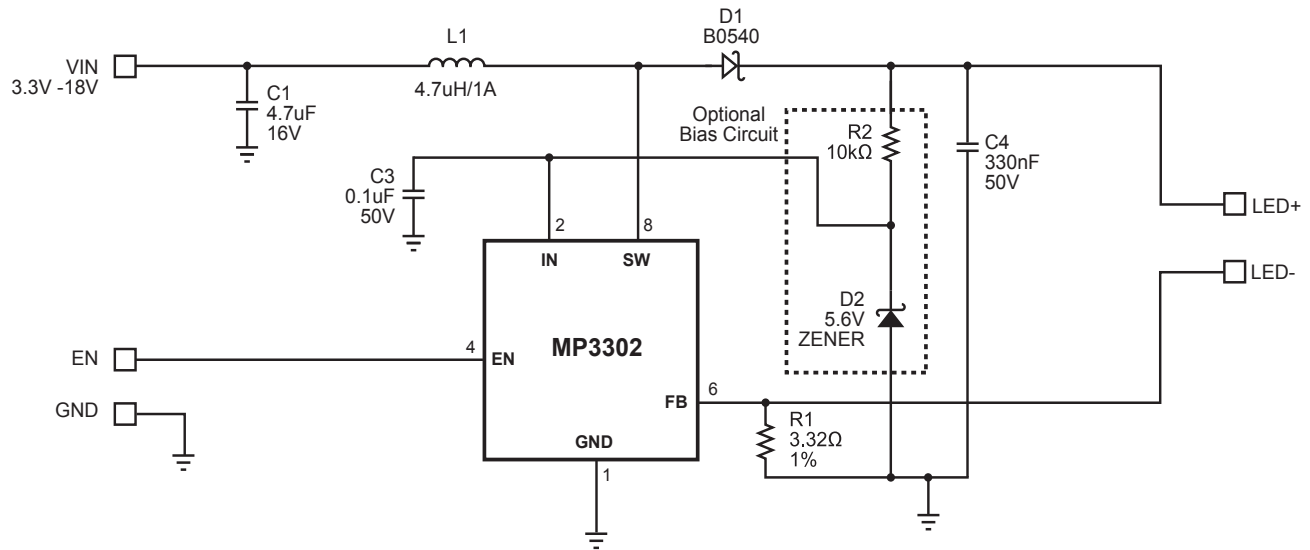

Figure 5 — Driving 27 WLEDs (9 WLEDs in Series and 3 Strings Paralleled) with 3.3V–18V Input Voltage

In order to improve the MOSFET on-resistance at low input voltage and make the chip compatible for high input voltage, the additional bias circuit should be used.

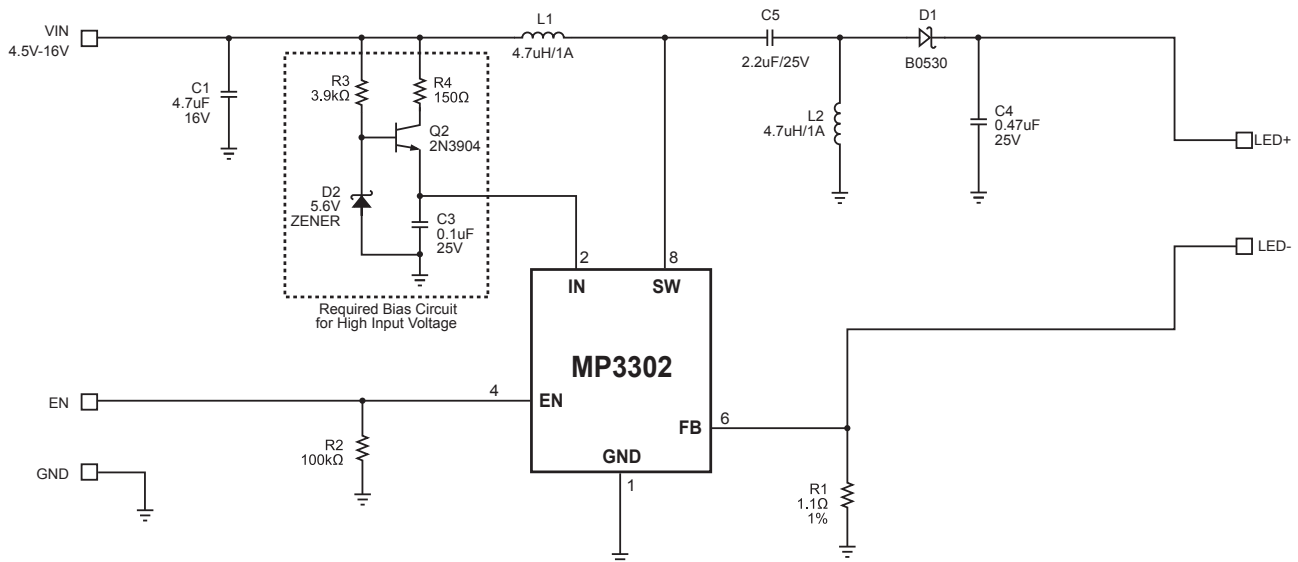

Figure 6 — Wide Input Voltage Sepic Converter for 27 WLEDs (3 WLEDs in Series and 9 Strings Paralleled)

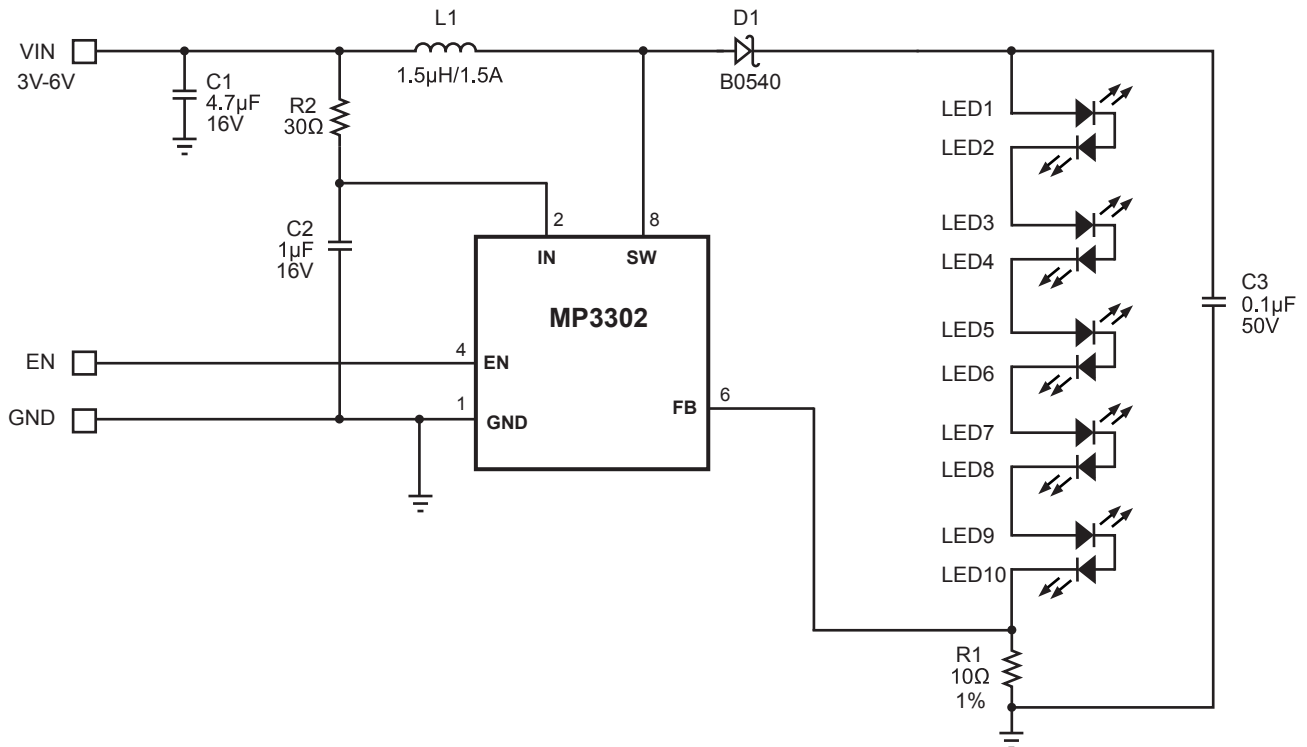

Figure 7 — Driving 10 WLEDs in Series with 3V—6V Input Voltage

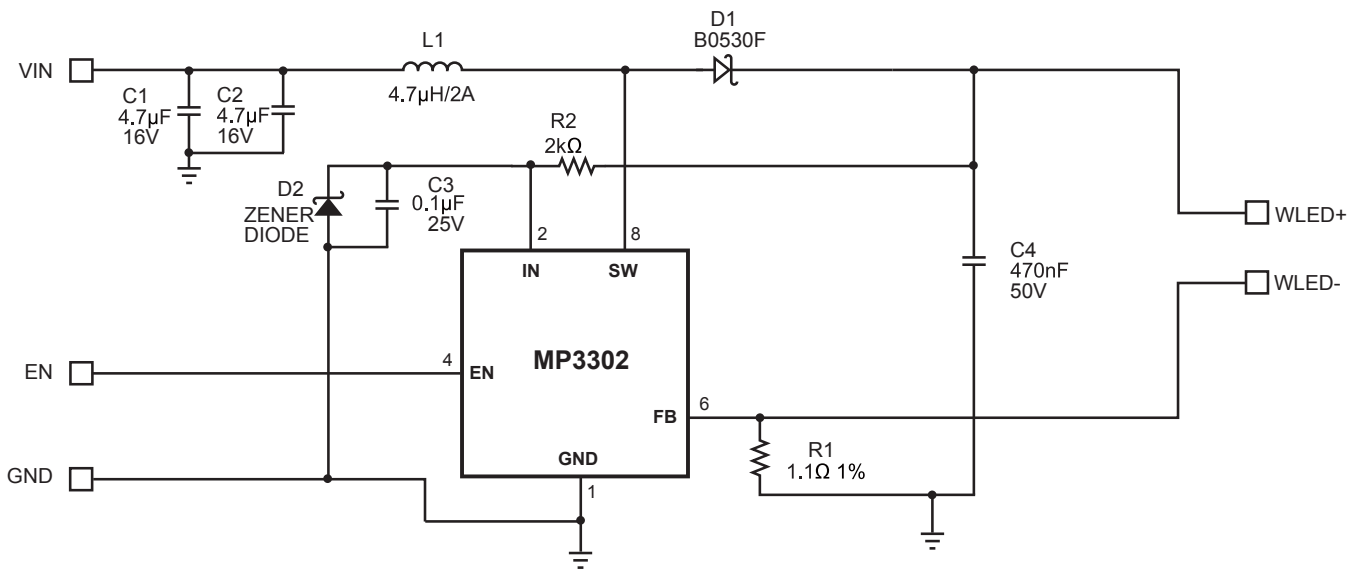
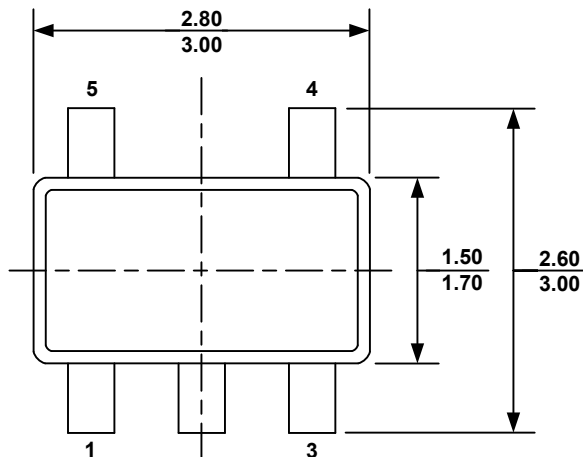

Figure 8 — Driving 27 WLEDs (3 WLEDs in Series and 9 Strings) with 3 V Input Voltage

PACKAGE INFORMATION

TSOT23-5



TOP VIEW

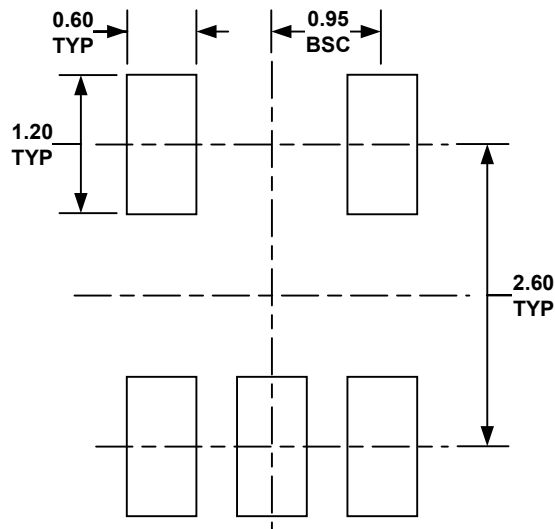

RECOMMENDED LAND PATTERN

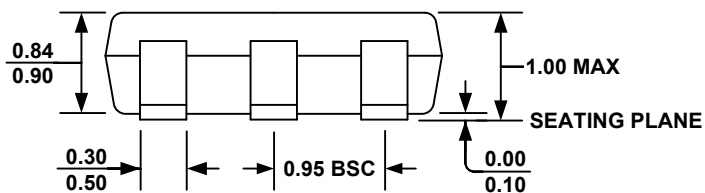

FRONT VIEW

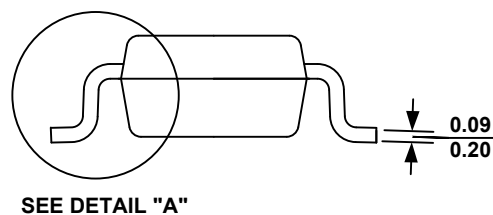

SEE DETAIL "A"

SIDE VIEW

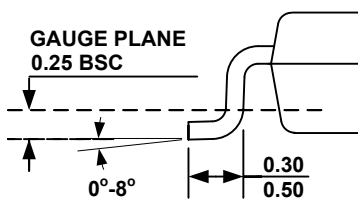

DETAIL "A"

NOTE:

- 1) ALL DIMENSIONS ARE IN MILLIMETERS.
- 2) PACKAGE LENGTH DOES NOT INCLUDE MOLD FLASH, PROTRUSION OR GATE BURR.
- 3) PACKAGE WIDTH DOES NOT INCLUDE INTERLEAD FLASH OR PROTRUSION.
- 4) LEAD COPLANARITY (BOTTOM OF LEADS AFTER FORMING) SHALL BE 0.10 MILLIMETERS MAX.
- 5) DRAWING CONFORMS TO JEDEC MO-193, VARIATION AA.
- 6) DRAWING IS NOT TO SCALE.

