



TAOGLAS®



Datasheet

Part No:
PCS.25.A

Description

Wi-Fi® / Bluetooth® 2.4GHz FR4 SMD Antenna

Features:

2.4GHz FR4 SMD Antenna
Dimensions: 15x3x3mm
FR4 material SMD Antenna
RoHS & Reach Compliant

1.	Introduction	2
2.	Specifications	3
3.	Mechanical Drawing (in mm)	4
4.	Antenna Integration Guide	5
5.	Application Note	12
6.	Packaging	16
7.	Antenna Characteristics	17
8.	Radiation Patterns	19
<hr/>		
	Changelog	22

Taoglas makes no warranties based on the accuracy or completeness of the contents of this document and reserves the right to make changes to specifications and product descriptions at any time without notice. Taoglas reserves all rights to this document and the information contained herein. Reproduction, use or disclosure to third parties without express permission is strictly prohibited.

Ireland & USA
ISO 9001:2015
Certified



Taiwan
ISO 9001:2015
Certified



1. Introduction



The Taoglas PCS.25.A is an expertly designed 2.4GHz antenna for various Bluetooth® and Wi-Fi® applications. The PCS.25 is an FR4 antenna designed to be mounted via SMD on a PCB, engineered to operate both with, and without copper clearance on all PCB layers, meaning it can be used on boards where space is at a premium. The PCS.25.A has a compact form factor of just 15x3x3mm, allowing it to be used in areas where other antennas that require large keep out areas, several matching components and vast ground planes to operate are currently used.



Top View of PCB with Copper Clearance

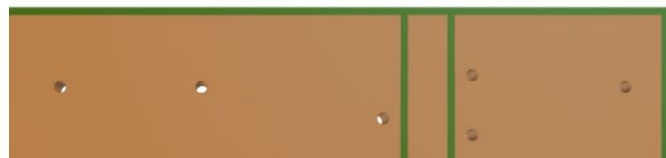

Top View of PCB without Copper Clearance

Typical applications that the PCS.25.A is suitable for include wearables, handheld Wi-Fi® devices, keyless entry systems and Smart Telemedicine and healthcare.

Taoglas FR4 antennas can be specifically tuned to customer-specific device environments, subject to NRE and MOQ. Contact your regional Taoglas customer support team to request these services or additional support to integrate and test this antenna's performance in your device.

2. Specifications

Wi-Fi Electrical									
Band	Frequency (MHz)		Efficiency (%)	Average Gain (dB)	Peak Gain (dBi)	Impedance	Polarization	Radiation Pattern	Max. input power
Wi-Fi - 2GHz	2400-2500	With Clearance	52	-2.9	2	50 Ω	Linear	Omni	10W
		Without Clearance	31	-5.1	0.1				
*Tested on 50x50mm ground plane									

Mechanical	
Dimensions	15 x 3 x 3mm
Weight	2g
Material	FR4

Environmental	
Temperature Range	-40°C to 85°C
Humidity	Non-condensing 65°C 95% RH
Moisture Sensitivity Level (MSL)	3

3. Mechanical Drawing (in mm)

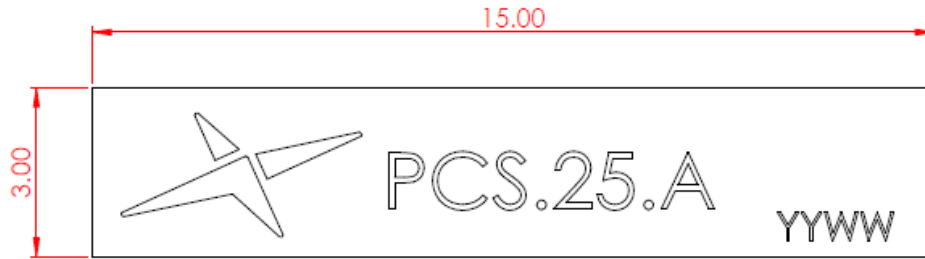

TOP VIEW



FRONT VIEW

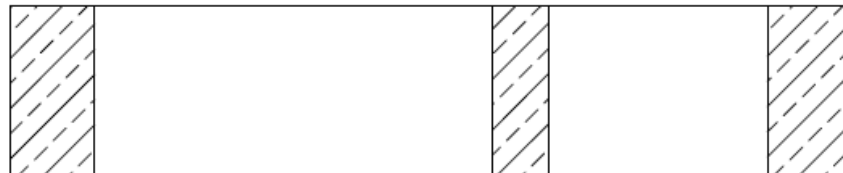

BOTTOM VIEW

4. Antenna Integration Guide

Following this recommendation on how to optimally integrate the PCS.25.A into you design. This antenna has 3 pads, where one is used for the RF Feed. Taoglas recommends using a minimum of 50x50mm ground plane (PCB) to ensure optimal performance. The antenna should be placed on the corner of the PCB to take advantage of the smaller ground plane.



Top view of Reference Design PCB.

Please find the Integration files in Altium, 2D formats and the 3D model for the PCS.25.A here:
<https://www.taoglas.com/product/wi-fi-bluetooth-2-4ghz-fr4-chip-antenna/>

4.1 Schematic Symbol and Pad Definitions

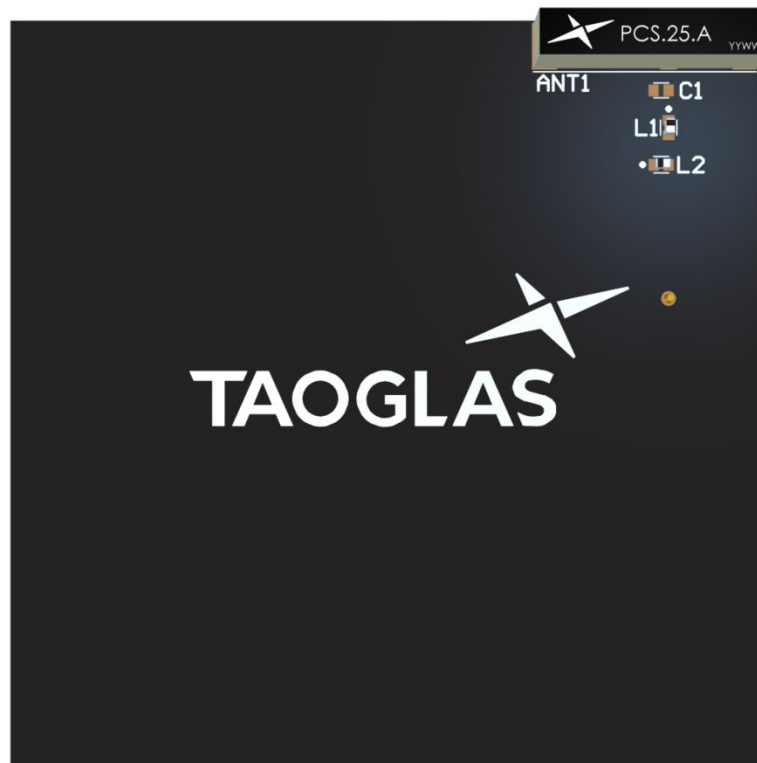

Above is a 3D model of the PCS.25.A on a Reference Design PCB.

The circuit symbol for the PCS.25.A is shown below. The antenna has 3 Pads as indicated below.

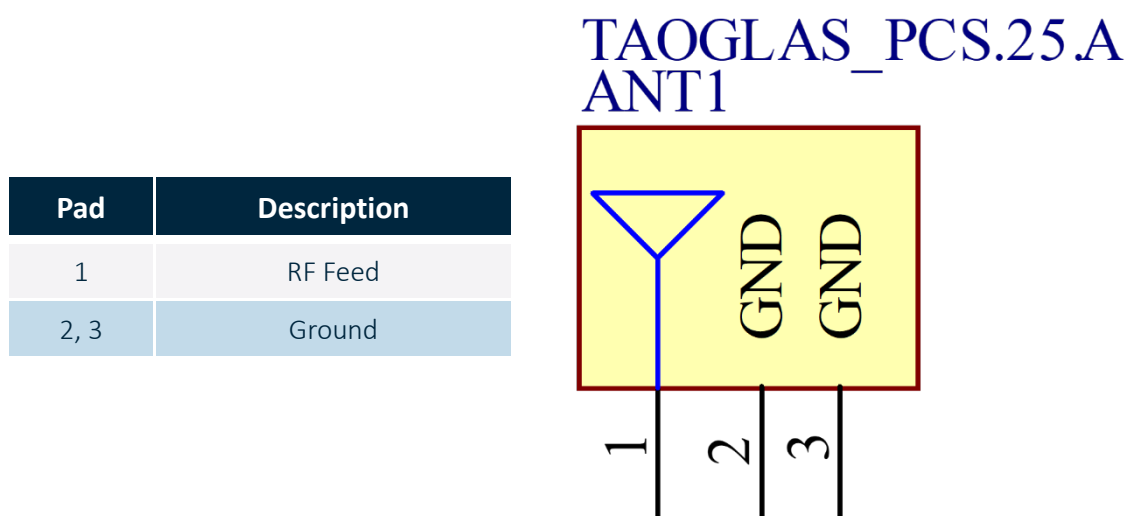

4.2 Antenna Copper Footprint

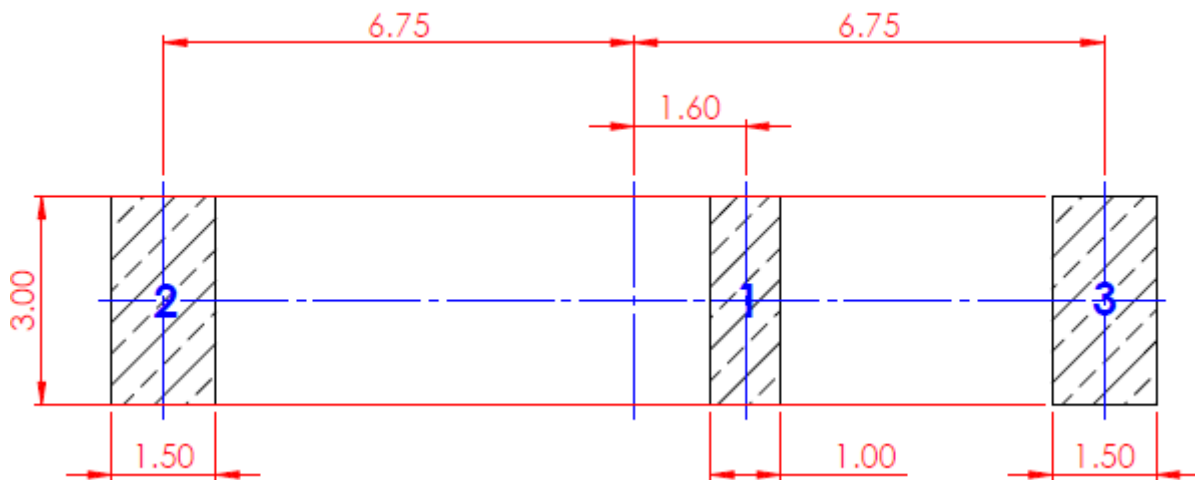

4.3 Top Solder Paste

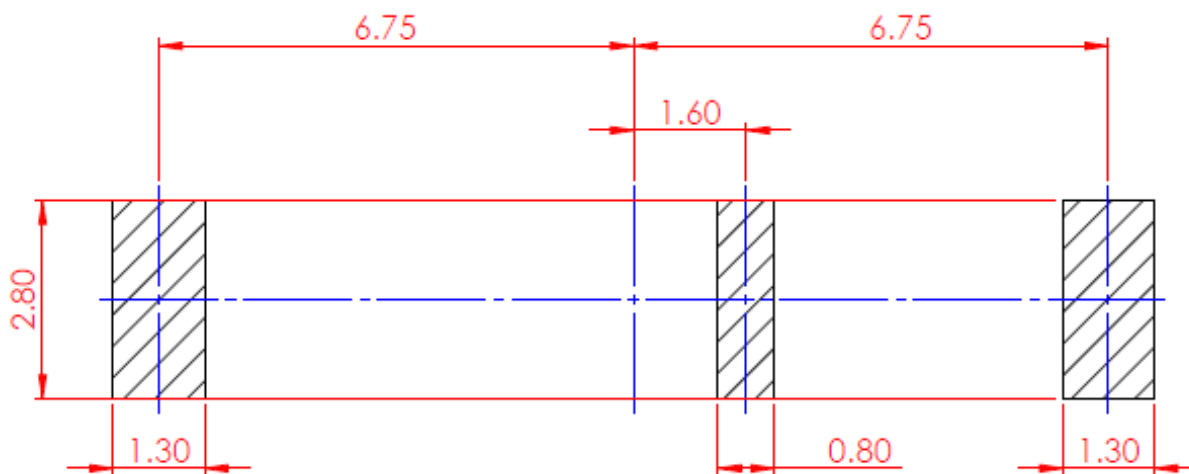

4.4 Copper Keep-out

The footprint and clearance on the PCB must comply with the antenna's specification. The PCB layout shown in the diagrams below demonstrates the PCS.25.A clearance area. The copper keep out area applies to all layers on the PCB. The copper clearance area extends to 3mm in length and 15mm in width around the antenna. The board edge clearance should be a minimum of 0.1mm, example shown below is 0.2mm.

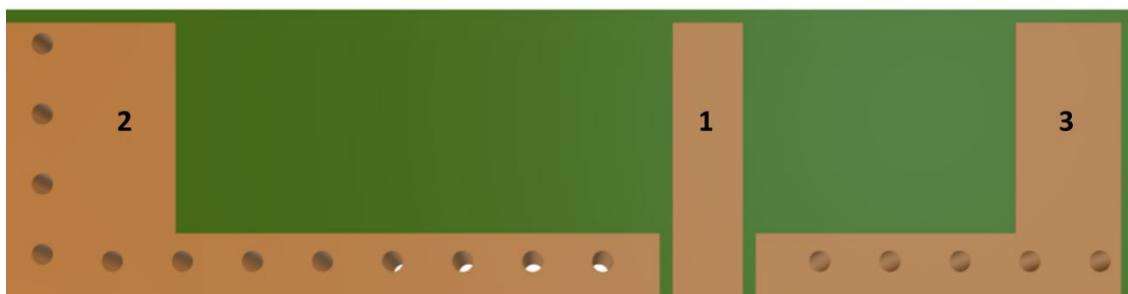
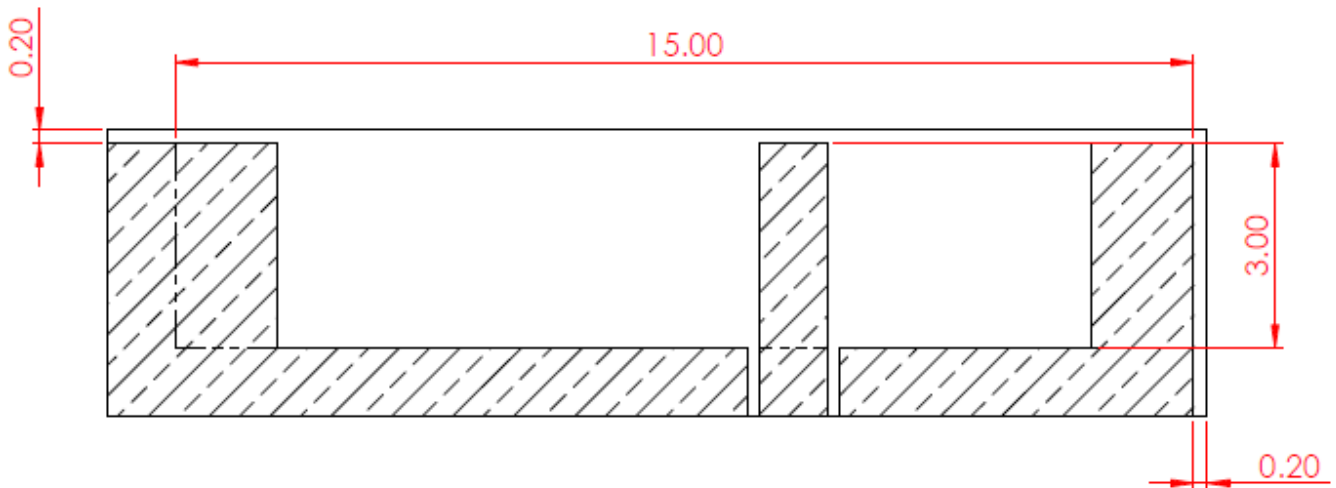

4.5 Evaluation Board

Matching components with the PCS.25.A are required for the antenna to have optimal performance in the spaces specified in the schematic below. Additional matching components may be necessary for your device, Taoglas recommends incorporating extra component footprints, forming a “pi” network, for the PCS.25.A.

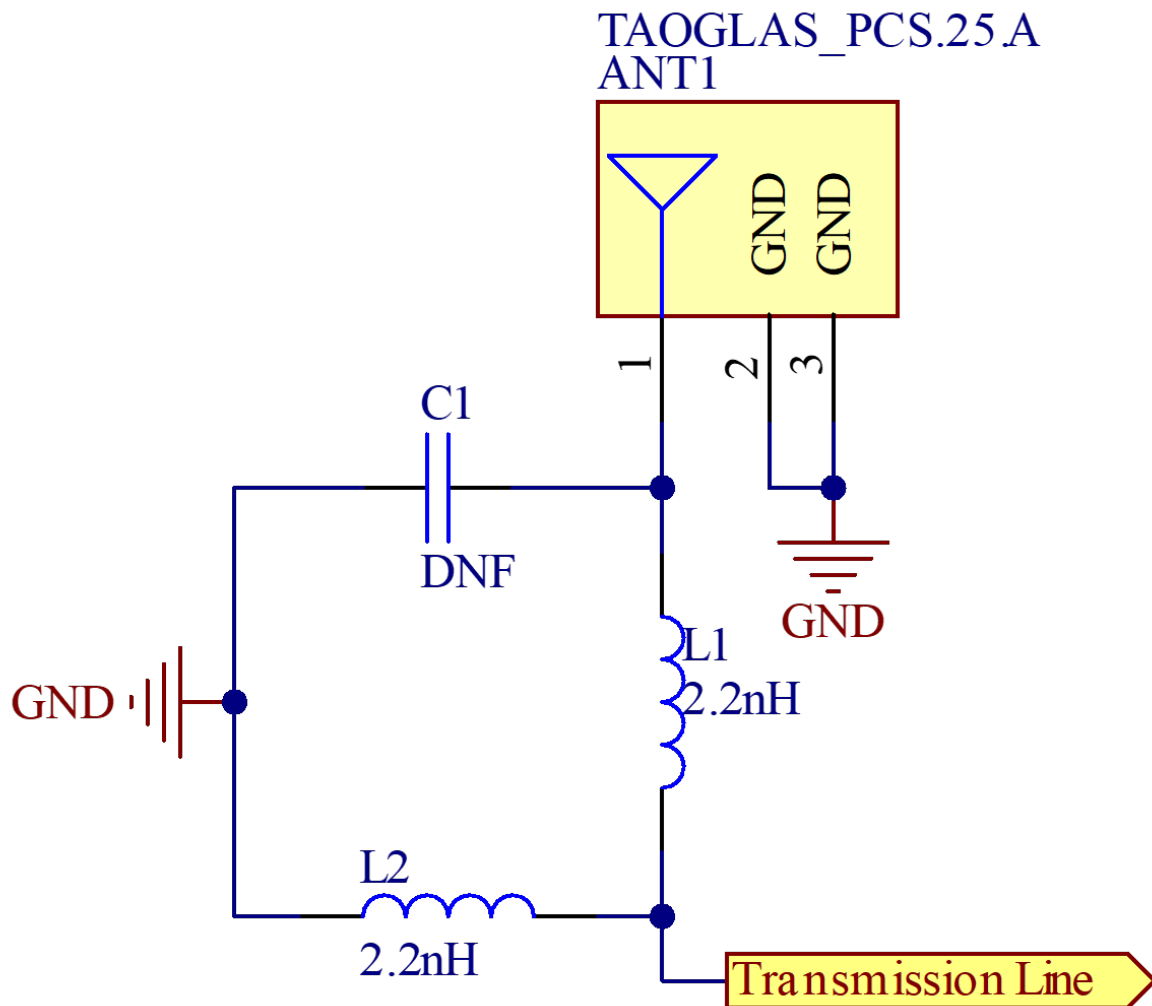

Designator	Type	Value	Manufacturer	Manufacturer Part Number
C1	Capacitor	Not Fitted	-	-
L1, L2	Inductor	2.2nH	TDK	MHQ1005P2N2CT000

4.6 Antenna Integration

The PCS.25.A should be placed in the corner of the PCB to take advantage of the ground plane. The RF trace must maintain a 50 Ohm transmission line. A “Pi” Matching Network is recommended for the RF transmission line, the values and components for the matching circuit will depend on the tuning needed. Ground vias should be placed around the transmission line and the copper clearance area.

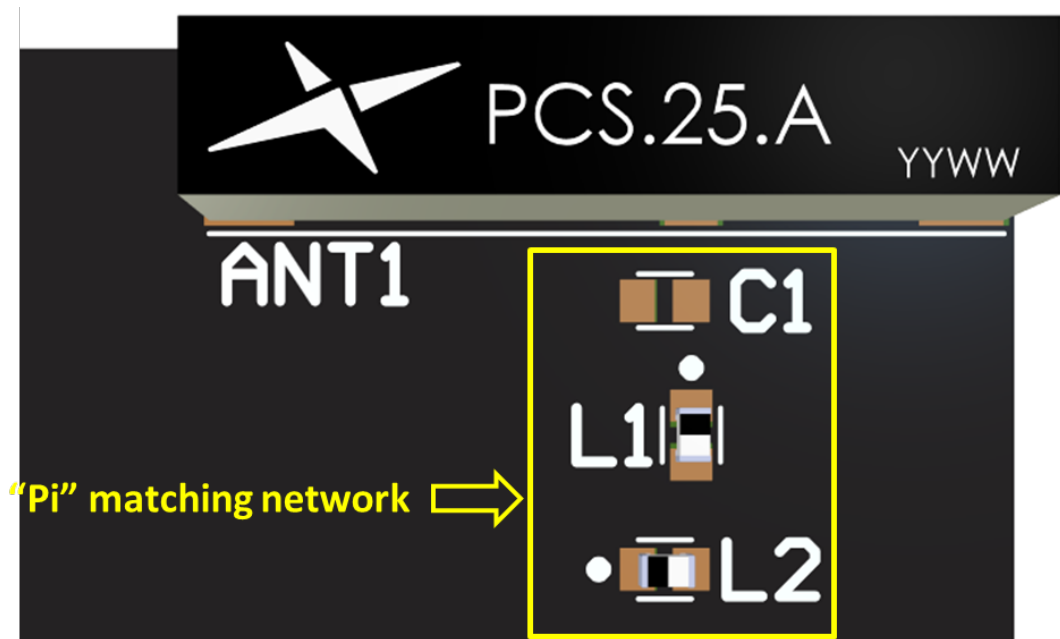

PCS.25.A antenna mounted on a Reference Design PCB, showing “Pi” matching network.

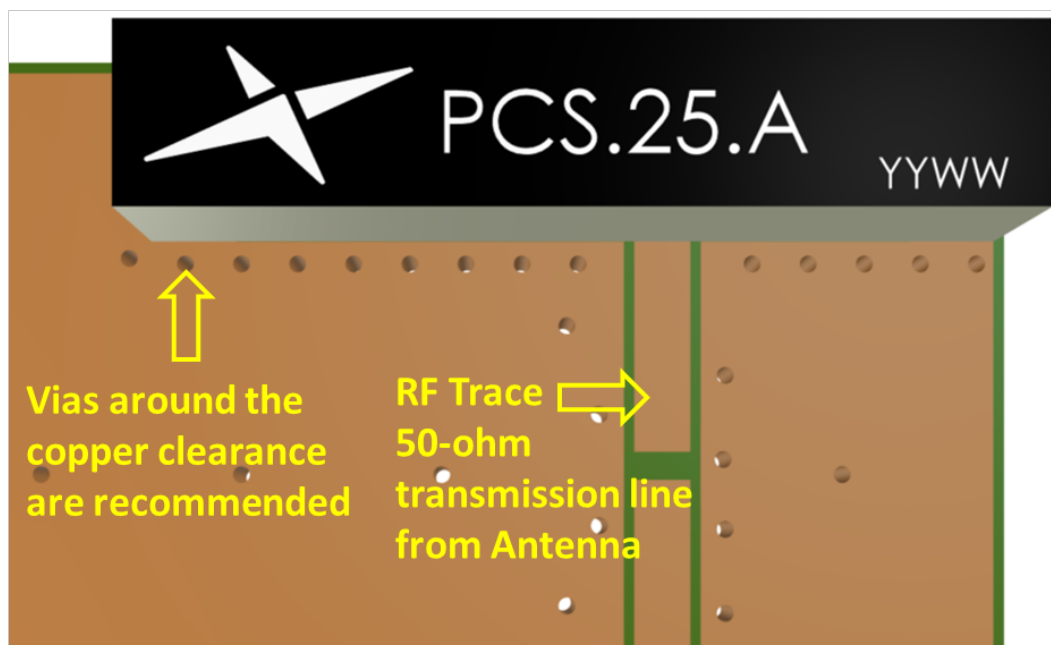

PCS.25.A antenna mounted on a Reference Design PCB, showing transmission line and integration notes.

4.7 Final Integration

The top side image shown below highlights the antenna transmission line. Taoglas recommends using a minimum of 50x50mm ground plane (PCB) to ensure optimal performance.



Top Side (PCS.25.A placement on 50x50mm Reference Design PCB)

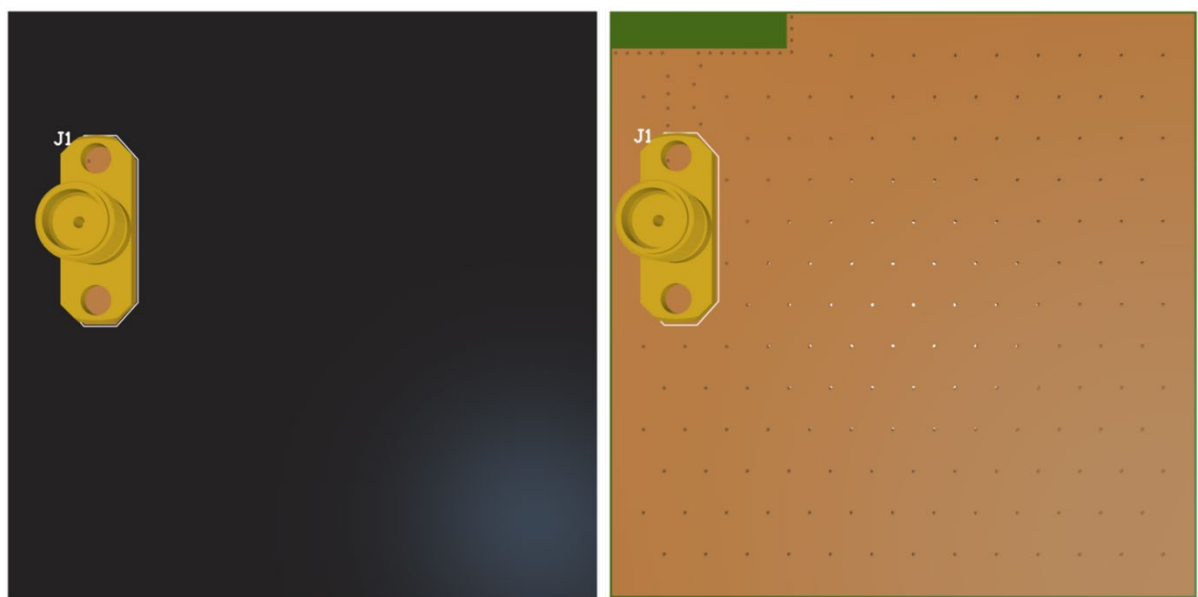

Bottom Side

5. Application Note

The following application note shows how to integrate the PCS.25.A into a design without the copper clearance area. This antenna has 3 Pads, where one Pad is used for the RF Feed. Taoglas recommends using a minimum of 50x50mm ground plane (PCB) to ensure optimal performance. The antenna should be placed on the corner of the PCB to take advantage of the ground plane.



Top view of Reference Design PCB.

5.1 Copper Area

The footprint on the PCB must comply with the antenna's specification. The PCB layout shown in the diagrams below demonstrates the PCS.25.A copper area. The board edge clearance should be a minimum of 0.1mm, example shown below is 0.2mm.

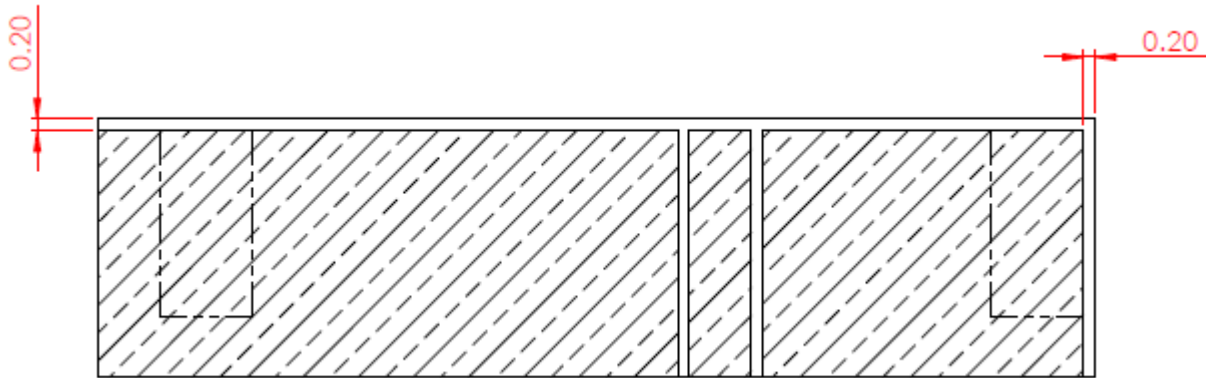

5.2 Evaluation Board

Matching components with the PCS.25.A are required for the antenna to have optimal performance in the spaces specified in the schematic below. Additional matching components may be necessary for your device, Taoglas recommends incorporating extra component footprints, forming a “pi” network, for the PCS.25.A.

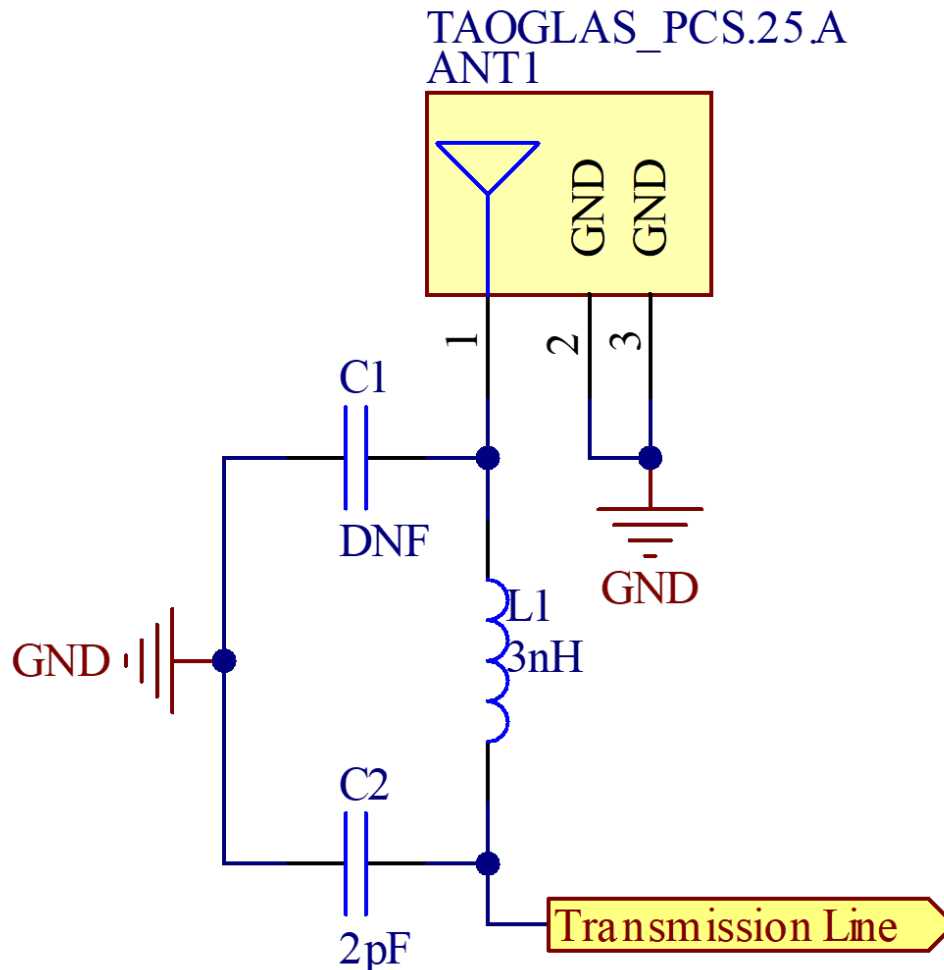

Designator	Type	Value	Manufacturer	Manufacturer Part Number
C1	Capacitor	Not Fitted	-	-
C2	Capacitor	2pF	TDK	GRM1555C1H2R0CA01D
L1	Inductor	3nH	TDK	MHQ1005P3N0BT000

5.3 Final Integration

The top side image shown below highlights the antenna transmission line. Taoglas recommends using a minimum of 50x50mm ground plane (PCB) to ensure optimal performance.



Top Side (PCS.25.A placement on 50x50mm Reference Design PCB)

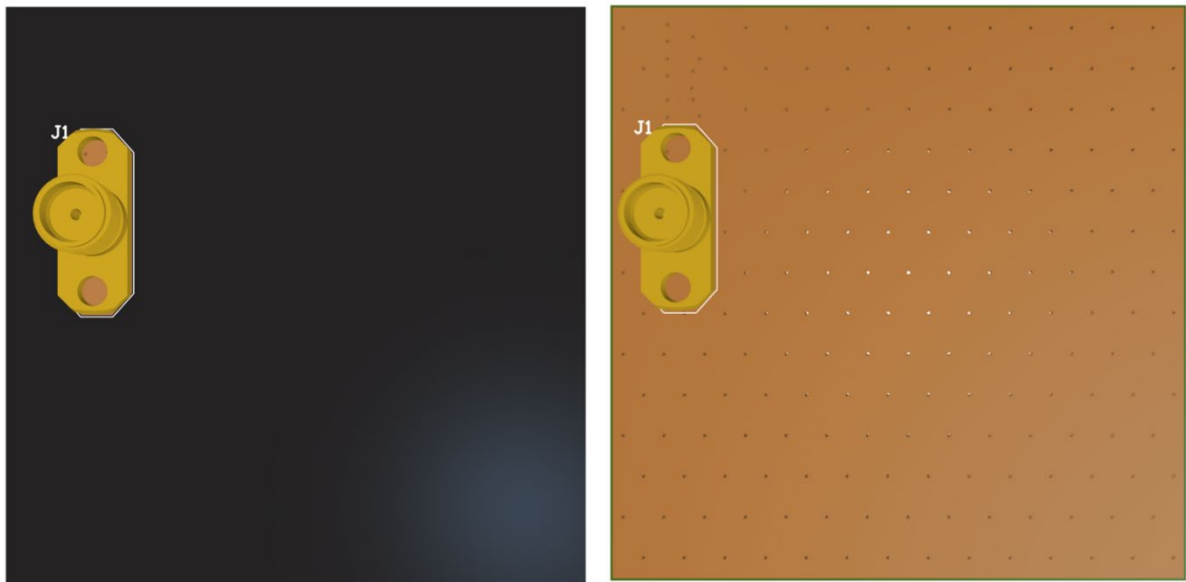

Bottom Side

6. Packaging

2000pcs PCS.25.A per Reel

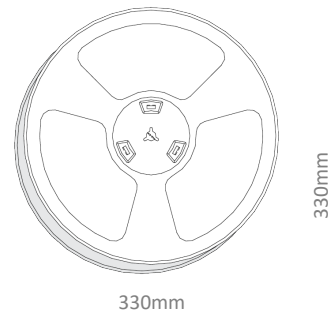

2000pcs PCS.25.A per Inner Carton
Dimensions: 350*350*70 mm

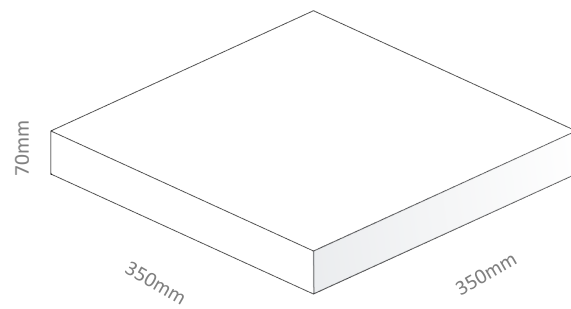

6000pcs PCS.25.A per Inner Carton Dimensions:
370*360*275 mm

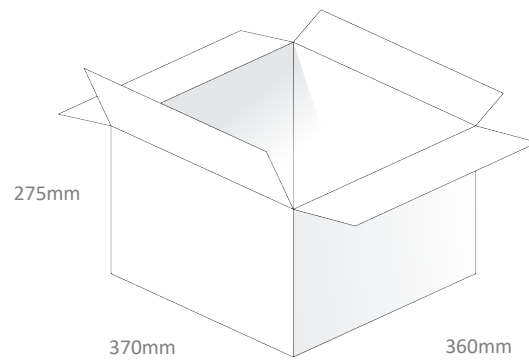

7. Antenna Characteristics

7.1 Return Loss

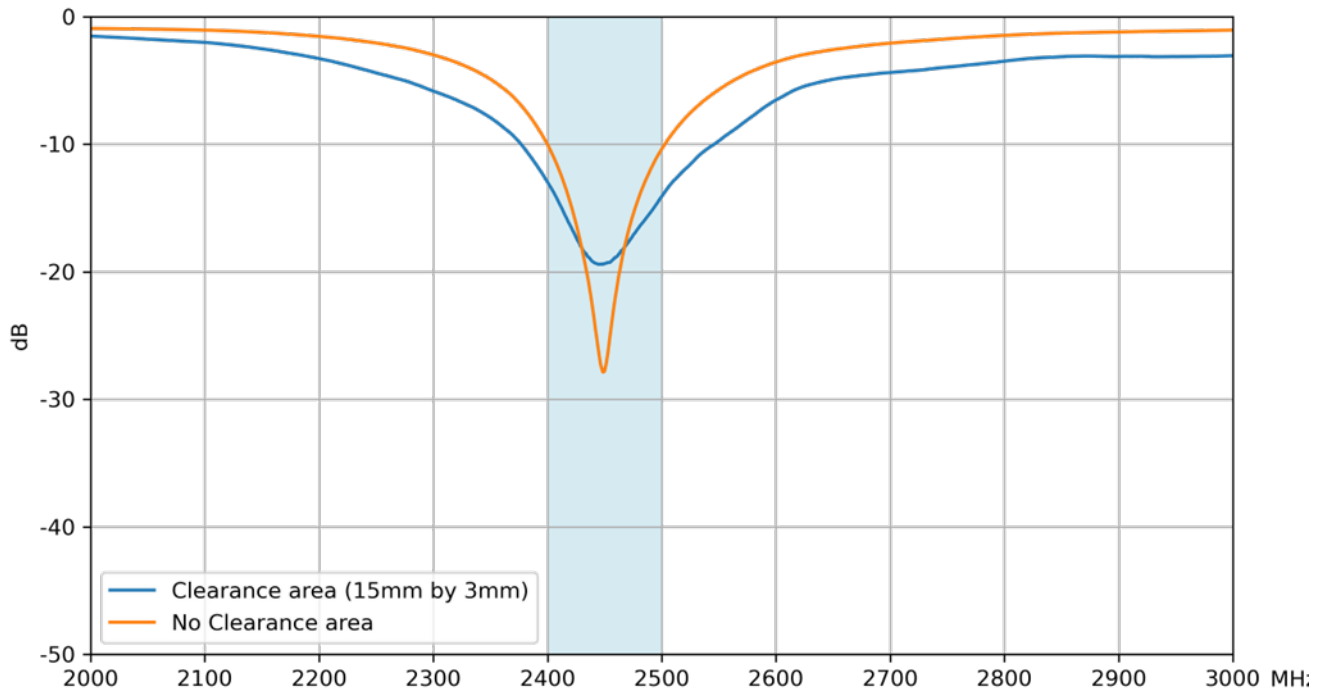

7.2 Efficiency

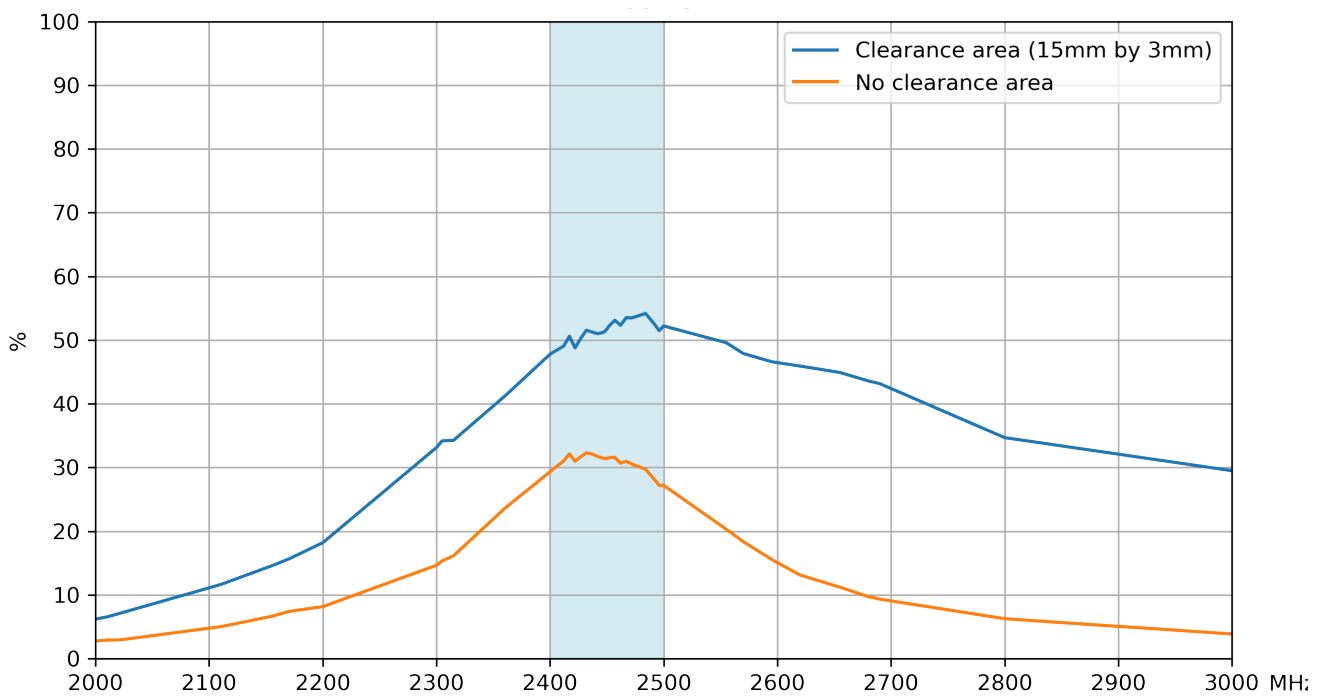

7.3 Average Gain

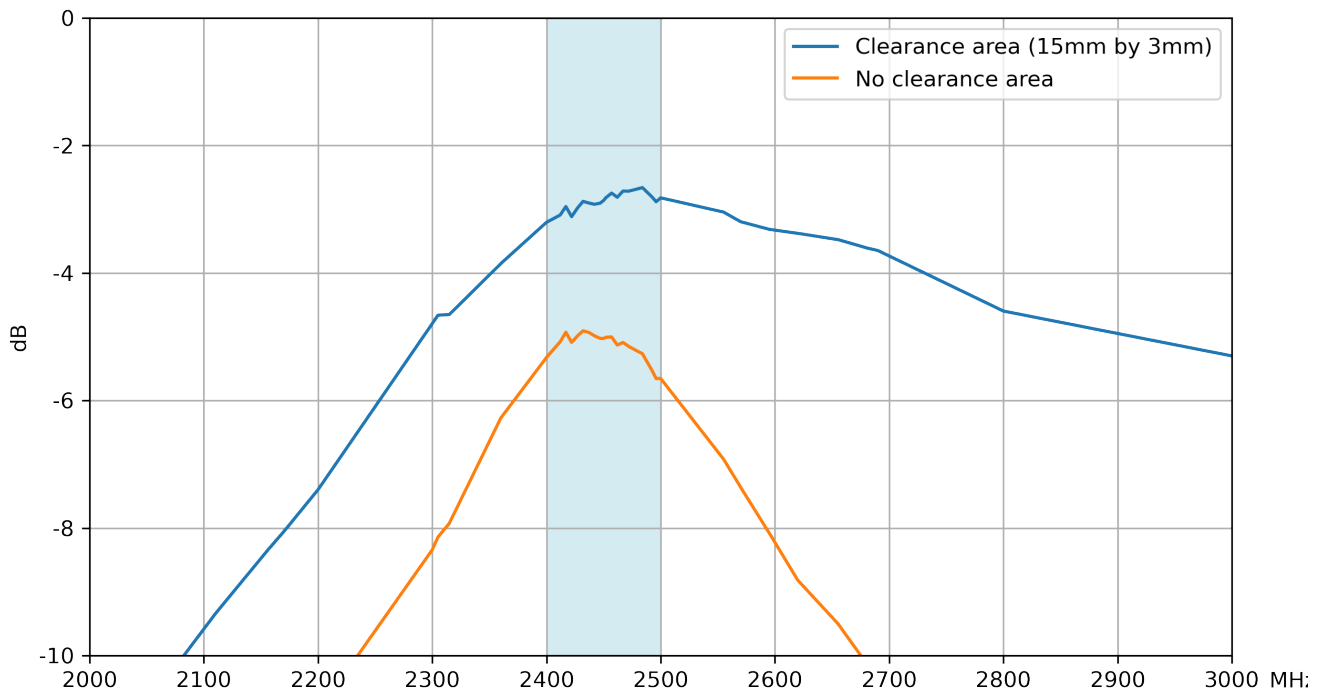

7.4 Peak Gain

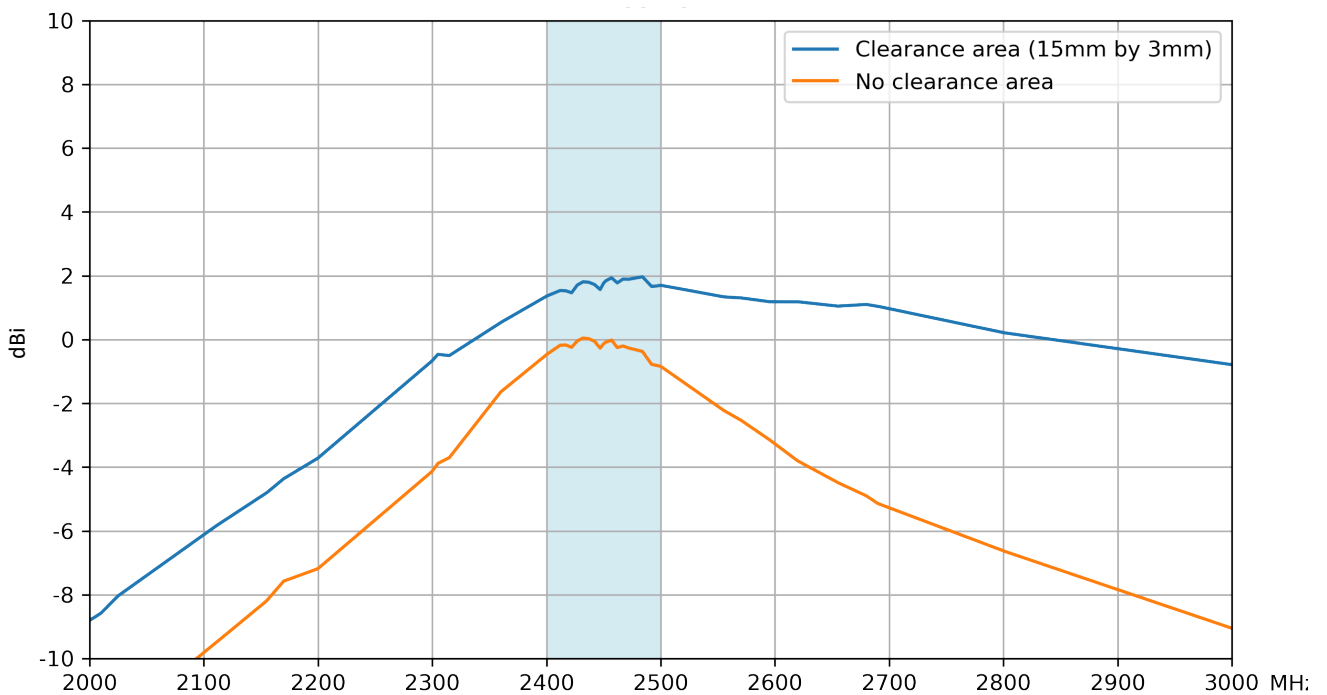

8. Radiation Patterns

8.1 Test Setup

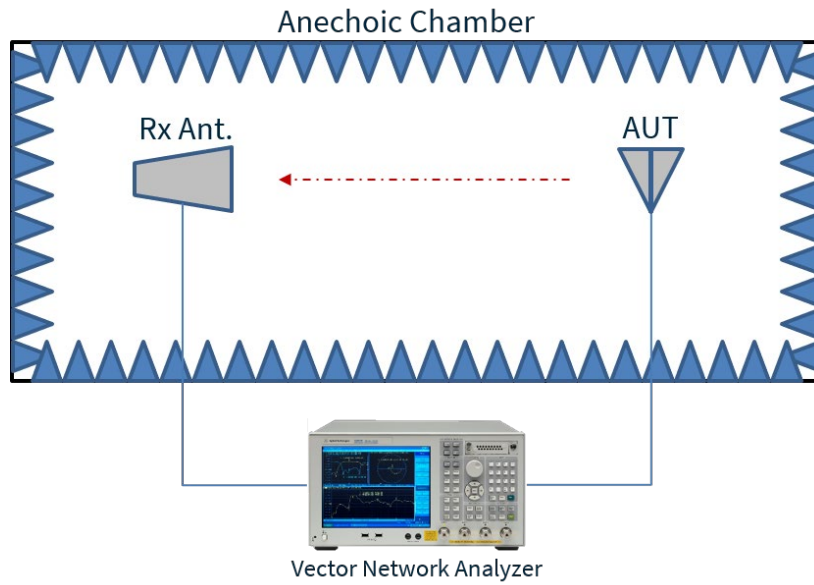

Chamber Test Setup

8.2 Patterns with clearance at 2450MHz

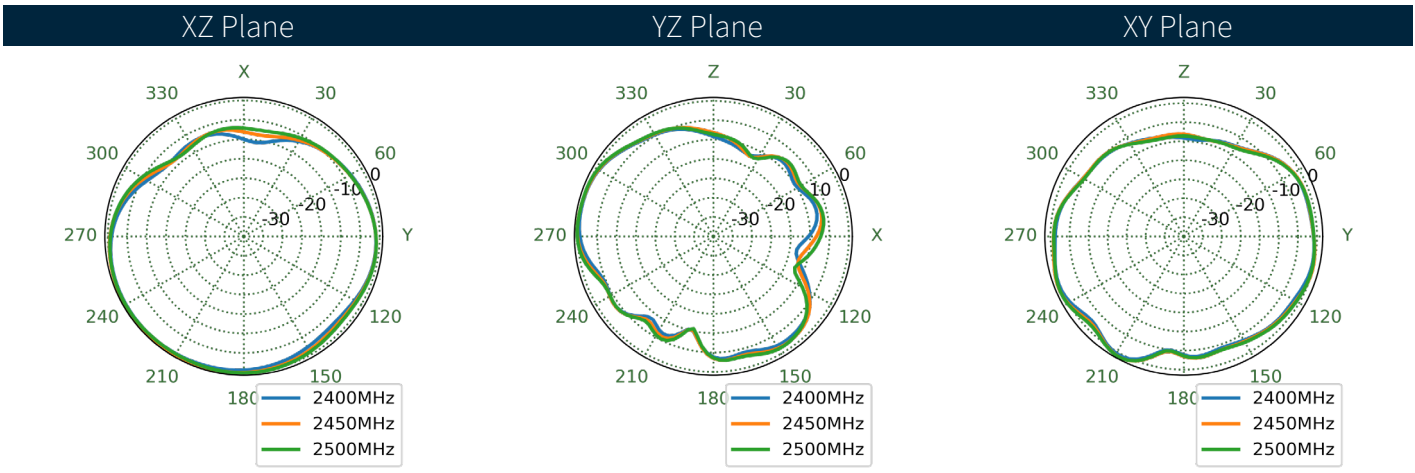
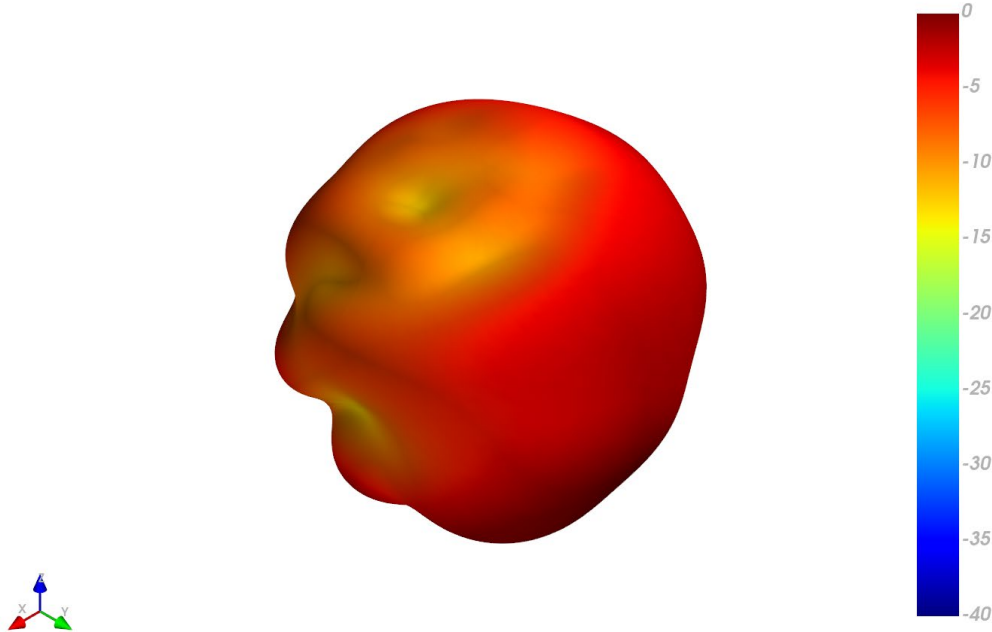

8.3 Patterns with no clearance at 2450MHz

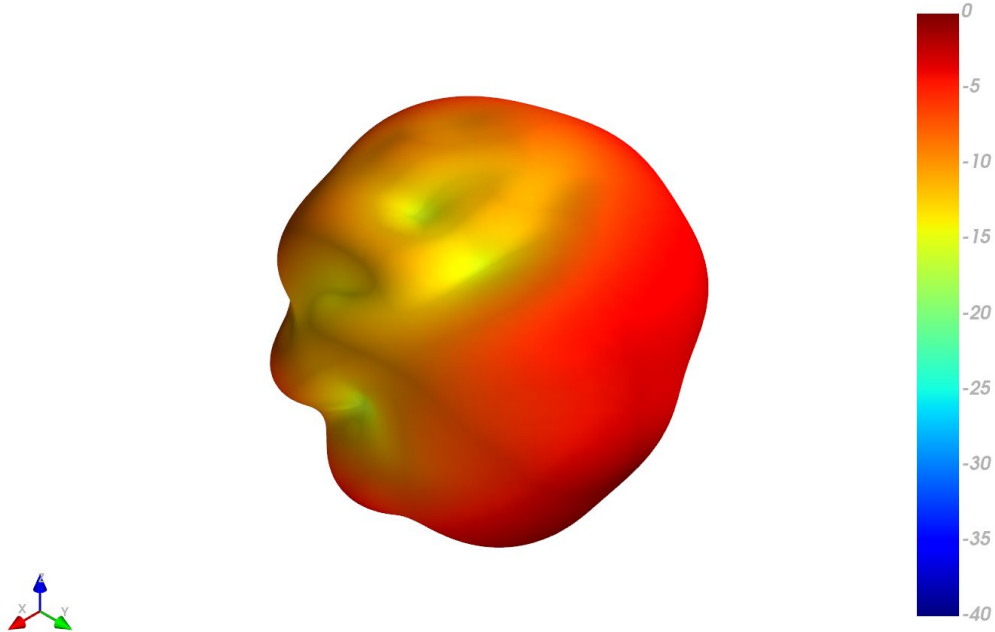

XZ Plane YZ Plane XY Plane

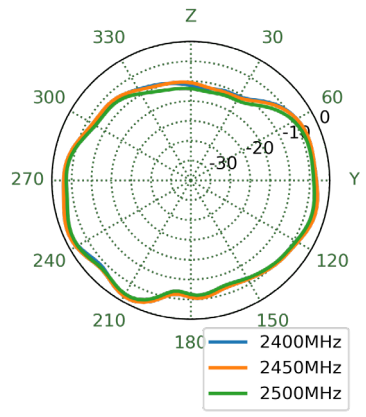
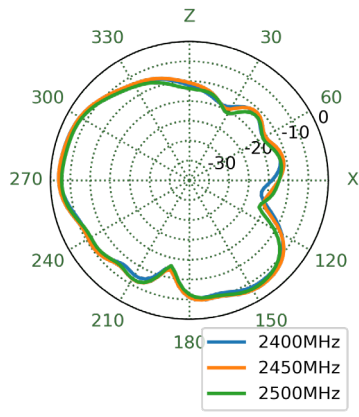
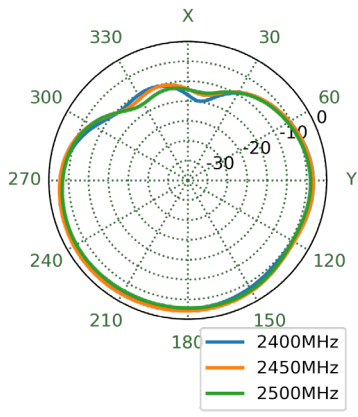

Changelog for the datasheet

SPE-23-8-283– PCS.25.A

Revision: C (Current Version)

Date:	2024-05-28
Notes:	Added moisture sensitivity level information to datasheet.
Author:	Conor McGrath

Previous Revisions

Revision: B

Date:	2024-04-17
Notes:	Updated antenna integration guide and datasheet flow.
Author:	Gary West

Revision: A (Original First Release)

Date:	2023-09-12
Notes:	Initial Release
Author:	Cesar Sousa



www.taoglas.com

