

Features

- RoHS compliant*
- Protects four lines
- Unidirectional and bidirectional configurations
- ESD protection: 30 kV max.

Applications

- Audio/video inputs
- RS-232, RS-422 and RS-423 data lines
- Portable electronics
- Medical sensors

CDNBS08-T03~T36C - TVS Diode Array Series

General Information

The markets of portable communications, computing and video equipment are challenging the semiconductor industry to develop increasingly smaller electronic components.

Bourns offers Steering Diode/Transient Voltage Suppressor Array diodes for surge and ESD protection applications in an eight lead narrow body SOIC package size format. The Transient Voltage Suppressor Array series offer a choice of voltage types ranging from 3 V to 36 V in unidirectional and bidirectional configurations. Bourns® Chip Diodes conform to JEDEC standards, are easy to handle on standard pick and place equipment and their flat configuration minimizes roll away.

The Bourns® device will meet IEC 61000-4-2 (ESD), IEC 61000-4-4 (EFT) and IEC 61000-4-5 (Surge) requirements.

Thermal Characteristics (@ T_A = 25 °C Unless Otherwise Noted)

Parameter	Symbol	Max.	Unit
Operating Temperature	T _J	-55 to +150	°C
Storage Temperature	T _{STG}	-55 to +150	°C

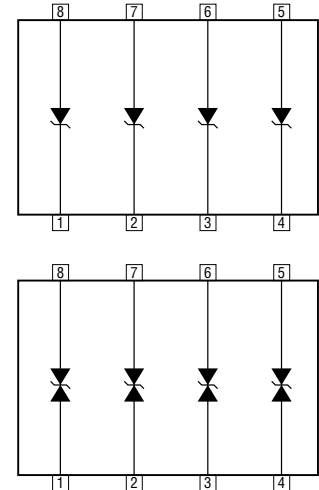

Electrical Characteristics (@ T_A = 25 °C Unless Otherwise Noted)

Parameter	Symbol	CDNBS08-												Unit	
		Uni-T03	Bi-T03C	Uni-T05	Bi-T05C	Uni-T08	Bi-T08C	Uni-T12	Bi-T12C	Uni-T15	Bi-T15C	Uni-T24	Bi-T24C		Uni-T36
Min. Breakdown Voltage @ 1 mA	V _{BR}	3.3		6.0		8.5		13.3		16.7		26.7		40.0	V
Working Peak Voltage	V _{WM}	3.0		5.0		8.0		12.0		15.0		24.0		36.0	V
Max. Clamping Voltage V _C @ I _P = 1 A ¹	V _C	8.0		9.8		13.4		19.0		24.0		43.0		51.0	V
Typ. Clamping Voltage @ 8/20 μs V _C @ I _{PP} ¹	V _C	10.9 V @ 43 A		13.5 V @ 42 A		16.9 V @ 34 A		25.9 V @ 21 A		30.0 V @ 17 A		49.0 V @ 12 A		76.8 V @ 9 A	V
Max. Leakage Current @ V _{WM}	I _D	125		20		10		1		1		1		1	μA
Max. Cap. Bidirectional @ 0 V, 1 MHz	C _{J(SD)}	450		308		300		105		80		50		45	pF
ESD Protection per IEC 61000-4-2 Contact - Min. Contact - Max. Air - Min. Air - Max.	ESD													±8 ±30 ±15 ±30	kV
Peak Pulse Power (t _p = 8/20 μs) ²	P _{PP}													500	W
Forward Voltage @ 100 mA, 300 μs - Square Wave ³	V _F													1.5	V

Notes:

1. See Pulse Wave Form.
2. See Peak Pulse Power vs. Pulse Time.
3. Only applies to unidirectional devices.
4. Part numbers with a "C" suffix are bidirectional devices, i.e. CDNBS08-T03C.

*RoHS Directive 2002/95/EC Jan. 27, 2003 including annex and RoHS Recast 2011/65/EU June 8, 2011.
Specifications are subject to change without notice.

Customers should verify actual device performance in their specific applications.

CDNBS08-T03~T36C - TVS Diode Array Series



Product Dimensions

This is an RoHS compliant molded JEDEC narrow body SO-8 package with 100 % Sn plating on the lead frame. It weighs approximately 15 mg and has a flammability rating of UL 94V-0.

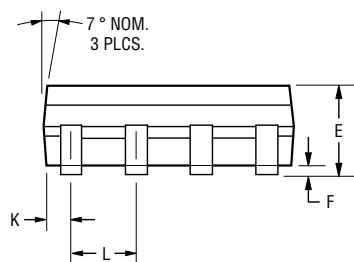
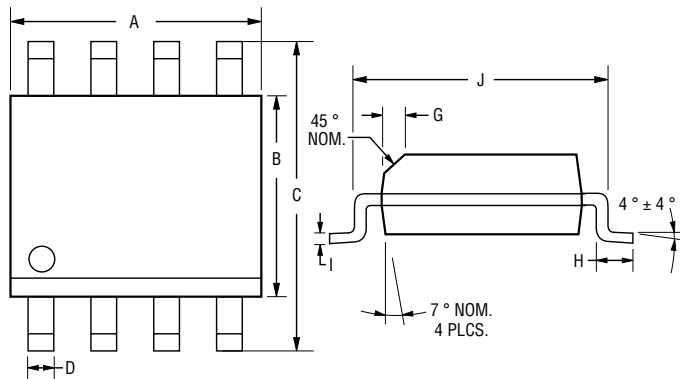

DIMENSIONS = $\frac{\text{MILLIMETERS}}{\text{(INCHES)}}$

Dimensions	
A	$\frac{4.80 - 5.00}{(0.189 - 0.197)}$
B	$\frac{3.81 - 4.00}{(0.150 - 0.157)}$
C	$\frac{5.80 - 6.20}{(0.228 \pm 0.244)}$
D	$\frac{0.36 - 0.51}{(0.014 - 0.020)}$
E	$\frac{1.35 - 1.75}{(0.053 - 0.069)}$
F	$\frac{0.102 - 0.203}{(0.004 - 0.008)}$
G	$\frac{0.25 - 0.50}{(0.010 - 0.020)}$
H	$\frac{0.51 - 1.12}{(0.020 - 0.044)}$
I	$\frac{0.190 - 0.229}{(0.0075 - 0.0090)}$
J	$\frac{4.60 - 5.21}{(0.181 - 0.205)}$
K	$\frac{0.28 - 0.79}{(0.011 - 0.031)}$
L	$\frac{1.27}{(0.050)}$

Recommended Footprint

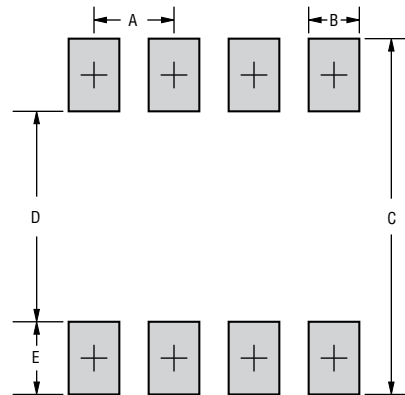

Dimensions	
A	$\frac{1.143 - 1.397}{(0.045 - 0.065)}$
B	$\frac{0.635 - 0.889}{(0.025 - 0.035)}$
C	$\frac{6.223}{(0.245)}$ Min.
D	$\frac{3.937 - 4.191}{(0.155 - 0.165)}$
E	$\frac{1.016 - 1.27}{(0.040 - 0.050)}$

Typical Part Marking

CDNBS08-T03.....SDL	CDNBS08-T12C.....SDD
CDNBS08-T03C.....SDM	CDNBS08-T15.....SDE
CDNBS08-T05.....SDA	CDNBS08-T15C.....SDF
CDNBS08-T05C.....SDB	CDNBS08-T24.....SDG
CDNBS08-T08.....SDJ	CDNBS08-T24C.....SDH
CDNBS08-T08C.....SDK	CDNBS08-T36.....SDN
CDNBS08-T12.....SDC	CDNBS08-T36C.....SDP

How to Order

Common Code	CD NBS08 - T 03 C
Chip Diode	
Package	NBS08 = Narrow Body SOIC8 Package
Model	T = Transient Voltage Suppressor
Working Peak Voltage	03 = 3 V _{RWM} (Volts)
Suffix	C = Bidirectional Diode

Specifications are subject to change without notice. Customers should verify actual device performance in their specific applications.

CDNBS08-T03~T36C - TVS Diode Array Series

Performance Graphs

Peak Pulse Power vs Pulse Time

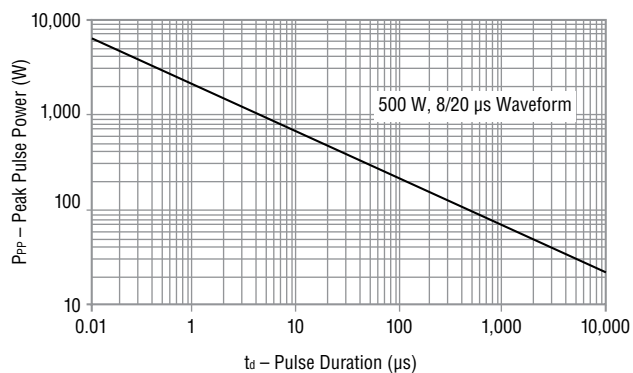

Pulse Waveform

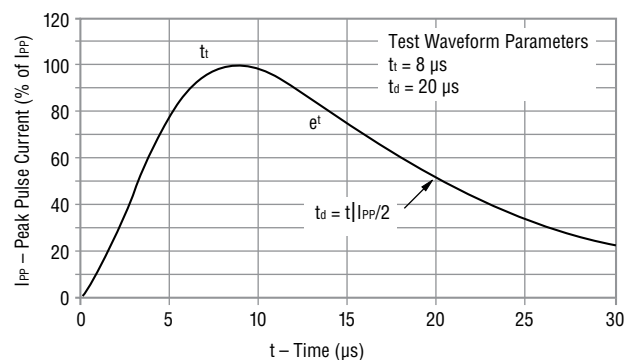

Block Diagram

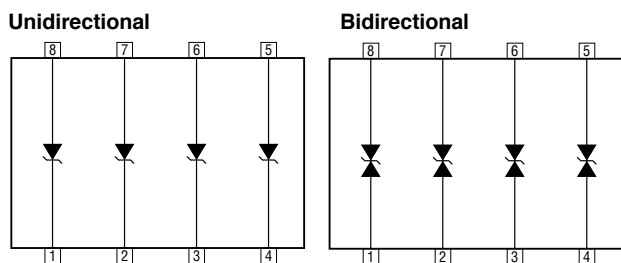

Power Derating Curve

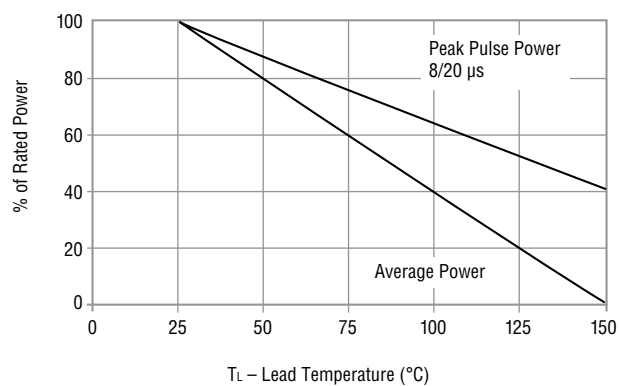

Device Pinout

Pin	Function
1	I/O 1
2	I/O 2
3	I/O 3
4	I/O 4
5	GND
6	GND
7	GND
8	GND

Specifications are subject to change without notice.
Customers should verify actual device performance in their specific applications.

CDNBS08-T03~T36C - TVS Diode Array Series

BOURNS®

Packaging Information

The product is packaged in tape and reel format per EIA-481 standard.

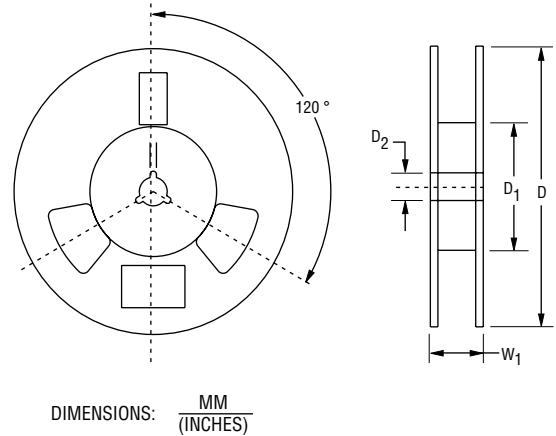
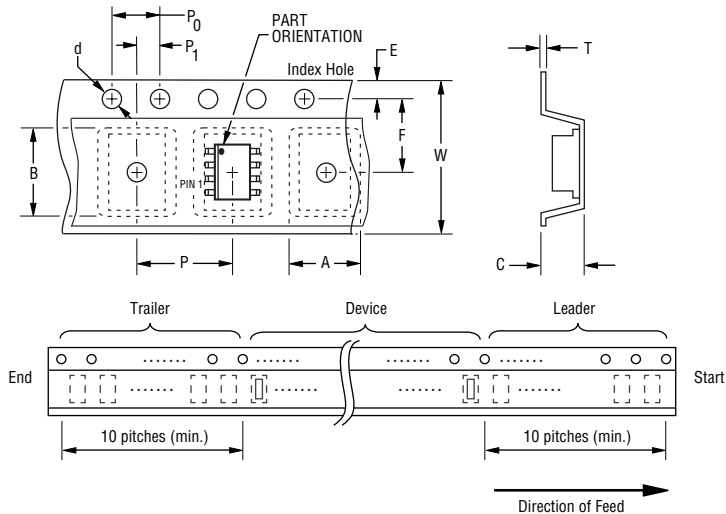

Item	Symbol	NSOIC 8L
Carrier Width	A	$\frac{6.7 \pm 0.10}{(0.264 \pm 0.004)}$
Carrier Length	B	$\frac{5.5 \pm 0.10}{(0.217 \pm 0.004)}$
Carrier Depth	C	$\frac{2.10 \pm 0.10}{(0.083 \pm 0.004)}$
Sprocket Hole	d	$\frac{1.55 \pm 0.05}{(0.061 \pm 0.002)}$
Reel Outside Diameter	D	$\frac{330}{(12.992)}$
Reel Inner Diameter	D ₁	$\frac{80.0}{(3.1500)}$ MIN.
Feed Hole Diameter	D ₂	$\frac{13.0 \pm 0.20}{(0.512 \pm 0.008)}$
Sprocket Hole Position	E	$\frac{1.75 \pm 0.10}{(0.069 \pm 0.004)}$
Punch Hole Position	F	$\frac{3.50 \pm 0.05}{(0.138 \pm 0.002)}$
Punch Hole Pitch	P	$\frac{8.00 \pm 0.10}{(0.315 \pm 0.004)}$
Sprocket Hole Pitch	P ₀	$\frac{4.00 \pm 0.10}{(0.157 \pm 0.004)}$
Embossment Center	P ₁	$\frac{2.00 \pm 0.05}{(0.079 \pm 0.002)}$
Overall Tape Thickness	T	$\frac{0.20 \pm 0.10}{(0.008 \pm 0.004)}$
Tape Width	W	$\frac{12.00 \pm 0.20}{(0.472 \pm 0.008)}$
Reel Width	W ₁	$\frac{18.4}{(0.724)}$ MAX.
Quantity per Reel	--	2500

BOURNS®

Asia-Pacific:

Tel: +886-2 2562-4117

Email: asiacus@bourns.com

Europe:

Tel: +36 88 520 390

Email: eurocus@bourns.com

The Americas:

Tel: +1-951 781-5500

Email: americus@bourns.com

www.bourns.com

REV. 05/17

Specifications are subject to change without notice.
Customers should verify actual device performance in their specific applications.