

TAP800 Series

800 Watt Heat Sinkable Planar

FEATURES

- Electric support is high alumina content ceramic metallized on the bottom for ideal heat transfer and optimum discharge.
- Encapsulated with a special resin filled epoxy casing with a large creepage distance to mass, large air distance between terminals, and a high insulation resistance (CTI 600).
- Resistive element is specially designed for low inductance and capacitance. The element provides stable performance in addition to high wattage and pulse loading capability.
- Contacts allow for easy load connecting with M4 or M5 screws (not included).
- Materials meet the requirements of UL94-V0



Ohmite's TAP800 Series dissipates 800 watts of power when used with a liquid or air cooled heat sink system. The Ohmite CP4 (<https://www.ohmite.com/cp4-series-chillplate/>) is an example of properly designed heat sink. The TAP800 compliments the 600 watt (TAP600), 650 watt (TAP650) and 2000 watt (TAP2000) product offerings. Applications include variable speed drives, power supplies, robotics, motor control, control devices, and other power designs.

CHARACTERISTICS

Resistance Values	1Ω to 10KΩ
Resistance Tolerance	±5% to ±10%
Temperature Coefficient	±150ppm/°C (others upon request)
Maximum Working Voltage	5,000V DC, higher voltage on request, not exceeding max. power
Short Time Overload	1,200W at 70°C for 10sec., ΔR=0.4% max.
Power Rating	800W at 85°C Bottom case temperature.
Peak Current	up to 1500 amp. depending on pulse length and frequency Please ask for details
Electric Strength Voltage	7K Vrms, 50Hz, up to 12K Vrms on special request
Single Shot Voltage	up to 12kV Normwave (1.5/50 μsec)
Partial Discharge	4KVrms, <10pC, up to 7kV on special request
Insulation Resistance	10GΩ min. at 500V
Creeping Distance	42mm min.
Air Distance	14mm min.
Inductance	80nH
Capacity/Mass	110pF
Capacity/Parallel	40pF
Operation Temperature	-55°C to +150°C
Max. Torque for Contacts	2 Nm
Max. Torque for Mounting	1.8 Nm M4 screws (not included)
Derating	9.09W/°K (0.11°K/W)
Power Rating	800W at 85°C bottom case temp. This value is only valid by using a thermal conduction to the heatsink Rth-cs<0.025°K/W. This value can be reached by using thermal transfer compound with a heat conductivity of 1W/mK. The flatness of the cooling plate must be better than 0.05mm overall. The roughness of the surface should not exceed 6.4μm.

Test	Method	Typical Results ΔR
Short time overload	1,000 W/10sec	0.4%
Humidity Steady State	56 days/40°C/95%	0.25%
Temp. Cycling	-55/+125/5 cycles	0.20%
Shock	40g/4,000 times	0.25%
Vibration	2-500Hz/10g	0.25%
Load Life	Pn 30 min. on/30 min off, 1,000cyl	0.40%
Terminal Strength	200N	0.05%

Derating

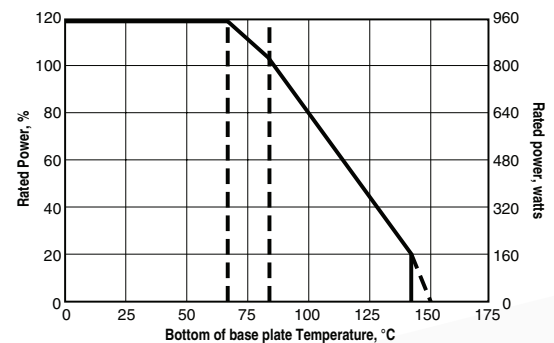

(continued)

TAP800 Series

800 Watt Heat Sinkable Planar

PULSE ENERGY AND POWER CURVES

Typical rating for TAP800 with 2R and 10% tolerance

These energy values are reference values; depending on ohmic value and used resistive paste, a variation in max. energy load capability is possible. The power curve shows the max. possible power which can be applied for a certain duration.

- Mounted with thermal compound (0.9 W/mK) on a water-cooled heatsink
- Constant inlet water temp.: +50°C
- Test time: 10 min.
- Break time between pulses: 1sec.
- Change in ohm value: $\leq 0.1\%$
- Pulse shape: e-function
- Time between two pulses: 1 sec.
- Pulse length: time constant of 1 tau (1 means ... tau = 1ms)

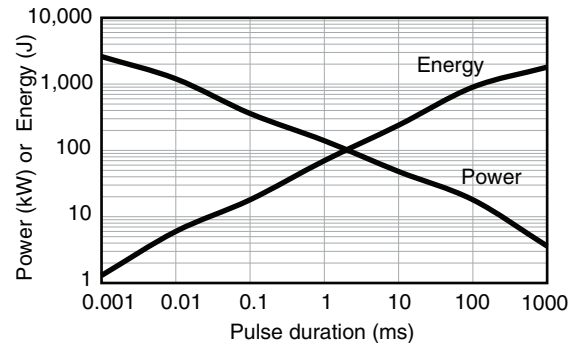

Examples

Energy: At 1ms tau the TAP800 with 2R can stand an energy level of about 70J when the pulse pause time is $\geq 1s$

At a symmetrical frequency $> 1kHz$ at pulse length $\geq 10 \mu sec.$, the maximum appulse energy is a result of the nominal power 800W divided by the operating frequency (at 85°C bottom case) ($E=800W/F$)

Power: For the time-constant of 1ms you can apply about 140kW max. ($P_p = 2 * E/T$)—when the time between two such peaks is $\geq 1s$

DIMENSIONS

(mm/in.)

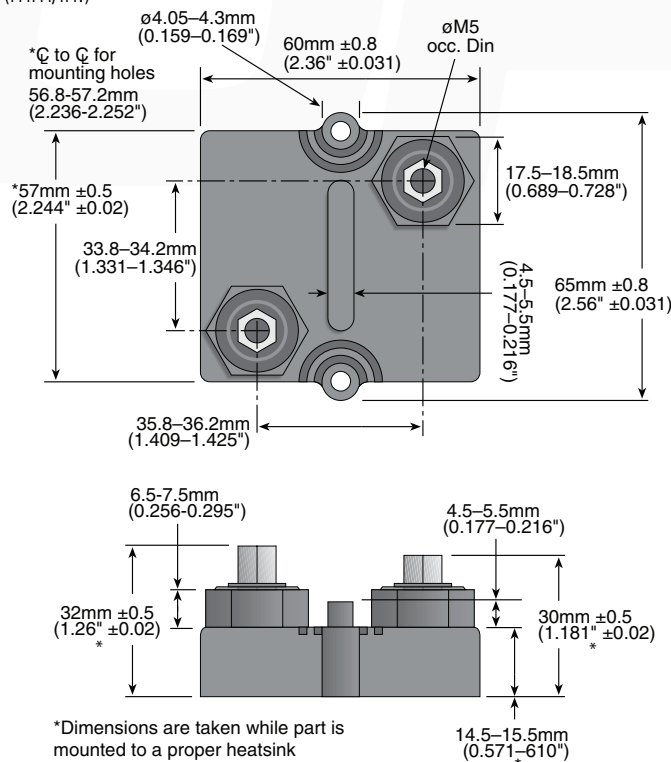

ORDERING INFORMATION

RoHS compliant
Non-compliant version
unavailable

TAP 800 K 5 R 0 E

Style	Wattage	Tolerance	Resistance
	800 watts	J = 5% K = 10%, Std. L = 20%	1 Ohm = 1R 10 Ohm = 10R 1000 Ohm = 1K0

Standard Values

10% tol.

TAP800K25E
TAP800K33E
TAP800K50E
TAP800K75E
TAP800K10E
TAP800K100E
TAP800K220E
TAP800K7R5E
TAP800K10RE
TAP800K15RE

TAP800K25RE
TAP800K50RE
TAP800K75RE
TAP800K100E
TAP800K220E
TAP800K300E
TAP800K390E

TAP800K680E
TAP800K750E
TAP800K1K0E
TAP800K2K7E
TAP800K5K0E
TAP800K7K5E
TAP800K10KE

5% tol.

TAP800J1R0E
TAP800J10RE
TAP800J50RE
TAP800J100E
TAP800J500E
TAP800J1K0E