

SPECIFICATION CONTROL DRAWING

55A8595

| | | | | | |
|-------|--|------|---------|----------|---|
| TITLE | WIRE, RADIATION-CROSSLINKED, MODIFIED ETFE-INSULATED, NORMAL WEIGHT, GENERAL PURPOSE, 600 VOLT | Date | 1-28-08 | Revision | H |
|-------|--|------|---------|----------|---|

This specification sheet forms a part of the latest issue of Raychem Specification 55A.

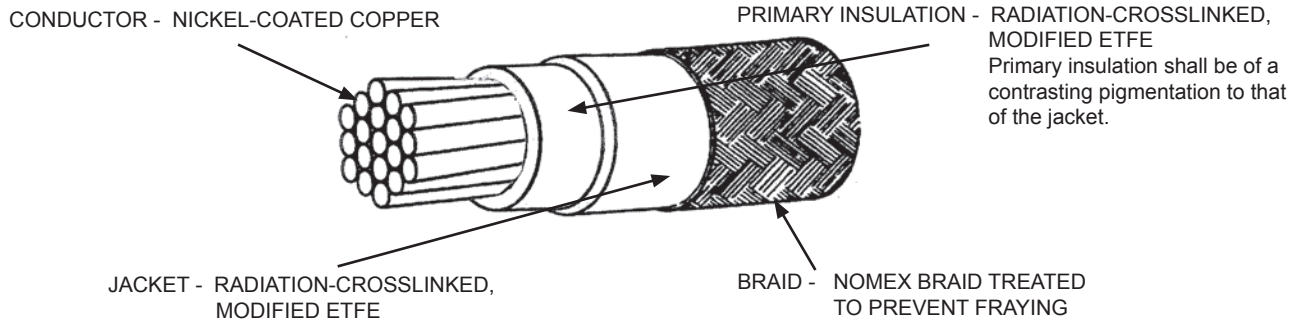

TABLE I. CONSTRUCTION DETAILS

| PART NUMBER 1/ | WIRE SIZE (AWG) | CONDUCTOR STRANDING (number x AWG) | DIAMETER OF STRANDED CONDUCTOR (in.) | | FINISHED WIRE | | |
|-------------------|--------------------|---------------------------------------|---|---------|--|-------------------|----------------------------------|
| | | | MINIMUM | MAXIMUM | MAXIMUM RESISTANCE AT 20°C (ohms/1000 ft.) | DIAMETER (in.) | MAXIMUM WEIGHT (lbs/1000 ft.) |
| | | | | | | | |
| 55A8595- 2-* | 2 | 665 x 30 | .320 | .340 | .177 | .405 ± .016 | 246. |
| 55A8595- 1-* | 1 | 817 x 30 | .360 | .380 | .144 | .445 ± .016 | 314. |
| 55A8595- 0-* | 0 | 1045 x 30 | .395 | .425 | .113 | .485 ± .016 | 421. |
| 55A8595-00-* | 00 | 1330 x 30 | .440 | .475 | .089 | .545 ± .016 | 518. |
| 55A8595-000-* | 000 | 1665 x 30 | .500 | .540 | .071 | .625 ± .022 | 625. |
| 55A8595-0000-* | 0000 | 2109 x 30 | .565 | .605 | .056 | .690 ± .022 | 773. |

TABLE II. PERFORMANCE DETAILS

| PART NUMBER 1/ | BEND TESTING | | | |
|-------------------|---|--------------|---|--------------|
| | MANDREL DIAMETER (inch) (± 3%) | | WEIGHT (lb) (± 3%) | |
| | IMMERSION, LIFE CYCLE AND ACCELERATED AGING | COLD BEND | IMMERSION, LIFE CYCLE AND ACCELERATED AGING | COLD BEND |
| | | | | |
| 55A8595- 2-* | 6.00 | 8.00 | 6.00 | 15.0 |
| 55A8595- 1-* | 8.00 | 10.0 | 6.00 | 15.0 |
| 55A8595- 0-* | 8.00 | 10.0 | 6.00 | 15.0 |
| 55A8595-00-* | 10.0 | 12.0 | 8.00 | 20.0 |
| 55A8595-000-* | 10.0 | 12.0 | 8.00 | 20.0 |
| 55A8595-0000-* | 10.0 | 12.0 | 8.00 | 20.0 |

Users should evaluate the suitability of this product for their application. Specifications are subject to change without notice. Tyco Electronics also reserves the right to make changes in materials or processing, which do not affect compliance with any specification, without notification to Buyer.

1/ COLORS AND COLOR CODE DESIGNATORS SHALL BE IN ACCORDANCE WITH MIL-STD-681. OTHER CODES AND SUFFIXES MAY BE ADDED TO THE PART NUMBER. AS NECESSARY, TO CAPTURE ANY ADDITIONAL REQUIREMENTS IMPOSED BY THE PURCHASE ORDER.

| | | | |
|-------------|--|--|--|
| Page 1 of 2 | The TE logo, Tyco Electronics and Raychem are trademarks. NOMEX is a registered trademark of E.I. du Pont de Nemours and Company | | Raychem Wire & Cable 501 Oaks Avenue Redwood City, CA 94063-3800 Phone: 1-800-227-8816 Fax: 1-650-361-6297 |
| | DIMENSIONS ARE IN INCHES, AND UNLESS OTHERWISE DESIGNATED ARE NOMINAL. | | |
| | THIS SPECIFICATION SHEET TAKES PRECEDENCE OVER DOCUMENTS REFERENCED HEREIN. REFERENCED DOCUMENTS SHALL BE OF THE ISSUE IN EFFECT ON DATE OF INVITATION FOR BID. | | |

WIRE RATINGS AND ADDITIONAL REQUIREMENTS

TEMPERATURE RATING: 200°C

Maximum continuous conductor temperature

VOLTAGE RATING: 600 volts (rms), at sea level

ACCELERATED AGING (CROSSLINKING PROOF): 300 ± 3°C for 7 hours

BLOCKING: 230 ± 3°C for 24 hours

BRAID COLOR: Dark green preferred; munsell color limits 5Y 3/2 and 5B 2/0.5

CONCENTRICITY: 70% (minimum)

FLAMMABILITY: Procedure 1, 3 seconds (maximum); 3 inches (maximum); no flaming of facial tissue

HUMIDITY RESISTANCE: Insulation Resistance, 3000 megohms for 1000 ft. (minimum)

IMMERSION: Diameter increase 5% (maximum); no cracking, no dielectric breakdown

INSULATION ELONGATION AND TENSILE STRENGTH:

Tensile strength, 5000 lbf/in² (minimum) for primary insulation

5000 lbf/in² (minimum) for total insulation (primary insulation and jacket)

Elongation, 75% (minimum) for total insulation (primary insulation and jacket)

INSULATION FLAWS:

Primary Insulation,

Spark Test, 1.5 kV (rms) at 60 Hz

4.2 kV (rms) at 3 kHz

Impulse Dielectric Test, 6.0 kV (peak)

Finished Wire,

Spark Test, 5.7 kV (rms) at 3 kHz

Impulse Dielectric Test, 8.0 kV (peak)

INSULATION RESISTANCE: 3000 megohms for 1000 ft. (minimum)

INSULATION THICKNESS: 0.003 in. (minimum) for primary insulation,

0.004 in. (minimum) for outer jacket

0.009 in. (minimum) for total insulation

LIFE CYCLE: 230 ± 3°C for 500 hours

LOW TEMPERATURE-COLD BEND: -65 ± 3°C for 4 hours

SHRINKAGE: 230 ± 3°C, for 6 hours, 0.125 in. (maximum) in 12 inches

SMOKE TEST: 250 ± 5°C, no visible smoke

SURFACE RESISTANCE: 500 megohms-in. (minimum), both readings

THERMAL SHOCK RESISTANCE: 200 ± 3°C, 0.125 in. (maximum)

VOLTAGE WITHSTAND TEST (Post Environmental): 2500 volts (rms), 60 Hz

WICKING: 2.25 in. (maximum)

WRAP TEST: 313 ± 3°C for 2 hours

PART NUMBER:

The "*" in the part numbers on page 1 shall be replaced by a color code designator.

5D shall be used to designate dark green.

^{1/} Example: AWG 2, dark green; 55A8595-2-5D

AWG 2, white; 55A8595-2-9

^{1/} See footer section on page 1