

PRODUCT DATA DRAWING

REVISION HISTORY			
REV	DESCRIPTION	DATE	APPROVED
B	DCN 55255	09/24	SEE PDM

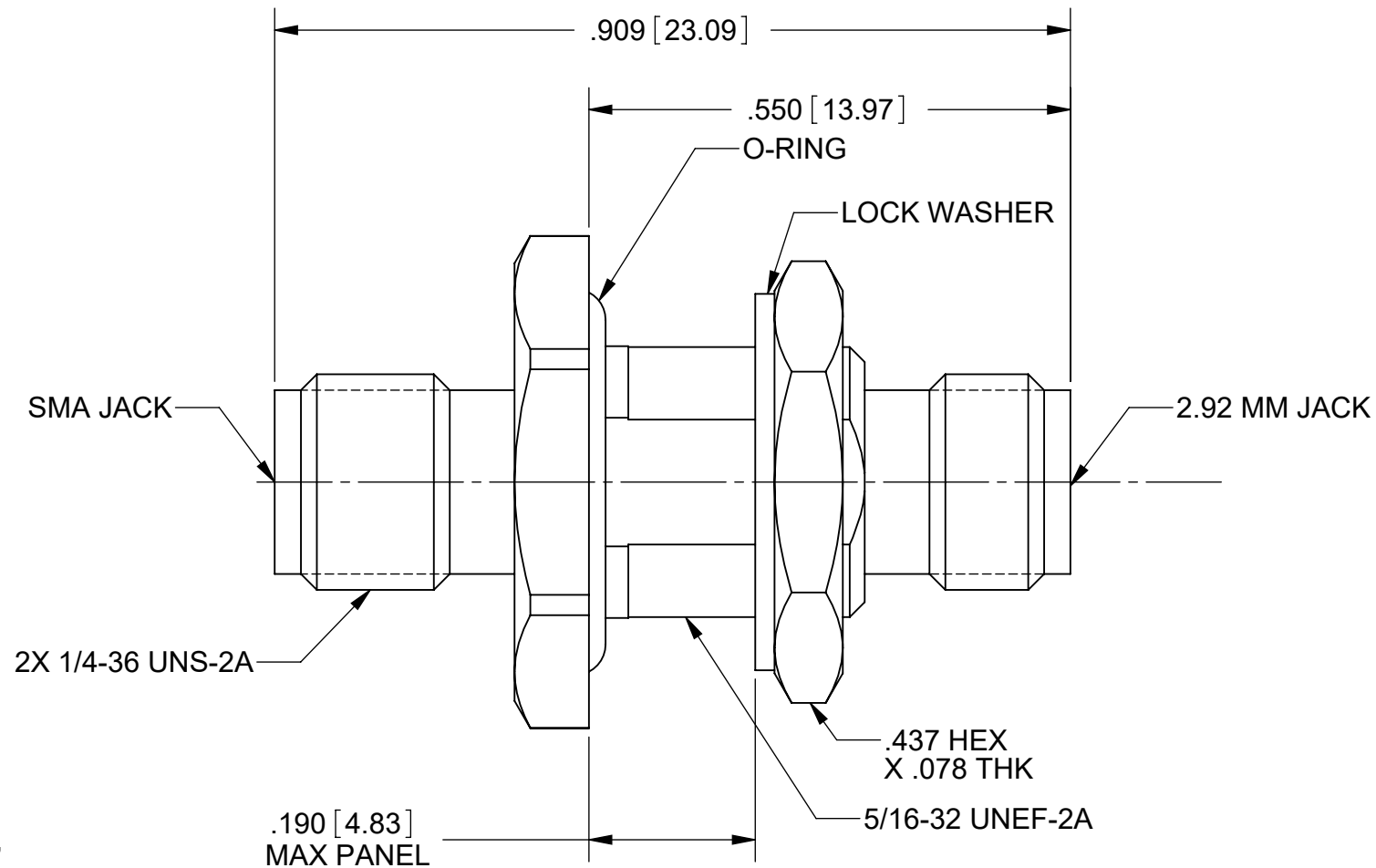
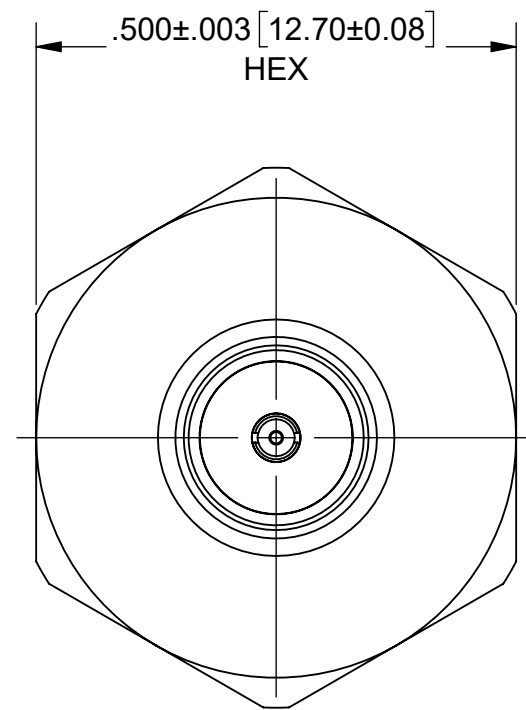

MATERIAL:

BODY, HEX NUT, & INSERT:

STAINLESS STEEL PER AMS-5640, ALLOY UNS S30300, TYPE 1

LOCKWASHER:

400 SERIES STAINLESS STEEL

CONTACTS:

BERYLLIUM COPPER PER ASTM B196, ALLOY No. UNS C17300, TD04

CENTER PIN:

KOVAR PER ASTM F15

GLASS BEAD:

CORNING #7070, OR EQUIVALENT .

BEAD:

POLYETHERMIDE RESIN (ULTEM) PER ASTM D5205

INSULATOR:

PTFE PER ASTM D1710, TYPE 1, GRADE 1, CLASS B

O-RING:

SILCONE RUBBER

FINISH:

BODY, HEX NUT, INSERT & LOCK WASHER:

PASSIVATED PER AMS-2700

CONTACT:

GOLD PER ASTM B488, TYPE II, CODE C, CLASS 1.27; OVER NICKEL PER AMS-QQ-N-290, CLASS 1, .00005" MIN.

PERFORMANCE:

IMPEDANCE:
FREQ. RANGE:

50 OHMS
DC TO 18.0 GHz

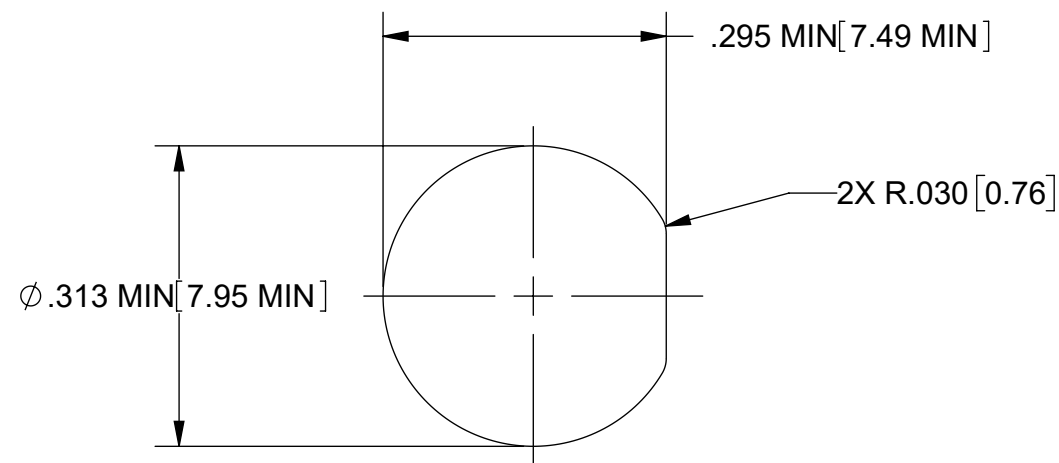

RECOMMENDED MOUNTING HOLE

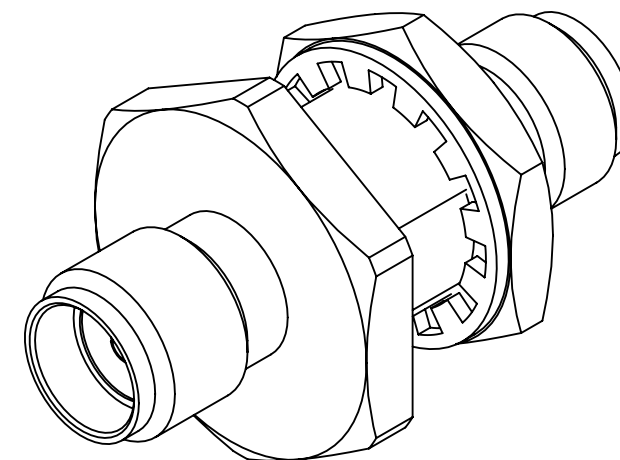

MATERIAL:	SEE NOTES	DIMENSIONS ARE IN INCHES TOLERANCES:	UNLESS OTHERWISE SPECIFIED 1) ALL DIMENSIONS ARE IN INCHES (MILLIMETERS) 2) ALL DIMENSIONS ARE AFTER PLATING. 3) BREAK CORNERS & EDGES .005 R. MAX. 4) CHAM. 1ST & LAST THREADS. 5) SURFACE ROUGHNESS 63-MIL-STD-10. 6) DIA: 'S ON COMMON CENTERS TO BE CONCENTRIC WITHIN .005 T.I.R. 7) REMOVE ALL BURRS	 www.svmicrowave.com TITLE: STR. F SMA TO STR. F 2.92mm HERMETIC BLKHD ADAPTER
FINISH:	SEE NOTES	FRACTIONAL: ±1/64 ANGULAR: X° ±1'0" X°X' ±15"		
SURFACE AREA:	N/A	DECIMAL: X ±.030 .XX ±.010 .XXX ±.005	INTERPRET DIMENSIONS AND TOLERANCES PER ASME Y14.5M - 1994	DRAWN: JPM 09/16/22 CHECKED: SEE PDM APPROVED: SEE PDM
PROPRIETARY THE INFORMATION CONTAINED IN THIS DRAWING IS THE SOLE PROPERTY OF SV MICROWAVE, INC. ANY REPRODUCTION IN PART OR AS A WHOLE WITHOUT THE WRITTEN PERMISSION OF SV MICROWAVE, INC IS PROHIBITED.		THIRD ANGLE PROJECTION 		SIZE DWG. NO. B 1115-6141 SCALE: 5:1 SHEET 1 OF 1