

APPROVED: _____
 DATE: _____ TITLE: _____

Rev	AWO #	Description	Date	Appr
-		RELEASED	8/16/17	
A		UPDATED DRAWING	1/15/19	HR/YC

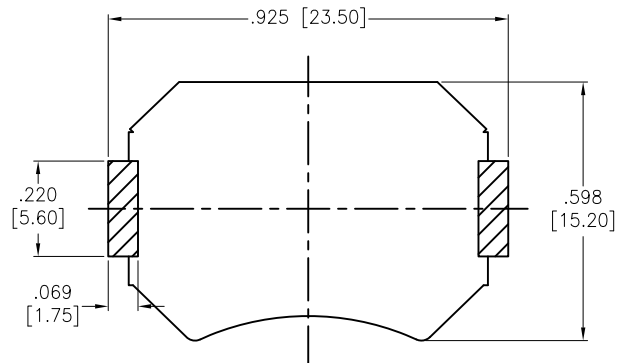

RECOMMENDED PCB LAYOUT

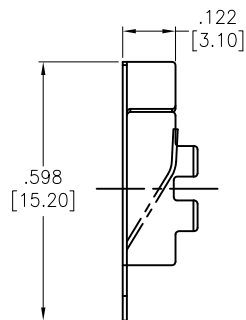
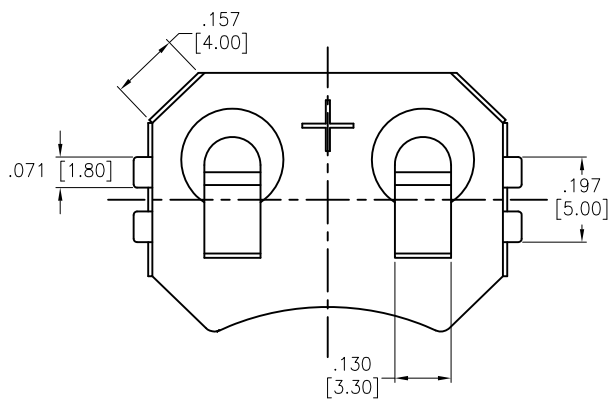
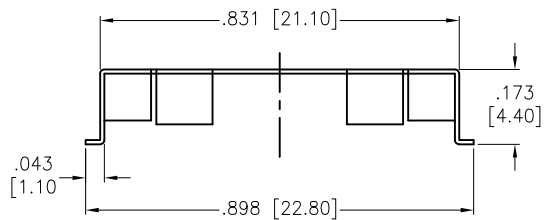

PACKAGED ON TAPE & REEL

UNLESS OTHERWISE SPECIFIED ALL DIMENSIONS ARE INCHES [MM] TOLERANCES: EXCEPT AS NOTED INCHES HOLES .X ± .10 Ø.X ± .10 .XX ± .020 Ø.XX ± .015 .XXX ± .015 Ø.XXX ± .010		ADAM TECH INTERCONNECTS		909 Rahway Avenue, Union, NJ 07083 Phone: 908-687-5000 Fax: 908-687-5710	
APPROVALS			DATE		
DRAWN	HR	8/16/17			
CHECKED	RT	8/16/17			
APPROVED					
TITLE BATTERY CLIP, CR 2032, TAPE & REEL					
SIZE	PART NO.	REV.			
X	BH-67B-5-T/R	A			
REF:	S00136C	SCALE:	NTS	SHEET 1 OF 1	

SPECIFICATIONS:
 Material: T=0.25mm Phosphor Bronze , Nickel plated.
 Environmental:
 Lead free, RoHS compliant

